

# *Instruction Manual*



**SPDE CXP**  
No Till Seed Drill Special

 **BALDAN**



## INTRODUCTION

**W**e appreciate your purchase and congratulate you for the excellent choice you just made because you have purchased a product manufactured with technology from **BALDAN IMPLEMENTOS AGRÍCOLAS S/A.**

This instruction manual will guide you through the procedures that are necessary since its acquisition up to the operating procedures of use, security and maintenance.

**BALDAN** ensures that has delivered this farming implement to the dealer in perfect conditions.

The dealer is responsible for the custody and maintenance of this farming implement and also for the assemblage, retightening, lubrication and overhaul.

In the technical delivery, the dealer must advise the user on its maintenance, security, its obligations under any technical assistance, the strict observance of the guarantee and reading of the instruction manual.

Any request for technical assistance under warranty should be made to the dealer where it was purchased.

We reiterate the need for careful reading of the Warranty Certificate and observance of all items in this instruction manual, as doing so, the useful life of your farming implement will increase.



# *Instruction Manual*



**SPDE CXP**

No Till Seed Drill Special

BALDAN IMPLEMENTOS AGRÍCOLAS S/A.  
CNPJ: 52.311.347/0009-06  
Insc. Est.: 441.016.953.110



Scan the QR Code on the  
identification plate of your  
device and access this  
Instruction Manual online.

**BALDAN**

# TABLE OF CONTENTS

<b>WARRANTY</b> .....	<b>8</b>
<i>Product Warranty</i> .....	8
<b>GENERAL INFORMATION</b> .....	<b>9</b>
<i>Owner</i> .....	9
<b>SAFETY RULES</b> .....	<b>10 - 12</b>
<b>WARNINGS</b> .....	<b>13</b>
<b>COMPONENTS</b> .....	<b>14</b>
<i>SPDE CXP - No Till Seed Drill Special</i> .....	14
<b>TECHNICAL SPECIFICATIONS</b> .....	<b>15</b>
<b>ASSEMBLY</b> .....	<b>16</b>
<i>Coupling Head Assembly</i> .....	16
<i>Roller Assembly</i> .....	17
<i>Assembly of the Fine Seeds Box (Pasture) Optional</i> .....	17 - 18
<i>Optional Front Line Marker Assembly</i> .....	19 - 20
<i>Mechanical Side Transport Assembly - Optional</i> .....	21
<i>Hydraulic Side Mount Assembly - Optional</i> .....	22 - 24
<b>COUPLER</b> .....	<b>25</b>
<i>Coupling on the Tractor</i> .....	25
<b>LEVELING</b> .....	<b>26</b>
<i>Leveling of the Seeder</i> .....	26
<b>TRANSPORT</b> .....	<b>27</b>
<i>Procedure for Transportation</i> .....	27
<b>WORK</b> .....	<b>28</b>
<i>Procedure for Work</i> .....	28
<b>WORK / TRANSPORT</b> .....	<b>29</b>
<i>Fixation System and Wheel Articulation</i> .....	29
<i>Using the Ladder</i> .....	29
<b>SPACING</b> .....	<b>30</b>
<i>Spacing Between Lines</i> .....	30
<i>Number of Even Lines</i> .....	30
<i>Number of Odd Lines</i> .....	30
<i>Spacing Tables in Millimeters</i> .....	31
<i>New Spacings</i> .....	32 - 33
<b>ADJUSTMENTS</b> .....	<b>34</b>
<i>Adjusting of the Line Markers</i> .....	34
<i>Adjusting of the Line Marker Discs</i> .....	35
<i>Adjusting of the Line Marker Bar</i> .....	35
<i>Finishing System</i> .....	36
<b>SEED DISTRIBUTION SYSTEM</b> .....	<b>37</b>
<i>Seed Adjustment</i> .....	37 - 38

Adjustment for Seed Distribution .....	38 - 39
To calculate the amount of Fertilizer and Seed per Ha or AA, One should: .....	39
Adjustment of the Fine Seed Box (Pasture) - Optional .....	40
<b>FERTILIZER DISTRIBUTION SYSTEM .....</b>	<b>41</b>
Independent Fertilizer Distribution System .....	41
Fertisystem Fertilizer Distribution System - Optional .....	42
Speed Box .....	43
Adjustment for Fertilizer Distribution .....	43
Fertilizer Distribution Table per Hectare 20/31 - SPDE CXP .....	44
Distribution Table for Fertilizer per Hectare 31/20 - SPDE CXP .....	45
<b>CALCULATION .....</b>	<b>46</b>
Practical Calculation for Fertilizer Distribution .....	46
Practical Test to Assess the Quantity of Fertilizer and Seed Distribution .....	47
<b>PLANTING LINES .....</b>	<b>48</b>
Optional Line Models .....	48 - 55
<b>ADJUSTMENT OF THE LINES .....</b>	<b>56</b>
Spring Pressure Adjustment .....	56
Limiters .....	57
Depth Limiter Flange .....	57
Adjustment of the "V" Compactor Wheel .....	57
Adjustment of the Iron Compactor Wheel - Optional .....	58
Adjustment of the Slit or Plain Cutting Disc .....	59
Adjustment of Angle and Depth Limiter Wheel Depth .....	59
Compactor Wheel Regulation - Optional .....	60
Adjustment of the Double Disk Cleaners .....	60
<b>OPERATION .....</b>	<b>61</b>
Counterweights .....	61
Recommendations for Operation .....	62
<b>MAINTENANCE .....</b>	<b>63</b>
Tire Pressure .....	63
Lubrication .....	63
Table of Grease and Equivalents .....	63
Lubricate Every 10 Hours of Work .....	65 - 65
Lubricate Every 30 Hours of Work .....	66
Lubricate Every 60 Hours of Work .....	66
Lubricate Every 200 Hours of Work .....	67
Chain Tension .....	67
Oscillating Stretcher .....	67
Operational Maintenance .....	68
Care .....	68 - 69

## TABLE OF CONTENTS

# TABLE OF CONTENTS

Cleaning .....	69
Seeder conservation .....	69 - 70
Cleaning the Fertisystem Driver .....	71
Fertisystem Conductor Maintenance Tube .....	72
Fertisystem Conductor Blocking Tube .....	73
Spring and Caps (Optional) Fertisystem driver .....	73
<b>OPCIONALS .....</b>	<b>74</b>
Cpl Iron Wheel Cart .....	74
Cpl Compactor Wheels .....	74
Limiter flange w/ Cleaner .....	75
Mechanical Side Transport Kit .....	76
Hydraulic Side Transport Kit .....	76
Fine Seeds Box Cpl .....	77
Cpl Line Marker System w/Steering .....	77
ETD System (Electronic Dosing Table) .....	78
<b>ETD MANUAL .....</b>	<b>79</b>
Presentation .....	79
Mounting the magnets on the main axis .....	80
Mounting the speed sensor .....	80
Speed sensor installation .....	81
Identification .....	81
Settings menu .....	82
Sensor calibration .....	82
Machine .....	83
Sensor machine .....	83
Seed rate .....	84
Fertilizer rate .....	84 - 85
Total calculation .....	85
Calibrate fertilizer .....	85 - 86
F3 Hour meter .....	87
F4 Hectometer .....	87
Settings menu .....	88
Sensor calibration .....	88 - 89
Machine .....	89 - 90
Time above maximum speed .....	90
<b>IDENTIFICATION .....</b>	<b>91</b>
Product Identification .....	91
<b>NOTES .....</b>	<b>92 - 93</b>
<b>CERTIFICATE .....</b>	<b>94</b>
Warranty Certificate .....	94 - 96

**PRODUCT WARRANTY**

**BALDAN IMPLEMENTOS AGRÍCOLAS S/A**, ensures normal operation of the tool to the dealer for a period of six (6) months from the delivery date on the resale invoice to the first end consumer.

During this period **BALDAN** undertakes to remedy defects in materials and/or workmanship of their responsibility, and the labour, freight and other expenses of the responsibility of the dealer.

During the warranty period, the order and replacement of any defective parts must be made to the dealer in the region, who will send the defective part for analysis at **BALDAN**.

When such a procedure is not possible and exhausted the resolution capacity of the dealer, the dealer will request support from the Technical Assistance of **BALDAN**, through the specific form distributed to resellers.

After analysing the items replaced by the Technical Assistance of **BALDAN**, and concluded that it is not a warranty issue, so it will be of responsibility of the reseller any costs related to replacement; as well as the cost of materials, travel including accommodation and meals, accessories, lubricant and other expenses resulting from the call to the service, with the **BALDAN** company being authorised to make its billing on behalf of the reseller.

Any repairs made to the product that is within the warranty period of the dealer will only be authorized by **BALDAN** with prior presentation of the budget describing the work of parts and labor to be performed.

It is excluded from this term the product that is repaired or modified in shops that do not belong to the dealer network of **BALDAN**, as well as the use of non-genuine parts or components in the product of the customer

This guarantee will be void when it is determined that the defect or damage is the result of improper product use, failure to follow instructions or the inexperience of the operator.

It is agreed that this warranty does not cover tires, polyethylene tanks, drive shafts, hydraulic components, etc., which is equipment guaranteed by their manufacturers.

Manufacturing and or material defects, object of this warranty term, will not constitute, under any circumstances, a reason for termination of the purchase and sale contract or compensation of any nature.

**BALDAN** reserves the right to modify and or improve the technical characteristics of its products without notice and without obligation so to proceed with the products previously manufactured.

**GUARANTEE**

# OVERVIEW

## OWNER

**BALDAN IMPLEMENTOS AGRÍCOLAS S/A**, is not liable for any damage caused by accidents arising from the use, transportation or improper or incorrect storage of your tool, whether due to negligence and/or inexperience of any person.

Only persons with full knowledge of the tractor and the tool may carry out the transportation and operation of the same.

**BALDAN** shall not be liable for any damage caused in unforeseeable or unrelated situations to the normal use of the tool.

*The mishandling of this equipment can result in serious or fatal accidents. Before putting the equipment into operation, please read the instructions in this manual. Ensure that the person responsible for the operation is instructed in the correct and safe handling of it. Also make sure that the operator has read and understood the instruction manual of the product.*



**NR-31 - SAFETY AND HEALTH AT WORK IN AGRICULTURE, FORESTRY, FOREST EXPLORATION AND AQUACULTURE.**

*The purpose of this Regulatory Standard is to establish the precepts to be observed in the organization and in the work environment, in a manner compatible with the planning and development of agriculture, livestock, forestry, forestry exploration and aquaculture activities with safety and health and work environment.*

**OWNER OR OPERATOR OF THE EQUIPMENT.**

*Please read and follow the NR-31 standard carefully.*

*For more information, check the website and read the full NR-31.  
<http://portal.mte.gov.br/legislacao/normas-regulamentadoras-1.htm>*



*THIS SYMBOL INDICATES AN IMPORTANT SAFETY WARNING. PLEASE READ THIS MANUAL CAREFULLY WHEN YOU COME ACROSS IT BE AWARE OF THE CONTENT AHEAD AND PAY ATTENTION TO THE POSSIBILITY OF PERSONAL ACCIDENTS.*

**! ATTENTION**

- Read the instruction manual carefully for recommended safety practices.

**! ATTENTION**

- Only start the tractor when you are properly seated and the seat belt is locked.

**! ATTENTION**

- Do not operate the tractor if the front is light. If there is a tendency to lift, add weights to the front or front wheels.

**! ATTENTION**

- There are risks of serious injury by overturning when working on slopes.
- Do not use excessive speed.

**! ATTENTION**

- Do not carry personnel on the tractor and neither inside nor on the equipment.

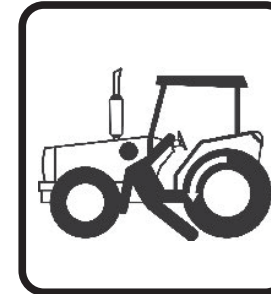
**! ATTENTION**

- Before carrying out any maintenance on your equipment, make sure that it is properly stationary. Avoid getting run over.

**SAFETY NORMS**

## SAFETY NORMS

### ! ATTENTION

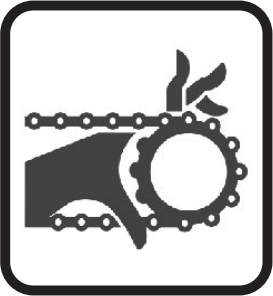

- When doing any services on the seeder transmission, first switch off the tractor.
- Do not make adjustments with the seeder in operation.

### ! ATTENTION



- When operating the seeder do not allow that people be on the machine.
- Do not stay on the platforms with the seeder in operation.

### ! ATTENTION



- Keep yourself away from the moving elements of the seeder (Discs), as they are sharp and can cause accidents.
- When making any service on the discs wear safety gloves on your hands.

### ! ATTENTION



- The hydraulic oil is pressurized and can cause serious injury if leaks occur. Periodically check the conservation status of the hoses. If there is any evidence of leakage, replace immediately.
- Before you connect or disconnect the hydraulic hoses, relieve the system pressure by triggering the command with the tractor off.

### ! ATTENTION

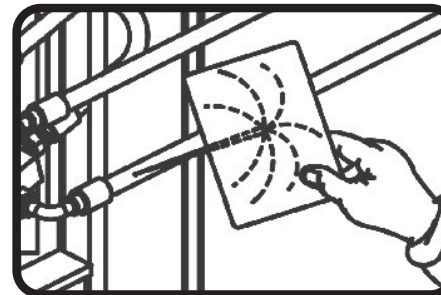

- When looking for a leak in the hoses, use a piece of cardboard or wood, never use your hands.
- Avoid fluids going into the skin.



**THIS SYMBOL INDICATES AN IMPORTANT SAFETY WARNING. PLEASE READ THIS MANUAL CAREFULLY WHEN YOU COME ACROSS IT BE AWARE OF THE CONTENT AHEAD AND PAY ATTENTION TO THE POSSIBILITY OF PERSONAL ACCIDENTS.**

**! ATTENTION**



- When transporting this seeder, do not exceed the speed of 16km/h or 10 MPH, thus avoiding risk of damage or accidents.



**! ATTENTION**

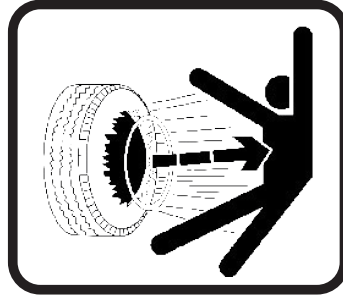

- Never weld the wheel with the tire mounted, the heat may cause increased air pressure and cause the tire to explode.
- When filling the tire, position yourself next to the tire, never in front of it.

**! ATTENTION**

- Do not make adjustments with the seeder in operation.
- When performing any service on the seeder, switch off the tractor.

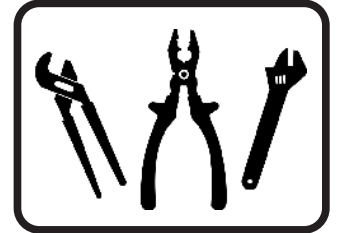

**! ATTENTION**



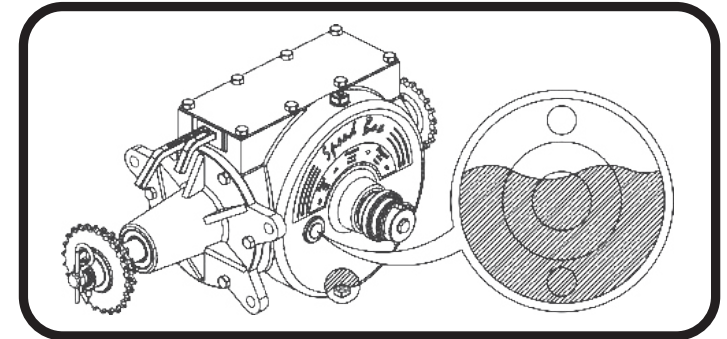











- Check the oil level daily.
- Change the oil from the gearbox after the first 30 hours, and after that, every 1500 hours when using mineral oil ISO BV 150 at 40°C (amount of oil used is 1.8 litres).
- Use only an original factory fuse because only it has controlled hardness.



*THIS SYMBOL INDICATES AN IMPORTANT SAFETY WARNING. IN THIS MANUAL, WHENEVER YOU FIND IT, PLEASE READ THE MESSAGE BELOW CAREFULLY AND BE ATTENTIVE TO THE POSSIBILITY OF PERSONAL ACCIDENTS*

**SAFETY NORMS**

## WARNINGS

- 01 -  When operating the equipment, do not allow people to stay very close to it or on it.
- 02 -  When making any assembly and dismantling service on the discs wear gloves on your hands.
- 03 -  Do not wear loose clothing as it can curl up on the equipment.
- 04 -  When operating the tractor's engine, be properly seated on the operator's seat and be aware of the complete working of the tractor for both the tractor and the tool. Always turn the gearshift lever to neutral, disconnect the power socket and put the hydraulic controls to the neutral position.
- 05 -  Do not run the engine indoors without adequate ventilation, as the exhaust gases are harmful to health.
- 06 -  When maneuvering the tractor to couple the implement, make sure that you have the necessary space and that there are no people very close. Always perform maneuvers in a low gear and be prepared to brake in an emergency.
- 07 -  Do not make adjustments with the tool in operation.
- 08 -  When working on sloping terrains, proceed with caution when trying to maintain the necessary stability. In the event of imbalance, reduce the throttle, turn the tractor wheels towards the downslope of the terrain.
- 09 -  Always drive the tractor at speeds compatible with safety, especially when working in rough terrain or slopes. Always keep the tractor engaged.
- 10 -  When driving the tractor on roads, keep the brake pedals connected and use safety signs.
- 11 -  Do not operate the tractor if the front is light. If there is a tendency to lift, add weights at the front or on the front wheels.
- 12 -  When leaving the tractor put the gear lever in neutral and apply the parking brake.
- 13 -  Alcoholic drinks or some types of medication can generate a loss of reflexes and change the physical conditions of the operator. Therefore, never operate this under the effect of these substances.
- 14 -  Read or explain all of the above to the user who can not read.

*In case of doubt, consult the After Sales Service.  
Telephone: 0800-152577 / E-mail: posvenda@baldan.com.br*

**SPDE CXP  
NO TILL SEED DRILL SPECIAL**

- 1- Amount
- 2- Spring Rod
- 3- Regulator
- 4- Hoses Support
- 5- Leaf Spring Shackle
- 6- Coupling Head
- 7- Hydraulic Head
- 8- Line Drive Cylinder
- 9- Telescopic Driver
- 10- Speed Box
- 11- Line
- 12- Support Arm
- 13- Cutting Disc
- 14- Tire Activation Cylinder
- 15- Manual Container
- 16- Tires
- 17- Seed Regulator
- 18- Platform
- 19- Platform Handrail
- 20- Fertilizer Storage
- 21- Seed Storage

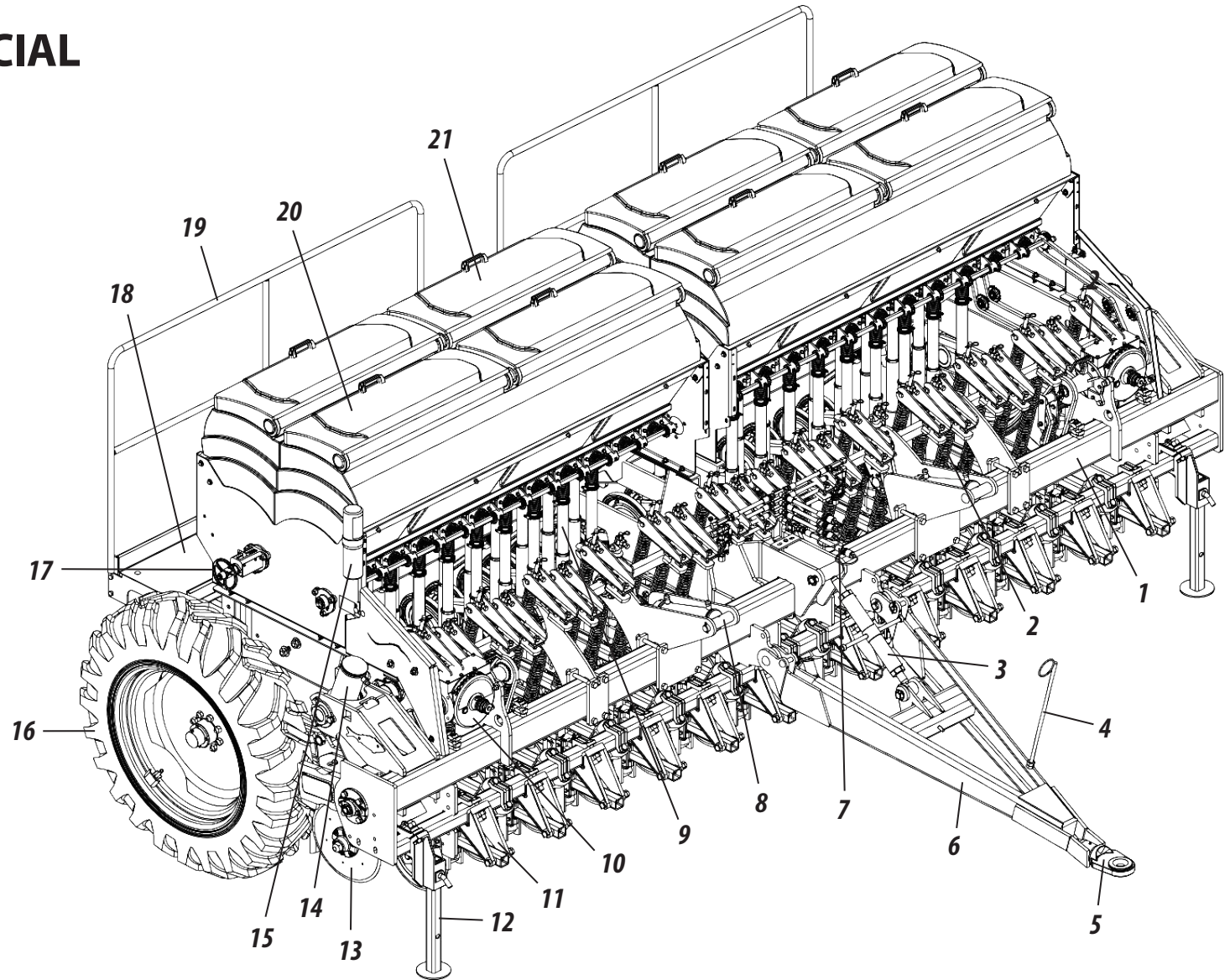

**COMPONENTS**

# TECHNICAL SPECIFICATIONS

<i>Model</i>	<i>No. of Lines</i>	<i>Width Useful (mm)</i>	<i>Width Total (mm)</i>	<i>Width of Work (mm)</i>	<i>Capac. Storage of Fertilizer (L)</i>	<i>Capac. Storage of Seeds (L)</i>	<i>Capac. Storage of Fine Seeds (L)</i>	<i>Weight (Approx.) (kg)</i>	<i>Power (Approx.) (Hp)</i>
<i>SPDE CXP 3000</i>	16	2550	3592	2720	660	564	108	3431	75 - 95*
<i>SPDE CXP 4000</i>	20	3230	4272	3400	810	700	120	3830	95 - 110*
<i>SPDE CXP 5000</i>	24	3910	4952	4080	972	836	148	4250	115 - 130*

*Working Depth (mm)* ..... 0 - 120

*Free Height (mm)* ..... 1850

*Minimum spacing between lines (mm)* ..... 170

*Amount of Water in the Tires (L)* ..... 3/4"

*Overall Length (mm)* ..... 3600

*Wheel set* ..... 12.4 x 28 x 6 L

*(\*) Approximate power (hp) depends on the normal conditions for planting and may vary according to the type of soil, topography, etc*

*Baldan reserves the right to modify and or improve the technical characteristics of its products without notice and without obligation so to proceed with the products previously manufactured. The technical specifications are approximate and informed in normal working conditions.*

The **SPDE CXP** leaves the factory semi-assembled, lacking only the mounting of some components, to be mounted as indicated below:

**COUPLING HEAD ASSEMBLY**

To mount the coupling head (1) to the **SPDE CXP**, proceed as follows:

- 1- Insert the coupling head (1) into the working position, removing the (2), the pins (3) that have been placed for the transport of the seeder.

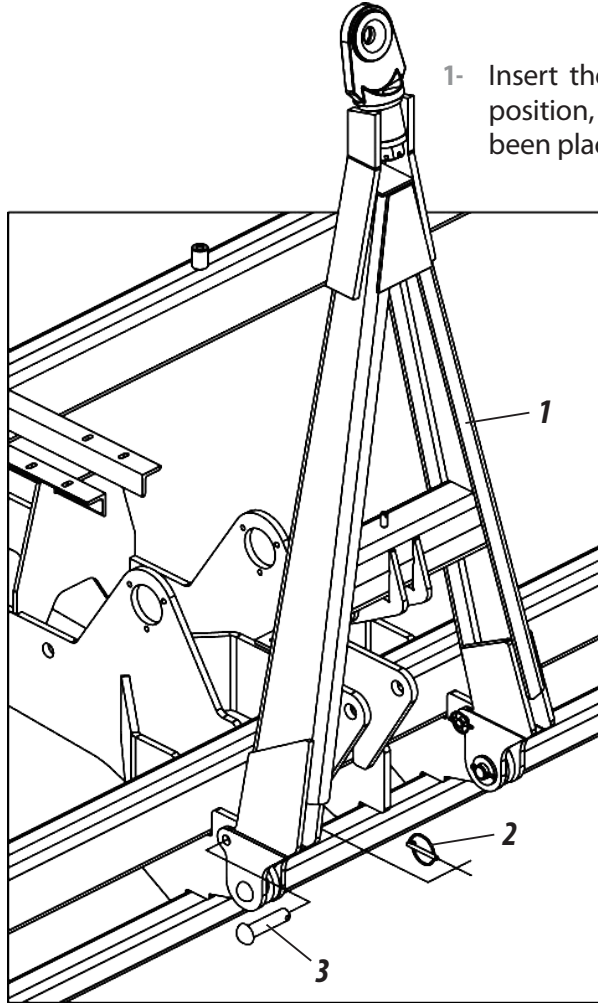

- 2- Then insert the adjuster (4) into the coupling head (1), securing it with the pin (5) and locking ring (6) and the mount (7) with pin (8) and latch with ring (9).

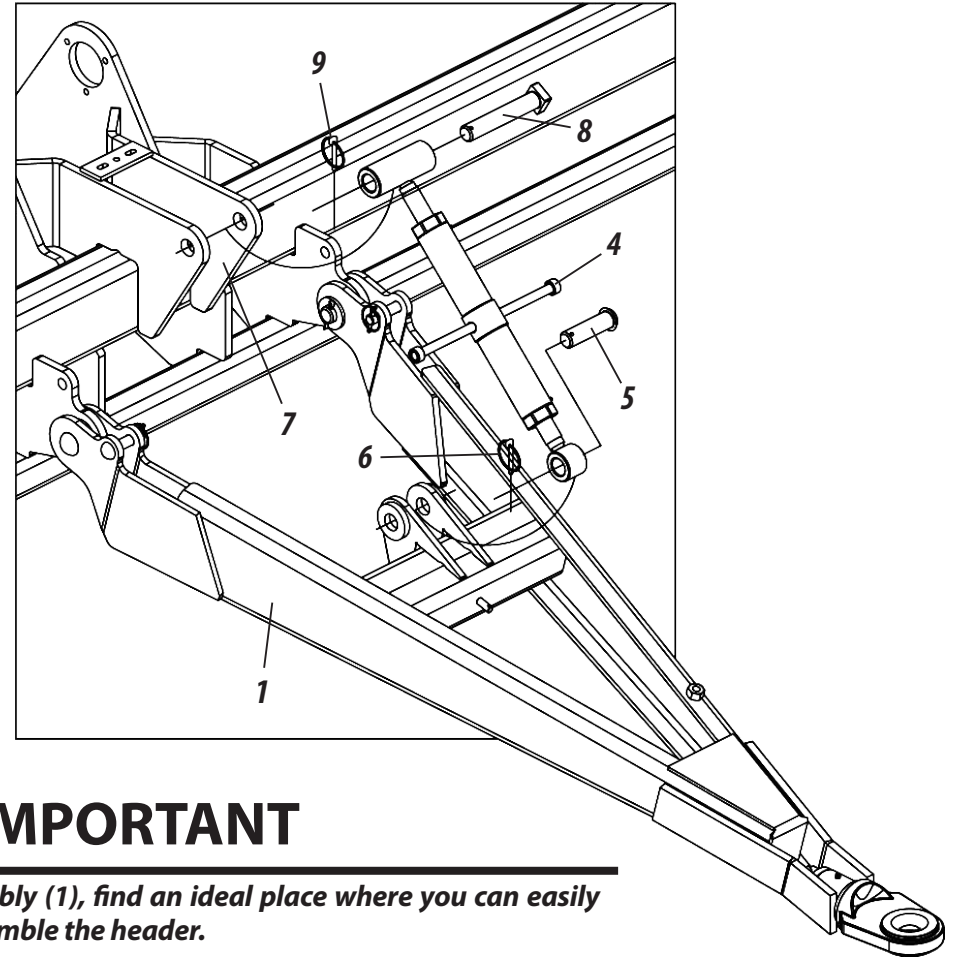

**IMPORTANT**

*Before starting the header assembly (1), find an ideal place where you can easily identify the components and assemble the header.*

# ASSEMBLY

## ROLLER ASSEMBLY

To mount the "V" wheel holder (1), proceed as follows:

- 1- Attach the "V" wheel bracket (1) on line (2), securing it through the bolts (3), lock washers (4) and nuts (5).

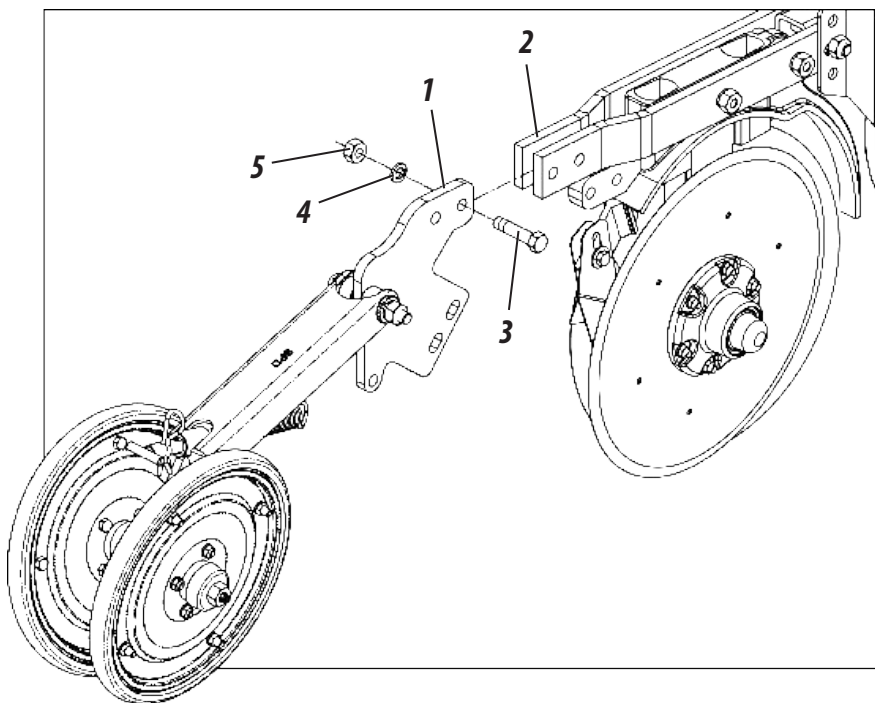

### NOTE

Repeat the above procedure to assemble the other lines of the seeder.

## ASSEMBLY OF THE FINE SEEDS BOX (PASTURE) OPTIONAL - PART I

To assemble the fine seed box (1), proceed as follows:

- 1- First, secure the plates (2) on the tank support (3) through the bolts (4), plain washers (5), lock washers (6) and nuts (7).

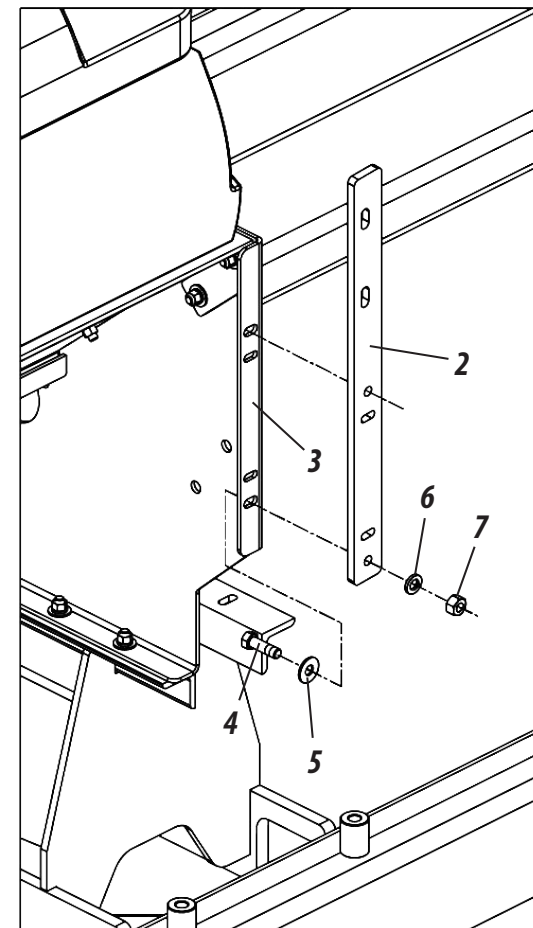
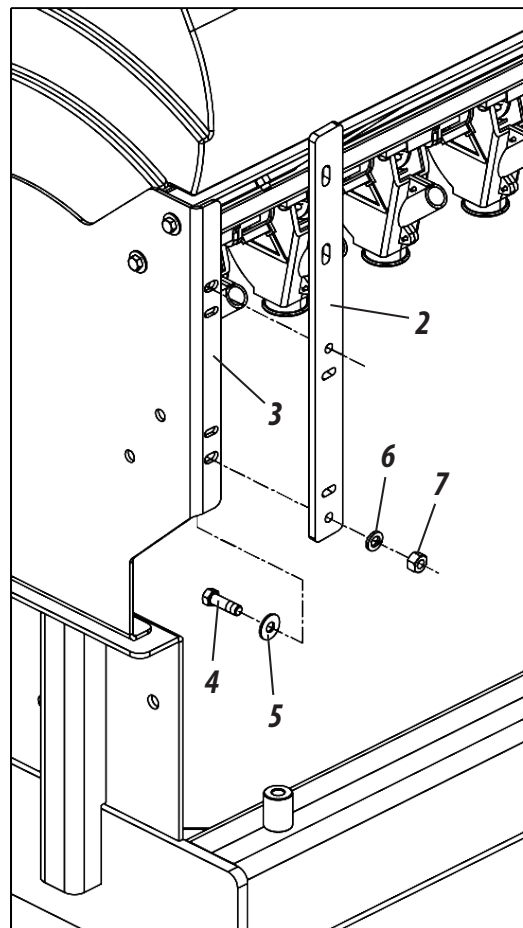

**ASSEMBLY OF THE FINE SEEDS BOX (PASTURE) - OPTIONAL PART II**

- 2- Then secure the fine seed box (1) to the plates (2) using bolts (8), plain washers (9), spring washers (10) and nuts (11).
- 3- Then secure the tensioner (12) on the tank support (3) through the plain washer (13), washer (14) and nut (15).
- 4- Then, secure the tensioner (16) through the bolt (17), flat washer (18), washer (19) and nut (20).
- 5- Then place the chain (21) between the gears of the fine seed box and seed shaft, tension the chain through the tensioners (12 and 16).
- 6- Finish by attaching the protective cap (22) to the plates (2) through the screws (23), plain washers (24), pressure washers (25) and butterfly nuts (26).
- 7- Finish by attaching the hose (27) to the transmission box (28).

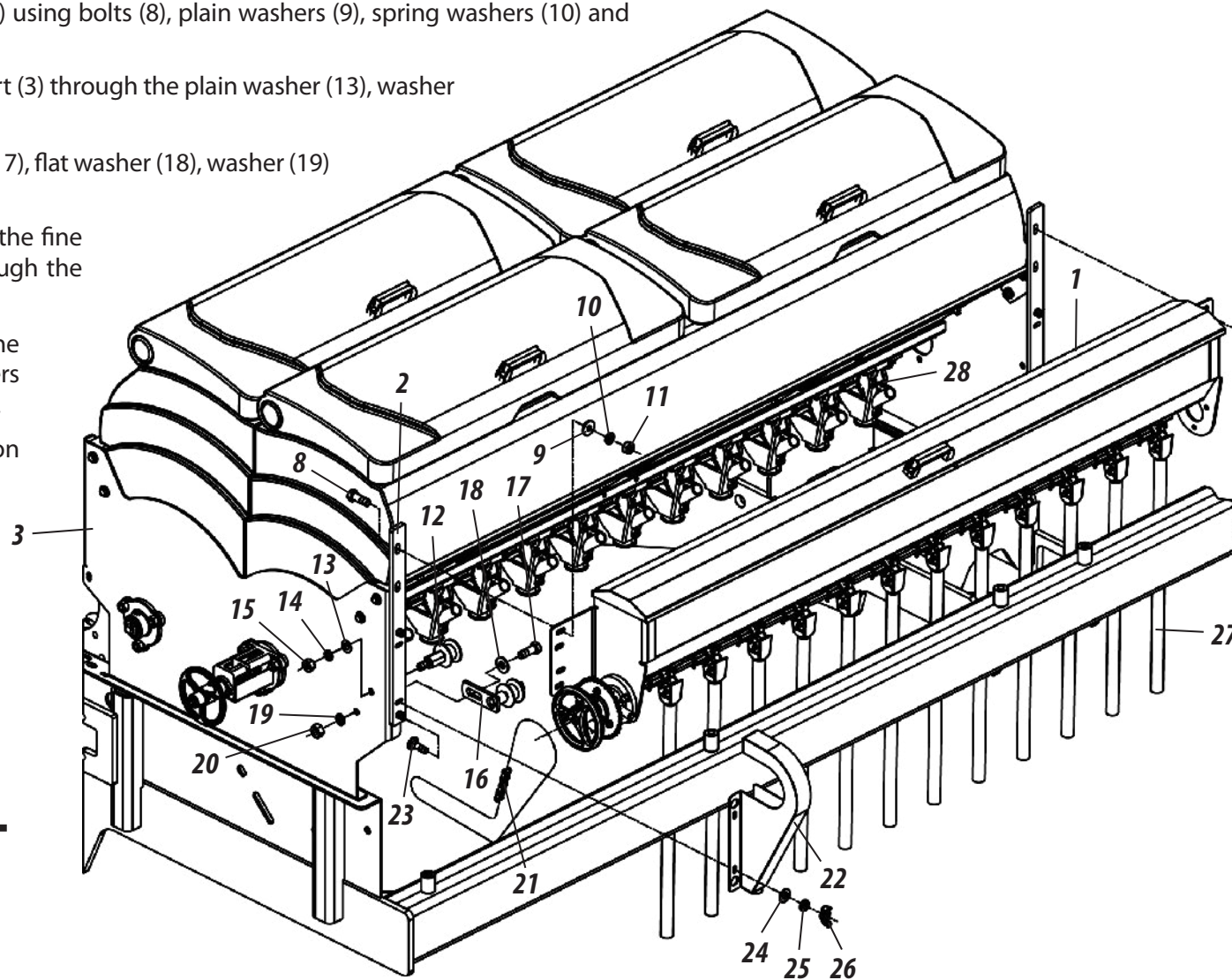

**! ATTENTION**

*When completing the fine seed box assembly (1), make a general inspection of the seeder, check that there are no objects (nuts, bolts or other) inside the tanks. Retighten all bolts and nuts, check all pins, cotter pins and latches, check all hoses.*

**ASSEMBLY**

# ASSEMBLY

## FRONT LINE MARKER ASSEMBLY OPCIONAL - PART I

To assemble the front line marker (optional), proceed as follows:

- 1- Attach the bracket (1) to the support (2) through the bolts (3), lock washers (4) and nuts (5).
- 2- Then secure the steering (6) on the support (1) through the bushings (7), screws (8), spring washers (9) and nuts (10).
- 3- Then insert the bar (11) into the steering (6) and fix it with the screw (12).
- 4- Attach the hydraulic cylinders (13) to the steering (6) through the pin (14), flat washer (15) and cotter pin (16) and the hydraulic cylinder rods with pin (17), flat washer (18) and (19).
- 5- Finally, secure the chain (20) through the pressure washer (21) and bolt (22).

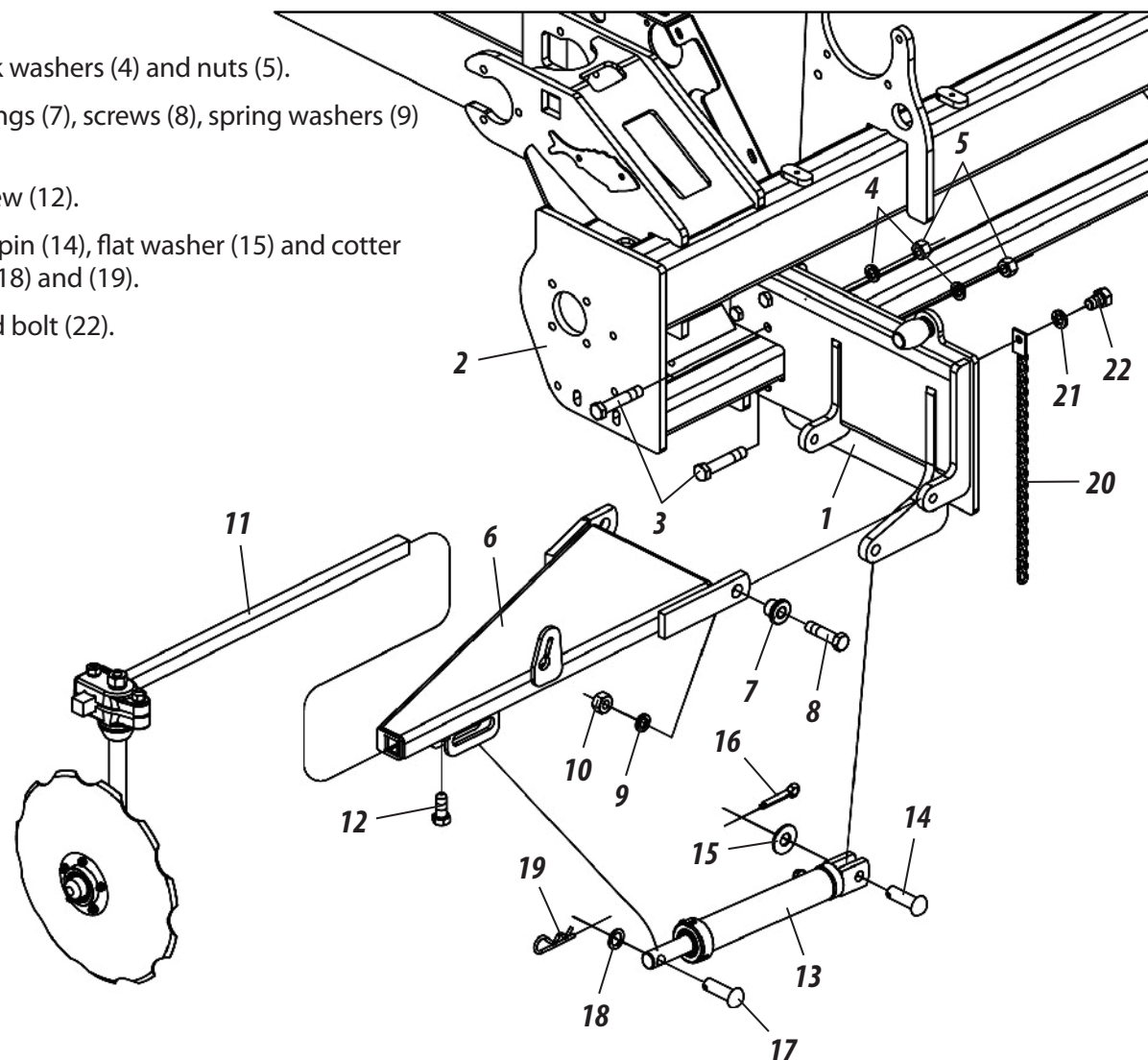

### NOTE

*When you finish setting up the front right line marker, repeat the above procedure to assemble the left front line marker.*

*When finalizing the markers assembly, assemble the hydraulic system as instructed on the following page.*

### OPTIONAL FRONT LINE MARKER ASSEMBLY - PART II

After assembling the line markers, assemble the hydraulic system, and for this, proceed as follows:

- 1- Attach the valve (23) on the mount (24) through the bolts (25), pressure washers (26) and plain washers (27).
- 2- Then, attach the hydraulic hoses (28 and 29) to the valve (23).
- 3- Then, attach the hydraulic hoses (28 and 29) to the hydraulic cylinders (30 and 31).
- 4- Finish by attaching the hydraulic hoses (32) to the tractor.

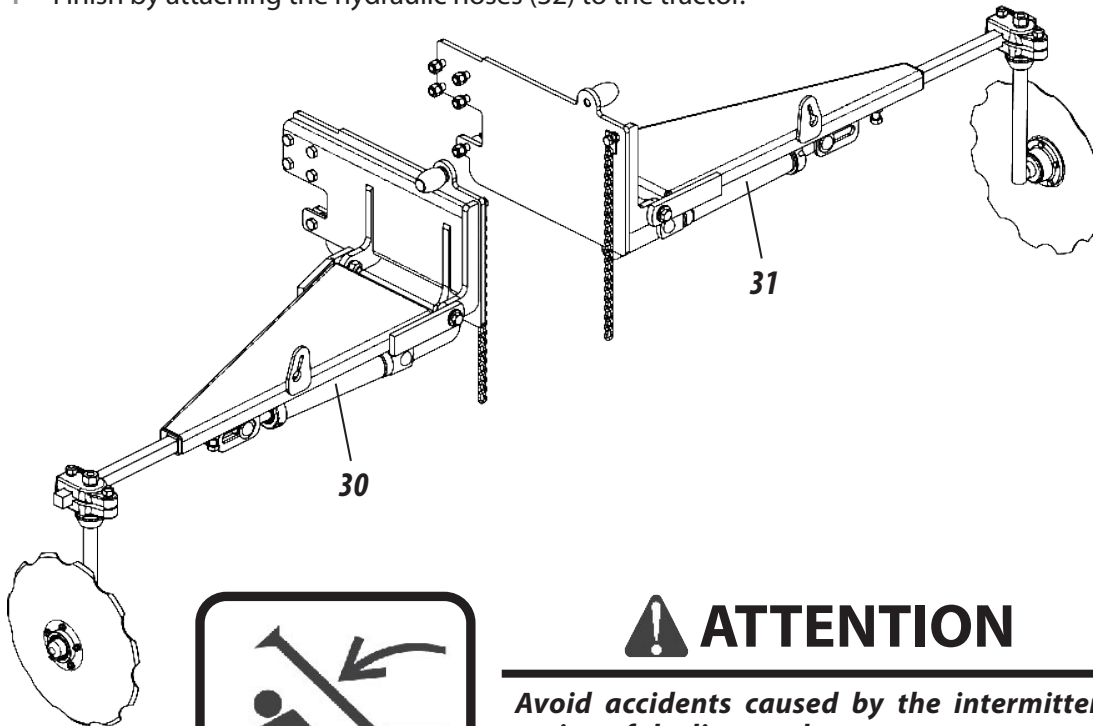

### ⚠ ATTENTION

*Avoid accidents caused by the intermittent action of the line markers.*

*When operating the seeder, make sure there is nobody under the line markers or in their operating area.*

## ASSEMBLY

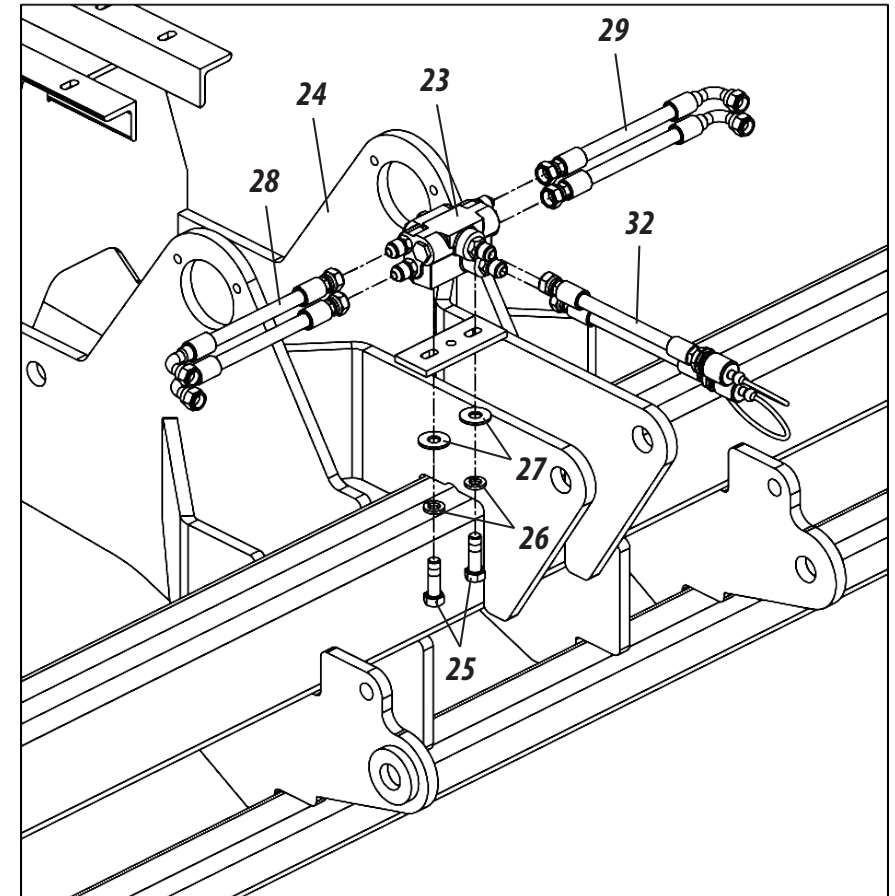

### 📌 NOTE

*The line marker is only used when the seeder is running with the CPD Kit. For fine grain cultivation, do not use the line marker.*

# ASSEMBLY

## MECHANICAL SIDE TRANSPORT ASSEMBLY - OPTIONAL

To assemble the mechanical side transport (optional) on the **SPDE CXP**, Proceed as follows:

- 1- First, remove the nuts (1) and replace the bolts (2) of the wheel (3) by the bolts (4) of the package.
- 2- Then engage the coupling (5), replace the nuts (1) and retighten them.
- 3- Finish by placing the locking nuts (6) of the package.
- 4- Insert the coupling header for the side transport (7) into the coupling (5), through the pin (8) and lock (9).
- 5- Engage the lower arm of the tractor on the support "A" of the header through the pin (10) and latch (11).
- 6- Engage the 3rd point of the tractor (12) on the support "B" of the header through the pin (13) and lock (14).
- 7- Finally with the aid of the regulating lever "C" engage the lower arm of the tractor on the pin "D" of the head.

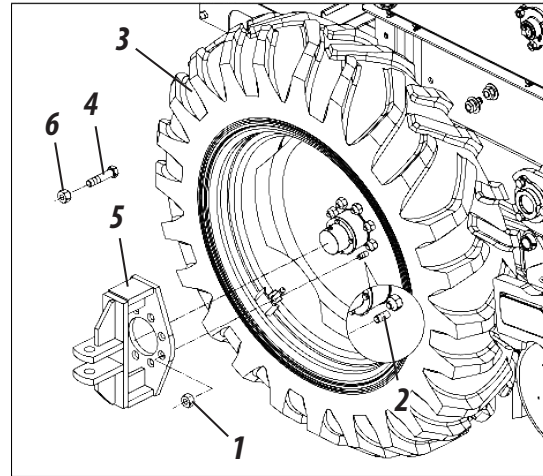

- 8- Attach the side transport bracket (15) to the mount (16) through the plate (17), screws (18) and washers and nuts (19). Then mount the rod with the tire (20) through the pin (21) and latch (22).

### **! ATENTION**

*To lower or lift the side transport bracket (20), raise the seeder with the tractor hydraulics.*

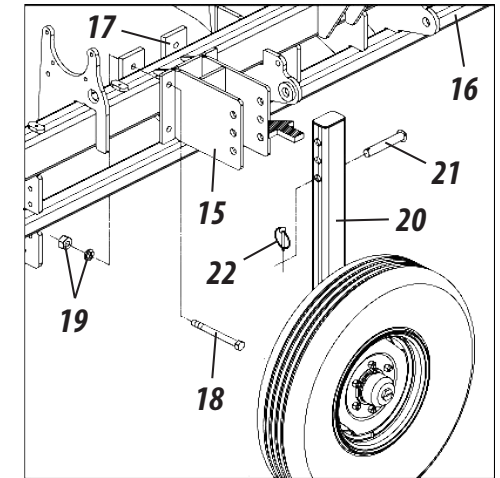

- 9- After engaging the tires, lift the head (23) by locking it with the pin (24) and the latch (25) for the side transport of the seeder.

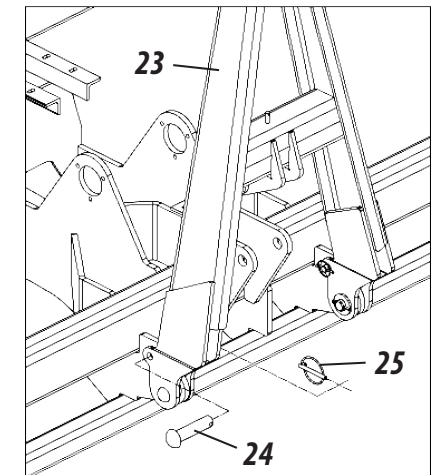
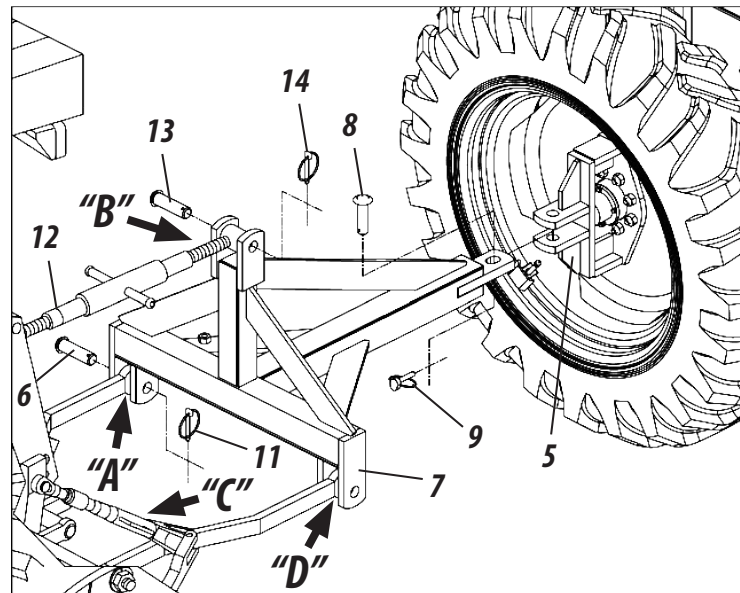

**HYDRAULIC SIDE MOUNT ASSEMBLY - OPTIONAL - PARTE I**

To assemble the hydraulic side transport (optional) on the **SPDE CXP**, proceed as follows:

- 1- First, remove the nuts (1) and replace the bolts (2) of the wheel (3) with the bolts (4) of the package.
- 2- Then engage the coupler (5), replace the nuts (1) and retighten them.
- 3- Finish by placing the locking nuts (6) of the package.
- 4- Insert the coupling head for the side transport (7) into the coupling (5) through the pin (8) and the latch (9).
- 5- Engage the lower arm of the tractor on the support "A" of the head through the pin (10) and latch (11).
- 6- Engage the 3rd point of the tractor (12) on the support "B" of the header through the pin (13) and latch (14).
- 7- Finally with the help of the regulating lever "C" engage the lower tractor arm on the "D" pin of the head.

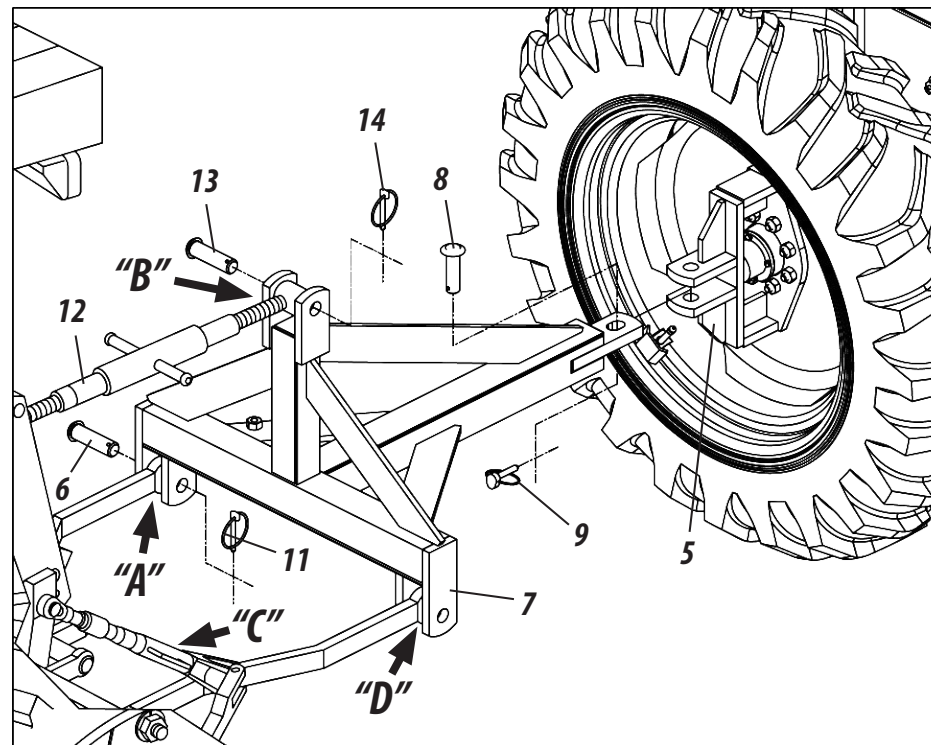
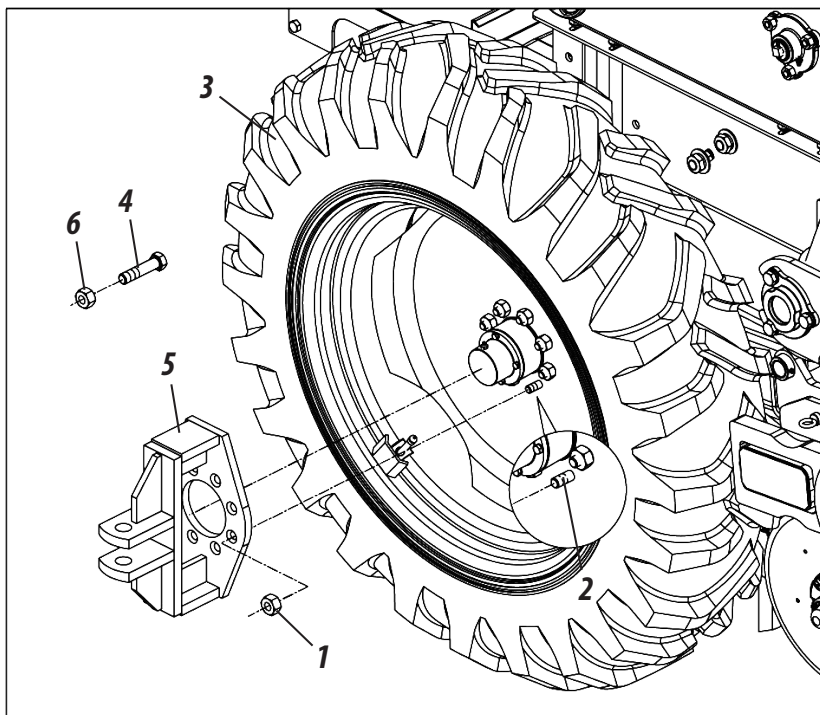

- 4- Insert the coupling head for the side transport (7) into the coupling (5) through the pin (8) and the latch (9).

**ASSEMBLY**

# ASSEMBLY

## HYDRAULIC SIDE MOUNT ASSEMBLY OPTIONAL - OPTIONAL - PARTE II

- 8- Then, secure the hinge bracket (15) to the mount (16) through the palte (17), screws (18) and washers and nuts (19).

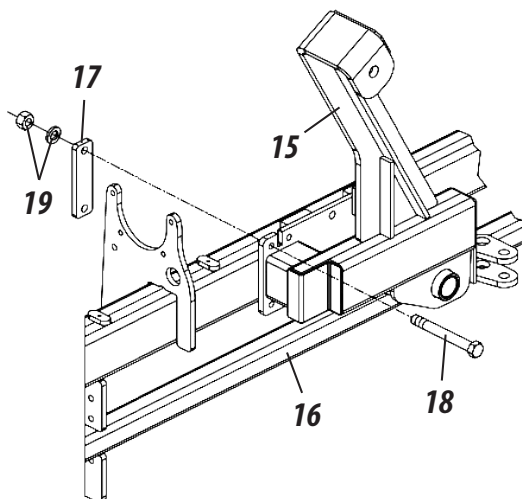

- 9- Then, attach the wheel holder (20) to the hinge support (15), securing through the bracket and nut (21).

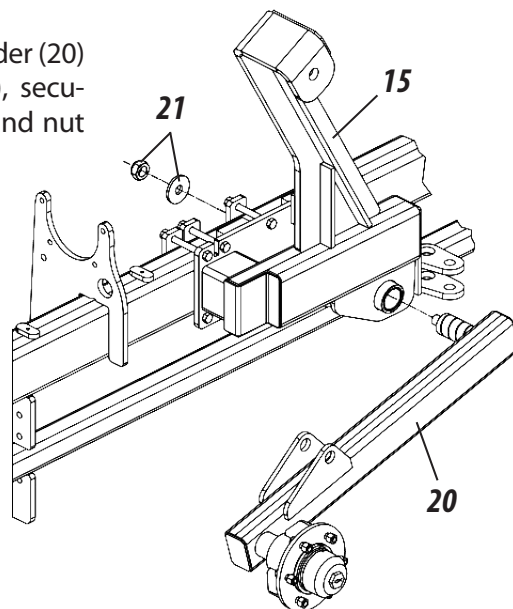

- 10- Then, attach the rear of the hydraulic cylinder (22) to the hinge bracket (15) through the pin (23), flat washer (24) and cotter pin (25) and the rod of the wheel holder (20) through the pin (25), flat washer (26) and cotter pin (27).

### ⚠ ATTENTION

*Note the pin placement (25) so that the latch (27) is not on the side of the tire.*

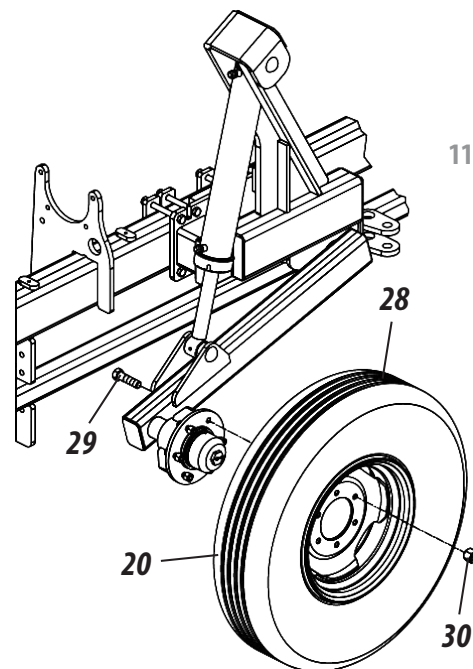

- 11- Then, attach the tire (28) to the wheel holder (20) by fastening it through the screws (29) and nuts (30).

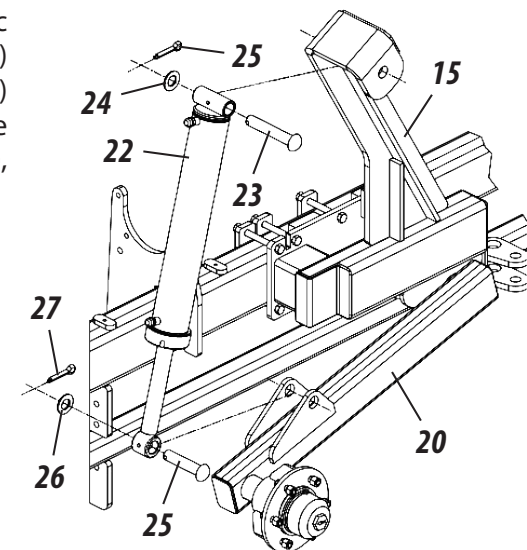

**HYDRAULIC SIDE MOUNT ASSEMBLY OPTIONAL - PARTE III**

12- Then, attach the valve (31) on the hinge support (15) by securing through the screws (32), pressure washers (33) and plain washers (34).

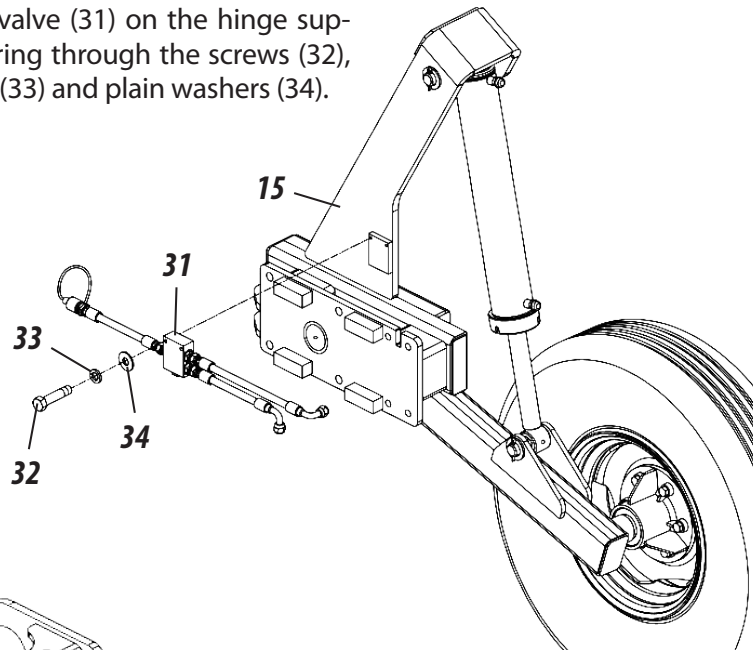

14- After engaging the tires, lift the head (23) by locking it with the pin (24) and latch (25) for lateral transport of the seeder.

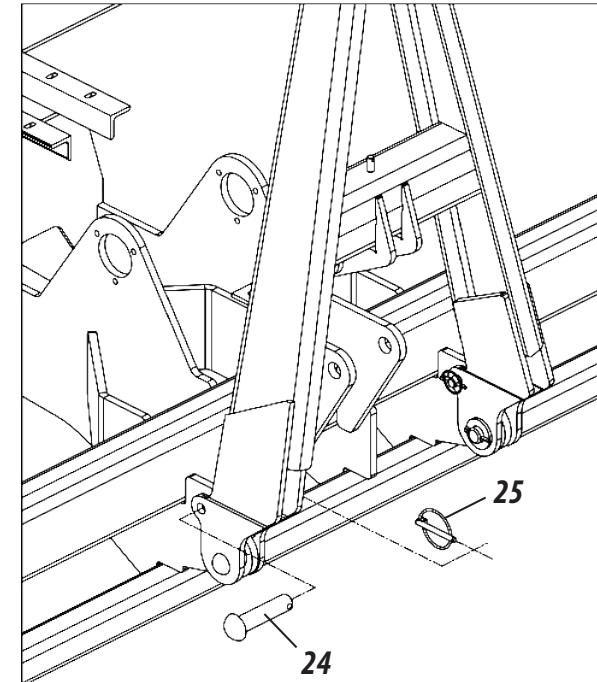

13- Then place the terminal supports (35) on the assembly (16) by fixing with the fastener (36), pressure washers (37) and nuts (38).

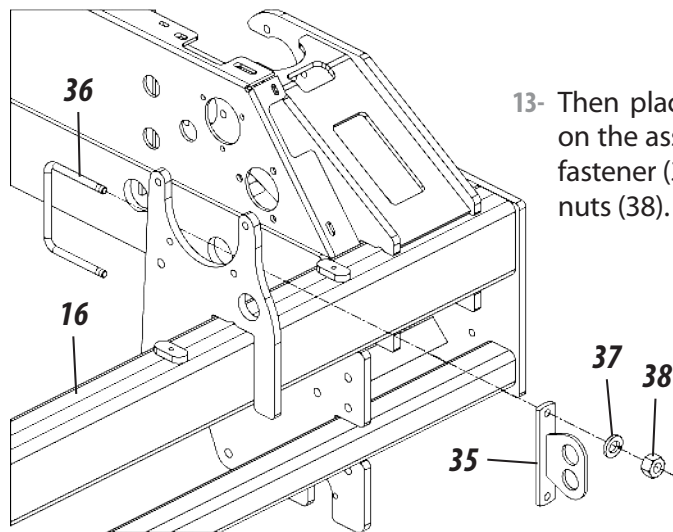
**ASSEMBLY**

# COUPLER

## COUPLING ON THE TRACTOR

Before attaching the seeder on the tractor, check that the tractor is equipped with a set of weights or ballasts on the front or the front wheels to avoid lifting the tractor. The rear wheels will give the tractor greater stability and traction on the ground. To couple the seeder, proceed as follows:

- 1- Approach the tractor slowly to the seeder in reverse gear, paying attention to the application of the brakes.
- 2- Then, level the coupling head (1) of the seeder in relation to the coupling of the tractor through the regulator (2). Then, approach the tractor slowly to the seeder in reverse gear, paying attention to the application of the brakes.
- 3- Then engage the coupling head (1) to the tractor, securing it through the coupling pin (3) and lock (4).
- 4- Then, attach the rest of the hoses (5) to the tractor's quick coupling.

### ATENTION

*Before connecting or disconnecting the hydraulic hoses, turn off the engine and relieve the hydraulic system pressure by fully operating the control levers. When relieving the system pressure, make sure that no one is near the moving area of the equipment.*

### IMPORTANT

*When engaging the seeder find a safe and easily accessible place, always use a low gear with low acceleration.*

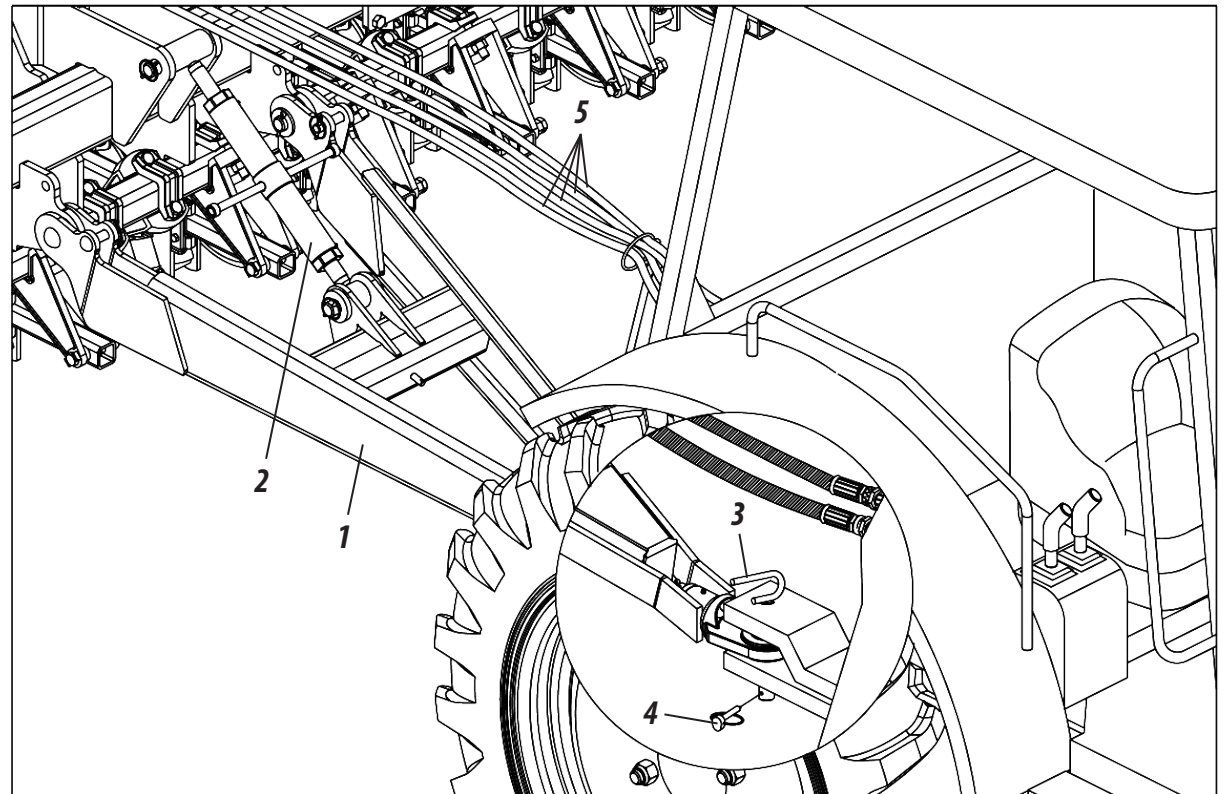

**LEVELING OF THE SEEDER**

At the end of the coupling of the **SPDE CXP**, level it by doing the following:

- 1- Place the tractor and seeder in a flat location.
- 2- Then completely raise the lines by activating the hydraulic cylinders.
- 3- Then level the seeder by using the regulator (1).

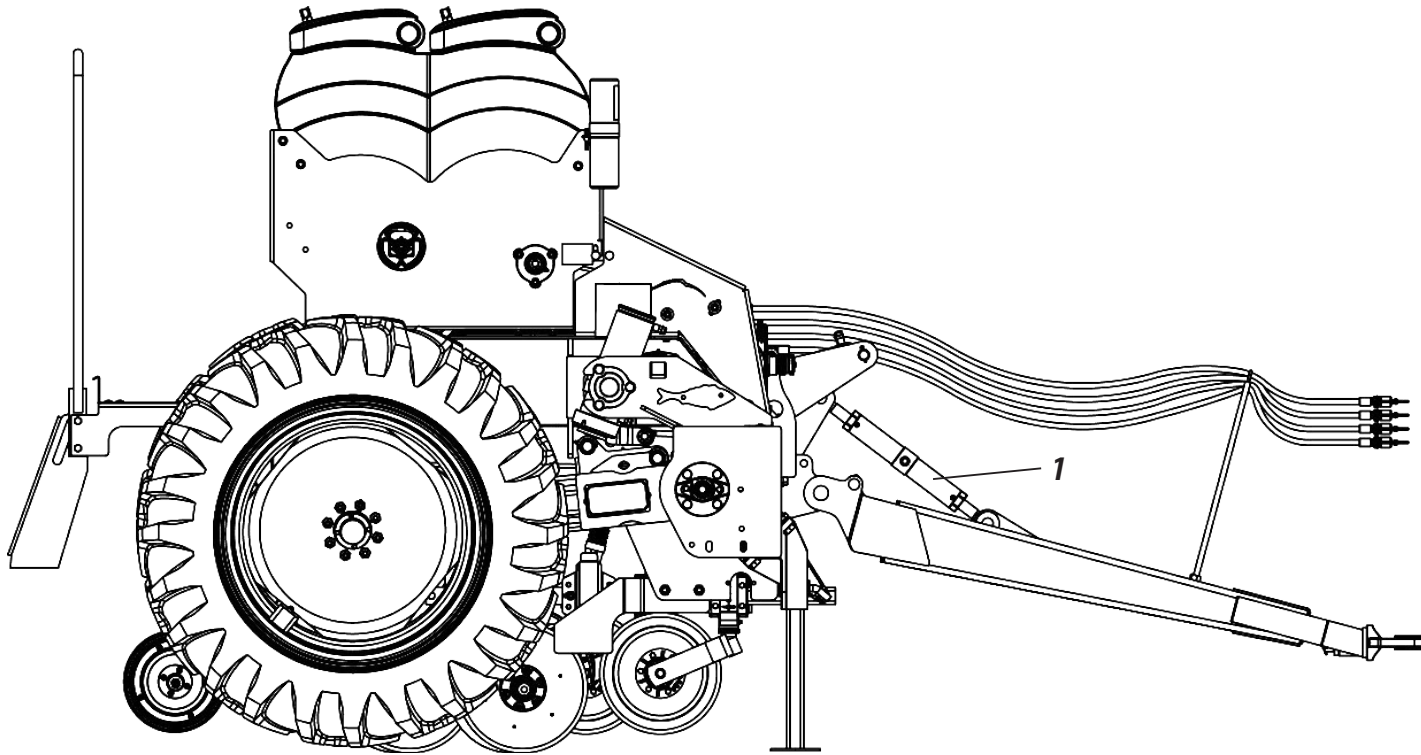
**LEVELLING****NOTE**

*The leveling adjustment varies according to the tractor model.*

# TRANSPORT

## PROCEDURE FOR TRANSPORTATION

Before transporting the seeder, proceed as follows:

- 1- Bring the support bracket back (1) and secure with the pin (2) and lock (3).

### IMPORTANT

**Do not carry a loaded seeder as this may damage it. We recommend filling it only in the workplace.**

**If the seeder is to remain in the field for any reason, we recommend that it be covered with an impermeable tarpaulin to avoid moisture.**

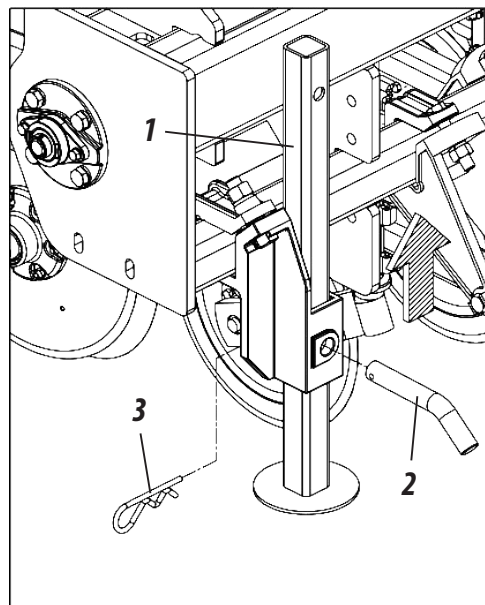

- 3- Fully activate the wheel cylinders (8) and close the valve (9), then relieve the pressure of them.

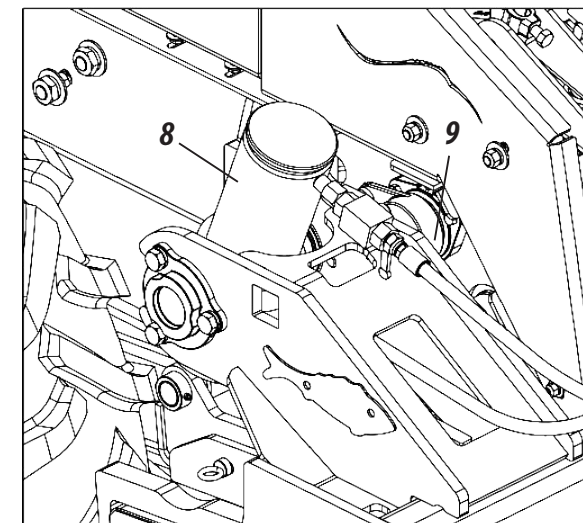

- 2- Then lift the lines by fully activating the reach of the cylinders and place the lock (4) on the rods of the central cylinders (5) locking with the pin (6) and lock (7).

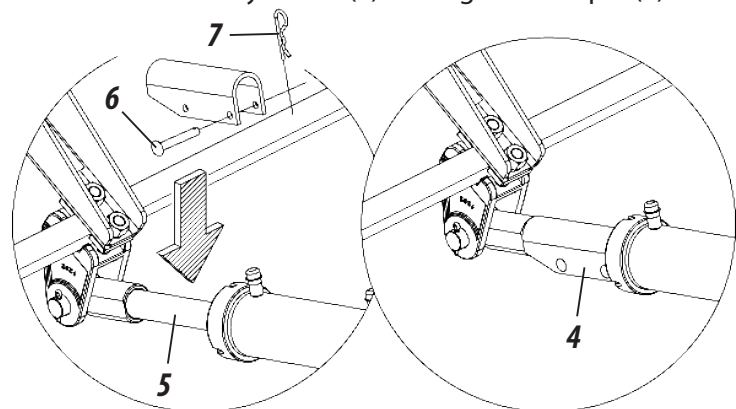

- 4- Before transporting the seeder, check that it is level with the ground, otherwise level it through the head regulator (10).

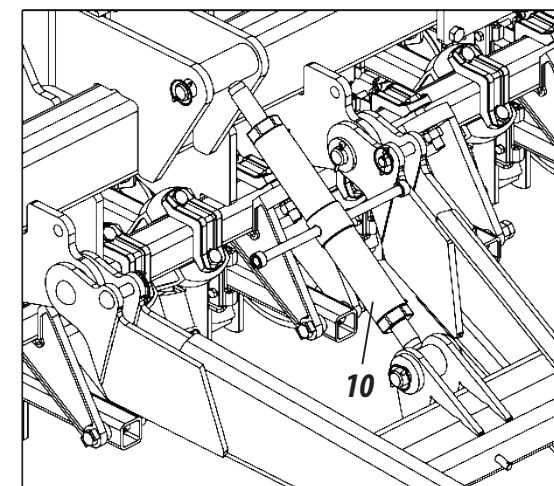

### ATENTION

**Do not transport the seeder without first checking all of the procedures mentioned.**

### PROCEDURE FOR WORK

Before working with the seeder, proceed as follows:

- 1- Bring the support bracket back (1) and secure with the pin (2) and lock (3).
- 2- With the seeder down, check that it is leveled relative to the ground, otherwise level it through the of the header regulator (4).

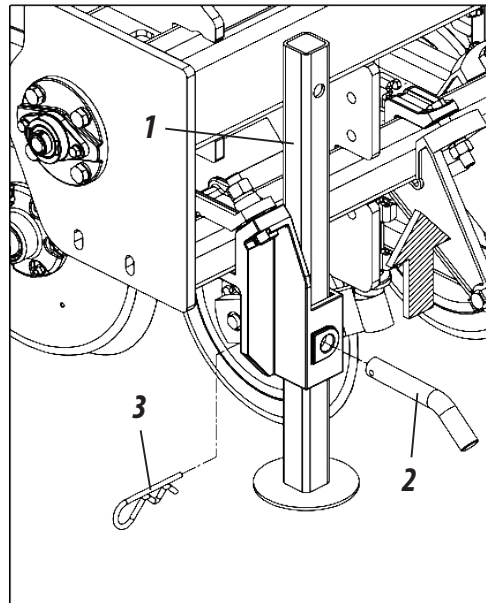

- 3- Then place the limiter (5) on the cylinders of the wheel (6), limiting the seeding of the seeder on the lines.

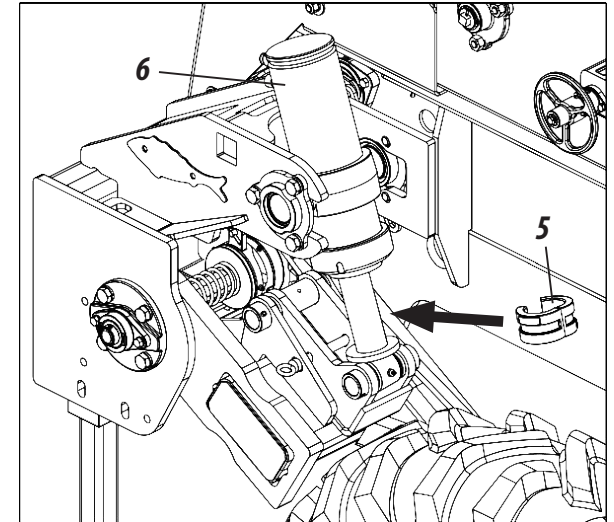

**⚠ ATTENTION** | *If necessary, also use the limiter (5) on the line cylinders (7) for depth limitation.*

### 🔍 IMPORTANT

*If necessary, also use the limiter (5) on the line cylinders (7) for depth 5 limitation.*

*If necessary, reduce or increase the spring pressure on the lines, depending on the type of ground, coverage and hardness of it.*

### 👉 NOTE

*To check the combinations and limiting ring models that accompany the seeder, refer to table on page 57.*

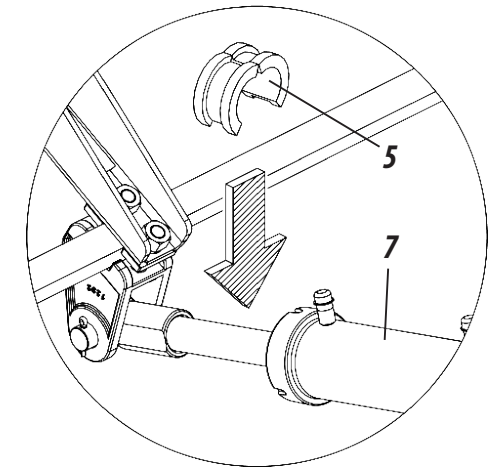
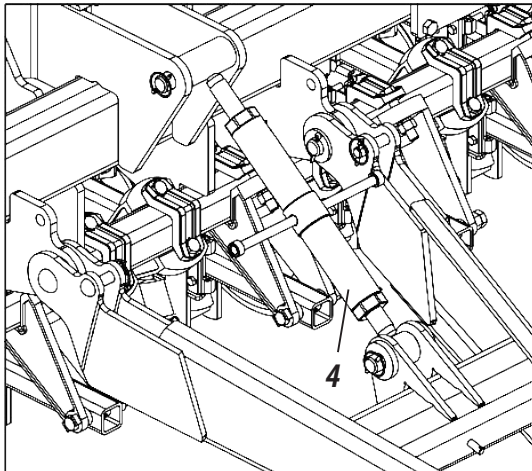

## WORK

# WORK / TRANSPORTATION

## FIXATION SYSTEM AND WHEEL ARTICULATION

The tire fixation and articulation system (1) makes them become free from the pressure of the springs on the ground, thereby allowing them to oscillate and follow the irregularities of the terrain, making so that the distribution of the fertilizer and seed is not disrupted.

1- For tires to oscillate, remove the pin (2) and lock (3) on both sides of the machine to free the system.

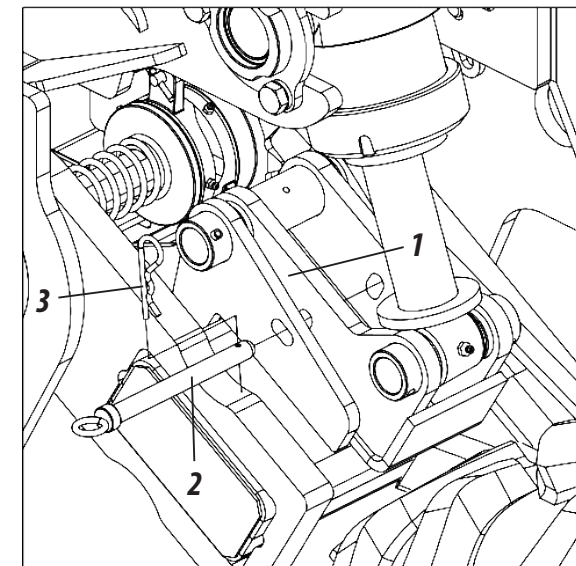

## ⚠️ ATTENTION

*To transport the seeder, insert the pin (2) and the latch (3).  
To work with the seeder, insert the pin (2) and the latch (3).*

## USE OF THE LADDER

The folding ladder (1) should be used only when supplying or servicing of tanks **SPDE CXP**. Before using the folding ladder (1), make sure the seeder is stopped and the tractor is switched off.

## ⚠️ ATTENTION

*Do not stand on the ladder when the seeder is working or being transported.  
Do not work or transport the seeder with the ladder open.  
Do not transport people on the platform, ladder or any other part of the seeder. Ignoring these warnings could result in serious injury or even death.*

## 🚫 IMPORTANT

*Always use the folding ladder (1) to access or fill the tank.  
The folding ladder (1) is in accordance with NBR standards.*

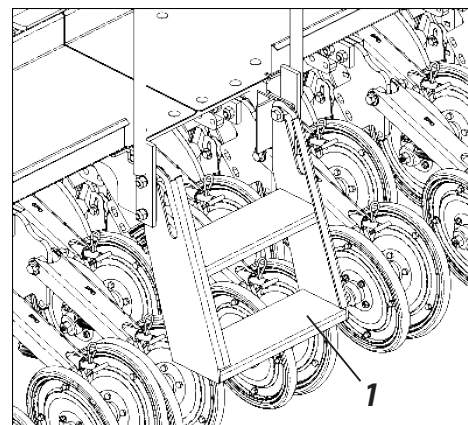

*Position for supply or maintenance of the tank*

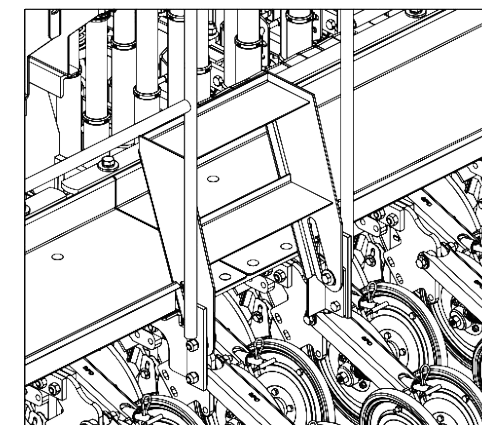

*Position for work or transport*

**SPACING BETWEEN LINES**

The seeder models **SPDE CXP** are provided with spacing of 170mm between lines for sowing of rice, wheat, oats and others, being able to make new spacings according to the type of cultivation desired.

**NUMBER OF EVEN LINES**

Mark the center of the **SPDE CXP** chassis and divide 1/2 (half) of the spacing to the left and 1/2 (half) to the right by fixing the first two lines at these points. Then, from these, assemble the other lines with the desired spacing.

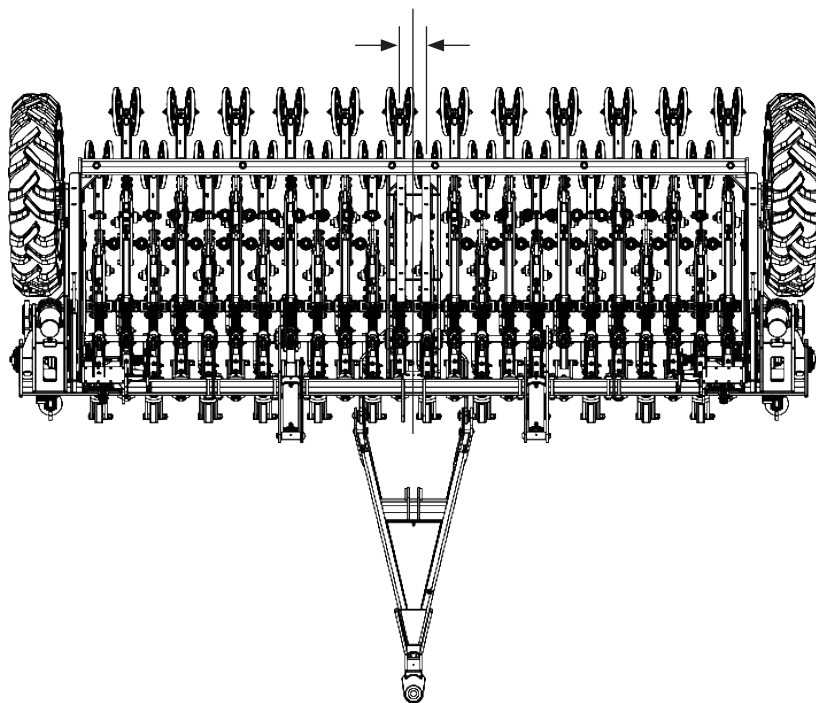

**NUMBER OF ODD LINES**

Attach a line to the center of the **SPDE CXP** and starting from it, assemble the others with lines of the desired spacing.

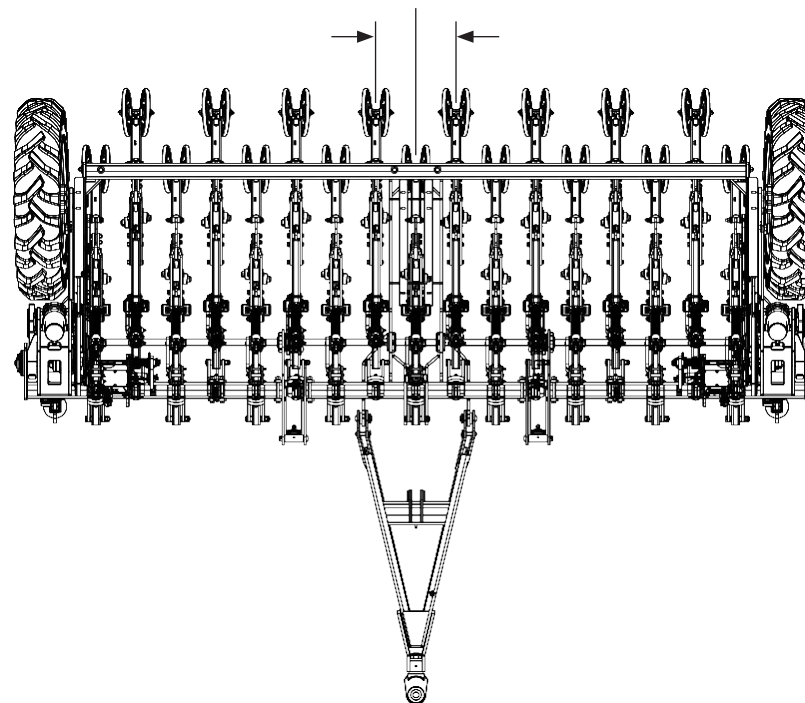

**NOTE**

*On the next page, check the possible spacings, observing the assembly instructions above, to assemble the number of odd or even lines.*



**ATTENTION**

*For larger spacing (soybean or others) if possible, use only parallel lines.*

**SPACING**

# SPACING

## SPACING TABLES IN MILLIMETERS

The seeder models **SPDE CXP** are provided with spacing of 170mm between lines for sowing of rice, wheat, oats and others, it is possible to make new spacings according to the type of crop desired.

<i>Model</i>	<i>Number of Lines</i>	<i>Spacing (mm)</i>	<i>Useful Width (mm)</i>
SPDE CXP 3000	3	1455	2550
	4	970	
	5	727	
	8	415	
	9	363	
	12	264	
	16	170	

<i>Model</i>	<i>Number of Lines</i>	<i>Spacing (mm)</i>	<i>Useful Width (mm)</i>
SPDE CXP 5000	4	1423	3910
	5	1067	
	6	854	
	7	712	
	9	534	
	12	388	
	13	356	
	15	305	
	17	267	
	24	170	

<i>Model</i>	<i>Number of Lines</i>	<i>Spacing (mm)</i>	<i>Useful Width (mm)</i>
SPDE CXP 4000	4	1196	3230
	5	897	
	7	598	
	10	398	
	14	276	
	17	224	
	20	170	

**NEW SPACINGS - PART I**

To make new line spacings on the **SPDE CXP** if necessary, remove some lines to increase spacing by doing the following:

- 1- Lift the seeder through the activation of the hydraulic cylinder (1).

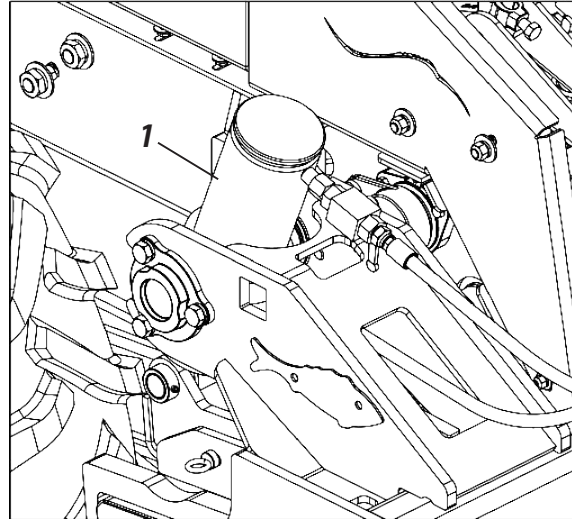

- 2- Then lower the support arms (2) and secure with the pin (3) and lock (4).

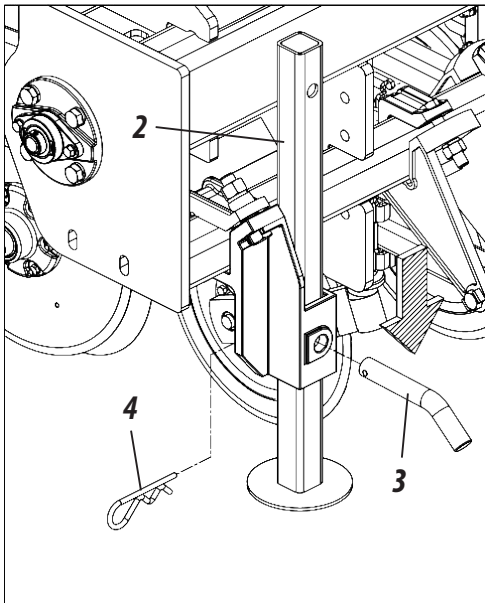

- 3- Remove the bolts (5), washers and nuts (6) from the spring rod holder, the fertilizer hose (7) and the seed hose (8). Then loosen the bolts (9), washers and nuts (10), remove the clamp (11) and the complete line (12) pulling it back.

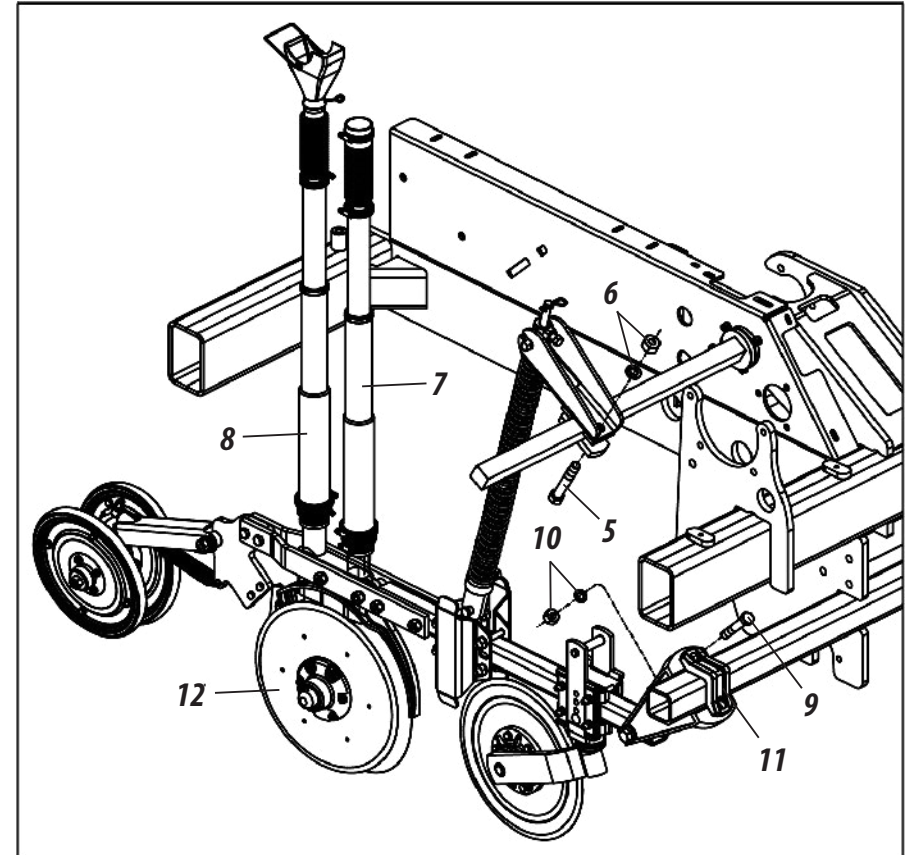
**! ATENTION**

*Before changing the line spacing, make sure the seeder is properly supported.*

**SPACING**

# SPACING

## NEW SPACINGS - PART II

- 4- Then close the fertilizer exits of the lines that will not be used, placing the covers (15) on the fertilizer conductors (14), locking them with the fasteners (16).
- 5- Then close the compost entrances inside the tank on the unused lines, placing the covers (17).
- 6- Finish by closing the seed outlets with the lid (18), moving it until the seed dispenser box (19) is fully closed.

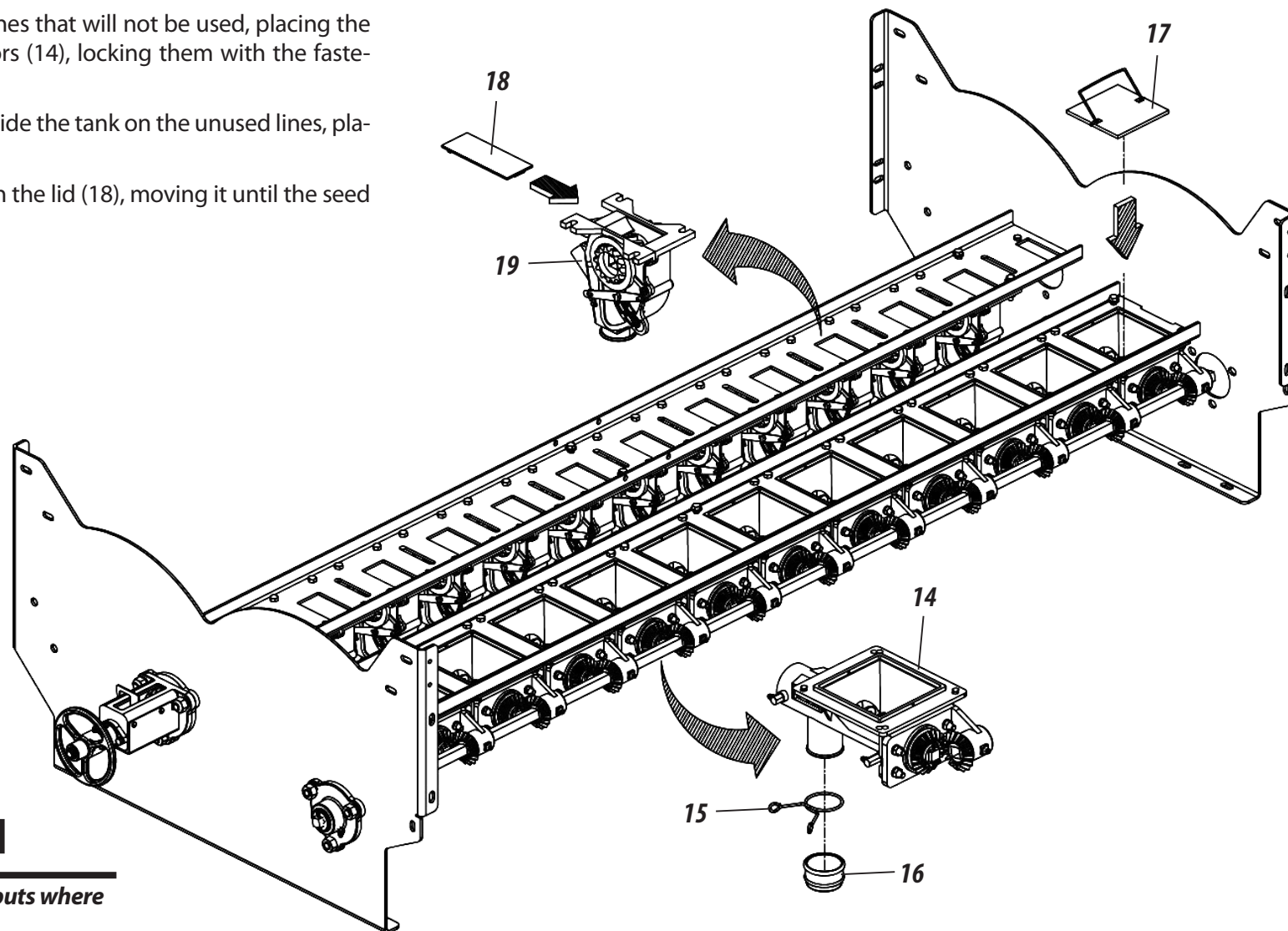

### ATTENTION

Repeat the above procedure on all outputs where lines will not be used.

#### ADJUSTING OF THE LINE MARKERS

The regulating of the line markers is important to obtain evenly spaced planting, making so that the edge line of the seeder is at the same spacing as the last planted line, facilitating future operations. To adjust the line markers, proceed as follows:

- 1- First of all, you must know the line spacing, the number of lines to be used in the operation and the tractor's front gauge. Use the formula below, followed by an example.

**EXAMPLE:** For planting with 17 rows in the seeder, with spacing of 0.26 m and the front gauge of the tractor at 1.43 m, determine:

Formula: 
$$D = \frac{E \times (N+1) - B}{2}$$

Solve: 
$$X = \frac{0,26 \times 18 - 1,43}{2}$$

$$D = 1,62 \text{ meters}$$

#### WHERE:

E = Spacing between lines (mts)  
 N = Number of lines  
 B = Tractor front gauge  
 D = Marker distance

#### NOTE

The line marker is used only when the seeder is equipped with the CPD Kit.

For fine grain cultivation, do not use the line markers.

- 2- Adjust the line marker disc with 1.62 mts to the center of the first planting line.
- 3- The line markers are sequential, one lowers after the other, so if during planting before the end of the line, there is a need to stop work, activate the valve of the line markers to continue working with the right side marker.

#### IMPORTANT

In case of tractor replacement, the calculation and adjustment must be done again.

In order for the line marker to return to the same side, it is necessary to actuate the valve twice.



#### ATTENTION

Avoid accidents caused by the intermittent action of the line markers. When operating the seeder, make sure there is nobody under the line markers or in their operating area.

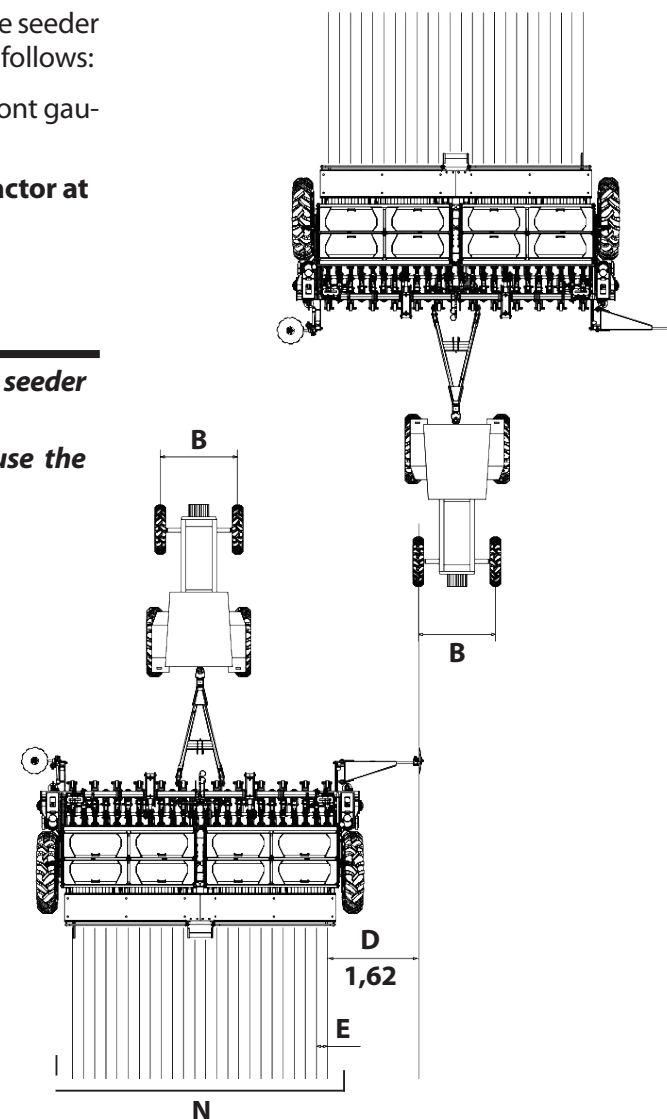

## ADJUSTMENTS

# ADJUSTMENTS

## ADJUSTING OF THE LINE MARKER DISCS

The discs (1) of the line markers (2) have angular adjustment to facilitate the demarcation work on the ground.

To adjust the discs (1) of the line markers (2), proceed as follows:

- 1- Loosen the nut (3), turn the disc (1) to the desired position.
- 2- Then retighten the nut (3), securing the disc (1) to the desired position.

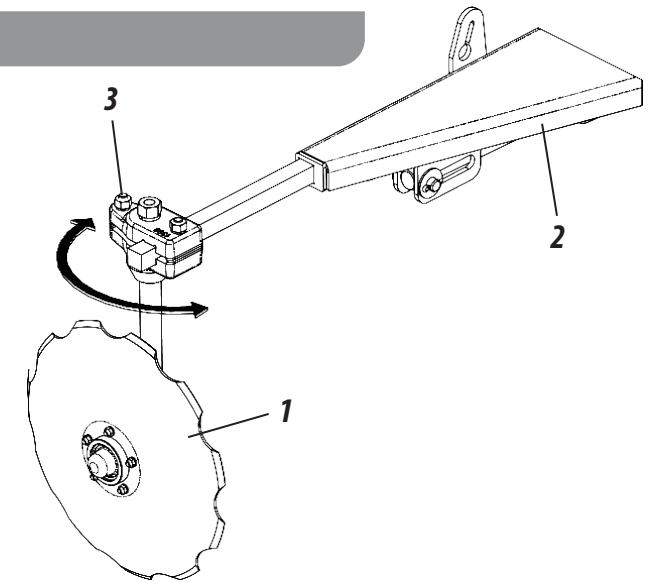

### ATTENTION

*Before making any adjustments to the line marker, make sure it is on the ground, the seeder is stopped and the tractor is off.*

## ADJUSTING OF THE LINE MARKER BAR

Line markers (1) have distance adjustment to be adjusted according to the number of lines, spacing and gauge of the tractor.

To adjust the distance of the line marker (1), proceed as follows:

- 1- Loosen the screw (2), move the rod (3) to the desired position.
- 2- Then retighten the bolt (2), securing the bar (3) to the desired position.

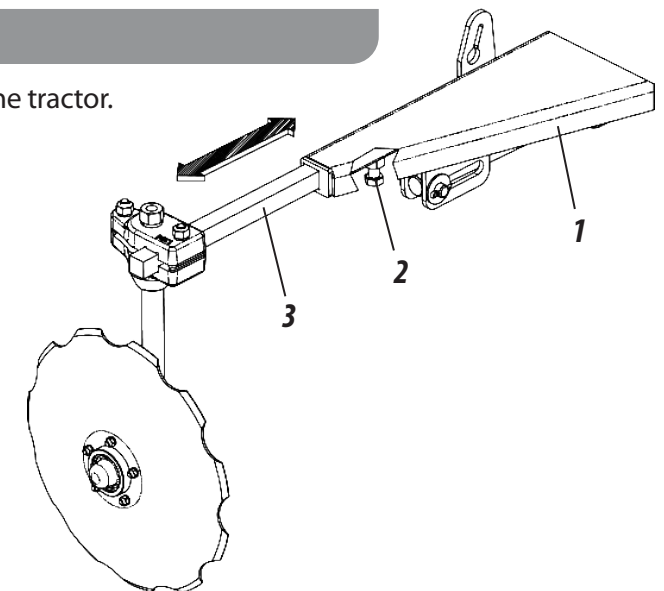

### IMPORTANT

*To know the distance to be regulated on the line marker, proceed as follows perform the calculation according to the instructions on the previous page.*

**FINISHING SYSTEM**

The **SPDE CXP** leaves the factory with the finishing system that allows planting with only one side of the seeder, that is, half of the lines. To activate the finishing system, proceed as follows:

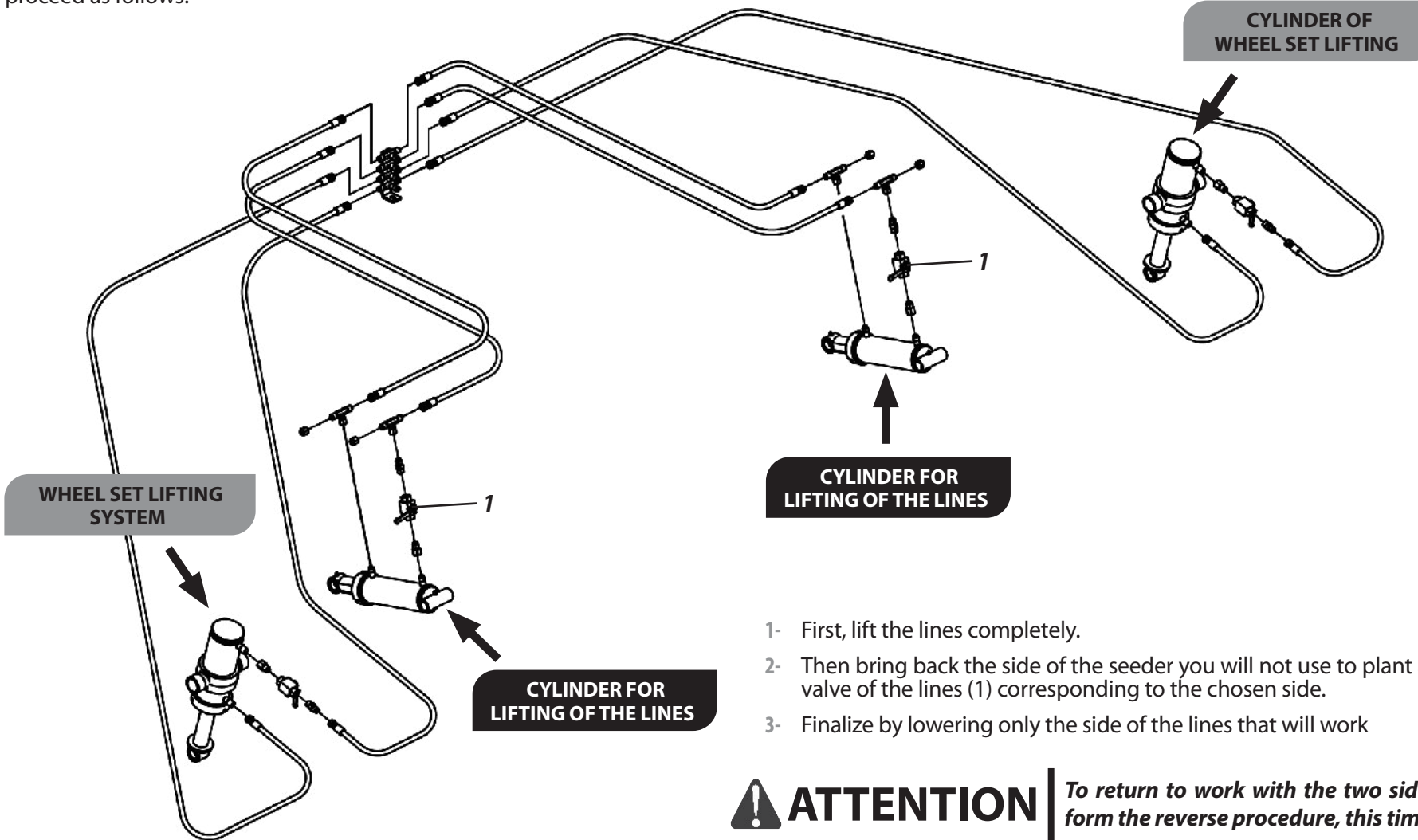

- 1- First, lift the lines completely.
- 2- Then bring back the side of the seeder you will not use to plant and close the pressure valve of the lines (1) corresponding to the chosen side.
- 3- Finalize by lowering only the side of the lines that will work

**! ATTENTION** | *To return to work with the two sides of the seeder, perform the reverse procedure, this time opening the valve.*

**ADJUSTMENTS**

# SEED DISTRIBUTION SYSTEM

## SEED REGULATION - PART I

The **SPDE CXP** Has seed dispensers (1), which have 03 (three) control points used according to the size of each type of seed to be used, being:

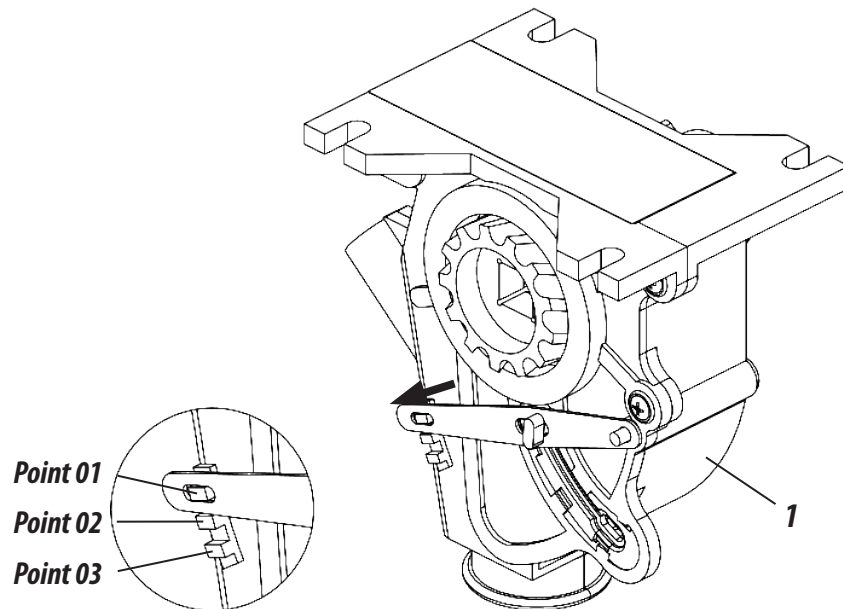

<b>Point 01 - For small seeds:</b>	Wheat, rice, oats and the like.
<b>Point 02 - For medium seeds:</b>	Soybean, rice, peas, etc.
<b>Point 03 - For large seeds:</b>	Soybean, etc.

### ATTENTION

*Failure to follow the above instructions may result in seed damage and/or changing of the quantity of seeds distributed.*

The distribution regulation of seeds is made through wheel valve (2), for this purpose, proceed as follows:

- 1- Pull the wheel valve (2) forward and unlocking it.

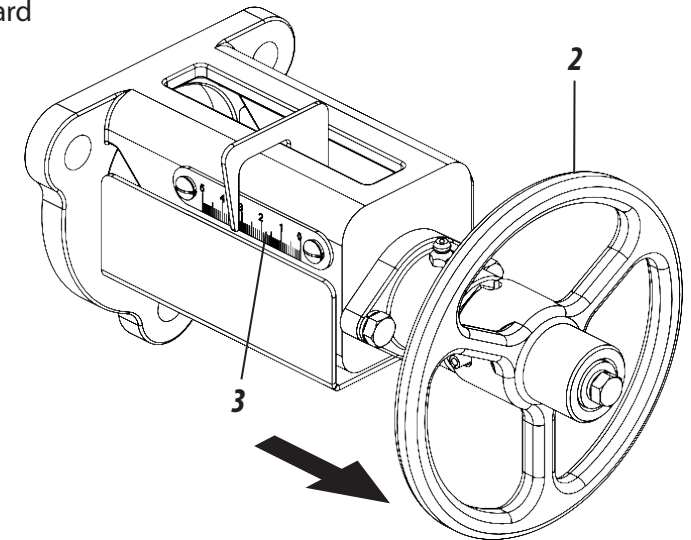

- 2- Then, turn the wheel valve (2) to the "A" or "B" direction by adjusting the doser (3) to the value found in the table on the following page, according to your needs and working condition.

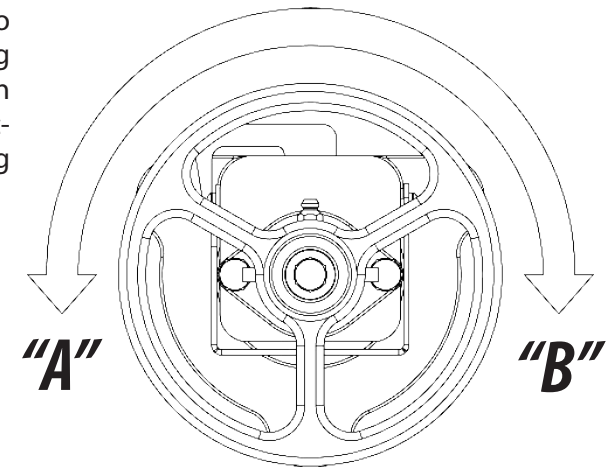

**SEED REGULATION - PART II**

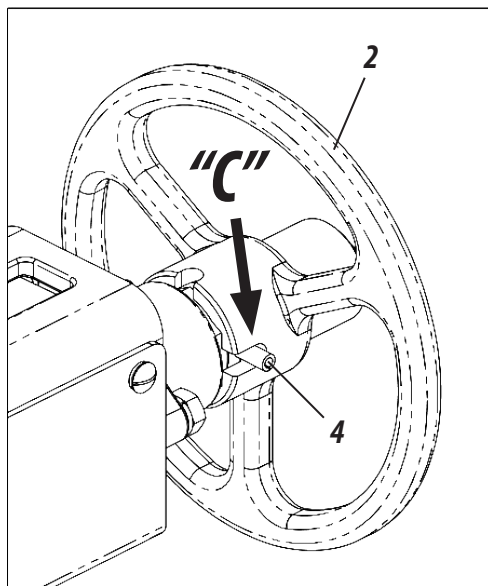
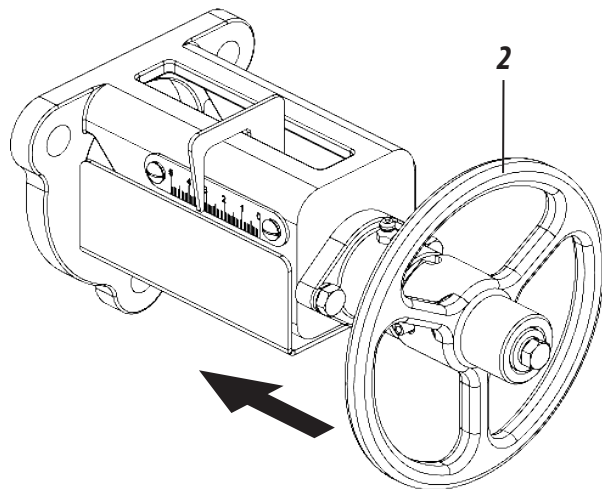

**ATTENTION**

To lock the wheel valve (2), the hole "C" must be positioned in the center of the spring pin (4).

**REGULATION FOR SEED DISTRIBUTION - PART I**

RESULTS IN GRAMS FOR LINES OF 50 MTS

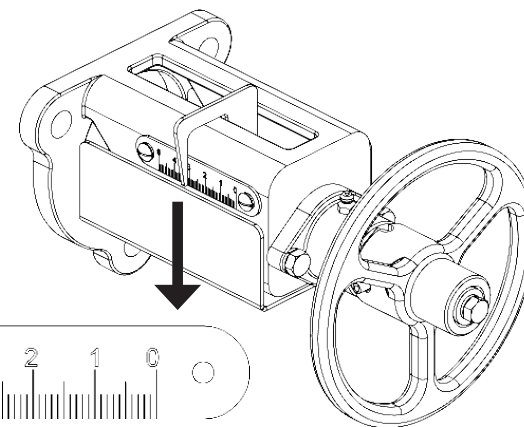

**SEED DOSING SCALE**

		Seed Regulation											
		0	5	10	15	20	25	30	35	40	45	50	
Seed distributor points	1	-	23	78	132	191	260	340	403	482	548	614	SOYBEAN
	2	-	31	101	161	233	303	400	487	573	654	733	
	3	-	39	117	191	270	355	459	512	656	756	843	
Seed distributor points	1	-	23	48	71	94	123	157	191	225	256	288	RICE
	2	-	28	57	84	113	145,5	183	220	257	292	326	
	3	-	30	61	95	123	160	204	246	289	330	368	
Seed distributor points	1	-	45	89	133	177	227	282	336	390	443	493	WHEAT
	2	-	50	101	152	203	263	333	402	471	537,5	600	
	3	5	67	133	200	266	329	390	449	510,5	570	632	

**SEED DISTRIBUTION SYSTEM**

# SEED DISTRIBUTION SYSTEM

## REGULATION FOR SEED DISTRIBUTION PART II

### SEED DISTRIBUTOR

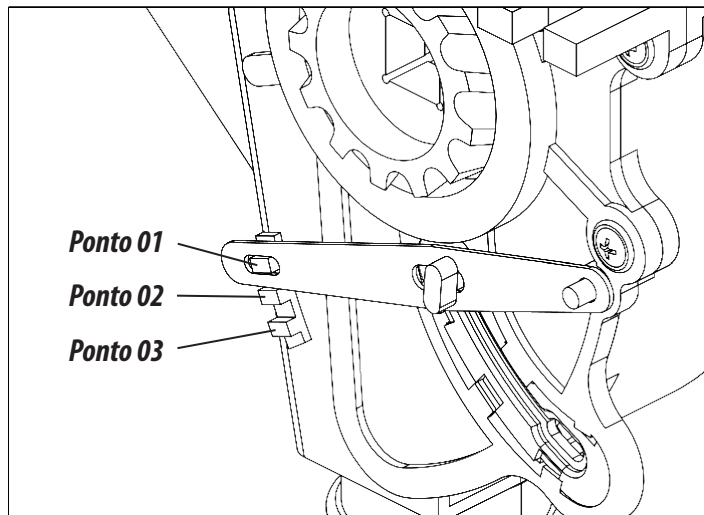

Ha = 10.000 m<sup>2</sup>

AA = 24.200 m<sup>2</sup>

## ATTENTION

*Before beginning sowing, check that the distribution is correct in relation to the distribution table of the previous page.*

## TO CALCULATE THE AMOUNT OF FERTILIZER AND SEED PER HA OR AA, ONE SHOULD:

- 1- Be aware of the amount of fertilizer and seed to be applied per (Ha) or (AA).
- 2- Be aware of the row spacing of the seeder.
- 3- Perform the calculation by Ha, dividing the Ha = 10,000 m<sup>2</sup> by the spacing to be planted.
- 4- If the calculation is done by AA, divide the AA = 24,200 m<sup>2</sup> by the spacing to be planted.
- 5- And finally, divide the amount of fertilizer and seed to be applied by the linear meters.
- 6- To gauge the weight, collect the fertilizer or seeds in 10 or more meters rotated to do the weighing.

#### REGULATION OF THE FINE SEED BOX (PASTURE) - OPTIONAL

The **SPDE CXP** can be purchased optionally with a tank for fine seeds (pasture). To regulate the fine seed box (pasture), proceed as follows:

- 1- Refer to the distribution table below and check the desired quantity per hectare.
- 2- Then unlock the wheel valve (1) through the lock (2).
- 3- Then, turn the wheel valve (1) to the "A" or "B" direction, adjusting scale (3) to the value found in the table according to your needs and working condition 4.0 work.

The distribution of pasture seeds (kg / ha) with spacing of 170 mm									
		Scale number							
GRASSES	Type of Culture	0,5	1,0	1,5	2,0	2,5	3,0	3,5	4,0
	COLONIÃO	-	2,0	3,5	5,0	9,0	10,0	10,0	11,0
	COMMON COMUM	-	5,0	7,0	10,0	17,0	20,0	20,0	22,0
	BRACHIARA BRIZANTHA	-	3,0	5,0	7,0	14,0	17,0	17,0	20,0
	PAINÇO	3,0	8,0	14,0	20,0	32,0	40,0	40,0	48,0
LEGUMES	SOY PERENE	3,5	10,0	17,0	24,0	32,0	41,0	50,0	59,0
	ALFAFA	4,0	12,0	20,0	29,0	38,0	47,0	56,0	65,0
	CORNICHÃO	4,5	13,0	21,0	30,0	40,0	50,0	60,0	70,0
	DESMODIUM	3,8	12,0	19,0	26,0	34,0	43,0	52,0	61,0
	CLOVER	3,6	11,0	18,0	25,0	33,0	42,0	51,0	60,0

#### EXAMPLE:

To distribute 10kg / ha of coloniã seeds with a spacing of 170mm, turn the wheel valve (1) until the regulator reaches the number 3.5 of the scale (3), as shown in the figure on the side.

#### ATTENTION

The table of distribution of pasture seeds above presents approximate values per hectare for spacing of 170 mm. This table may vary according to the types of seed varieties. We recommend doing a practical check before you start planting.

#### Turning the wheel in the "A" direction

The scale is closed.

#### Turning the steering wheel in the "B" direction

Scale opens.

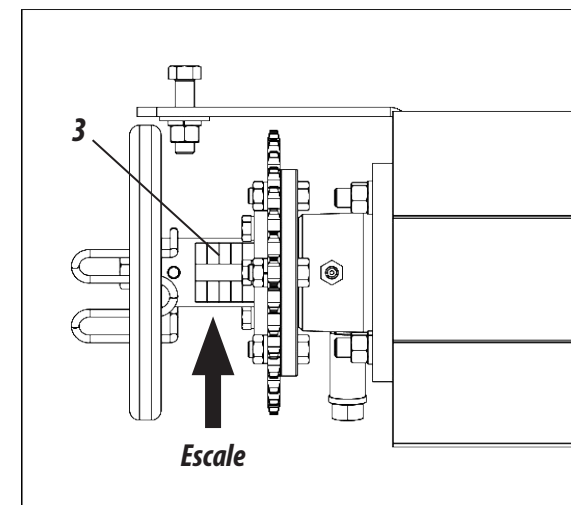
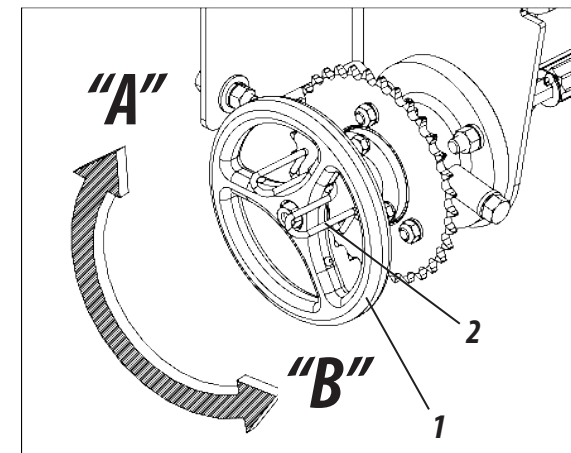

# SEED DISTRIBUTION SYSTEM

## INDEPENDENT FERTILIZER DISTRIBUTION SYSTEM

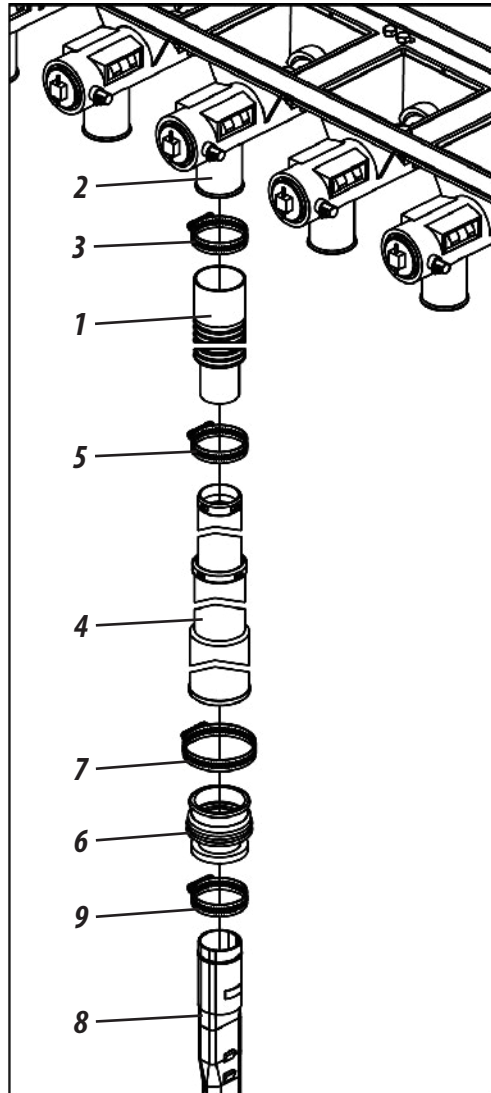

To send the fertilizer from the distributor to the ground, fit the hose (1) to the outputs of the independent conductor (2) through the clips (3). Then, attach the telescopic cable (4) to the hose (1) by attaching it through the clamp (5). Then, attach the rubber coupling (6) to the telescopic cable (4) by attaching it through the clip (7). Finish by attaching the spout (8) to the rubber coupling (6) by attaching through the clip (9).

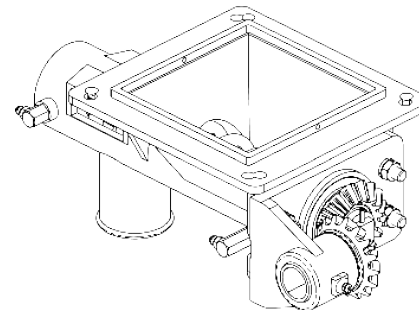

INDEPENDENT CONDUCTOR

### ATTENTION

*Check dispensers and hoses daily and clean the exits. When the fertilizer has impurities or is moist, clean it more often.*

The independent distribution system has safety outputs that ensure the smooth operation of the system without damaging it. In the event of clogging of the hose and the doser, clean the doser up to the end of the hose near the double disc, as the system can clog up with roots, pieces of plastic and other objects.

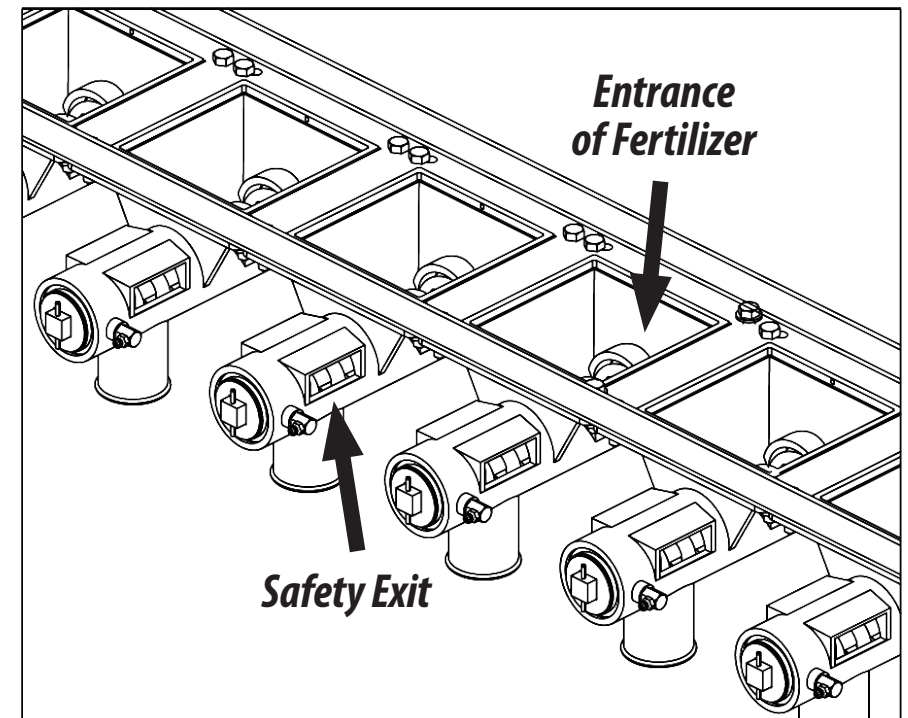

**FERTISYSTEM FERTILIZER DISTRIBUTION SYSTEM - OPTIONAL (FIGURES 49/50)**

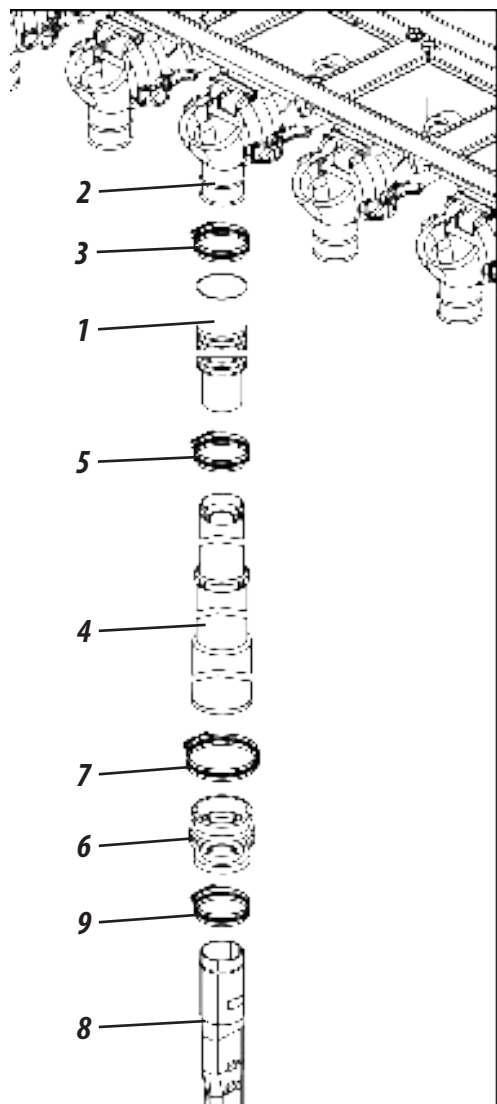

To send the fertilizer from the distributor to the ground, fit the hose (1) to the outputs of the independent conductor (2) through the clips (3). Then, attach the telescopic cable (4) to the hose (1) by attaching it through the clamp (5). Then, attach the rubber coupling (6) to the telescopic cable (4) by attaching it through the clip (7). Finish by attaching the spout (8) to the rubber coupling (6) by attaching through the clip (9).

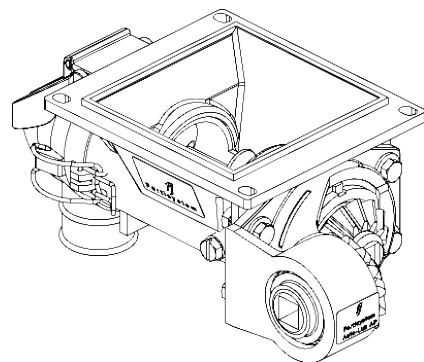

**FERTISYSTEM CONDUCTOR**

**! ATTENTION**

*Check dispensers and hoses daily and clean the exits. When the fertilizer has impurities or is moist, clean it more often.*

The Fertisystem distribution system has safety outputs that ensure the smooth operation of the system without damaging it. In the event of clogging of the hose and the doser, clean the doser up to the end of the hose near the double disc, as the system can clog up with roots, pieces of plastic and other objects.

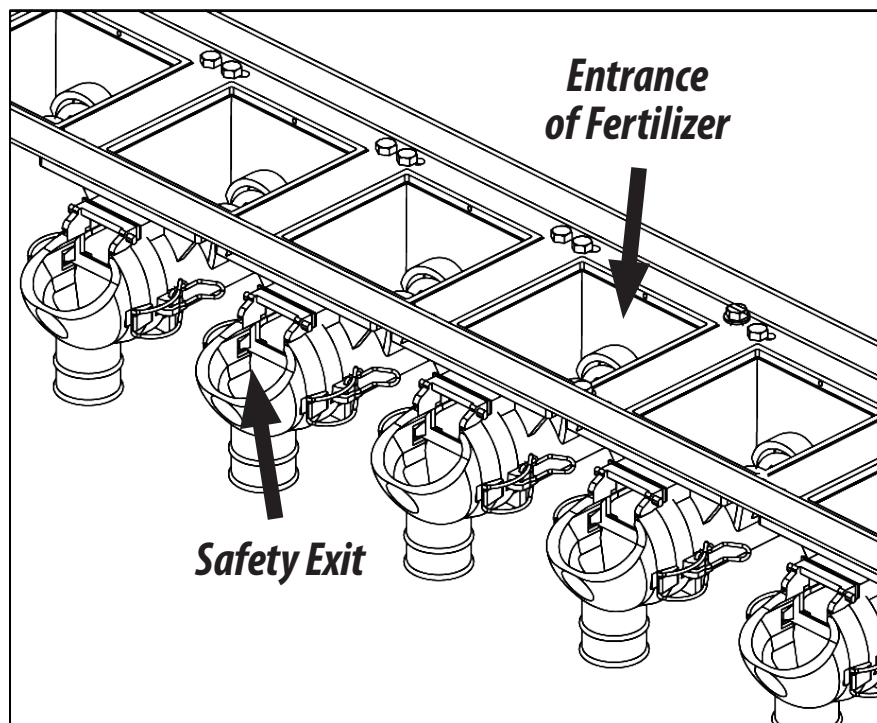

**FERTILIZER DISTRIBUTION SYSTEM**

# FERTILIZER DISTRIBUTION SYSTEM

## SPEED BOX

The seeders are equipped with the *Speed Box* (1), system, which drives the distribution system with simple adjustments, ensuring fast rotation changes. To regulate seeds, proceed as follows:

- 1- Select the desired quantity in the tables and check the corresponding combination on the levers (2). **Example:** Position **F2** In the table, indicates that the lever with letters should be in position "F" and the lever with numbers must be in position "2".
- 2- To move the levers, remove the lock (3), pull the handle (4), then adjust the levers as shown above. At the end of the combination, return the knob (4) and replace the lock (3).

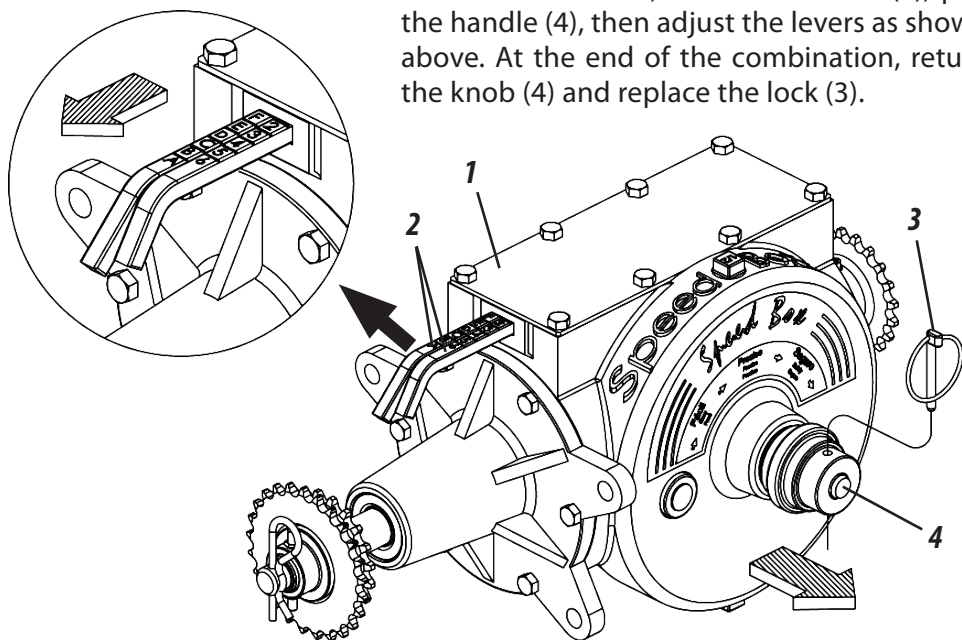

**IMPORTANT** After changing the gears, check the chain tension. The tensioner (2) is provided with a torsion spring (4) for greater flexibility of it. If more pressure is required on the tensioner, proceed as instructed on page 67.

## REGULATION FOR FERTILIZER DISTRIBUTION

The seed adjustment is made by the *Speed Box* (1). For more adjustments, reverse the direction of chain of the motor gears. "A" and moved "B". To reverse the direction of the chain on the gears, proceed as follows:

- 1- First, turn the tensioner (2) removing the tension of the chain (3).
- 2- Then reverse the chain (3) as work requires.
- 3- Then, release the tensioner (2) releasing it, returning the tension in the chain (3).

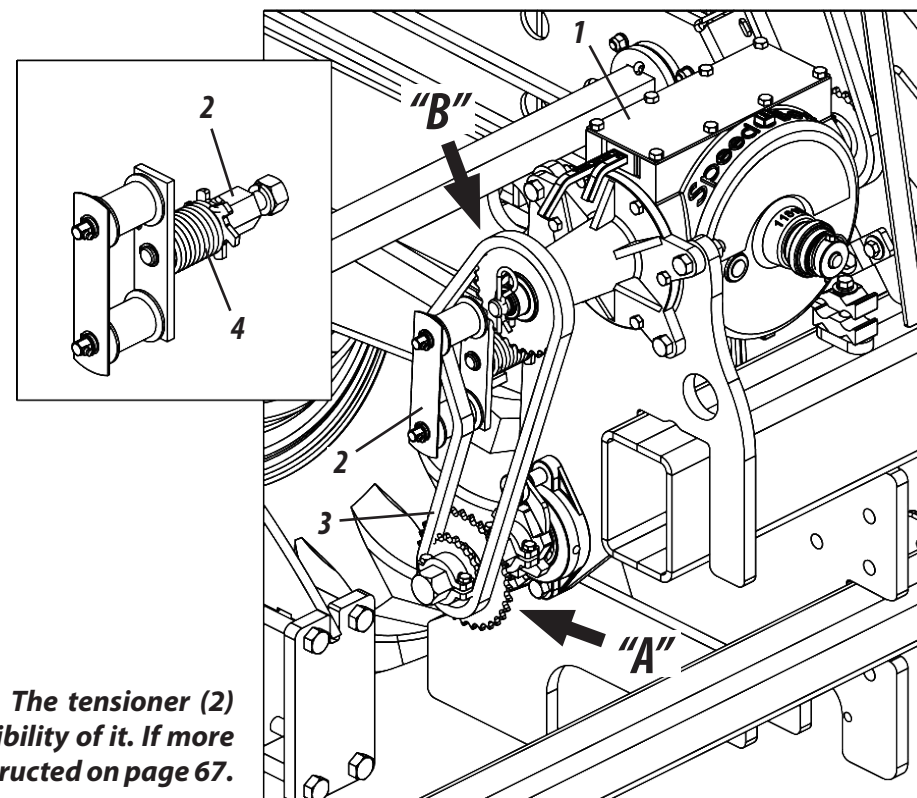

Fertilizer Distribution Table per hectare - SPDE CXP

Ratchet shaft output gear		Input gear of Speed Box													
		20							31						
Combination	Grams 50 m linear	Line Spacing													
		170	250	300	350	400	450	500	550	600	650	700	750	800	850
F - 1	85	100	68	57	48	42	38	34	31	28	26	24	23	21	20
F - 2	95	112	76	64	55	48	42	38	35	32	29	27	25	24	22
E - 1	106	125	85	71	61	53	47	42	39	35	33	30	28	27	25
F - 3	109	128	87	73	62	55	48	44	40	36	34	31	29	27	26
E - 2	119	140	95	80	68	60	53	48	43	40	37	34	32	30	28
D - 1	127	150	102	85	73	64	57	51	46	42	39	36	34	32	30
F - 4	127	150	102	85	73	64	57	51	46	42	39	36	34	32	30
E - 3	136	160	109	91	78	68	61	55	50	45	42	39	36	34	32
D - 2	143	168	115	95	82	72	64	57	52	48	44	41	38	36	34
C - 1	148	175	119	99	85	74	66	59	54	49	46	42	40	37	35
F - 5	153	180	122	102	87	76	68	61	56	51	47	44	41	38	36
E - 4	159	187	127	106	91	80	71	64	58	53	49	45	42	40	37
D - 3	164	192	131	109	93	82	73	65	59	55	50	47	44	41	38
C - 2	167	196	134	111	95	83	74	67	61	56	51	48	45	42	39
B - 1	170	200	136	113	97	85	75	68	62	57	52	48	45	42	40
A - 1	191	225	153	127	109	95	85	76	69	64	59	55	51	48	45
A - 2	215	253	172	143	123	107	95	86	78	72	66	61	57	54	51
B - 3	218	257	174	145	125	109	97	87	79	73	67	62	58	55	51
C - 4	223	262	178	148	127	111	99	89	81	74	69	64	59	56	52
D - 5	229	269	183	153	131	115	102	92	83	76	70	65	61	57	54
E - 6	239	281	191	159	136	119	106	95	87	80	73	68	64	60	56
A - 3	245	289	196	164	140	123	109	98	89	82	76	70	65	61	58
B - 4	254	299	204	170	145	127	113	102	93	85	78	73	68	64	60
C - 5	267	314	214	178	153	134	119	107	97	89	82	76	71	67	63
D - 6	286	337	229	191	164	143	127	115	104	95	88	82	76	72	67
A - 4	286	337	229	191	164	143	127	115	104	95	88	82	76	72	67
B - 5	305	359	244	204	174	153	136	122	111	102	94	87	81	76	72
C - 6	334	393	267	223	191	167	148	134	121	111	103	95	89	83	79
A - 5	344	404	275	229	196	172	153	137	125	115	106	98	92	86	81
B - 6	382	449	305	254	218	191	170	153	139	127	117	109	102	95	90
A - 6	429	505	344	286	245	215	191	172	156	143	132	123	115	107	101

Note: Spring with 1" pitch

## FERTILIZER DISTRIBUTION SYSTEM

# FERTILIZER DISTRIBUTION SYSTEM

Note: Spring with 1" pitch

Fertilizer Distribution Table per hectare - SPDE CXP

Ratchet shaft output gear				31				Input gear of the Speed Box								20	
Motor / Sprocket	Motor / Driven	Combination	Grams 50 m linear	Line Spacing													
				170	250	300	350	400	450	500	550	600	650	700	750	800	850
54	24	F - 1	204	240	163	136	116	102	91	82	74	68	63	58	54	51	48
48	24	F - 2	229	270	183	153	131	115	102	92	83	76	71	66	61	57	54
54	30	E - 1	255	300	204	170	146	127	113	102	93	85	78	73	68	64	60
42	24	F - 3	262	308	210	175	150	131	116	105	95	87	81	75	70	66	62
48	30	E - 2	287	337	229	191	164	143	127	115	104	96	88	82	76	72	67
54	36	D - 1	306	360	245	204	175	153	136	122	111	102	94	87	82	76	72
36	24	F - 4	306	360	245	204	175	153	136	122	111	102	94	87	82	76	72
42	30	E - 3	328	385	262	218	187	164	146	131	119	109	101	94	87	82	77
48	36	D - 2	344	405	275	229	197	172	153	138	125	115	106	98	92	86	81
54	42	C - 1	357	420	285	238	204	178	159	143	130	119	110	102	95	89	84
30	24	F - 5	367	432	293	245	210	183	163	147	133	122	113	105	98	92	86
36	30	E - 4	382	450	306	255	218	191	170	153	139	127	118	109	102	96	90
42	36	D - 3	393	462	314	262	225	197	175	157	143	131	121	112	105	98	92
48	42	C - 2	401	472	321	267	229	201	178	160	146	134	123	115	107	100	94
54	48	B - 1	408	480	326	272	233	204	181	163	148	136	125	116	109	102	96
54	54	A - 1	459	539	367	306	262	229	204	183	167	153	141	131	122	115	108
48	54	A - 2	516	607	413	344	295	258	229	206	188	172	159	147	138	129	121
42	48	B - 3	524	617	419	349	299	262	233	210	191	175	161	150	140	131	123
36	42	C - 4	535	629	428	357	306	267	238	214	195	178	165	153	143	134	126
30	36	D - 5	550	647	440	367	314	275	245	220	200	183	169	157	147	138	129
24	30	E - 6	573	674	459	382	328	287	255	229	208	191	176	164	153	143	135
42	54	A - 3	590	694	472	393	337	295	262	236	214	197	181	168	157	147	139
36	48	B - 4	611	719	489	408	349	306	272	245	222	204	188	175	163	153	144
30	42	C - 5	642	755	514	428	367	321	285	257	233	214	198	183	171	160	151
24	36	D - 6	688	809	550	459	393	344	306	275	250	229	212	197	183	172	162
36	54	A - 4	688	809	550	459	393	344	306	275	250	229	212	197	183	172	162
30	48	B - 5	734	863	587	489	419	367	326	293	267	245	226	210	196	183	173
24	42	C - 6	802	944	642	535	459	401	357	321	292	267	247	229	214	201	189
30	54	A - 5	825	971	660	550	472	413	367	330	300	275	254	236	220	206	194
24	48	B - 6	917	1079	734	611	524	459	408	367	333	306	282	262	245	229	216
24	54	A - 6	1032	1214	825	688	590	516	459	413	375	344	317	295	275	258	243

**NOTE**

The fertilizer tables on pages 44 and 45 were calculated with a 1" pitch spring. Optionally, there are other types of spring that can increase (2" pitch spring) or decrease the fertilizer distribution (3/4" and 5/8" pitch springs).

CONVERSION OF THE DISTRIBUTION SPRINGS - TABLE 20/31				
EXAMPLES:				
Springs	Spacing	Regulation	Percentage	Kg por Ha
Pitch 2"	170 mm	F-1	-	160
Pitch 1"		F-1	- 60 %	100
Pitch 3/4"		F-1	- 60 %	40
Pitch 5/8"		F-1	- 60 %	16

CONVERSION OF THE DISTRIBUTION SPRINGS - TABLE 31/20				
EXAMPLES:				
Springs	Spacing	Regulation	Percentage	Kg por Ha
Pitch 2"	170 mm	F-1	-	384
Pitch 1"		F-1	- 60 %	204
Pitch 3/4"		F-1	- 60 %	81,6
Pitch 5/8"		F-1	- 60 %	32,64

**ATTENTION**

The tables above were prepared for distribution with springs de of different pitches with fertilizer (N.P.K) of a good particle size and with a hectoliter weight of 1200 grams per liter.

**CALCULATION**

**PRACTICAL CALCULATION FOR FERTILIZER DISTRIBUTION**

To distribute other quantities of fertilizer in spacings and areas other than those shown in the distribution tables, use the formula below to proceed as such:

- 1- Determine the spacing and the amount of fertiliser to be distributed by Bushel (Aa) or Hectare (Ha).
- 2- **Example:** Seeder with spacing of 170 mm, to distribute 500 kg of fertilizer per Ha, use the formula below:

Formula: 
$$X = \frac{E \times Q}{A} \times D$$

**Formula Data:**

- E** = Line Spacing (mm)  $X = 85.00 \times 50 = 4,250$
- Q** = Amount of fertilizer to be distributed [kg]
- A** = Area to be fertilized [m<sup>2</sup>]
- D** = Distance of 50 meters (test)
- X** = Grams of fertilizer in 50 meters

Solve: 
$$X = \frac{170 \times 500}{10.000} \times 50$$
  

$$X = 85,00 \times 50 = 4,250$$
  
**X = 4,250 grams in 50 meters per line.**

**NOTE**

When you get the result, adjust the seeder to distribute the amount found, or the one that comes closest to the predetermined space for the test.

**ATTENTION**

The variation in the speed of work affects the uniform distribution of the seeds .When exchanging the seed batch or the manufacturer of the fertilizer, it is necessary to check again. After the first day of planting, check all adjustments again.

# CALCULATION

## PRACTICAL TEST TO ASSESS THE QUANTITY OF FERTILISER AND SEED DISTRIBUTION.

- 1- For greater precision in the distribution of fertilizer or seeds, test the quantity to be distributed at the planting site, because for each ground there is a different condition. Proceed as follows:
- 2- As far as possible, always use the same tractor and operator who will plant.
- 3- Always check and maintain the correct tire pressure calibration **SPDE CXP** Which should be at **24 lb / in<sup>2</sup>**.
- 4- Note the distance of the test in the table, we opted for 50 linear meters.
- 5- Fill the tanks of the seeder at least halfway. Run an average of 10 meters outside the test area so that the fertilizer and seeds fill the dosers.
- 6- Seal the output of seed spouts and place containers to collect the outputs of fertilizer. Move the tractor in the demarcated area, always at the same speed you will plant, from 5 to 7 km/h.
- 7- After traversing the demarcated space, remove the seal from the seed spout and collect the seeds for counting and also collect the fertilizer to weigh the amount collected. If necessary, increase or decrease the amount of seed and fertilizer to be distributed, check the table.
- 8- When you reach the desired amount, still in the area, move the tractor at the same speed, however, letting the fertilizer and seed reach the soil to check for the uniformity of the distribution.



### IMPORTANT

*We suggest that a practical test be carried out on the distribution of the fertilizer and seed, over 50 mts, to later compare the results of the fertilizer and the seed.*

**OPTIONAL LINE MODELS**

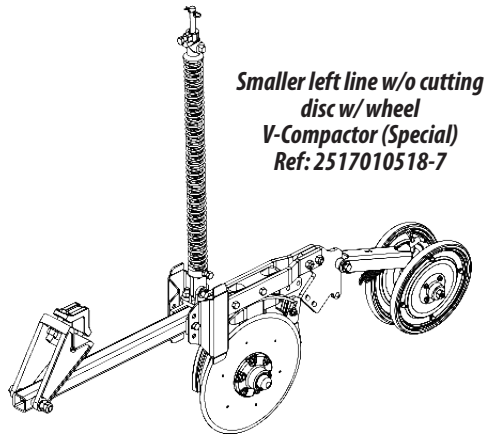

*Smaller left line w/o cutting disc w/ wheel  
V-Compactor (Special)  
Ref: 2517010518-7*

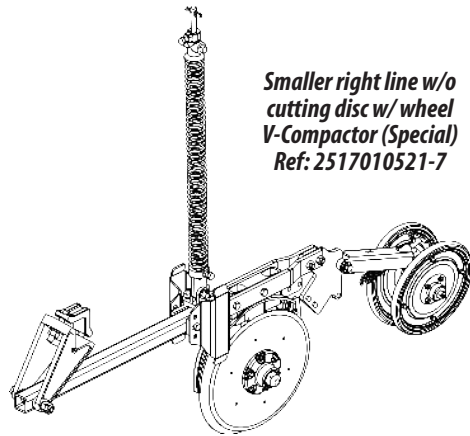

*Smaller right line w/o cutting disc w/ wheel  
V-Compactor (Special)  
Ref: 2517010521-7*

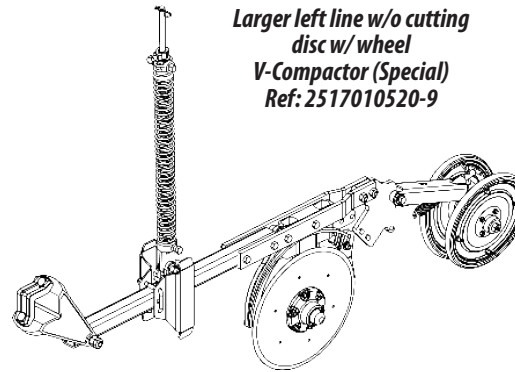

*Larger left line w/o cutting disc w/ wheel  
V-Compactor (Special)  
Ref: 2517010520-9*

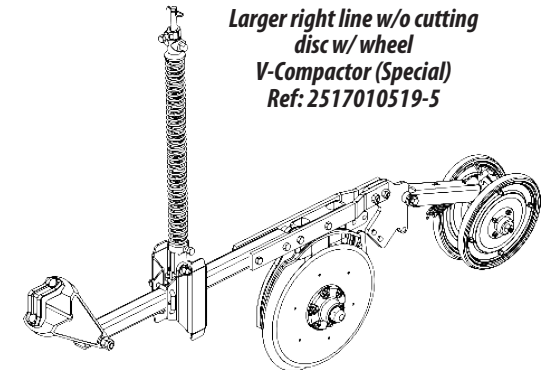

*Larger right line w/o cutting disc w/ wheel  
V-Compactor (Special)  
Ref: 2517010519-5*

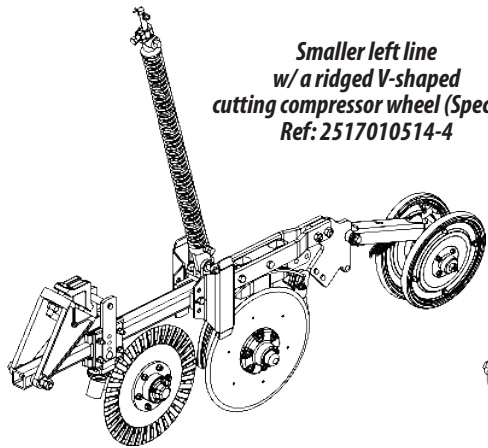

*Smaller left line w/ a ridged V-shaped cutting compressor wheel (Special)  
Ref: 2517010514-4*

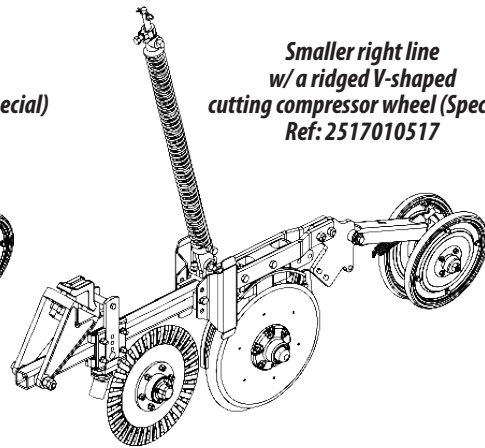

*Smaller right line w/ a ridged V-shaped cutting compressor wheel (Special)  
Ref: 2517010517*

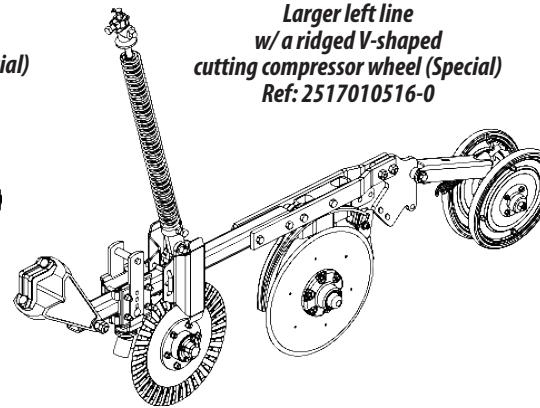

*Larger left line w/ a ridged V-shaped cutting compressor wheel (Special)  
Ref: 2517010516-0*

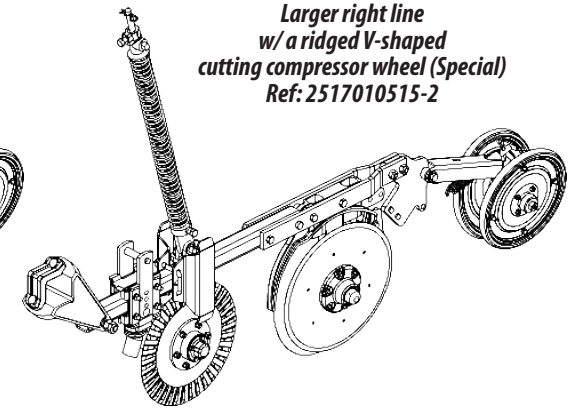

*Larger right line w/ a ridged V-shaped cutting compressor wheel (Special)  
Ref: 2517010515-2*

**PLANTING LINES**

# PLANTING LINES

## OPTIONAL LINE MODELS - CONTINUATION

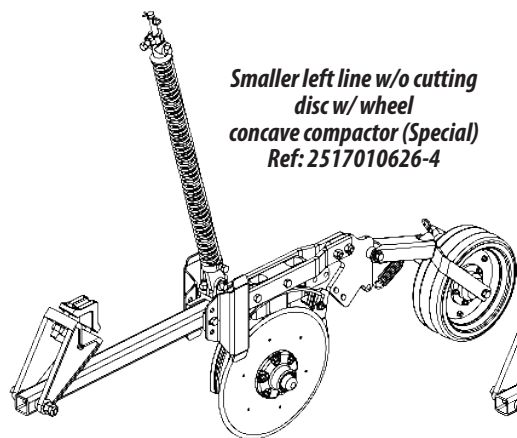

*Smaller left line w/o cutting disc w/ wheel concave compactor (Special)  
Ref: 2517010626-4*

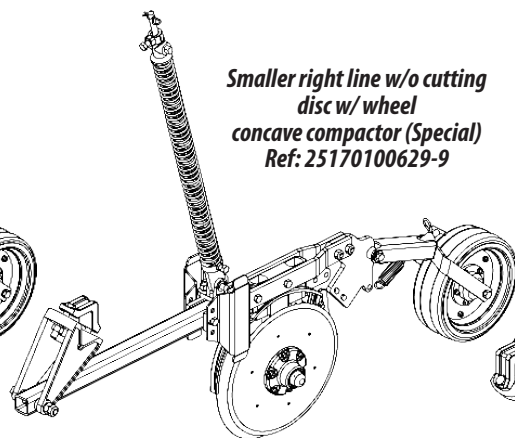

*Smaller right line w/o cutting disc w/ wheel concave compactor (Special)  
Ref: 2517010629-9*

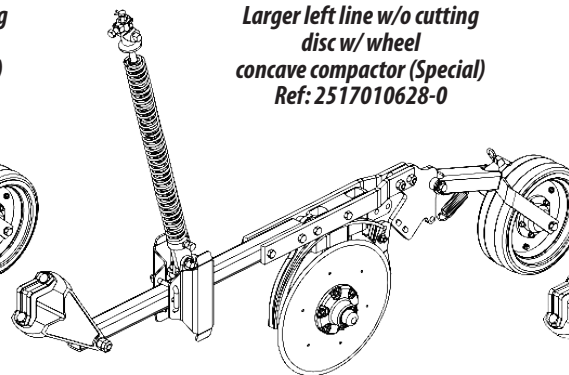

*Larger left line w/o cutting disc w/ wheel concave compactor (Special)  
Ref: 2517010628-0*

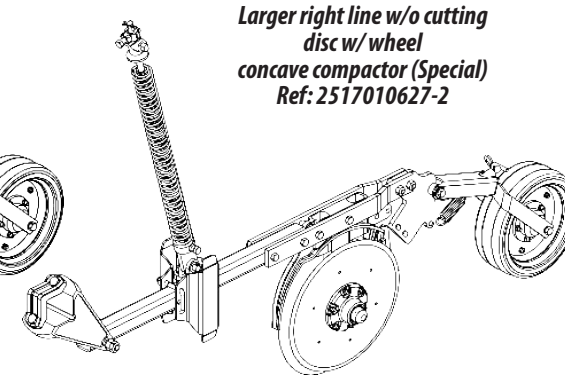

*Larger right line w/o cutting disc w/ wheel concave compactor (Special)  
Ref: 2517010627-2*

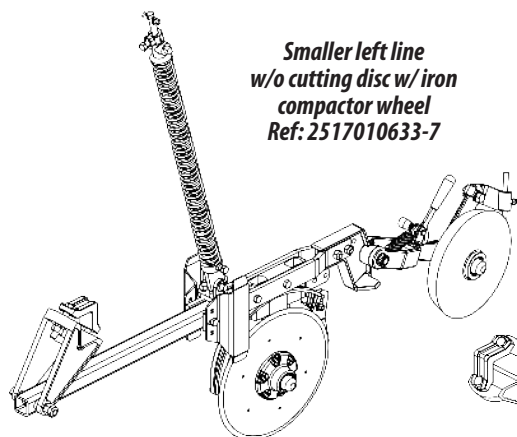

*Smaller left line w/o cutting disc w/ iron compactor wheel  
Ref: 2517010633-7*

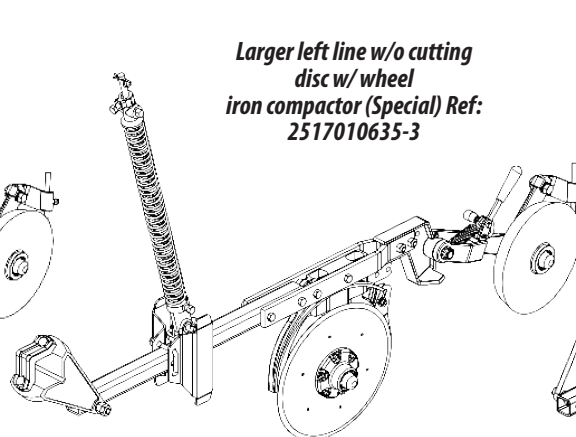

*Larger left line w/o cutting disc w/ wheel iron compactor (Special) Ref: 2517010635-3*

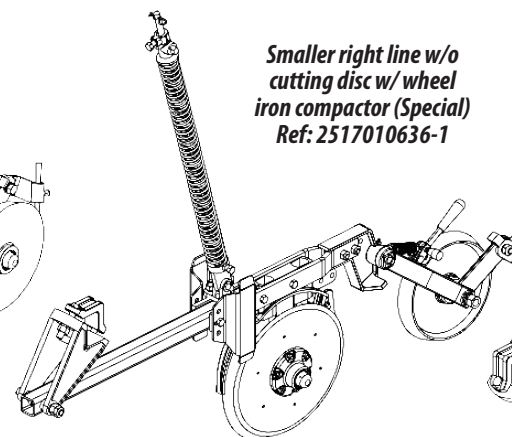

*Smaller right line w/o cutting disc w/ wheel iron compactor (Special)  
Ref: 2517010636-1*

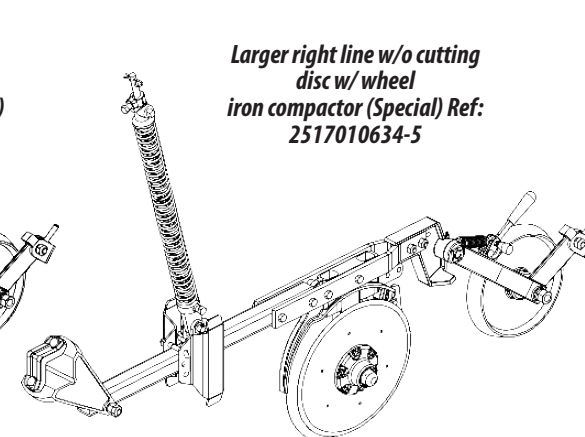

*Larger right line w/o cutting disc w/ wheel iron compactor (Special) Ref: 2517010634-5*

**OPTIONAL LINE MODELS - CONTINUATION**

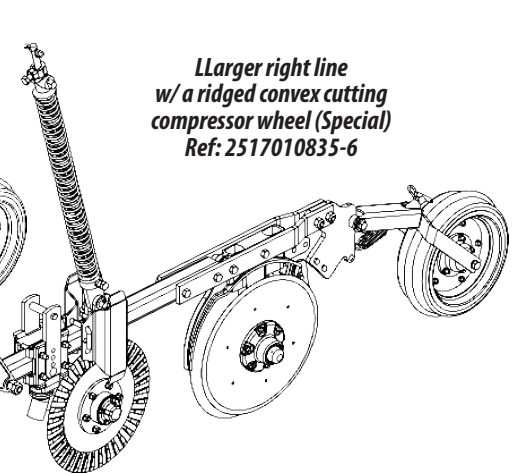
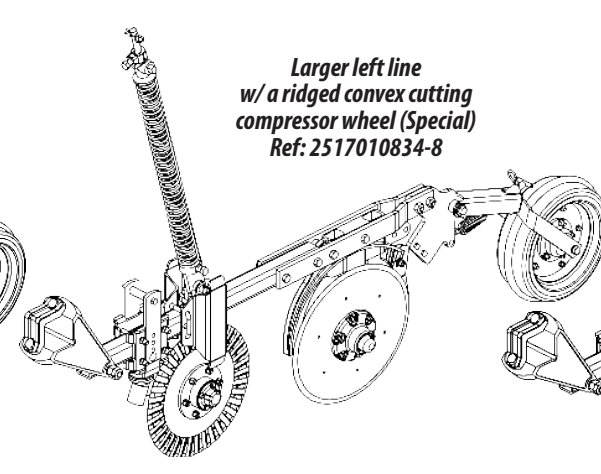
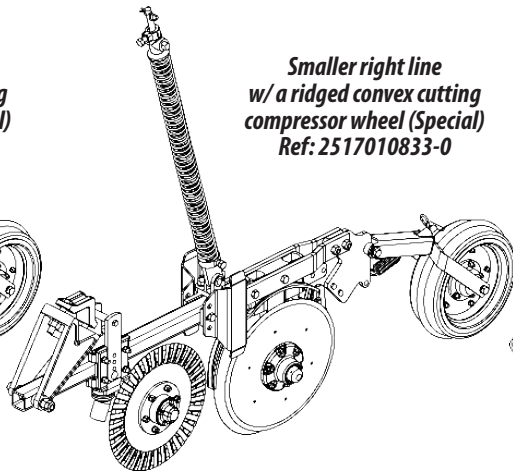
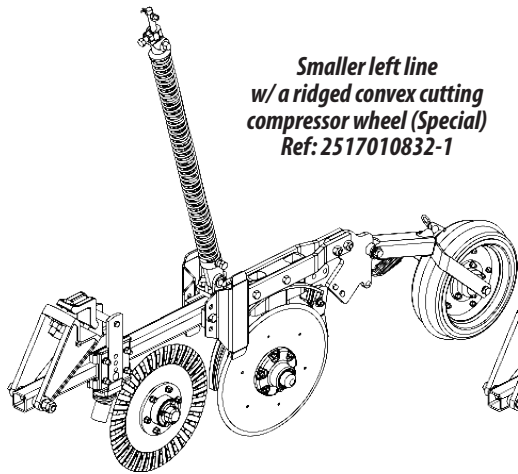
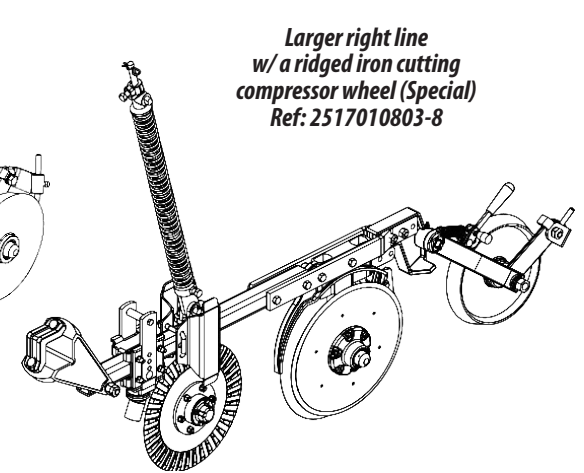
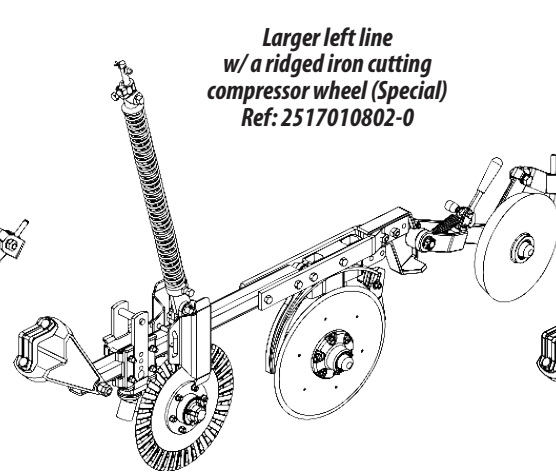
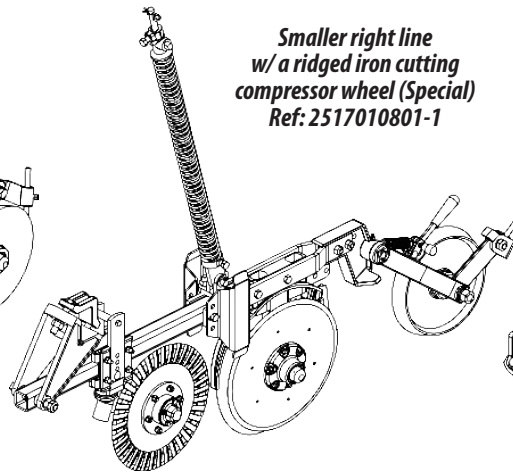
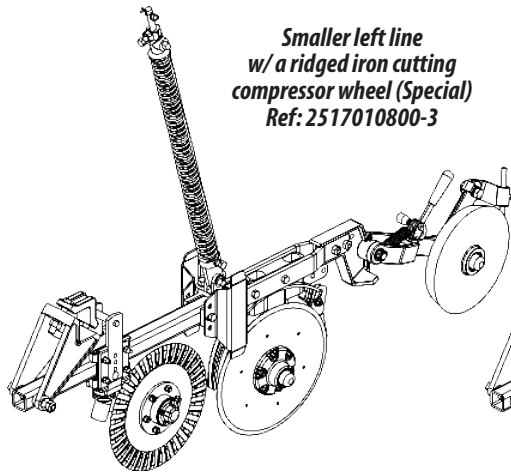

**PLANTING LINES**

# PLANTING LINES

## OPTIONAL LINE MODELS - CONTINUATION

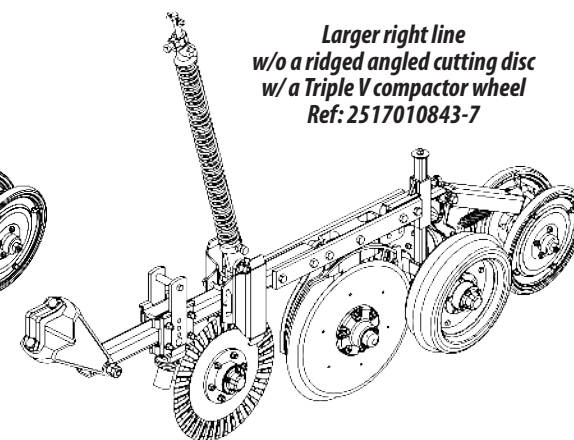
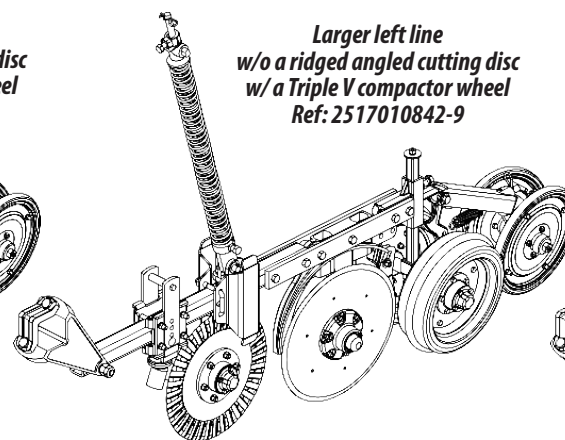
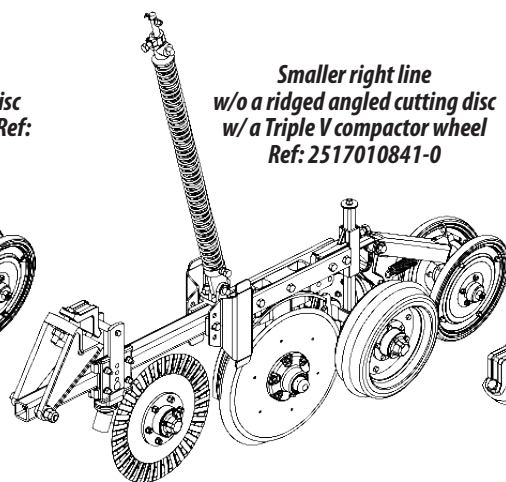
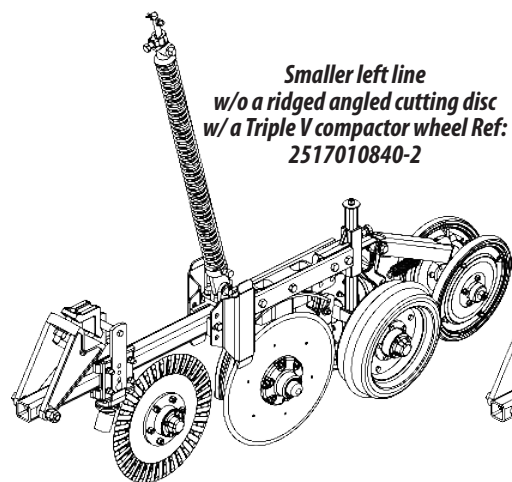
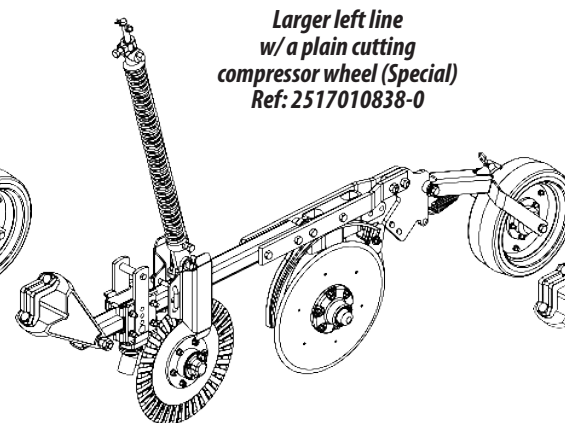
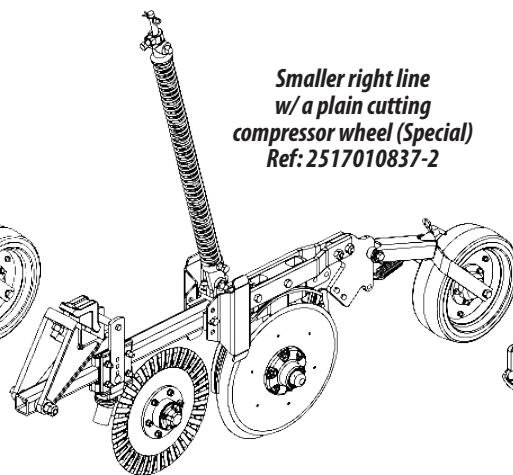
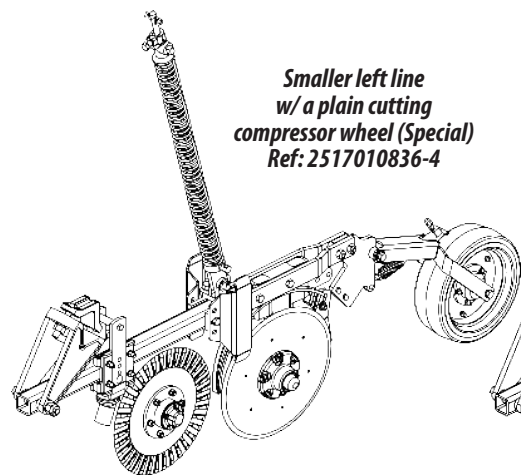

**OPTIONAL LINE MODELS - CONTINUATION**

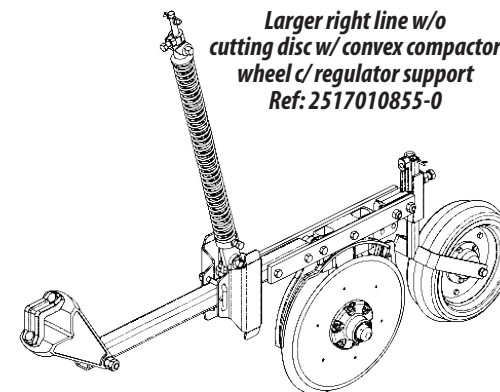
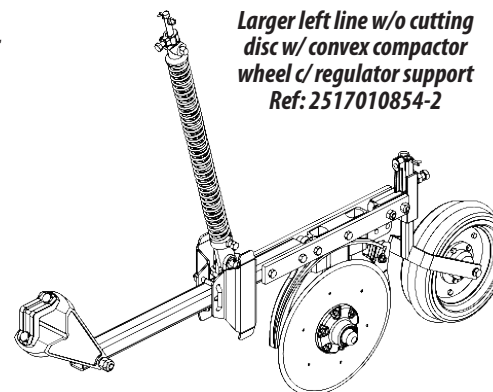
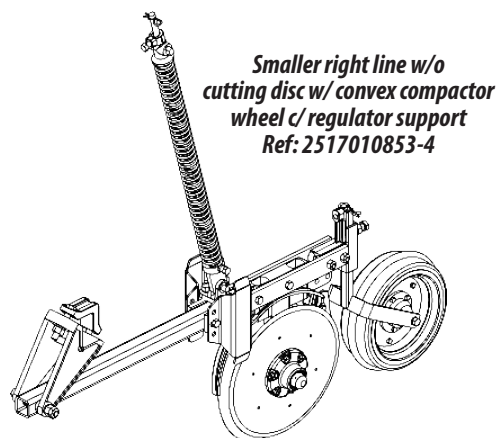
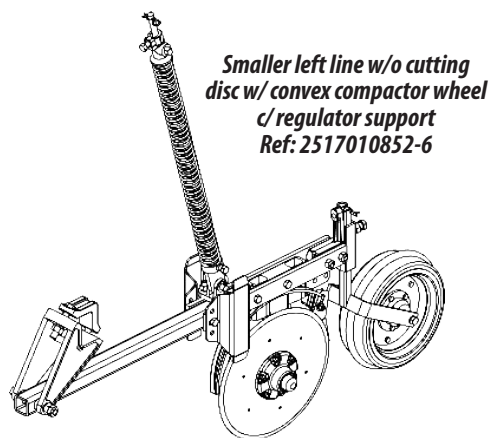
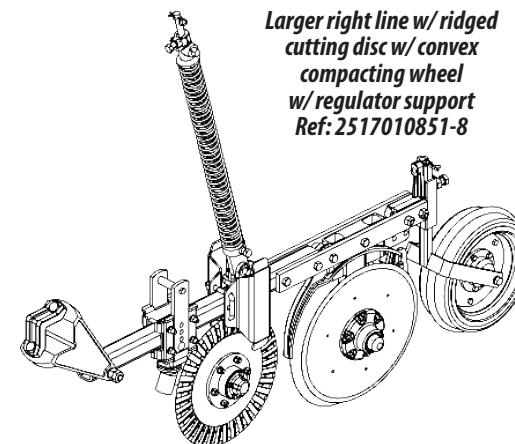
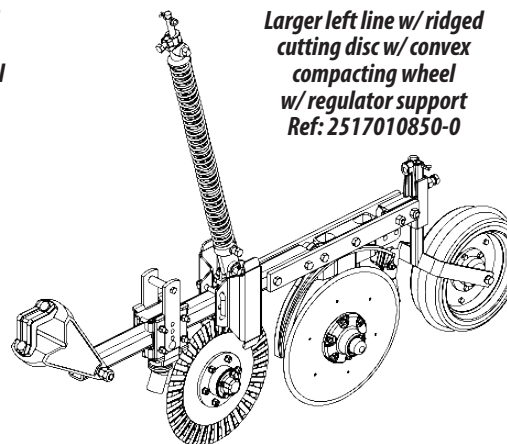
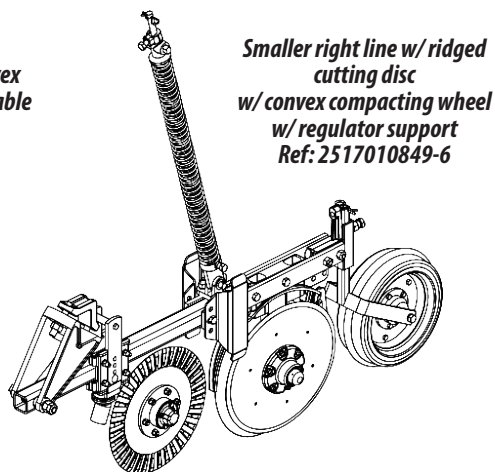
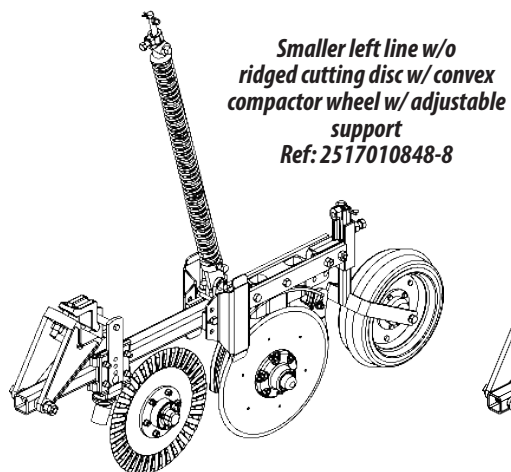

**PLANTING LINES**

# PLANTING LINES

## OPTIONAL LINE MODELS - CONTINUATION

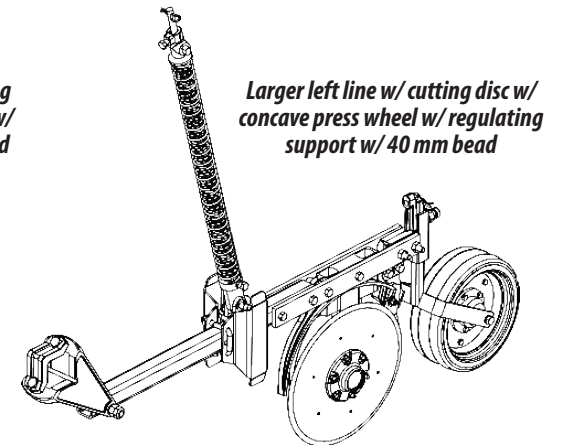
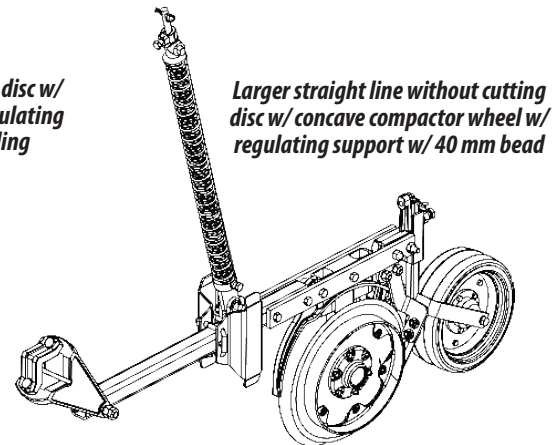
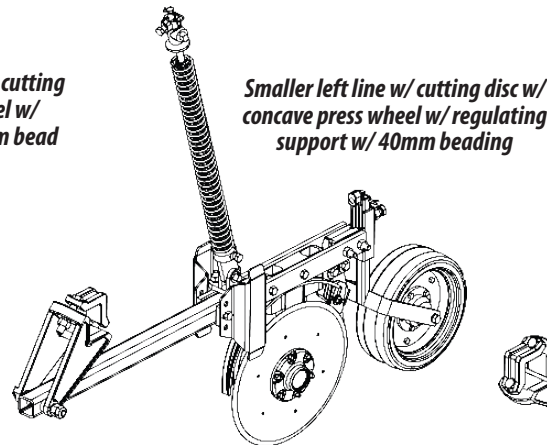
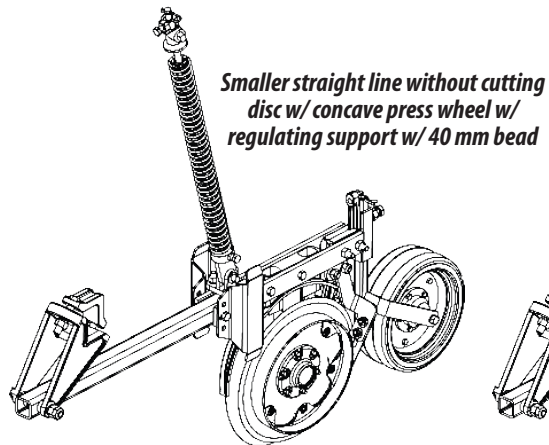
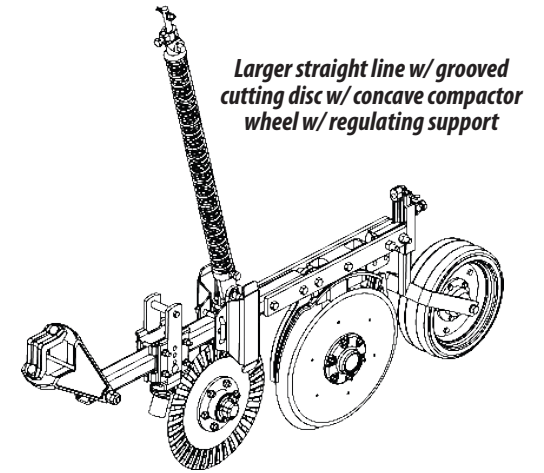
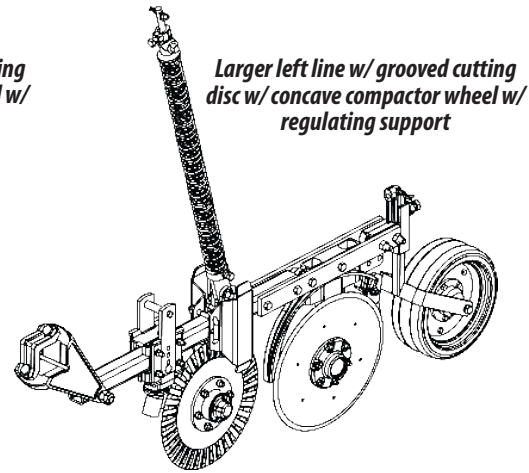
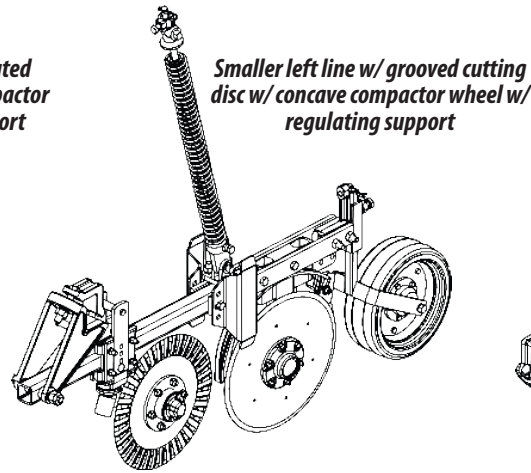
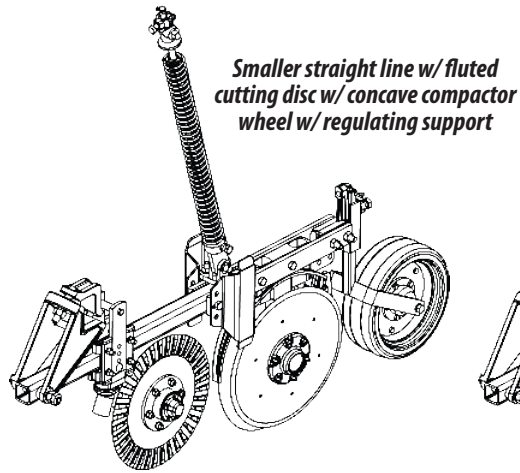

**OPTIONAL LINE MODELS - CONTINUATION**

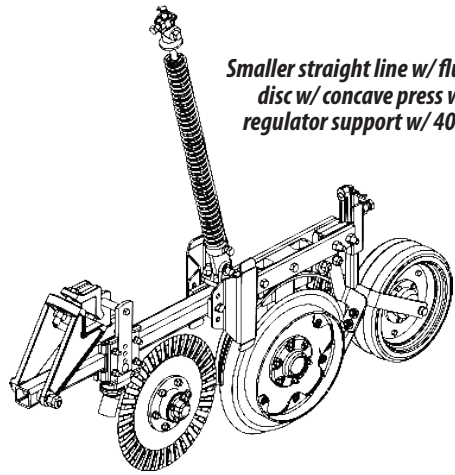

*Smaller straight line w/ fluted cutting disc w/ concave press wheel w/ regulator support w/ 40 mm bead*

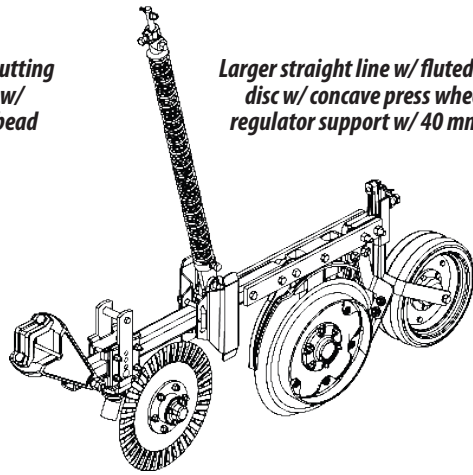

*Larger straight line w/ fluted cutting disc w/ concave press wheel w/ regulator support w/ 40 mm bead*

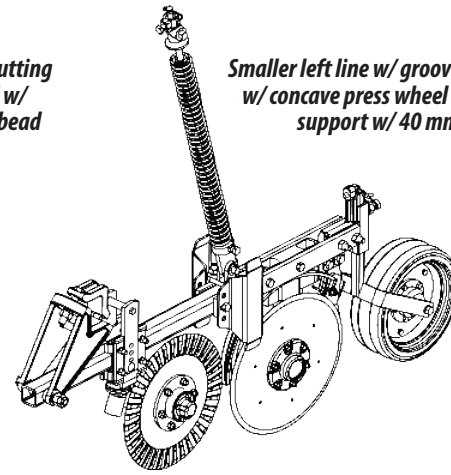

*Smaller left line w/ grooved cutting disc w/ concave press wheel w/ regulator support w/ 40 mm bead*

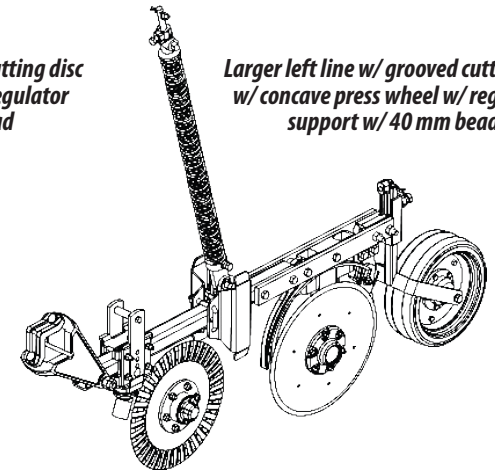

*Larger left line w/ grooved cutting disc w/ concave press wheel w/ regulator support w/ 40 mm bead*

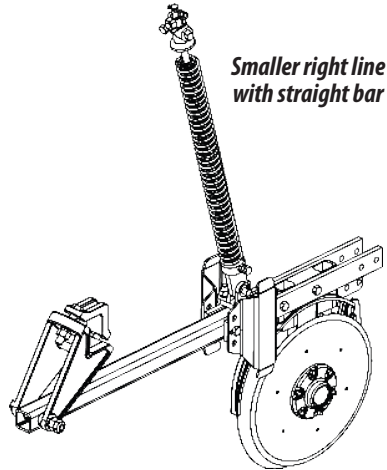

*Smaller right line with straight bar*

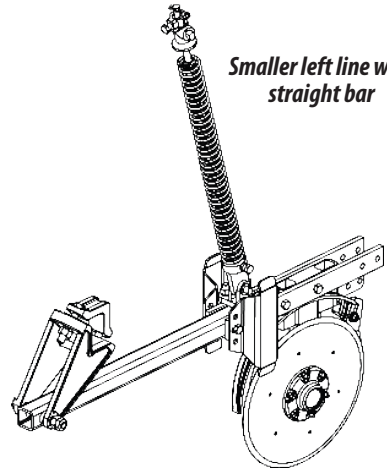

*Smaller left line with straight bar*

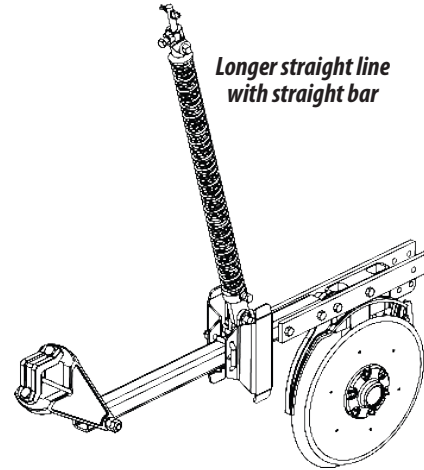

*Longer straight line with straight bar*

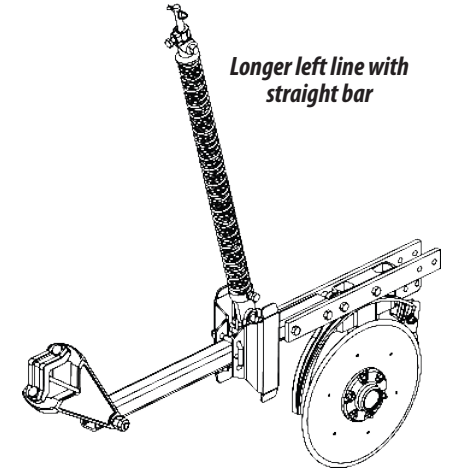

*Longer left line with straight bar*

**PLANTING LINES**

# PLANTING LINES

## OPTIONAL LINE MODELS - CONTINUATION

*Smaller straight line with straight bar with 40 mm beading*

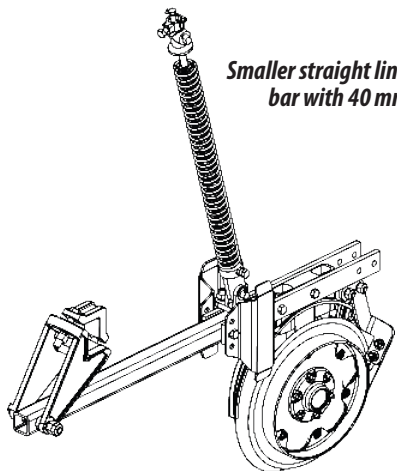

*Longer straight line with straight bar with 40 mm crimp*

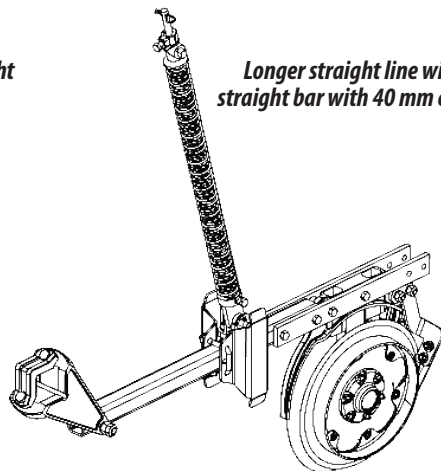

*Smaller left line with straight bar with 40 mm crimp*

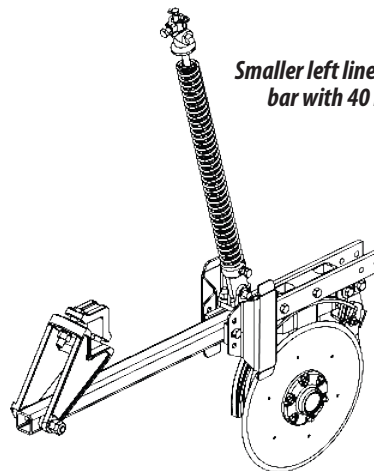

*Larger left line with straight bar with 40 mm crimp*

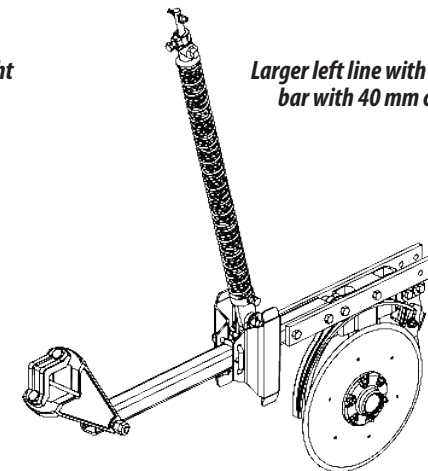

### SPRING PRESSURE ADJUSTMENT

The depth adjustment of the seeder is done by the pressure of the springs and the piston limiters.

The pressure of the springs depends on the conditions of the soil and the sowing system (conventional or direct) that allows different adjustments, observing the combinations of the springs in such a way:

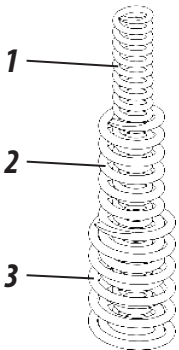
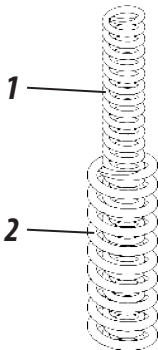
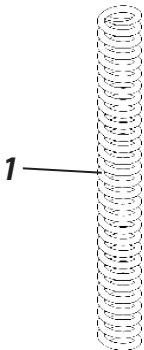
System of TRIPLE SPRIN	System de DOUBLE SPRINGS	System of SIMPLE SPRINGS
		
Internal Spring (1), Intermediate (2) and external (3).	Spring (1), and Intermediate (2).	Internal Spring (1).
For planting directly in COMPACTED SOIL	For planting directly SOIL W/ MEDIUM COMPACTION	For planting directly and conventional for SOIL W/ LOW COMPACTION

- 1- Loosen the bushing (4) through the screw (5) and secure it to the rod in order to release the lowering of the line. Secure the bushing about 5 cm above the rod support (6).
- 2- Loosen the bushing (7) through the screw (8) and secure the above in order to give pressure to the springs (9) for better penetration of the line.

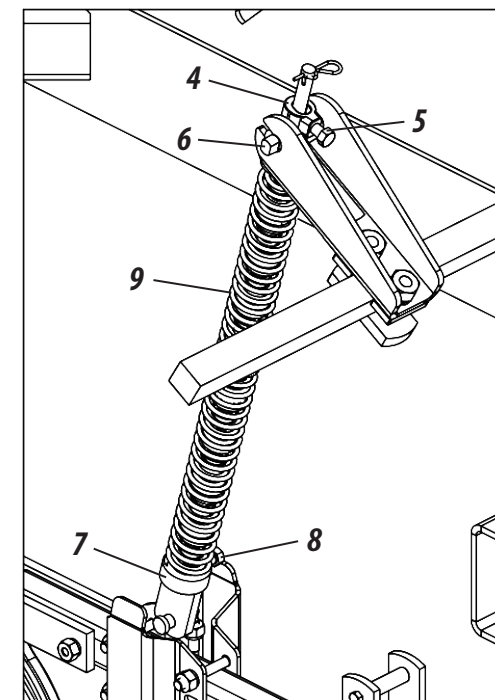

### ATTENTION

The depth capacity of the seeder is due to the appropriate and combined pressure of the active elements of the seeder. During the planting on land where there are variations in soil moisture or other factors, check the depth of work several times.

### IMPORTANT

The excess pressure in the springs causes the machine to be raised by the reaction of the soil being penetrated.

## ADJUSTMENTS OF THE LINES

# ADJUSTMENTS OF THE LINES

## LIMITERS

The limiting rings are used to limit the course of the piston, causing the disc lift bracket to compress the springs by giving the pressure required. Limiters are provided in the following sizes:

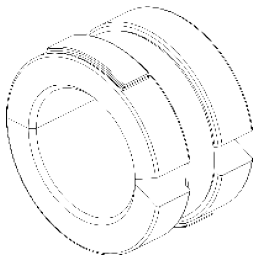
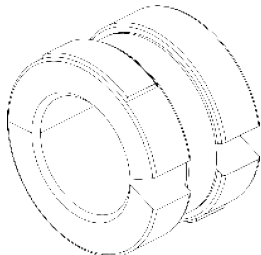
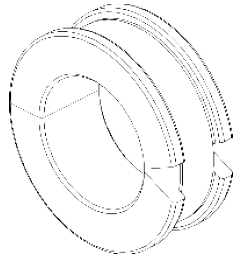
02 Limiting rings of ø 51 x 49,5 mm	02 Limiting rings of ø 42 x 49,5 mm	02 Limiting rings of ø 42 x 25 mm
		
<b>Limiter code</b> 53480500128	<b>Limiter code</b> 53480500098	<b>Limiter code</b> 53480500063

## IMPORTANT

*The limiters can be used as follows:  
25, 50 and 75mm limiting of the  
course of the piston.*

## ATTENTION

*Place the limiting rings on both sides  
of the seeder to avoid damage to the  
chassis.*

## DEPTH LIMITER FLANGE

The depth limiter flange (1) is mounted on the double disc (2) and is intended to determine the depth of position of the fertilizer and seed.

## ATTENTION

*The depth limiting flap (1)  
has 3 models as shown on  
page 75.*

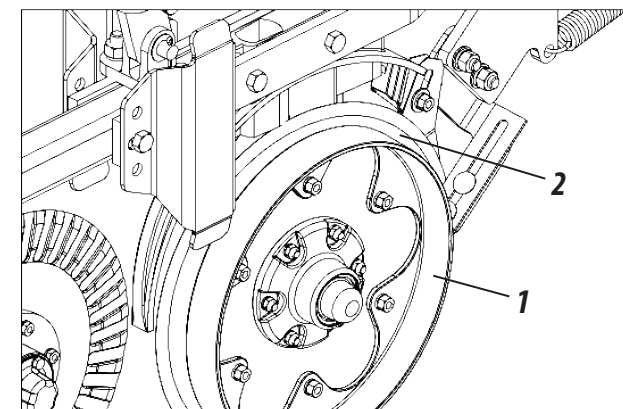

## ADJUSTMENT OF THE "V" COMPACTOR WHEEL

The compactor wheel (1) is used to close the groove sideways, causing the soil to be immediately placed on the seed, avoiding much compaction, facilitating germination and development of the plant. To adjust the pressure of the "V" compactor wheels, proceed as follows:

### MORE PRESSURE:

Remove the lock (2), pull the pin (3) out and lock again.

### LESS PRESSURE:

Remove the lock (2), push the pin (3) in and lock it again.

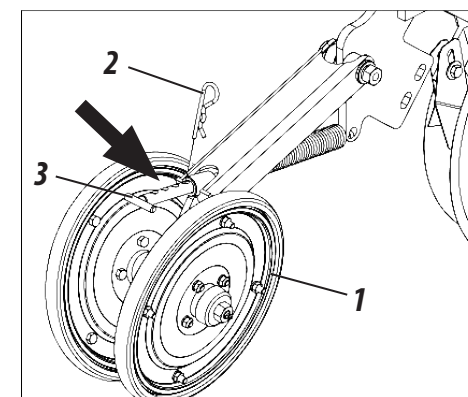

## ATTENTION

*Make the same adjustment for all "V" compactor wheels and consider the soil type, seed and depth of planting, so as not to affect the free emergence of the plants.*

### ADJUSTMENT OF THE IRON COMPACTOR WHEEL - OPTIONAL

The iron compacting wheel (1) has the purpose of pressing the groove causing the soil to be immediately placed on the seed avoiding much compactness, facilitating the germination of the plant. To adjust the pressure of the iron compacting wheel (1) proceed as follows:

- 1- First pull the handle (2) to unlock the lever (3).
- 2- Then adjust the lever (3) backwards or forwards, giving greater or lesser pressure on the iron compactor wheel (1).
- 3- Finish by releasing the handle (2) locking the lever (3).
- 4- To move the iron compactor wheel (1) horizontally, change the position of the washers (4) until you reach the desired position.
- 5- To adjust the wiper (5) in the vertical position (6) and slide it to the desired position.
- 6- To adjust the distance between the double disk (7) and the iron compactor wheel (1), release the screws (8), lock washers (9) and nuts (10), adjust the desired distance and re-tighten the bolts (8), lock washers (9) and nuts (10).

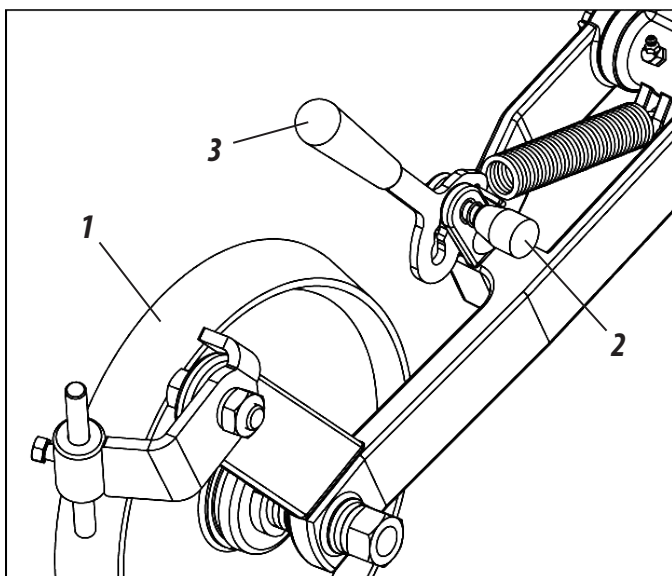

#### MORE PRESSURE:

Move the lever (3) back, giving greater pressure on the wheel (1).

#### MENOR PRESSÃO:

Move the lever (3) forward, giving less pressure on the wheel (1).

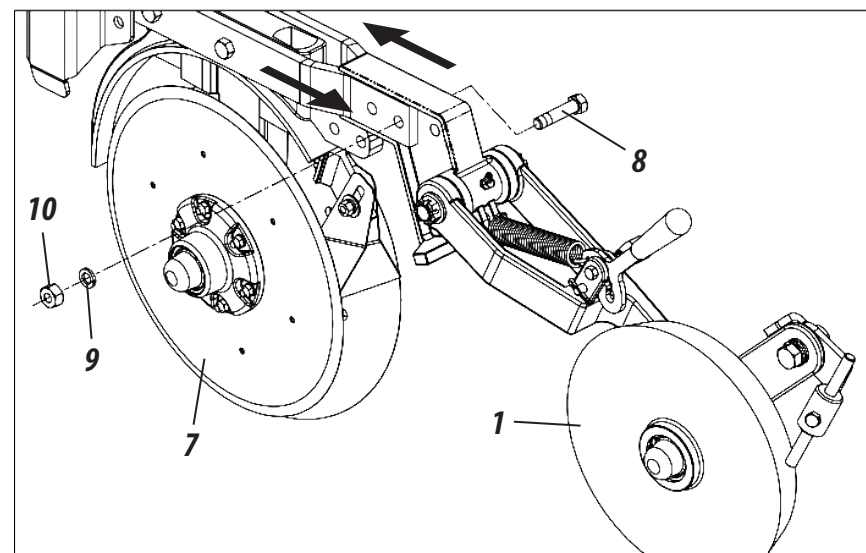
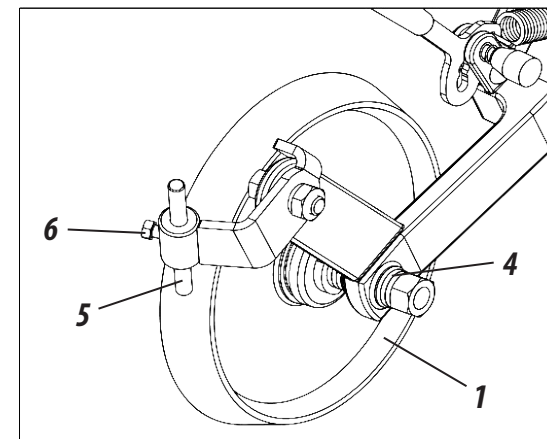

### ! ATTENTION

Perform the same setting for all iron compactor wheels and consider the type of soil, seed and planting depth, to not affect the emergence of the plantation.

## ADJUSTMENTS OF THE LINES

# ADJUSTMENTS OF THE LINES

## ADJUSTMENT OF THE SLIT OR PLAIN CUTTING DISC

To adjust the depth of the ridged or plain cutting disc (1), proceed as follows:

- 1- Remove the lock (1) and the pin (2), adjust the height of the bracket (3) and fix the bracket again.

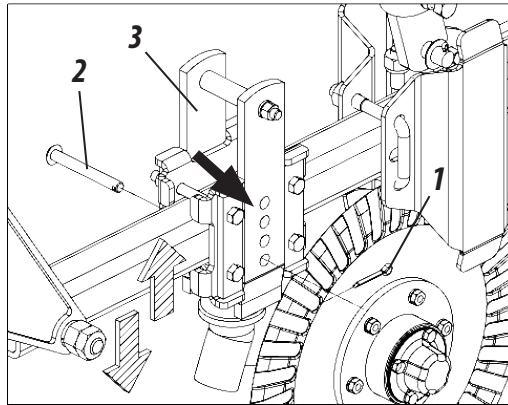

To move the ridged or plain cutting disc (1) in the horizontal position, proceed as follows:

- 2- Loosen the bolts (4), lock washers (5) and springs (6), move the disc to the desired position and lock it again.

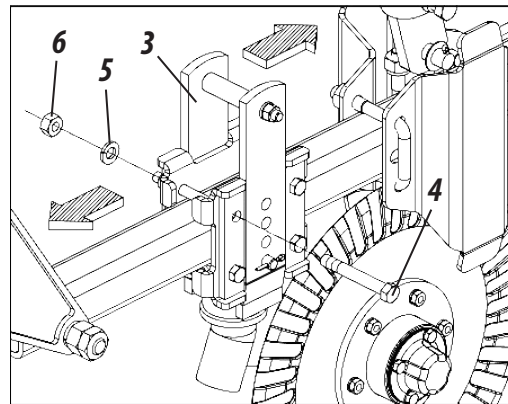

### ATTENTION

*When finalizing the adjustment, repeat this procedure on all cutting discs, avoiding variation between the lines.*

## ADJUSTMENT OF ANGLE AND DEPTH LIMITER WHEEL DEPTH

The angle of the depth limiting wheels (1) is to pressure the groove, causing the soil to be immediately replaced over the seeds, avoiding excessive compaction, facilitating the germination and development of the plant.

The wheels are fixed to a shaft with the ends angled (2), specially designed to allow compacting, depth control and burying of the seeds. To obtain these settings on the wheel, loosen the nut (3) and turn the axle (2), observing the wheel movements.

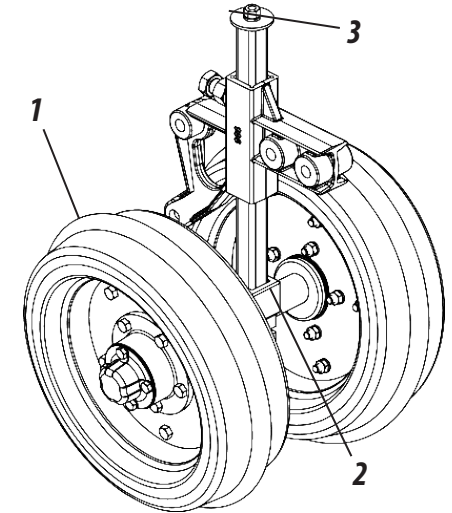

### WHEEL ANGLE POSITIONS:

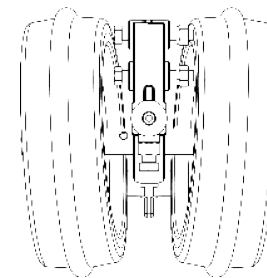

**ANGLE POSITION  
TOTALLY CLOSED:**  
Minus the earth on the seed.

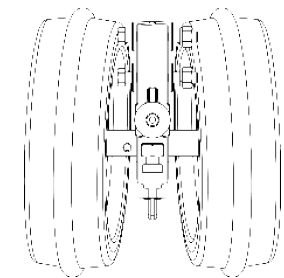

**ANGLE POSITION  
TOTALLY CLOSED:**  
More earth on the seeds.

**COMPACTOR WHEEL REGULATION - OPTIONAL**

It is optional that the **SPDE CXP** be bought with the line (1) mounted with the compacting wheel (2). The compacting wheel (2) has the purpose of pressing the groove causing the soil to be immediately placed on the seed avoiding much compactness, facilitating plant germination. To adjust the compression wheel (2), proceed as follows:

- 1- Loosen the counter nut (3) and the screw (4).
- 2- Then move the compactor wheel (2) to the desired position.
- 3- Finish by tightening the bolt (4) and counter nut (3).

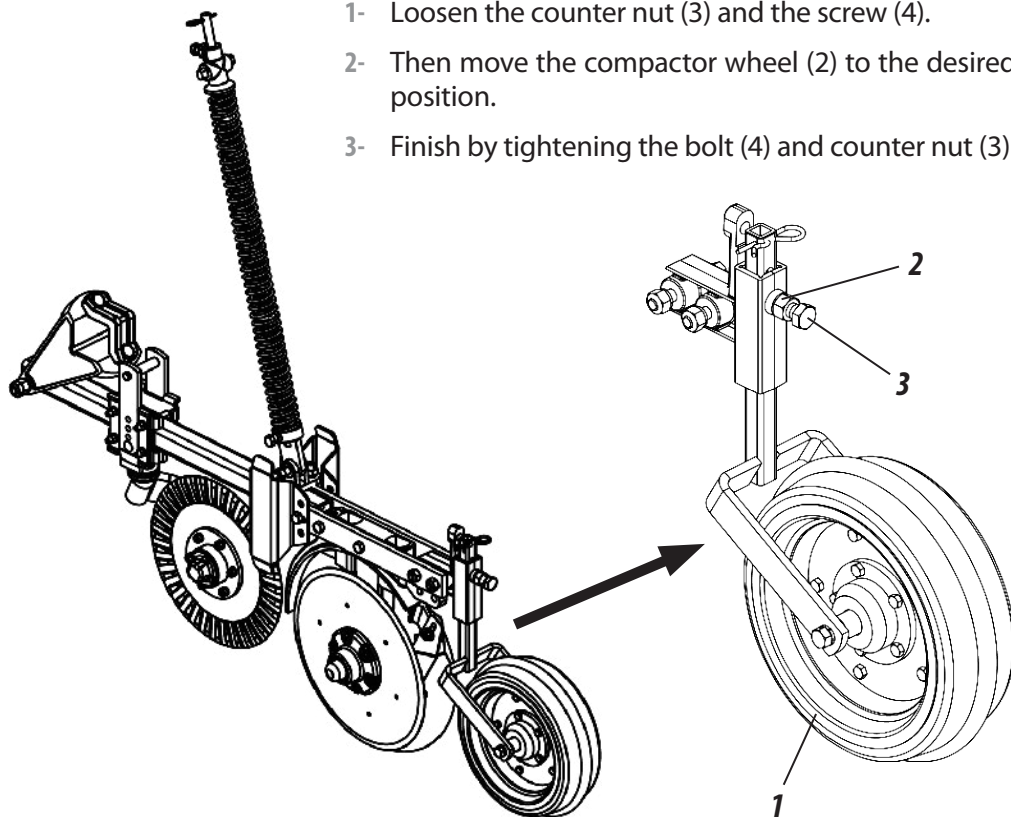

**ADJUSTMENT OF THE DOUBLE DISK CLEANERS**

The dual disc (1) has wiper blades (2) which are flexible and adjustable to remove the soil adhering to the discs. To adjust the wiper (2) proceed as follows:

- 1- Loosen the screw (3), adjust the cleaners (2) in the ideal position and tighten the screw (3).

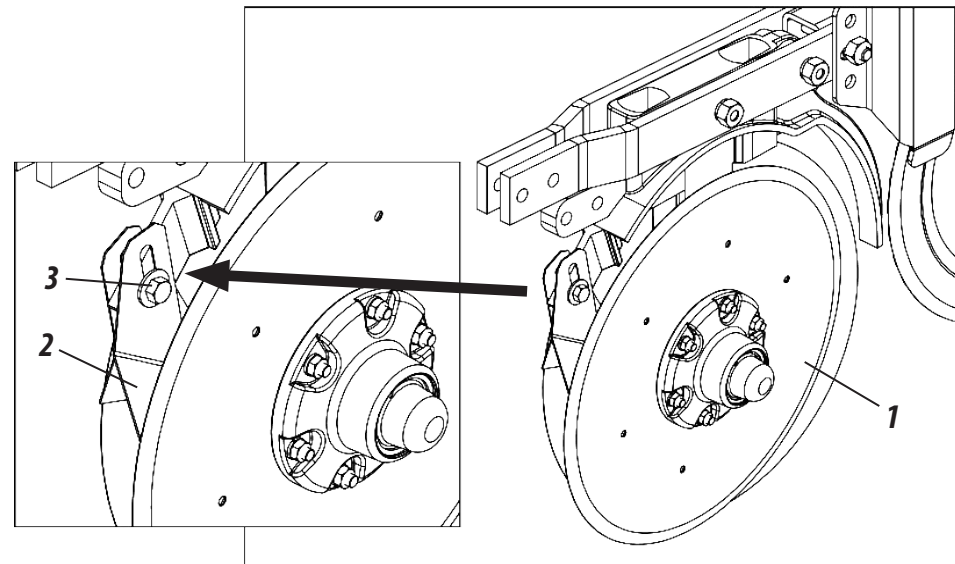

**ATTENTION** | *When making the adjustments mentioned on this page, they should be done to all lines, considering the type of soil, seed and depth of planting, so as not to affect the free emergence of the plants.*

**ADJUSTMENTS OF THE LINES**

# OPERATION

## COUNTERWEIGHTS

The **SPDE CXP** has counterweights (1) which are placed in the rear tube (2) of the seeder. These counterweights have the purpose of aiding in penetrating of hard terrain, especially when there is a tendency to skid the wheels. Weighing 14.6 kg each, the counterweights (1) can be removed or placed easily.

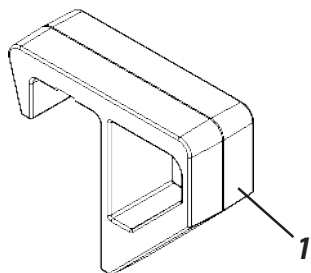

Models	Number of Counterweights	Total (KG)
SPDE CXP	16	234
SPDE CXP	20	292
SPDE CXP	24	350

To place or remove counterweights (1), proceed as follows:

- 1- Loosen the bolts (3), plain washers (4), lock washers (5) and nuts (6), remove the platform plate (7). Then remove the bolts (8), plain washers (9) and plate (10).
- 2- Then, insert one on each side, another in the middle, and so on. Finish by assembling the components again.

### ATTENTION

*Do the same for the other wheel support (6) and for all the oscillating depth wheels.*

### IMPORTANT

*During sowing, check the depth a few times, especially when there is moisture variation.*

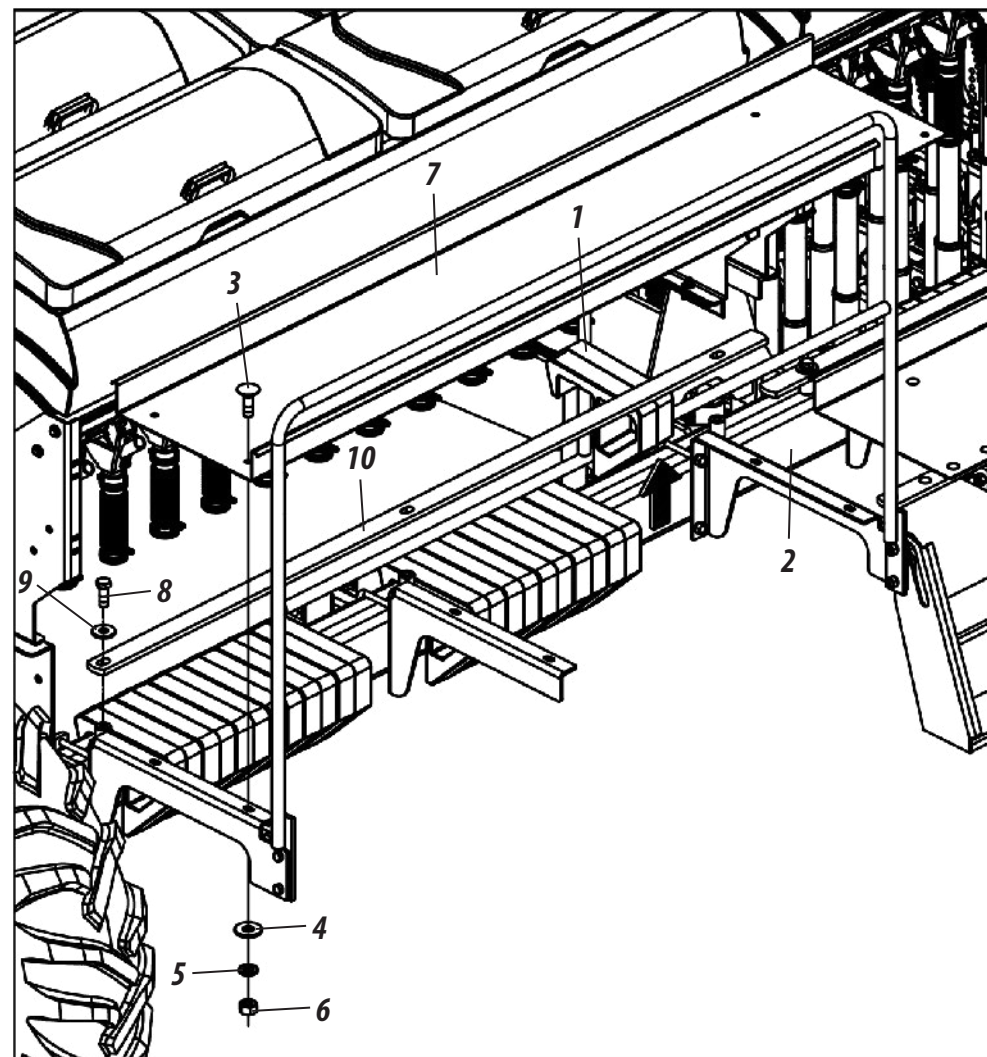

**RECOMMENDATIONS FOR OPERATION**

- 01 - After the first day of work with the seeder, retighten all screws and nuts. Check the condition of the pins and locks.
- 02 - Do not maneuver or reverse with the lines down on the ground.
- 03 - Observe the lubrication intervals.
- 04 - When filling the tanks, check for objects in them, such as nuts, bolts, etc. Always use seeds free from impurities.
- 05 - Always observe the operation of the seeds distribution mechanisms and also the adjustments established at the beginning of planting.
- 06 - Always keep the seeder leveled, the tractor drawbar must remain fixed and the working speed should remain constant.
- 07 - Always check the depth of seeds and the pressure of the compactor wheels.
- 08 - Note the position of the fertilizer in relation to the seed in the soil.
- 09 - When performing any checks or maintenance on the seeder, lower it to the ground and switch off the tractor engine.
- 10 - Do not make sharp turns with the seeder during work, especially in direct planting. The components of the lines may be damaged.
- 11 - Do not partially activate the hydraulic cylinders. The activation for raising or lowering of the seeder should always be complete.
- 12 - The sower has several settings but only local conditions can determine the best setting.
- 13 - Only fill the seeder in the workplace.
- 14 - Do not transport or work with an overload on the seeder.
- 15 - The right and left side readings are made by observing the sower from behind.
- 16 - The **SPDE CXP** seeder operates more efficiently in the range of 5 to 7 km / h.
- 17 - If in doubt, never operate or handle the seeder, contact Post Sales.
- 18 - Telephone: 0800-152577 or Email: [posvenda@baldan.com.br](mailto:posvenda@baldan.com.br)

# MAINTENANCE

## TIRE PRESSURE

- 1- Tires should always be properly calibrated to avoid premature wear due to excess or lack of pressure, also ensuring accuracy in distribution.
- 2- The calibration of the **SPDE CXP** tires should be of **24 lb / in<sup>2</sup>**.

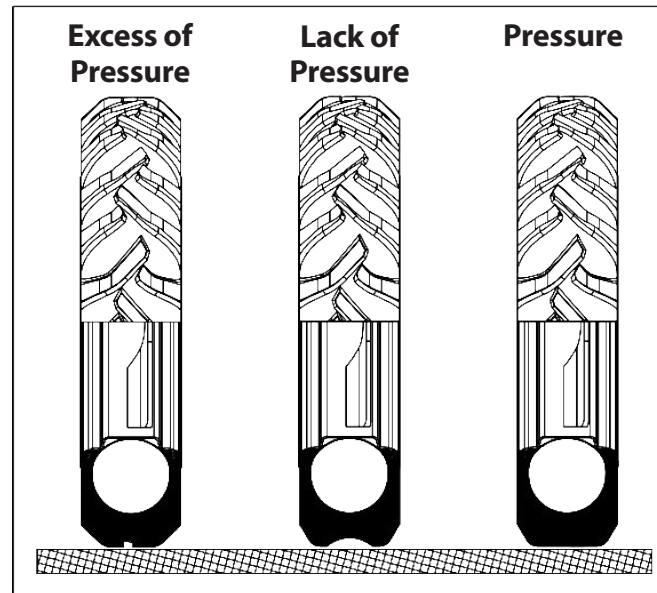

## ⚠ ATTENTION

*When calibrating the tires of the seeder, do not exceed the recommended tire calibration.*

*Always keep all tires of the same model with the same calibration to avoid wear and maintain uniformity of planting.*

## 🔄 NOTE

*If necessary, put 3/4" of water in the tires and maintain the same recommended calibration.*

## LUBRIFICATION

- 3- Lubrication is indispensable for the good performance and durability of the **SPDE CXP**, contributing to the maintenance cost savings.

- 4- Before starting the operation, carefully lubricate all grease fittings, always observing the greasing intervals on the following pages. Make sure of the lubricant quality, regarding its efficiency and purity, avoid using products contaminated with water, earth and other agents.

## TABLE OF GREASE AND EQUIVALENTS

MANUFACTURER	RECOMMENDED GREASE TYPES
Petrobrás	Lubrax GMA 2
Atlantic	Litholine MP 2
Ipiranga	Super Graxa Ipiranga Ipíringa Super Graxa 2 Ipiflex 2
Castrol	LM 2
Mobil	Mobilgrease MP 77
Texaco	Marfak 2 Agrotex 2
Shell	Retinax A Alvania EP 2
Esso	Multipurpose grease H
Bardahl	Maxlub APG 2 EP

## 🔧 IMPORTANT

*If there are other lubricants and/or equivalent grease brands listed in this table, refer to the lubricant manufacturer's own technical manual.*

LUBRICATE EVERY 10 HOURS OF WORK

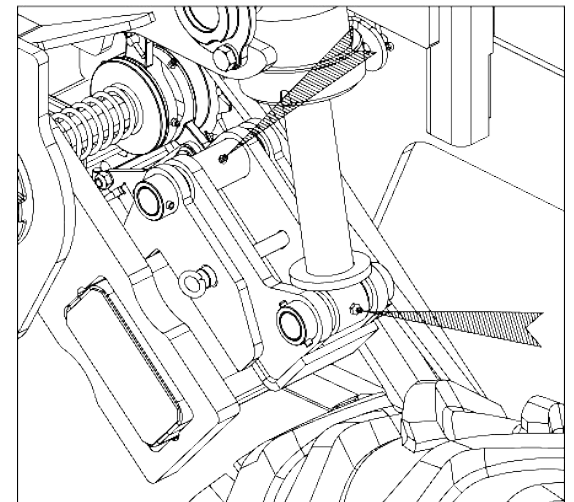
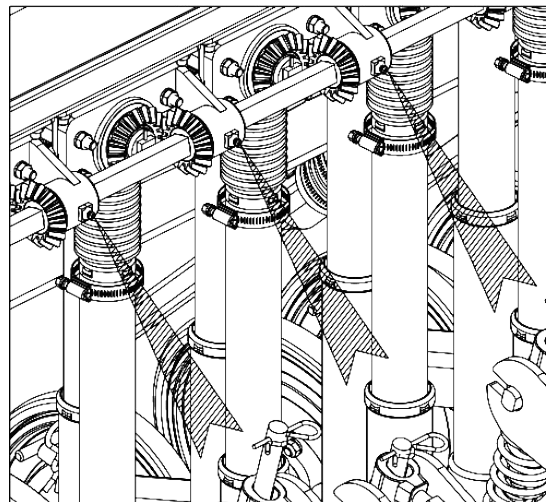
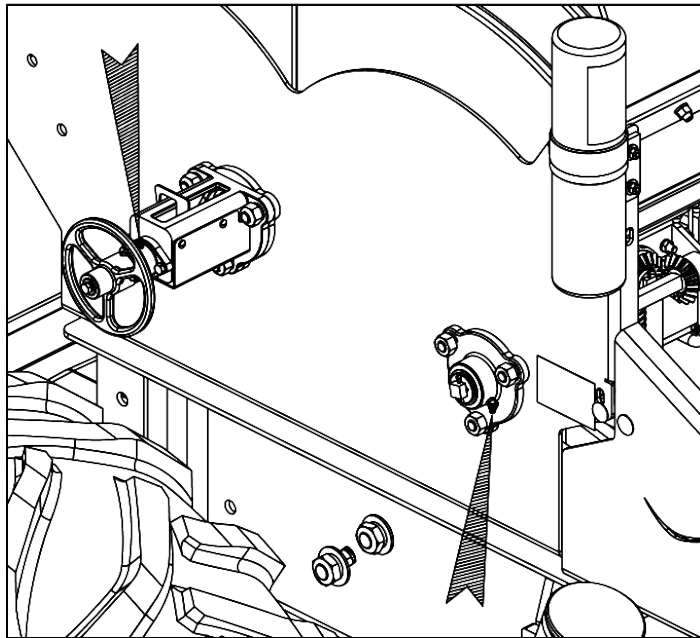
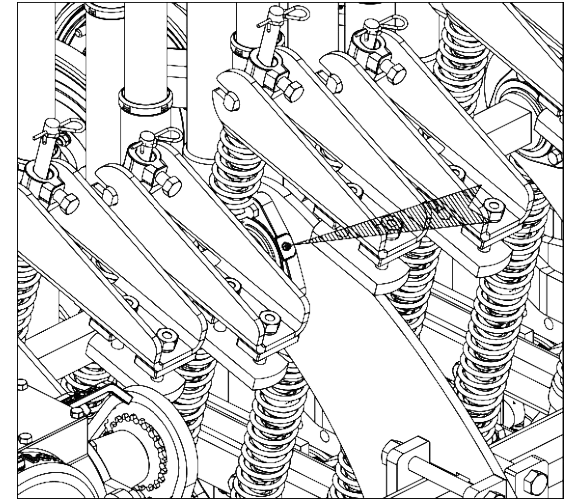
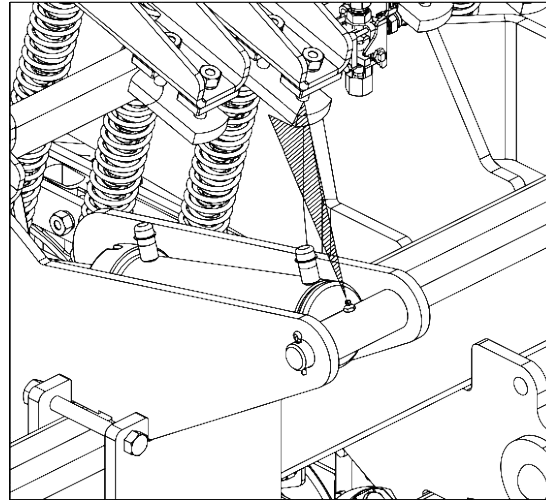
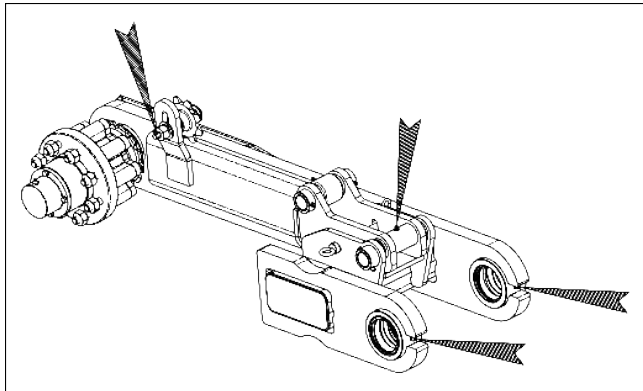

**MAINTENANCE**

# MAINTENANCE

## LUBRICATE EVERY 10 HOURS OF WORK

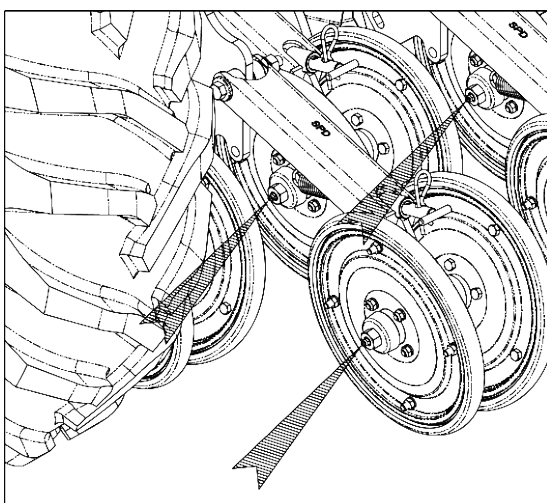
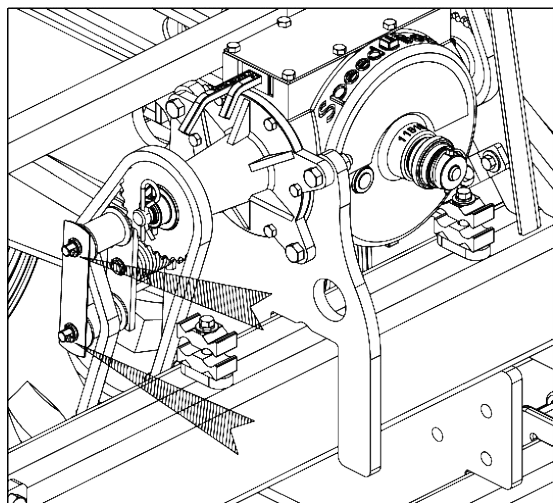
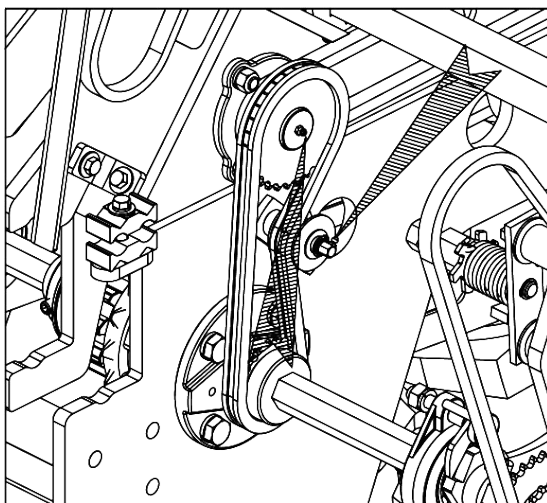
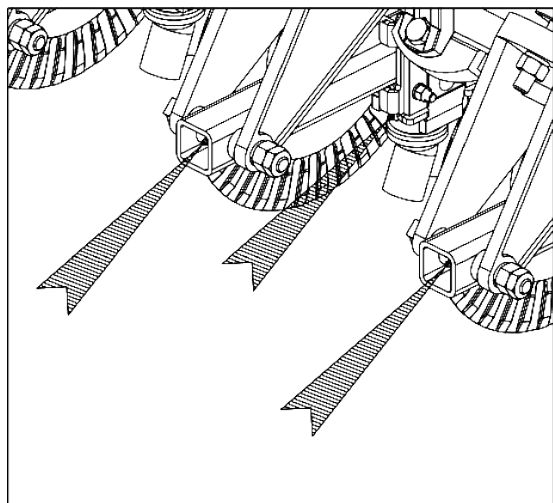

To lubricate the line markers hub (1) proceed as follows:

- 1- Remove the retaining ring (2) from the hub (3). Examine the bearings and if there are gaps, adjust using the castle nut (4). Insert new grease into the cap (5). Replace the cap (5) on the hub and secure it with the retaining ring (2).

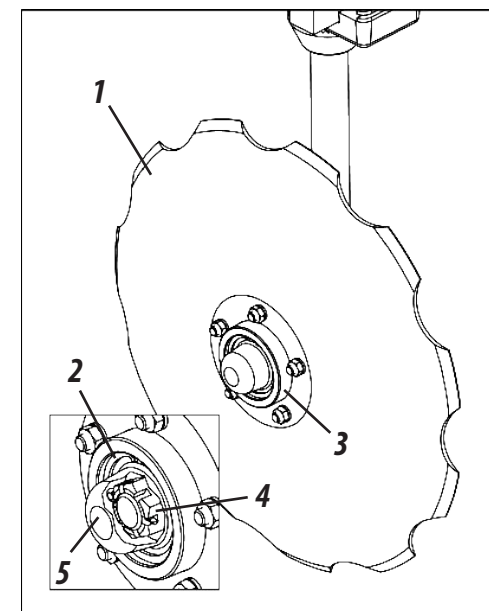

### **⚠ ATTENTION**

*Before removing the cap (5), clean the outside so as not to contaminate the inside.*

*Do not put excess grease, observe the lubrication intervals.*

LUBRICATE EVERY 30 HOURS OF WORK

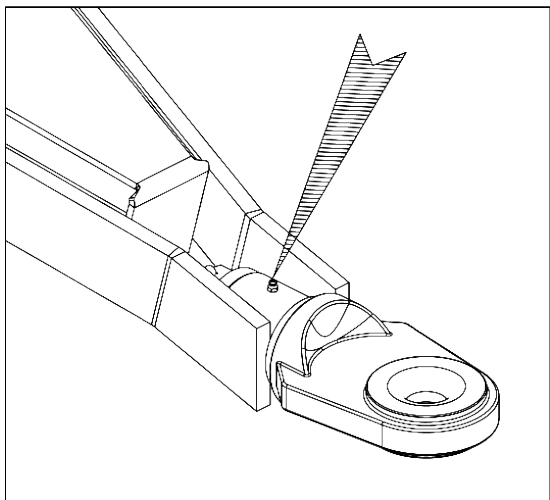
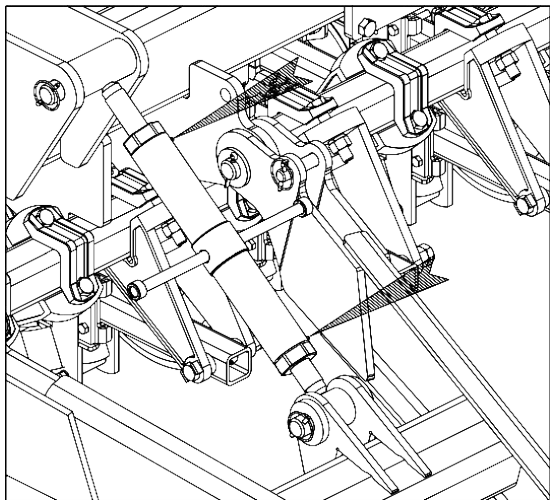

LUBRICATE EVERY 60 HOURS OF WORK

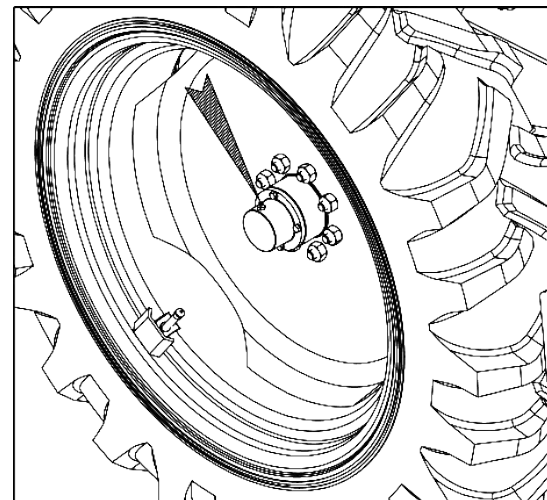
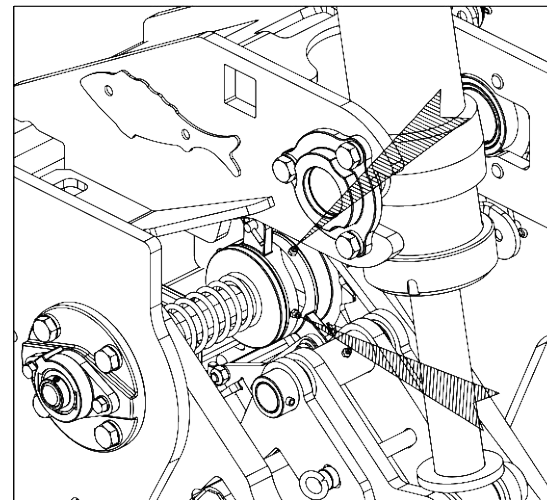

**! ATTENTION**

*Do not put excess grease, observe the lubrication intervals.*

**MAINTENANCE**

# MAINTENANCE

## LUBRICATE EVERY 200 HOURS OF WORK

Periodically lubricate the double disc hubs (1) approximately every 200 hours and at the end of the harvest, to do this proceed as follows:

- 1- Remove the retention ring (2) of the hub (3). Examine the bearings, if there are any gaps, adjust through the castle nut (4). Introduction new grease in the cap (5). Replace the cover (5) on the hub and secure it with the retaining ring (2).

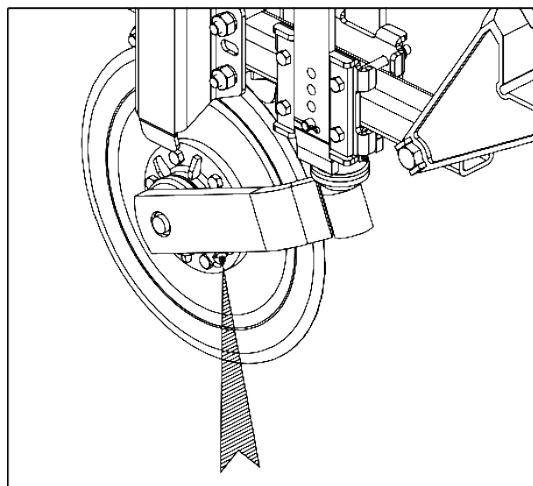
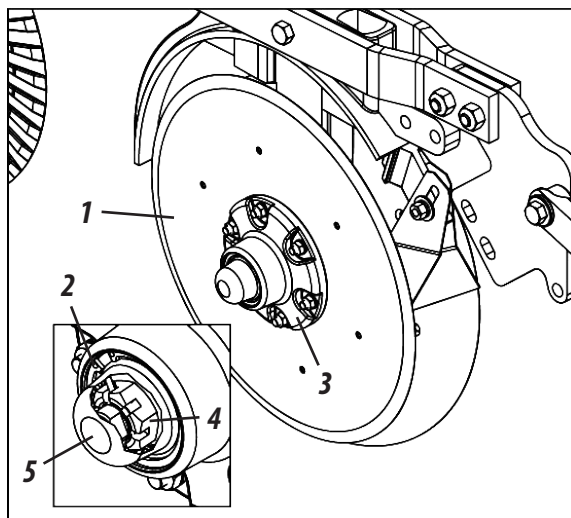

### ! ATTENTION

*Before removing the cap (5), clean it on the outside so that it does not contaminate the inside.  
Do not over-grease, respect the greasing intervals.*

## CHAIN TENSION

To tension the chain, proceed as follows:

- 1- Loosen the nut (1), slide the tensioner (2) by adjusting the chain tension (3). Then retighten the nut (1).

### ! ATTENTION

*Check the chain tension daily 1, the normal loosening should be +/- 1cm in their center.*

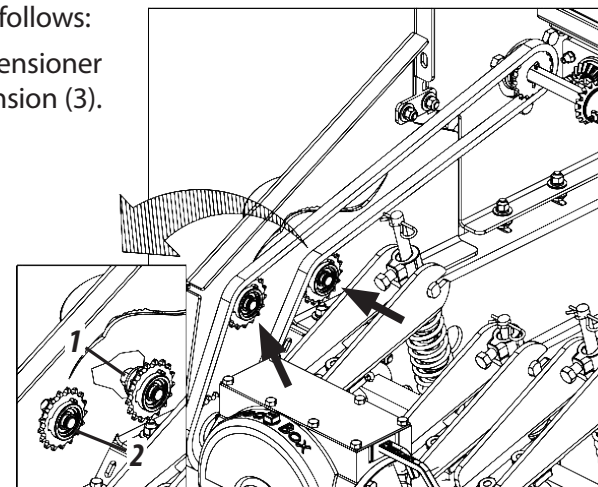

## OSCILLATING TENSIONER

The tensioner (1) is of the torsion type (2) for even greater tensioning. If necessary on the tensioner, loosen the spring, turn the spring coupling shaft (2) to the shaft rosette and rest the inner nut (3).

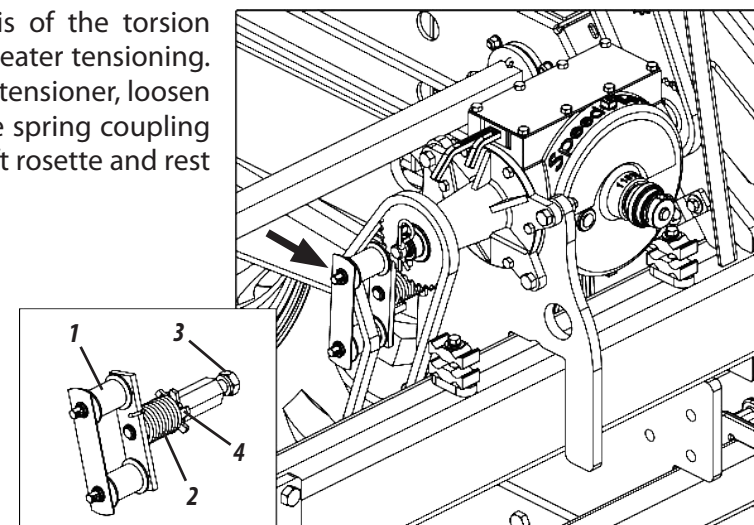

## OPERATIONAL MAINTENANCE

PROBLEMS	PROBABLE CAUSES	SOLUTIONS
During planting it begins to leak fertilizer through the outlets of the safety devices.	Hoses clogged, foreign body in the fertilizer distribution nuts.	Unclog the fertilizer hoses or remove the upper gutter channel that gives access to the spiral, turn the shaft in the opposite direction until the foreign body leaves and the rod threads.
Fertilizer hub rod does not rotate.	Spiral blocked with moist fertilizer or foreign body.	Unclog the fertilizer distribution threads.
Can not couple couplings quickly on the tractor.	The hoses have been disengaged with pressure or are taking on the weight of the seeder in the hydraulics.	Drain the hoses or place the seeder on the support feet and finally relieve the pressure.
A planting line is less deep than the other.	Different pressure settings on the depth limiting wheels or in the springs of the line.	Set all depth wheels equally and the pressure of the line springs.
The groove is too open during planting.	Sticky soil that sticks to the discs or excessive speed of work.	Decrease the work speed.
The hydraulic cylinders stop operating, lifting the seeder and then doesn't lower or vice versa.	Different quick coupler, sphere male type and female needle type or vice-versa.	Proceed by changing the quick coupler, placing two of the same type.
Strange noise when operating or walking with the loaded seeder.	Loose wheels or wheel hub.	Re-tighten the wheel nuts. Adjust the wheel hub bearings.
The seeder leaves the planting line, sometimes to one side, sometimes to the other, sideways.	Loose tractor drawbar.	Use the pin that comes with the seeder. Attach the tractor drawbar on the central hole.
It is not covering the groove.	Poorly adjusted covering wheels or damp grounds.	Adjust the covering wheel by moving it sideways in relation to the groove.
Very compacted soil, increasing the pressure of the discs and the discs do not operate in the desired depth.	Lack of weight on the seeder.	Place the next, add water to the tires and lock the system of wheel articulation.
The ridged discs touch the ground during transport.	The triple spring's rod bushing loosens or the regulated ridged disc is in the upper holes.	Fasten the spring rod bushings and place the ridged disc holder in the lower holes to make them taller.

## CARE

- 1- Check the condition of all pins and bolts before beginning to use the seeder.
- 2- The speed of movement must be carefully controlled according to the terrain conditions.
- 3- Baldan seeders are used in many applications, requiring knowledge and attention during their handling.
- 4- Only local conditions can determine the best working form of the seeder.

## MAINTENANCE

## MAINTENANCE

- 5- When assembling or dismantling any part of the seeder, use appropriate methods and tools.
- 6- Observe the lubrication intervals carefully at the various points of the seeder.
- 7- Always check the parts for wear. If there is a need for replacement, **always request original Baldan parts.**

## CLEANING

- 1- When storing the seeder, carry out overall cleaning and wash only with water. Make sure the paint is not worn, if this happened, paint a full coat, use protective oil and fully lubricate the seeder. Do not use burned oil and / or diesel oil.
- 2- At the end of planting, proceed as follows:
  - Remove the transmission chains and keep them soaked in oil until the next planting.
  - Remove all seed hoses immediately by washing them with water and neutral soap. Do not use other chemicals.
- 3- Fully lubricate the seeder. Check all moving parts of it, if they are worn or loose, make the necessary adjustment or replacement of the parts, leaving the seeder ready for the next planting.
- 4- After all maintenance work, store the seeder in a covered, dry place, properly supported. Do not allow the discs to come into direct contact with the ground.
- 5- When connecting or disconnecting the hydraulic hoses from the seeder, do not let the ends touch the ground. Before connecting the hydraulic hoses, clean the connections with a clean, lint-free cloth (**Do not use cotton waste**).
- 6- Replace all stickers that are damaged or missing. Make everyone aware of their importance and the dangers of accidents when instructions are not followed.
- 7- We recommend washing the seeder only with water at the beginning of the new planting.



## ATTENTION

*Do not use chemical products to wash the seeder, this may damage the paint and the adhesives.*

## SEEDER CONSERVATION - PART I

To prolong the life and appearance of the **SPDE CXP** for longer, follow the instructions below:

- 1- Fertilizers and their additives are highly corrosive and their formulation is increasingly aggressive to the seeder components.
- 2- Wash and clean all seeder components during and at the end of the work season.
- 3- Use neutral products to clean the seeder, following the safety and handling guidelines provided by the manufacturer.
- 4- Always carry out maintenance during the periods indicated this manual.

## SEEDER CONSERVATION - PART II

The practices and care below if adopted by the owner or operator make a difference to the conservation of the **SPDE CXP**.

- 1- Be careful when performing high-pressure washing; do not direct the water jet directly into the connectors and electrical components. Isolate all electrical components;
- 2- Use only NEUTRAL detergent and water (pH equal to 7);
- 3- Apply the product, following the manufacturer's instructions strictly, on the wet surface and in the correct sequence, respecting the time of application and washing;
- 4- Stains and dirt not remove with the products should be removed with the aid of a sponge.
- 5- Rinse the machine with clean water to remove any chemical residues.
- 6- Do not use:
  - Detergents with a basic active ingredient (pH greater than 7), can attack/stain the paint on the seeder.
  - **Detergents with acid active ingredient (pH less than a 7), act as stripper/remover of zinc coating (the protection of parts against oxidation).**
- 8- After drying, lubricate all chains and greases according to the recommendations in the operator's manual.
- 9- Spray all the machine, especially the zinc parts, with protective oil, following the manufacturer's application guidelines. The protective also prevents dirt from adhering to the machine, facilitating subsequent washings.
- 10- Observe curing (absorption) time and application intervals as recommended by the manufacturer.

### **ATTENTION**

*Do not use any other type of oil to protect the seeder (used hydraulic oil, "burnt" oil, diesel oil, castor oil, kerosene, etc.).*

### **IMPORTANT**

*We recommend the following protective oils:*

- *Bardahl: Agro protectiv 200 ou 300*
- *ITWChemical: Zoxol DW - Series 4000*

### **NOTE**

*Ignoring the above conservation measures may result in the loss of warranty for painted or galvanized components that may be oxidized (rust).*



- 7- Let the machine dry in the shade so that water does not accumulate in its components. Drying too fast can stain your paint.

## MAINTENANCE

# MAINTENANCE

## CLEANING THE FERTISYSTEM DRIVER

After planting, do not leave fertilizer in the tank. To clean, proceed as follows:

1- Remove the nozzle (1) through the quick coupling (2).

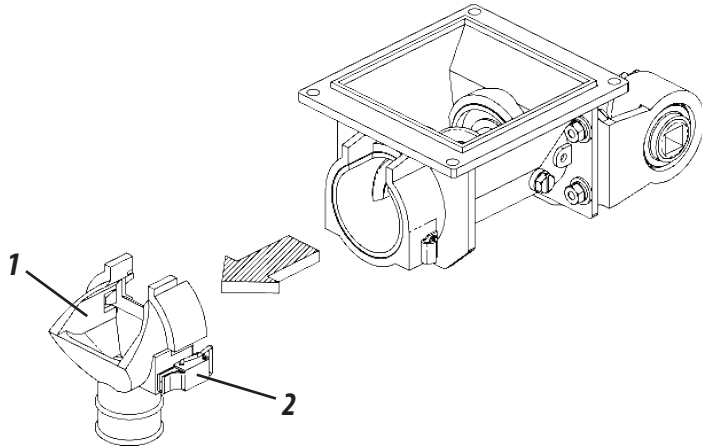

2- Remove the endless spring (3). Pulling it through the ring of the fixing tube (4), also removing the locking ring (5).

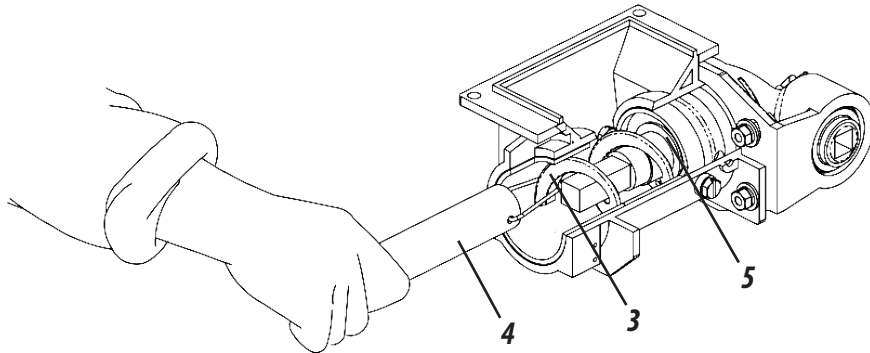

3- After cleaning, replace the endless spring (6), together with the locking ring (7), through the fixer tube (8) observing that the endless spring (6) and the locking ring (7) are well positioned in the base of the drive shaft (10).

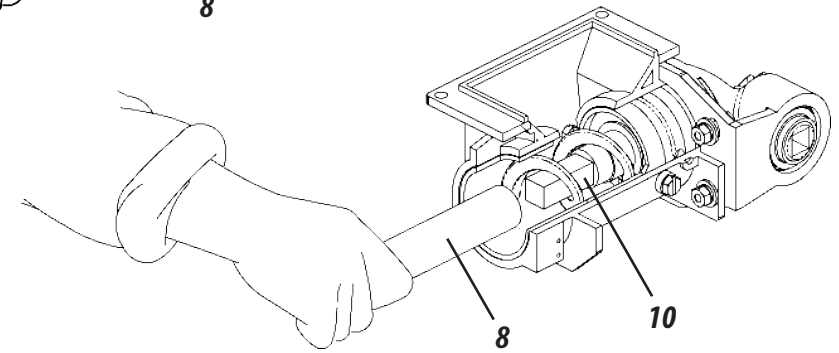
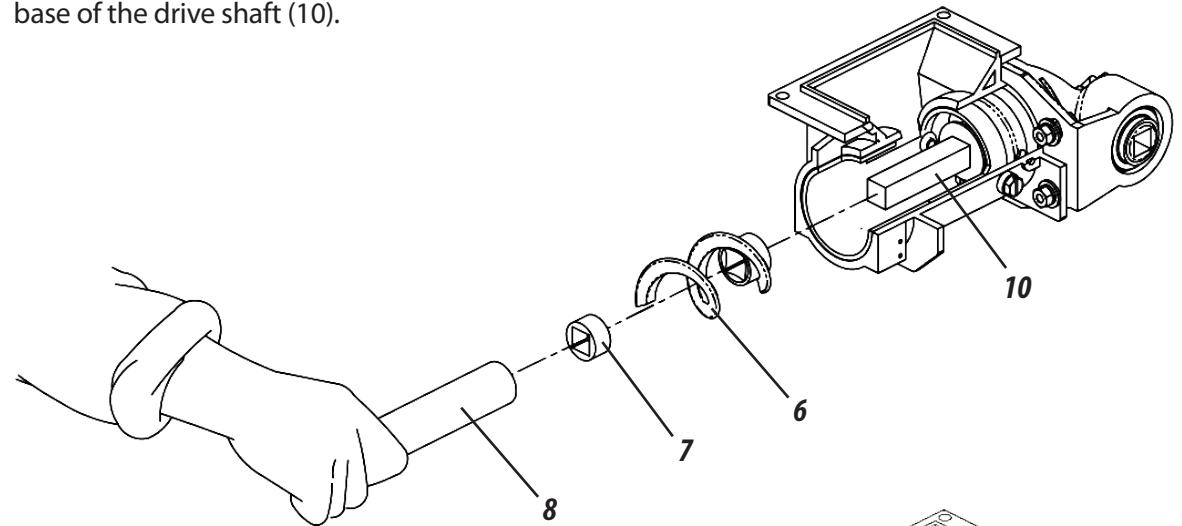

### ⚠ ATTENTION

*Keep the endless spring in place with the locking ring. This will avoid damaging the transverse cap when the seeder is not used with the fertilizer or when transporting the seeder. Failure of the locking ring can lead to damage of the fertilizer distribution and/or transmission of the seeder.*

**FERTISYSTEM CONDUCTOR MAINTENANCE TUBE**

The **SPDE CXP** seeder, when sold with the Fertisystem driver, comes with a maintenance tube (1) for maintenance or changing of the endless spring, without the need to remove the fertilizer from the tank.

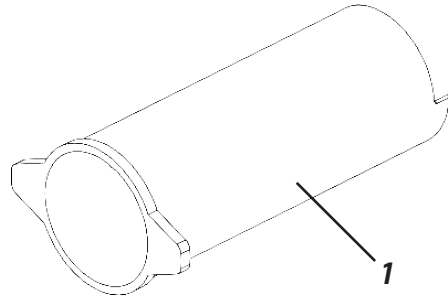

**Maintenance Tube**  
Code: 60203900930

To service the fertisystem driver, proceed as follows:

- 1- Remove the discharge nozzle (2) from the fertisystem driver (3), releasing the quick release (4).

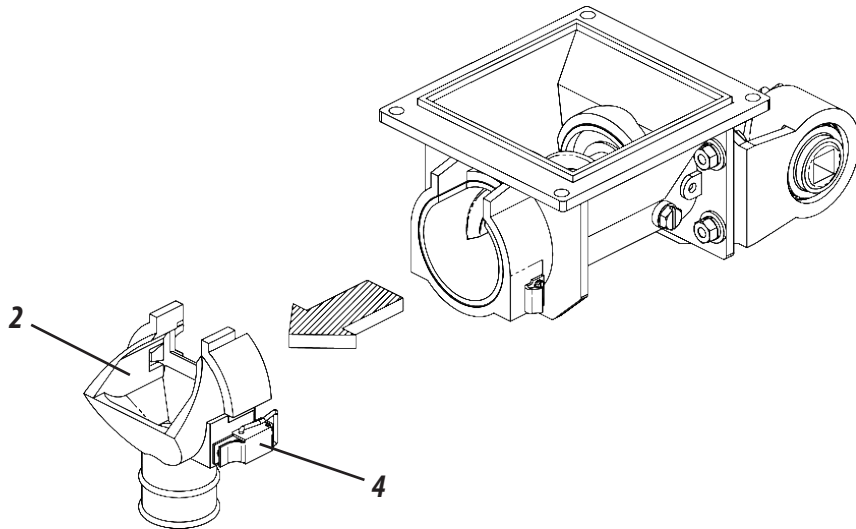

- 2- Then insert the maintenance tube (1) with rotating movements, promoting the movement of the fertilizer to the bottom of the doser. Then perform the necessary maintenance.

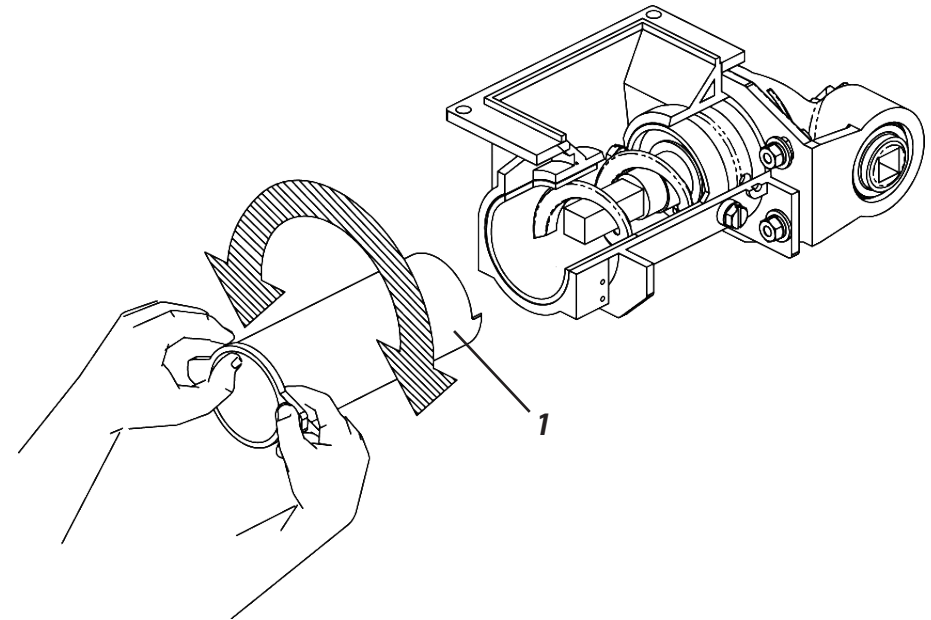
**NOTE**

*The maintenance tube (1) has a cutting angle at the end to facilitate this operation.*

**MAINTENANCE**

# MAINTENANCE

## FERTISYSTEM CONDUCTOR BLOCKING TUBE

The **SPDE CXP** seeder, when sold with the Fertisystem driver accompanies a blocking tube for when you need to isolate some planting lines, so that distribution of the fertilizer does not happen.

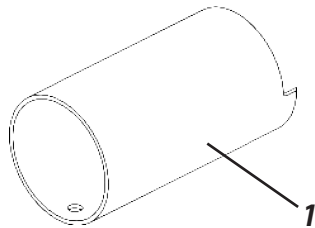

**Blocker Tube**  
Code: 60203900913

Then, remove the endless spring (5) and the locking ring (6) from the Fertisystem (3).

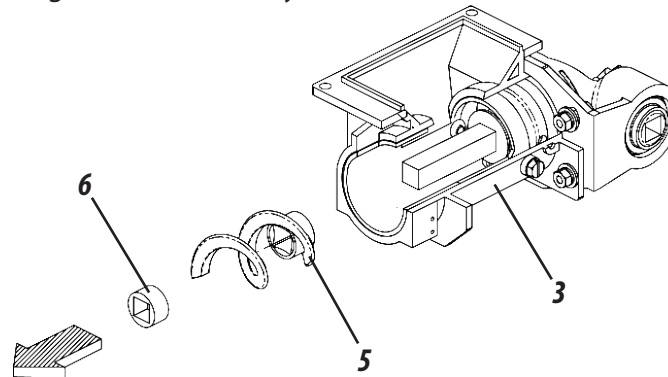

Then insert the release tube (1) and replace the discharge nozzle (2).

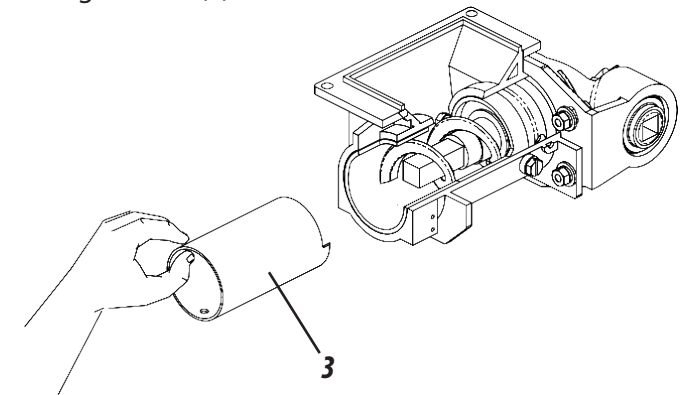

## SPRING AND CAPS (OPTIONAL) FERTISYSTEM DRIVER

The seeder **SPDE CXP** leaves the factory assembled with an endless spring of pitch 2", but the seeder has a pitch 1" endless spring in its packaging. The seeder can also be supplied with 3/4" pitch endless spring (**optional**).

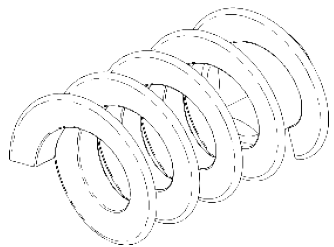

**Endless Spring (Pitch 3/4")**  
Code: 60203700418

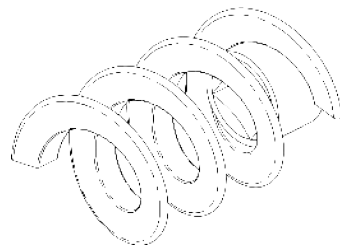

**Endless Spring (Pitch 1")**  
Code: 60203700426

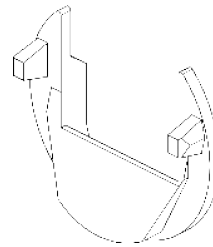

**Fertipó Cover**  
Code: 60203900530

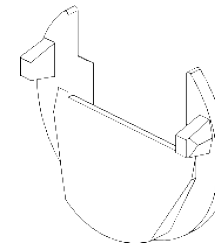

**High Flow Cap**  
Code: 60203900522

### NOTE

**Always fill the fertilizer tank at the work location.**  
**Avoid any kind of impurity inside of the fertilizer tank.**  
**Measure daily.**

The SPDE CXP seeder has options that can be purchased according to the need of work. Inside the options available are:

### CPL IRON COMPACTOR WHEEL CART

Item	Code	Description
01	51240105776	Heavy Iron Roller Cart Cpl Right
02	51240105784	Heavy Iron Roller Cart Cpl Left

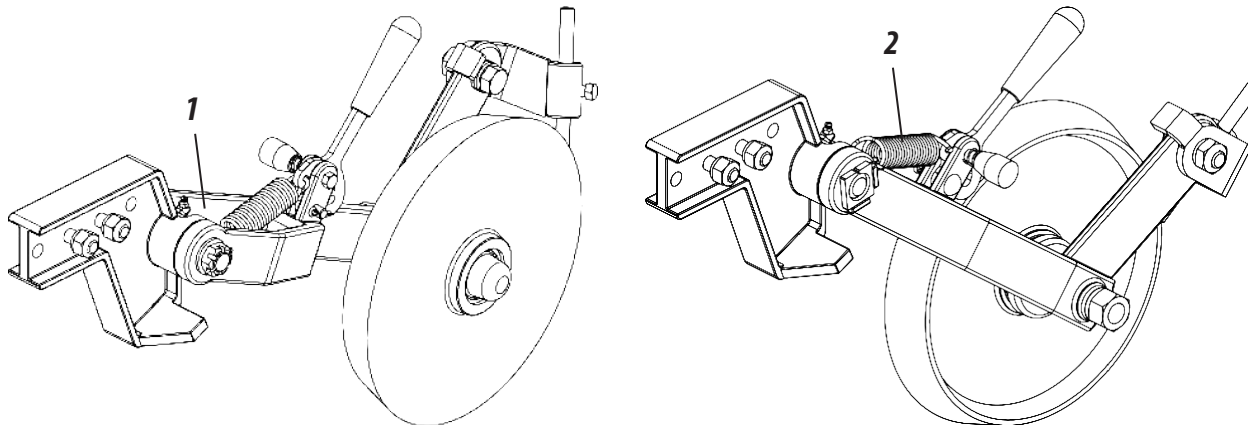

### CPL COMPACTOR WHEELS - OPTIONAL

Item	Code	Description
01	51240103781	Coller Cpl Concave Compactor Wheel
02	51240103790	Roller Cart Wheel Cpl Convex

Item	Code	Description
03	51240103803	Cpl Plain Roller Wheel Cart
04	51240103811	Roller Cart Wheel Cpl in "V"

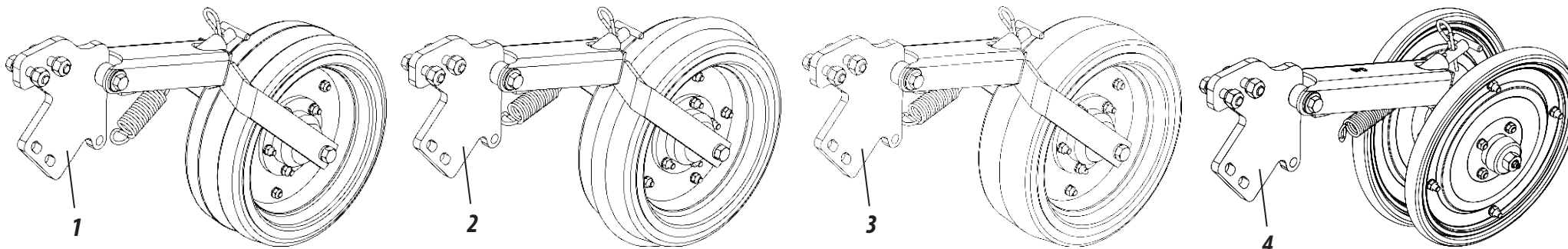

## OPTIONALS

# OPTIONALS

The **SPDE CXP** seeder has options that can be purchased according to the need of work. Inside the options available are:

## LIMITING FLANGE W/ CLEANER

Item	Code	Description
01	52880100564	Right Limiter Fitting (Depth 20mm)
02	52880100572	Left Limiting Finger (Depth 20mm)

Item	Code	Description
03	52880100548	Right Limiting Fitting (Depth 40mm)
04	52880100556	Left Limiting Fitting (Depth 40mm)

Item	Code	Description
05	52880100580	Right Limiting Fitting (Depth 55mm)
06	52880100599	Left Limiting Fitting (Depth 55mm)

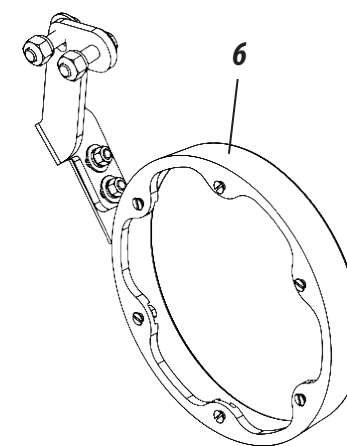
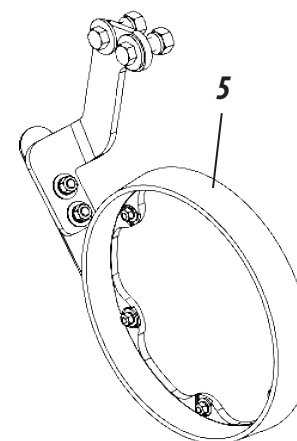
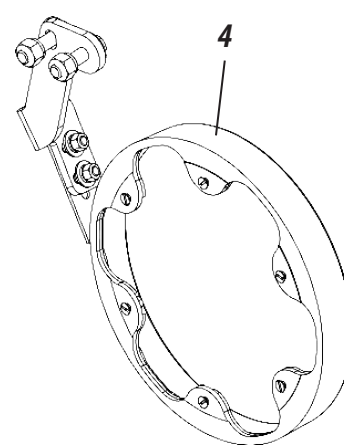
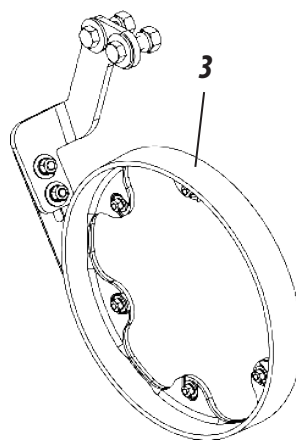
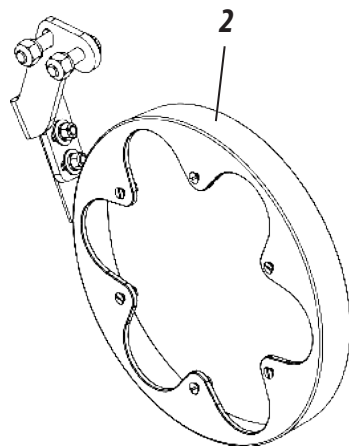
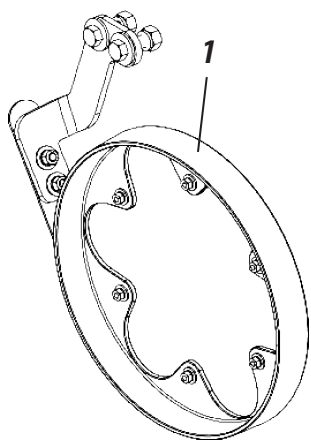

The **SPDE CXP** seeder has options that can be purchased according to the need of work. Inside the options available are:

### MECHANICAL SIDE TRANSPORT KIT

Models	Code
SPDE CXP 3000 / 4000 / 5000	50921337547

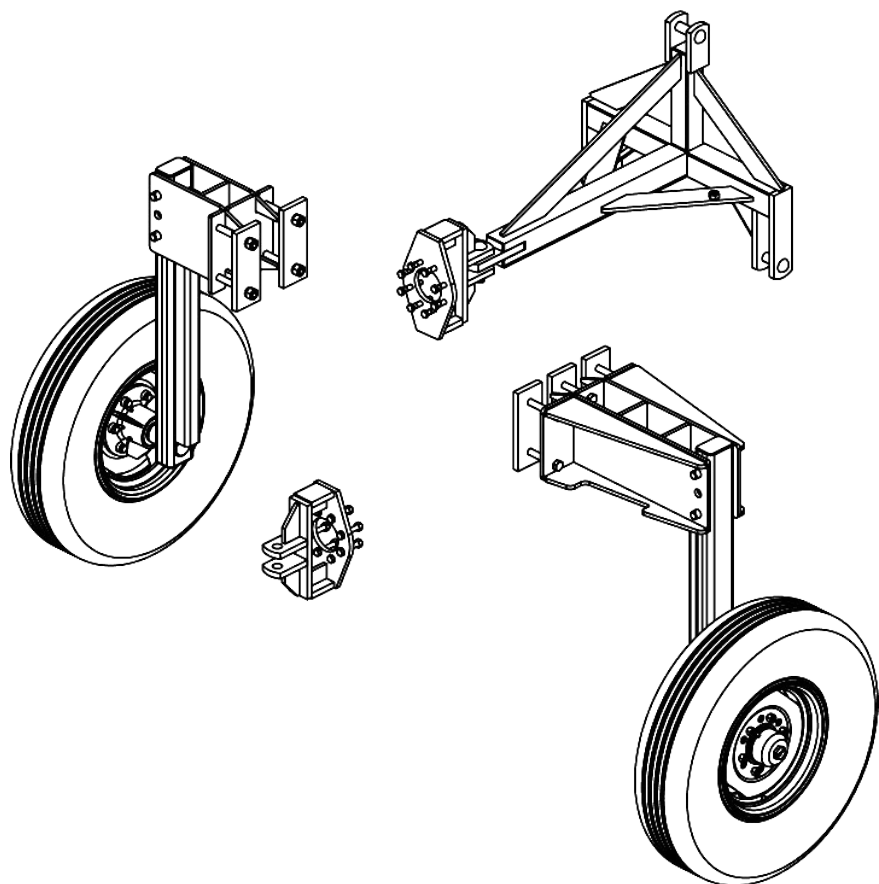

### HYDRAULIC SIDE TRANSPORT KIT

Models	Code
SPDE CXP 3000	50921339515
SPDE CXP 4000 / 5000	50921339523

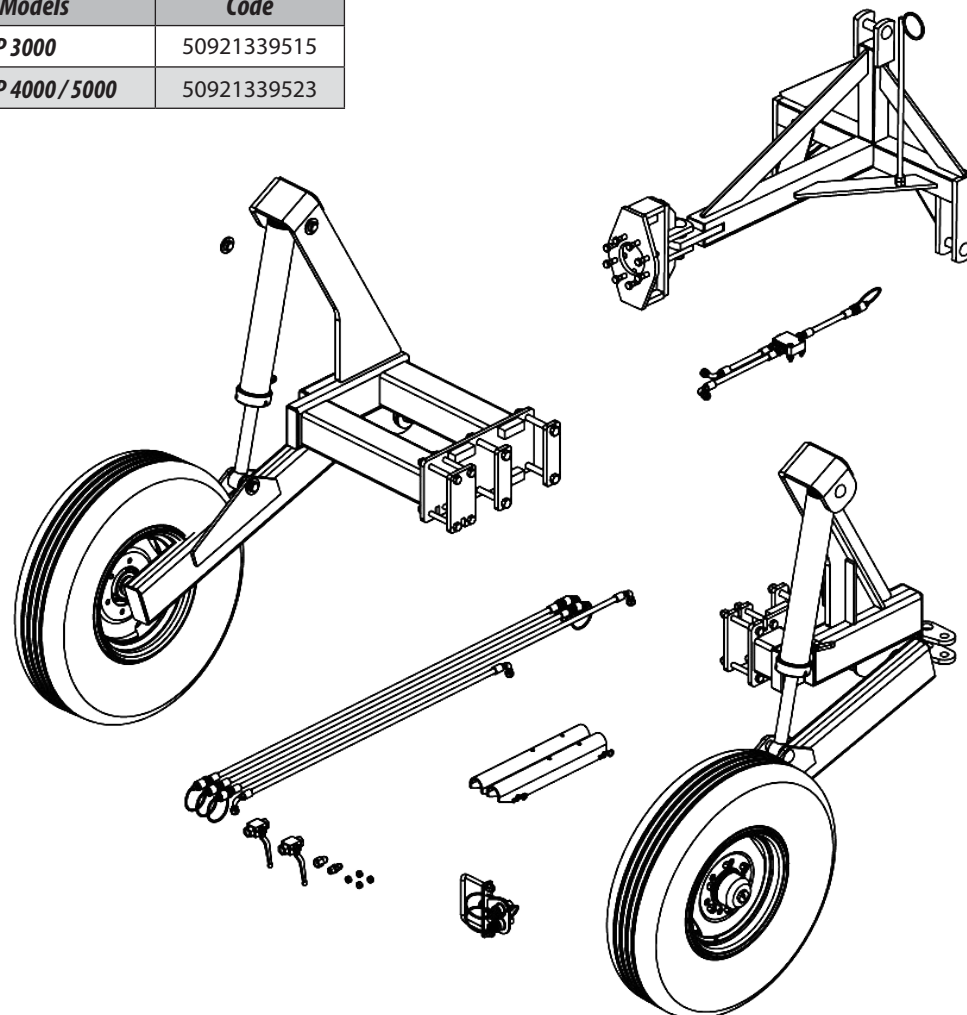

**OPTIONALS**

## OPTIONALS

The **SPDE CXP** seeder has options that can be purchased according to the need of work. Inside the options available are:

### FINE SEEDS CPL BOX

Models	Description	Code
<i>SPDE CXP 3000</i>	Unique	50920104204

Models	Description	Codes
<i>SPDE CXP 4000</i>	Right	50920104298
<i>SPDE CXP 4000</i>	Left	50920104301

Models	Description	Codes
<i>SPDE CXP 5000</i>	Right	50920104336
<i>SPDE CXP 5000</i>	Left	50920104344

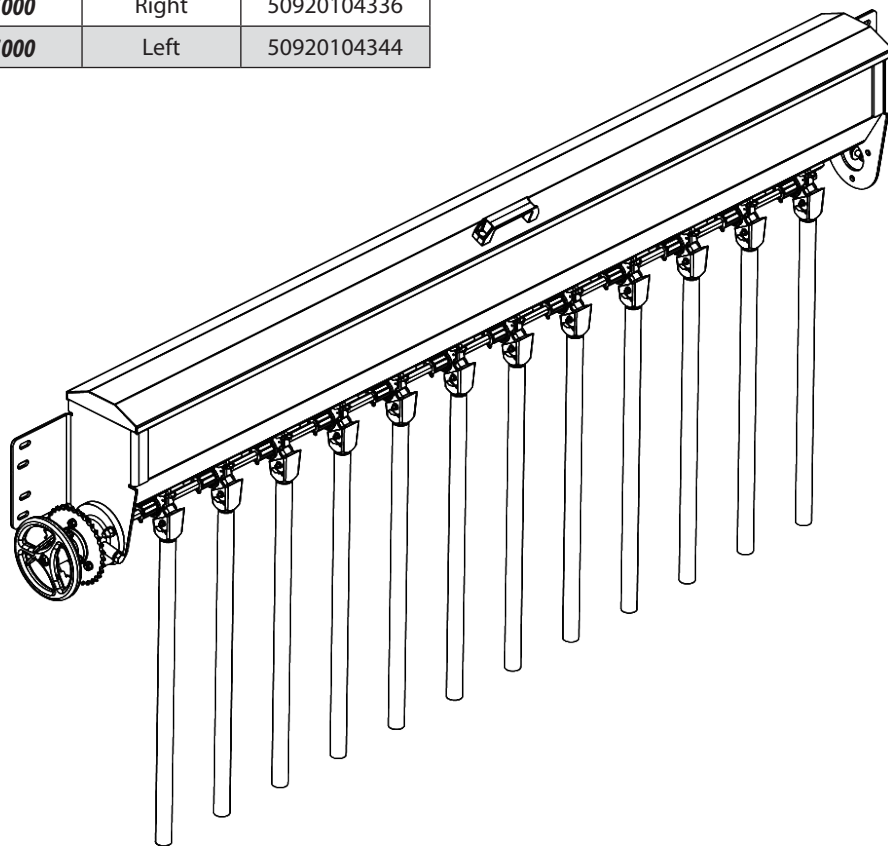

### CPL LINE MARKER SYSTEM W/ STEERING

Models	Codes
<i>SPDE CXP 3000</i>	55280103925
<i>SPDE CXP 4000</i>	55280103933
<i>SPDE CXP 5000</i>	55280103941

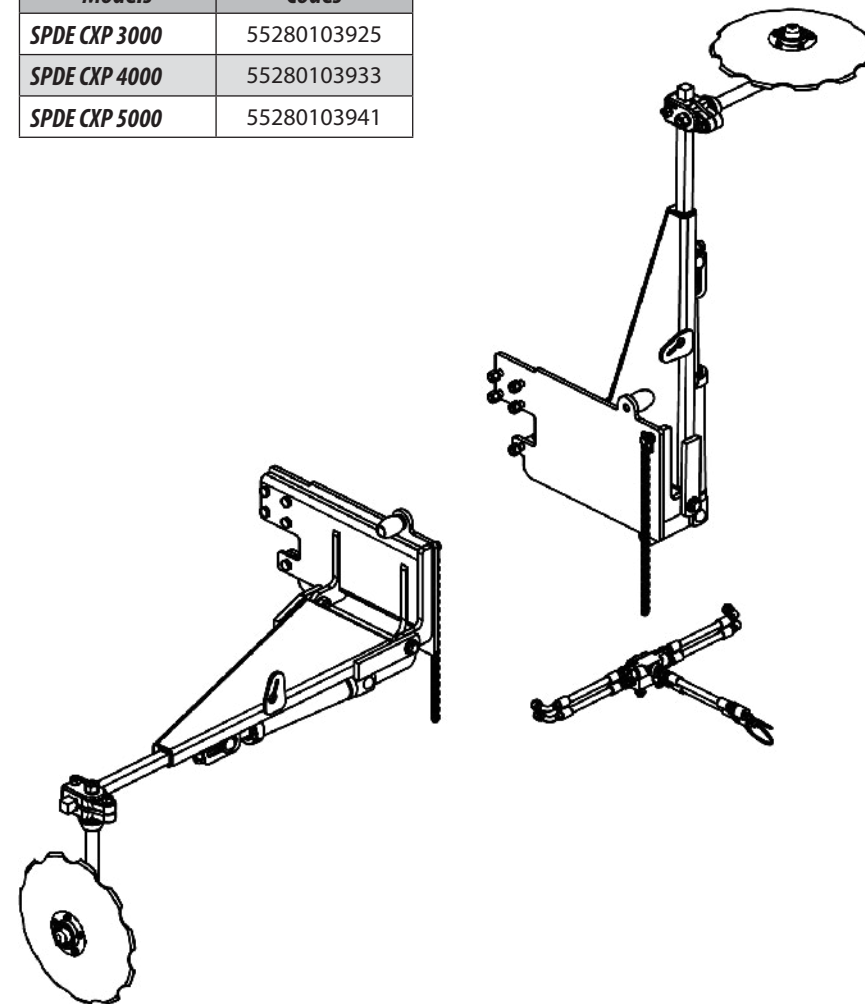

The **SPDE CXP** seeder has options that can be purchased according to the need for work. Within the options available are:

### ETD SYSTEM (ELECTRONIC DOSING TABLE)

**SPDE CXP** can be purchased optionally with the **ETD** (Electronic Dosing Table) system. The **ETD** is an electronic device that can be connected to planters, seeders and fertilizers to assist the operator in setting the best gear ratio so that the correct dosage of seeds and fertilizers occurs, according to the needs of each area / plot, based on the adjustments previously done in the field and calibrations before planting. It allows to perform other additional functions such as the registration of planted hectares, hours actually worked and planting speeds above specified, and this important information is recorded and shown on the **ETD** electronic device display.

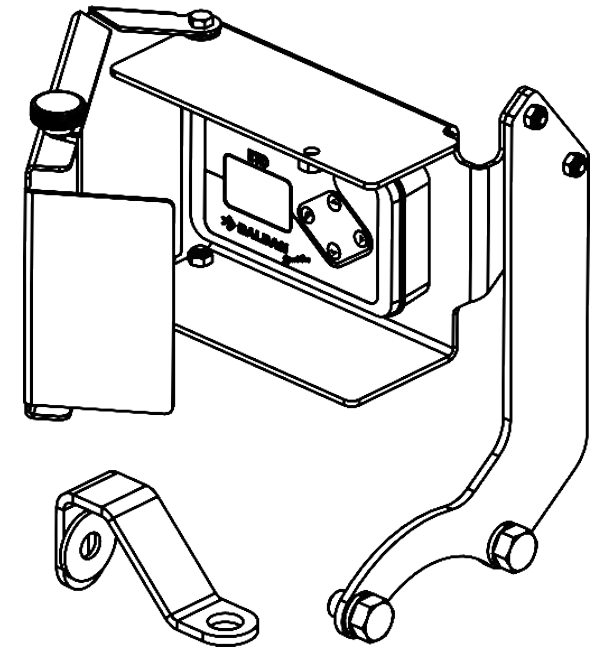

*ETD (ELECTRONIC DOSING TABLE)*



## **ATTENTION**

*To use the ETD (Electronic Dosing Table), refer to the instruction manual on the following pages.*

# ETD MANUAL

## OPERATION MANUAL ETD (ELECTRONIC DOSING TABLE) - OPTIONAL

### • Presentation



The **ETD** is an electronic device that can be connected to planters, seeders and fertilizers to assist the operator in setting the best gear ratio so that the correct dosage of seeds and fertilizers occurs, according to the needs of each area / plot, based on the adjustments previously done in the field and calibrations before planting. It allows to perform other additional functions such as the registration of planted hectares, hours actually worked and planting speeds above specified, and this important information is recorded and shown on the **ETD** electronic device display.

**OPERATION MANUAL ETD (ELECTRONIC DOSING TABLE) - OPTIONAL****• Mounting the magnets on the main axis**

The magnets (1) must be installed on the planter's primary axis, after the shutdown ratchet, as this will not count hours and hectares when the machine is in transport. A magnet must be installed on each face of the shaft (3), securing them with two nylon clamps (4) so that they are properly fixed and positioned (4).

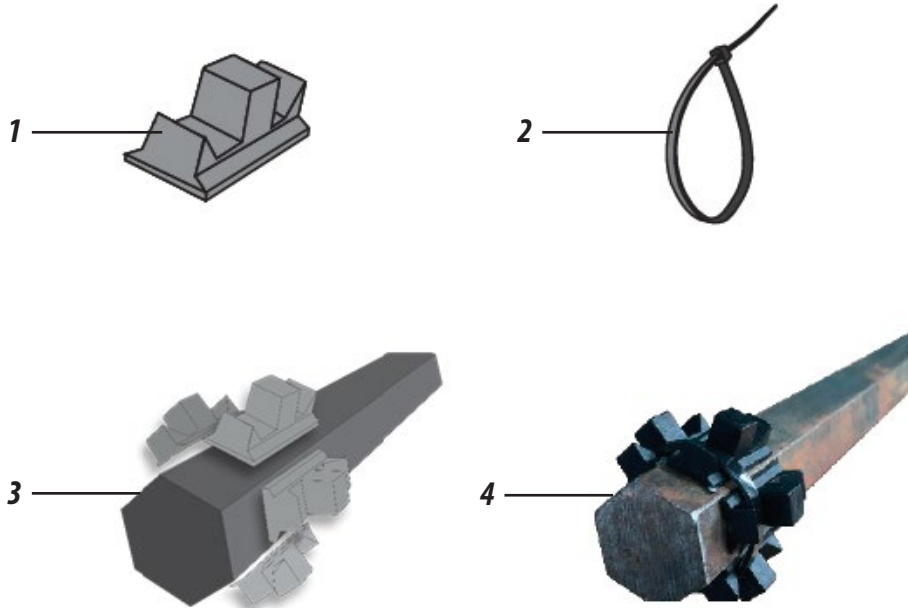
**• Mounting the speed sensor**

Mount the sensor (1) on the support (2) fixing by the nuts (3) according to the image (4).

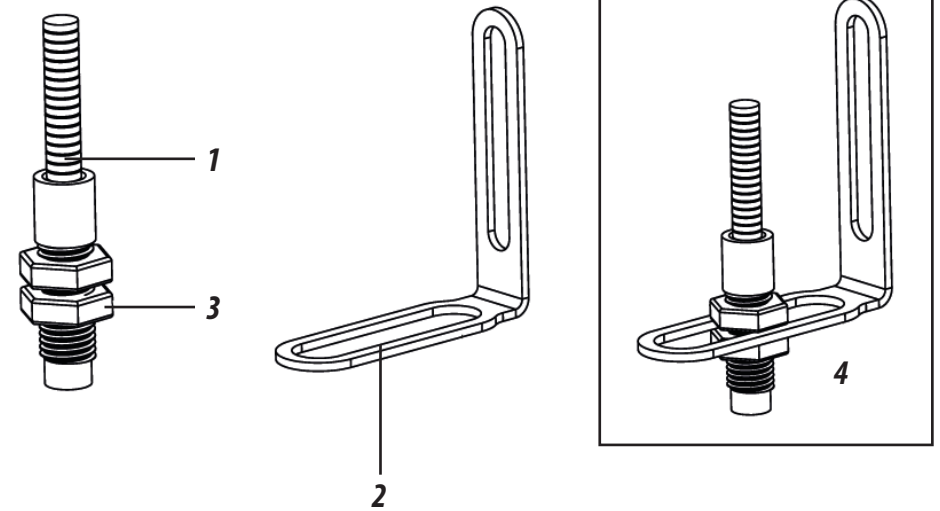

## OPERATION MANUAL ETD (ELECTRONIC DOSING TABLE) - OPTIONAL

### • Speed sensor installation

Attach the sensor support (1) to the machine chassis (2) using the M8x30 screw (3) making sure that the distance between the sensor and the magnets is less than 3 mm (4). It is extremely important to align the speed sensor and the magnets on the primary axis (5).

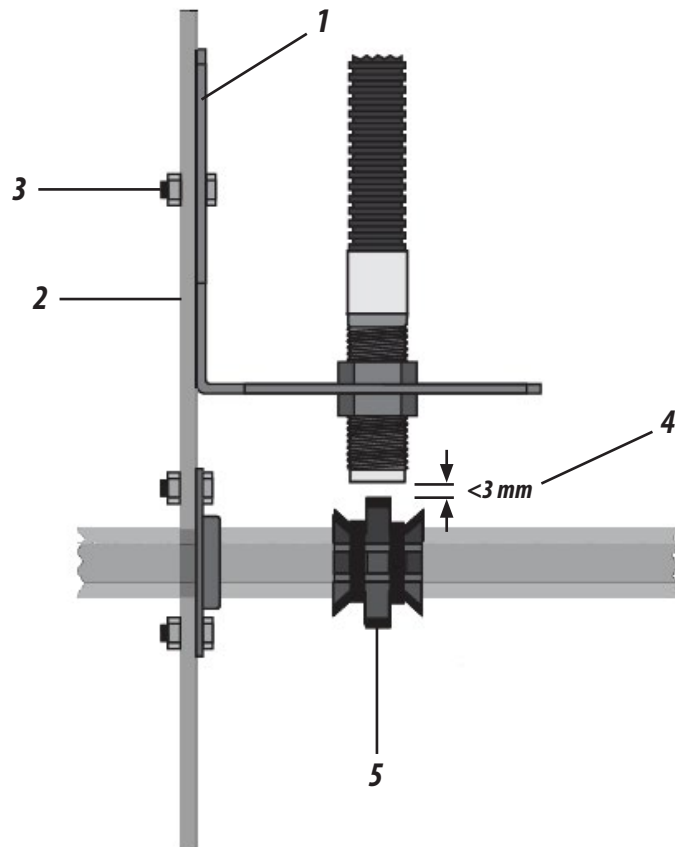

### • Identification



- A - Display
- B - Function key
- C - Decrease item
- D - Enter
- E - Increase item

#### The ETD has four keys

##### Function key F

The Function key F is used to change between the four main functions of the ETD, which are:

- F1: Seed rate
- F2: Fertilizer rate
- F3: Hour meter
- F4: Hectometer

Within the menus, the Function F key assumes the “back” function, which facilitates navigation.

#### Keys

The ▼ and ▲ keys are used to increase or decrease numeric items in the interface. The icon with arrows above and below the interface indicates the item to be controlled by the keys.



#### Keys ▶

The key ▶ is used as a “enter” function. This key allows you to enter the options that are shown in the lower right corner of the interface.

OPERATION MANUAL ETD (ELECTRONIC DOSING TABLE) - OPTIONAL

• **Settings menu**

The settings menu (1) can be accessed through the Function key F, when pressed for more than 2 seconds.

The settings menu has 7 items. The keys  (2) are used to navigate between menu items.



The Select key.  (3) is used to select the highlighted item. Just click on the "F" key (4) to exit the settings menu.

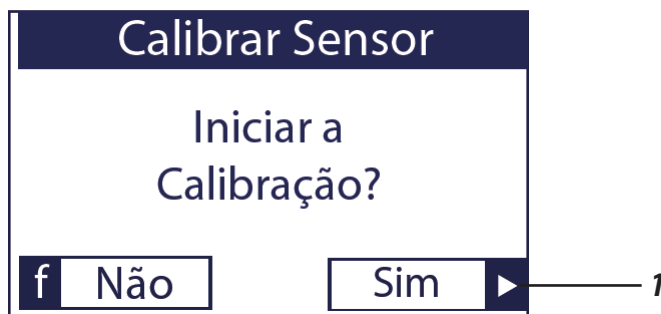

To select the start of the calibration click 'Yes'  (1).

• **Sensor calibration**



When starting the sensor calibration (2), the machine must be moved for exactly 100 meters (3) and stopped.

The number of pulses (4) counted by the sensor is shown on the screen. To complete the calibration, the operator must press the  (5) "Ready" key.

The calibration of the sensor is important for the ETD to determine the number of hectares worked, the working speed of the machine and also the distance covered in the fertilizer calibration.

If, during displacement, the number of pulses corresponding to the end of the 100m is not displayed, the displacement of the sensor or magnets may have occurred, making it impossible to read the pulses during the displacement. In this case, it is necessary to adjust these components according to the assembly diagram, item 4 "INSTALLING THE SPEED SENSOR", previous page.

## OPERATION MANUAL ETD (ELECTRONIC DOSING TABLE) - OPTIONAL

### • Machine

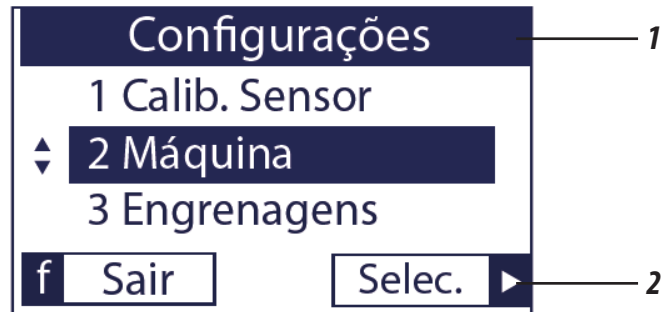

In the machine configuration (1), click on 'Select' ► (2) to inform the number of lines using the buttons ▲▼ (3).



Number of lines, range of values: 01 ~ 80.

After selecting the number of lines contained in the machine, press the 'Prox' ► key (4) to select the line spacing using the buttons ▲▼ (5).

### • Sensor machine



When clicking on "Save" ► (6), the system saves the settings and displays the following message.



This information is very important for the presentation of the worked hectares and also for the calibration of fertilizer rates.

OPERATION MANUAL ETD (ELECTRONIC DOSING TABLE) - OPTIONAL

• Seed rate

The **Seed Rate** function is not used in fine grain seeders.

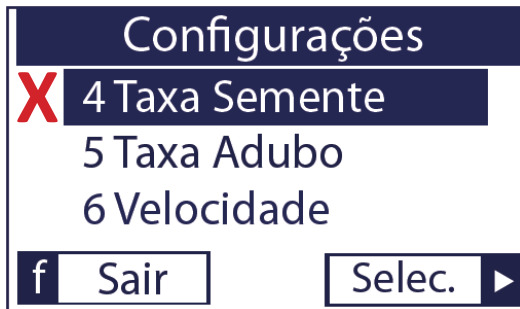

• Fertilizer rate - Part I

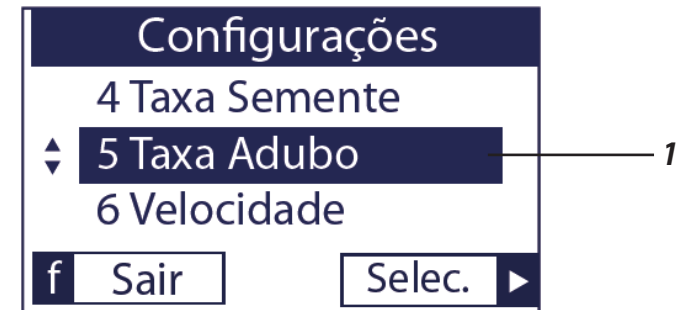

Screen F2 (1) indicates the fertilizer rate (2) in kg per hectare obtained with a specific gear ratio. Fertilizer rates are calculated according to the fertilizer calibration, the gear configuration (3) and the line spacing. The keys ▼ and ▲ (4) allow the user to navigate between the rate options in Kg / ha.

Fertilizer rate: ETD

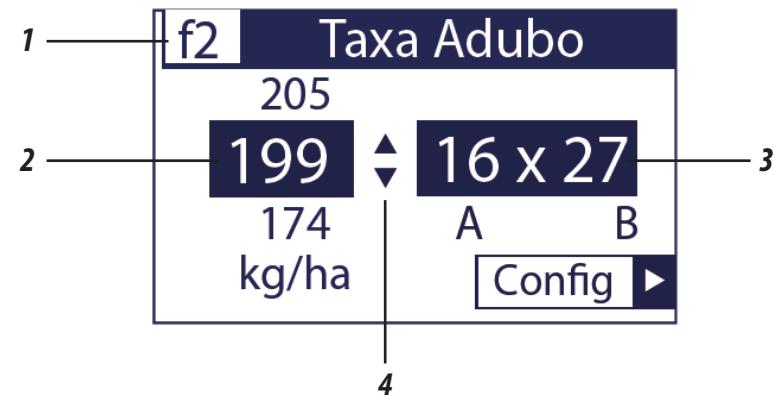

## OPERATION MANUAL ETD (ELECTRONIC DOSING TABLE) - OPTIONAL

### • Fertilizer rate - Part II

The fertilizer rate menu has two items: Total Calculation (5) and Calibrate Fertilizer (6).

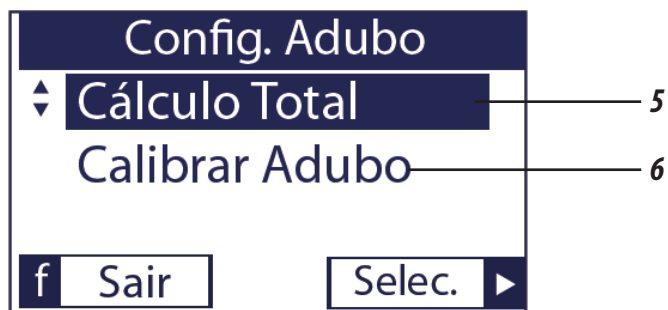

### • Total calculation

In total calculation (5), the user can calculate the amount of total fertilizer in tons (8) required for planting a certain area, in hectares. The last fertilizer rate selected on the F2 function screen (9), selected using the key ▲ (10) is used as a reference for the calculation.



### • Calibrate fertilizer - Part I

The fertilizer calibration (11) has 3 steps. First, you must inform the gear ratio (12) used on the machine at the time of calibration. **EXAMPLE:** In the SPEED BOX, configure the option Mot 6 and Mov F, then enter the same configuration in the ETD; then walk 50 m collecting at least 3 fertilizer outlets, make the average and enter the value in the electronic table).

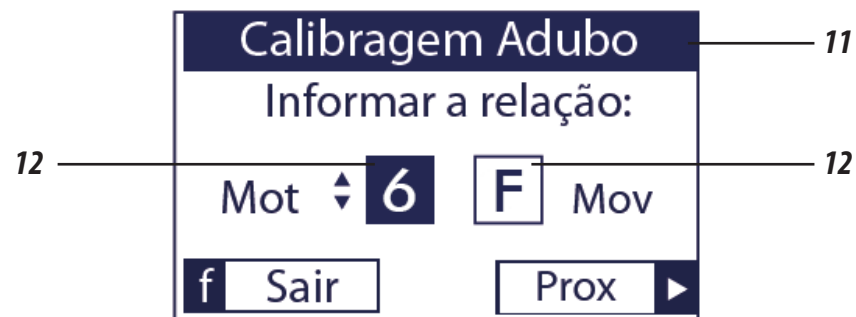

**OPERATION MANUAL ETD (ELECTRONIC DOSING TABLE) - OPTIONAL****• Calibrate fertilizer - Part I**

On the next screen, the operator must walk with the machine collecting the fertilizer over a distance greater than 50 meters (1). It is important that the sensor is already calibrated so that the distance covered is measured correctly. The distance traveled is displayed instantly (2).

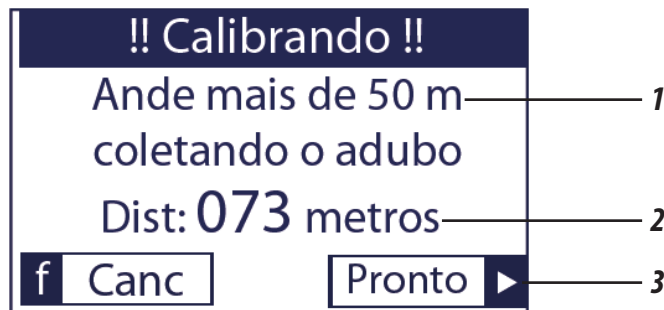

After covering the required distance, click on Ready (3).

**NOTE:** The minimum distance to be covered is 50 meters, if this distance is insufficient, the screen for entering the weight of the collection will not be enabled and the following warning will be displayed:

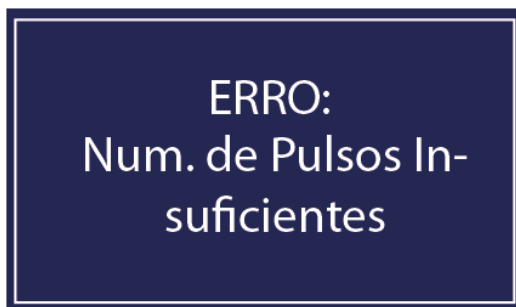

On the next screen (1), the total weight of the collected fertilizer (2) in a row or the average of the collection, always in grams, is reported.

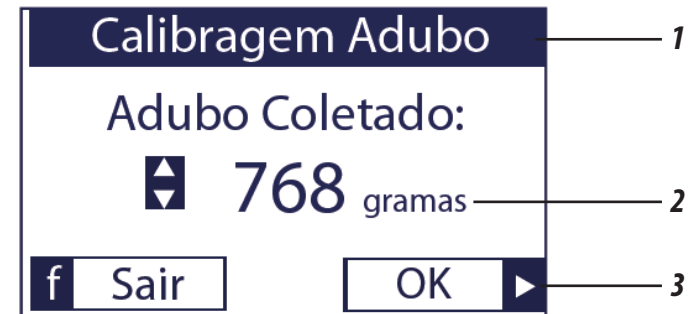

Compost collected, range of values: 10 ~ 9000 grams.

Clicking 'OK' (3) the 'calibration complete' message is displayed.

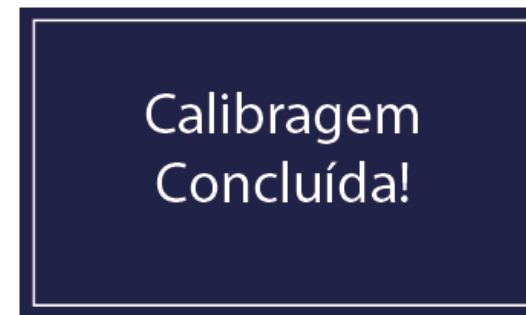

# ETD MANUAL

## OPERATION MANUAL ETD (ELECTRONIC DOSING TABLE) - OPTIONAL

### • F3 Hour meter

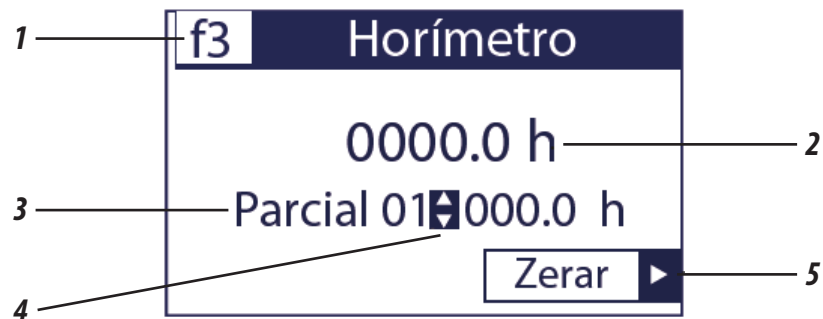



The F3 screen (1) indicates the total number of hours (2) of work with the ETD in three partials (3), which can be related to the keys  (4).

To reset a certain partial, the Reset key (5) must be held down for more than 2 seconds.

The hours counted refer only to the time that the machine was in effective work, that is, with the ratchet on. Thus, hours of handling the ETD or traveling with the machine in the transport position will not be counted.

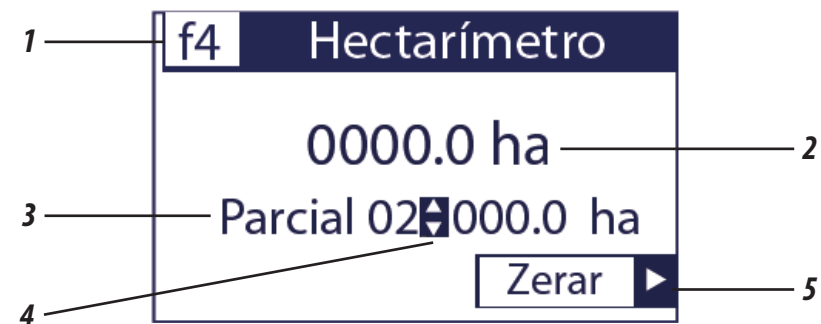
### • F4 Hectometer



Screen F4 (1) indicates the total number of hectares worked (2) with the ETD, also in 3 partial ones (3), which can be selected using the keys  (4).

**OPERATION MANUAL ETD (ELECTRONIC DOSING TABLE) - OPTIONAL****• Settings menu**

The settings menu (1) can be accessed through the Function key F, when pressed for more than 2 seconds.

The settings menu has 7 items. The keys  (2) are used to navigate between menu items.



The Select key.  (3) is used to select the highlighted item. Just click on the "F" key (4) to exit the settings menu.



To select the start of the calibration click 'Yes'  (1).

**• Sensor calibration - Part I**

When starting the sensor calibration (2), the machine must be moved for exactly 100 meters (3) and stopped.

## OPERATION MANUAL ETD (ELECTRONIC DOSING TABLE) - OPTIONAL

### • Sensor calibration - Part II

The number of pulses (4) counted by the sensor is shown on the screen. To complete the calibration, the operator must press the ► (5) "Ready" key.

The calibration of the sensor is important for the ETD to determine the number of hectares worked, the working speed of the machine and also the distance covered in the fertilizer calibration.

If, during displacement, the number of pulses corresponding to the end of the 100m is not displayed, the displacement of the sensor or magnets may have occurred, making it impossible to read the pulses during the displacement. In this case, it is necessary to carry out the adjustment of these components according to the assembly diagram, item 4 "INSTALLING THE SPEED SENSOR", page 81.

### • Machine - Part I

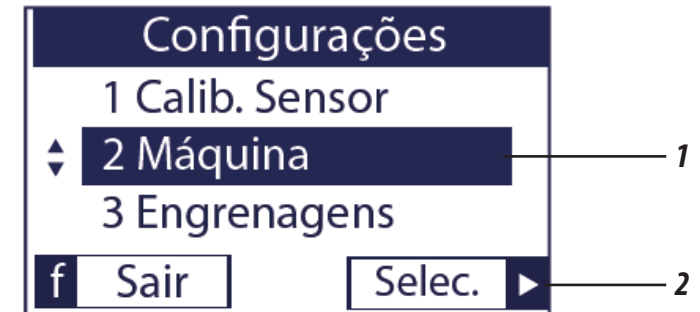

In the machine configuration (1), click on 'Selec.' (2) to inform the number of lines using the buttons ▲▼ (3).

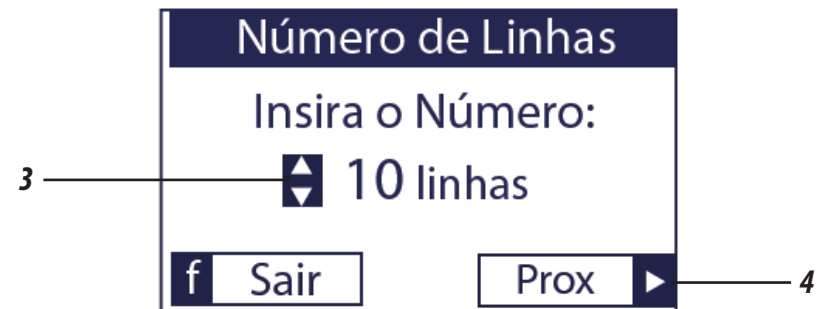

Number of lines, range of values: 01 ~ 80.

After selecting the number of lines contained in the machine, press the 'Prox' ► key (4) to select the line spacing using the buttons ▲▼ (5).

**OPERATION MANUAL ETD (ELECTRONIC DOSING TABLE) - OPTIONAL**• **Machine - Part II**

Espaçamento, faixa de valores: 01 ~ 99 cm.

When clicking on "Save" ► (6), the system saves the settings and displays the following message.

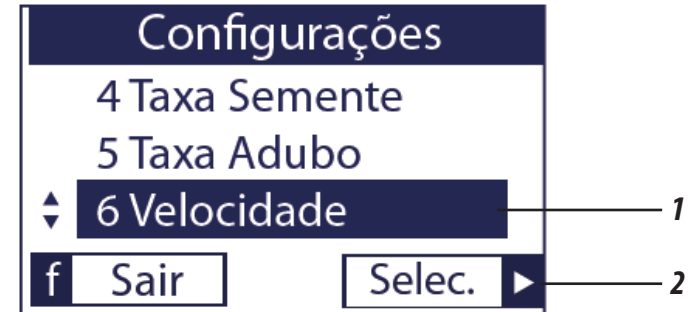

This information is very important for the presentation of the worked hectares and also for the calibration of fertilizer rates.

• **Time above maximum speed**

Clicking on 'Select.' ► (2) in the 'Speed' setting (1) will show how many hours (4) the machine has been working above the limit speed (3).

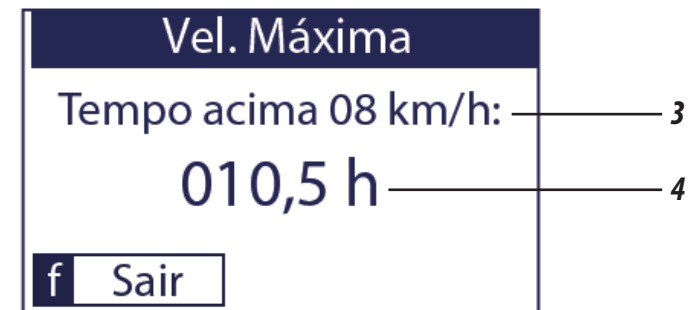

# IDENTIFICATION

## PRODUCT IDENTIFICATION

- 1- In order to consult the parts catalog or to request technical assistance from Baldan, always identify the model (1), serial number (2) and date of manufacture (3), which is located on the identification label (4) of the seeder.
- 2- **ALWAYS DEMAND ORIGINAL BALDAN PARTS.**

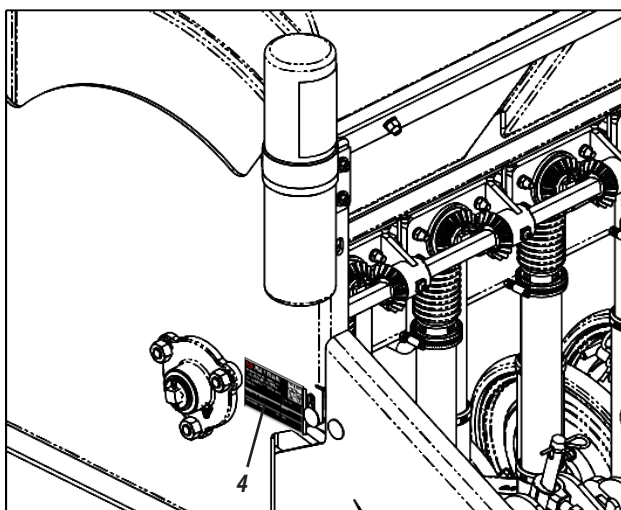

Make identification of the data below to always have accurate information about the life of your seeder.

Owner: \_\_\_\_\_

Reseller: \_\_\_\_\_

Farm: \_\_\_\_\_

City: \_\_\_\_\_ State: \_\_\_\_\_

Nº Certificado Garantia: \_\_\_\_\_

Model: \_\_\_\_\_

Serial No.: \_\_\_\_\_

Date of purchase: \_\_\_\_\_ Invoice. No.: \_\_\_\_\_

## ATTENTION

*The drawings in this manual are merely illustrative. To enable better vision and detailed instruction, some drawings in this manual, safety devices (covers, protections, etc.) have been removed. Never operate the seeder without these devices.*



**PUBLICATIONS**

Code: 60550106178  
CPT: SPDECXP13321A



**CONTACT**

*In case of doubt, consult the After Sales Service.*  
Phone: 0800-152577  
E-mail: posvenda@baldan.com.br





## WARRANTY CERTIFICATE

**BALDAN IMPLEMENTOS AGRÍCOLAS S/A**, ensures normal operation of the implement to the dealer for a period of six (6) months from the delivery date on the resale invoice to the first end consumer.

During this period undertakes **BALDAN** to remedy defects in materials and/or workmanship of their responsibility, and the labour, freight and other expenses are of the responsibility of the dealer.

During the warranty period, the order and replacement of any defective parts must be made to the dealer in the region, who will send the defective part for analysis at **BALDAN**. When such a procedure is not possible and exhausted the resolution capacity of the dealer, the dealer will request support from the Technical Assistance of **BALDAN**, through the specific form distributed to resellers.

After analysing the items replaced by the Technical Assistance of Baldan, and concluded that it is not a warranty issue, so it will be of responsibility of the reseller any costs related to replacement; as well as the cost of materials, travel including accommodation and meals, accessories, lubricant and other expenses resulting from the call to the service, with the Baldan company authorised to make its billing on behalf of the reseller.

Any repairs made to the product that is within the warranty period of the dealer will only be authorized by **BALDAN** with prior presentation of the budget describing the work of parts and labor to be performed.

It is excluded from this term the product that is repaired or modified in shops that do not belong to the dealer network of **BALDAN**, as well as the use of non-genuine parts or components in the product of the customer.

This guarantee will be void when it is determined that the defect or damage is the result of improper product use, failure to follow instructions or the inexperience of the operator.

It is agreed that this warranty does not cover tires, polyethylene tanks, driveshafts, hydraulic components, etc., which is equipment guaranteed by their manufacturers.

Manufacturing and or material defects, object of this warranty term, will not constitute, under any circumstances, a reason for termination of the purchase and sale contract or compensation of any nature.

**BALDAN** reserves the right to modify and or improve the technical characteristics of its products without notice and without obligation so to proceed with the products previously manufactured.

## INSPECTION AND DELIVERY CERTIFICATE

- **SERVICE BEFORE DELIVERY:** This implement was carefully prepared by the sales organisation, checked in all its parts according to the manufacturer's instructions.
- **DELIVERY SERVICE:** The user is informed about the terms of existing warranty and instructed on the use and maintenance care.
- I confirm that I was informed about the current guarantee terms and instructed about the use and proper maintenance of the implement.

Tool: \_\_\_\_\_

Serial Number: \_\_\_\_\_

Date: \_\_\_\_\_ Invoice No: \_\_\_\_\_

Reseller: \_\_\_\_\_ City: \_\_\_\_\_

State: \_\_\_\_\_ Zip Code: \_\_\_\_\_

Owner: \_\_\_\_\_ Phone: \_\_\_\_\_

Address: \_\_\_\_\_ Number: \_\_\_\_\_

City: \_\_\_\_\_ State: \_\_\_\_\_

E-mail: \_\_\_\_\_

Sale Date: \_\_\_\_\_

Signature / Reseller Stamp \_\_\_\_\_

1st - Owner

# CERTIFICATE

## INSPECTION AND DELIVERY CERTIFICATE

- **SERVICE BEFORE DELIVERY:** This implement was carefully prepared by the sales organisation, checked in all its parts according to the manufacturer's instructions.
- **DELIVERY SERVICE:** The user is informed about the terms of existing warranty and instructed on the use and maintenance care.
- I confirm that I was informed about the current guarantee terms and instructed about the use and proper maintenance of the implement.

Tool: \_\_\_\_\_

Serial Number: \_\_\_\_\_

Date: \_\_\_\_\_ Invoice No: \_\_\_\_\_

Reseller: \_\_\_\_\_ City: \_\_\_\_\_

State: \_\_\_\_\_ Zip Code: \_\_\_\_\_

Owner: \_\_\_\_\_ Phone: \_\_\_\_\_

Address: \_\_\_\_\_ Number: \_\_\_\_\_

City: \_\_\_\_\_ State: \_\_\_\_\_

E-mail: \_\_\_\_\_

Sale Date: \_\_\_\_\_

Signature / Reseller Stamp \_\_\_\_\_

2nd - Reseller

## INSPECTION AND DELIVERY CERTIFICATE

- **SERVICE BEFORE DELIVERY:** This implement was carefully prepared by the sales organisation, checked in all its parts according to the manufacturer's instructions.
- **DELIVERY SERVICE:** The user is informed about the terms of existing warranty and instructed on the use and maintenance care.
- I confirm that I was informed about the current guarantee terms and instructed about the use and proper maintenance of the implement.

Tool: \_\_\_\_\_

Serial Number: \_\_\_\_\_

Date: \_\_\_\_\_ Invoice No: \_\_\_\_\_

Reseller: \_\_\_\_\_ City: \_\_\_\_\_

State: \_\_\_\_\_ Zip Code: \_\_\_\_\_

Owner: \_\_\_\_\_ Phone: \_\_\_\_\_

Address: \_\_\_\_\_ Number: \_\_\_\_\_

City: \_\_\_\_\_ State: \_\_\_\_\_

E-mail: \_\_\_\_\_

Sale Date: \_\_\_\_\_

Signature / Reseller Stamp \_\_\_\_\_

3rd - Reseller

Please send this copy filled within 15 days to **BALDAN**.

**BALDAN IMPLEMENTOS AGRÍCOLAS S/A.**  
Av. Baldan, 1500 | Nova Matão | CEP: 15993-900 | Matão-SP | Brasil  
Phone: (0\*\*16) 3221-6500 | Fax: (0\*\*16) 3382-6500  
Home Page: [www.baldan.com.br](http://www.baldan.com.br) | e-mail: [sac@baldan.com.br](mailto:sac@baldan.com.br)  
Export: Phone: 55 16 3321-6500 | Fax: 55 16 3382-4212 | 3382-2480  
e-mail: [export@baldan.com.br](mailto:export@baldan.com.br)



THE STAMP WILL BE PAID BY:

**RESPONSE CARD**  
NO STAMPING IS REQUIRED

1.74.05.0059-5  
AC MATÃO  
ECT/DR/SP





Avenida Baldan, 1500  
Nova Matão  
15.993-900  
Matão/SP - Brasil  
sac@baldan.com.br  
export@baldan.com.br

+55 16 3221 6500  
[baldan.com.br](http://baldan.com.br)