

Instruction Manual



DCF-CO

Lime, Fertilizer and Organic Fertilizer Spreader

 **BALDAN**

■ Presentation

We appreciate the preference and would like to congratulate you for the excellent choice you just made, since you have acquired a product manufactured with **BALDAN**



IMPLEMENTOS AGRÍCOLAS S/A technology.

This manual will guide you through the procedures required since its acquisition until operational procedures of usage, safety and maintenance.

BALDAN assures that it has delivered this implement for resale in full and in perfect conditions.

Resale was responsible for the custody and maintenance during the period in its possession, and also for the assembly, retightening, lubrication and overhaul.

During the technical delivery, dealer should guide the user regarding maintenance, safety, their obligations in eventual technical assistance, strict compliance with the warranty term and reading the instructions manual.

Any technical assistance request while in warranty should be made to the dealer from whom you have purchased it.

We reiterate the need for a careful read of the warranty certificate and compliance of all items from this manual, because by doing so you will increase the life of your device.

Instruction Manual



DCF-CO

Lime, Fertilizer and Organic Fertilizer Spreader

BALDAN IMPLEMENTOS AGRÍCOLAS S/A.
CNPJ: 52.311.347/0009-06
Insc. Est.: 441.016.953.110



Scan the QR Code on the identification plate of your device and access this Instruction Manual online.

 **BALDAN**

▪ Index

BALDAN WARRANTY	07
GENERAL INFORMATION	08
<i>To the owner</i>	08
SAFETY RULES.....	09
<i>To the operator.....</i>	09 - 14
WARNINGS	15 - 16
COMPONENTS.....	17
<i>DCF-CO - Lime, Fertilizer and Organic Fertilizer Spreader (Cardan)</i>	17
<i>DCF-CO - Lime, Fertilizer and Organic Fertilizer Spreader (Hydraulic Engine)</i>	18
DIMENSIONS	19
<i>DCF-CO - Lime, Fertilizer and Organic Fertilizer Spreader</i>	19
SPECIFICATIONS	20
<i>DCF-CO - Lime, Fertilizer and Organic Fertilizer Spreader (Cardan and Hydraulic Engine) ...</i>	20
ASSEMBLY	21
<i>Assembling the tires</i>	21
<i>Assembling the driver box (Optional)</i>	22 - 23
<i>Assembling the canvas deflector (Optional)</i>	24 - 28
<i>Assembling the rubber deflector (Optional).....</i>	29 - 35
<i>Assembling the hydraulic system - DCF-CO 3000 (Hydraulic Engine).....</i>	36
<i>Assembling the hydraulic system - DCF-CO 6000/8000 (Hydraulic Engine)</i>	37
UNLOCKING	38
<i>Unlocking the wheelset pin</i>	38
HITCH.....	39
<i>Tractor hitch - DCF-CO (Cardan).....</i>	39
<i>Tractor hitch - DCF-CO (Hydraulic Engine).....</i>	40
<i>Support bracket.....</i>	41
LEVELING	42
<i>Leveling the distributor.....</i>	42
ADJUSTMENT	43
<i>Cardan coupling in the TDP - DCF-CO (Cardan)</i>	43
<i>Cardan length adjustment - DCF-CO (Cardan)</i>	44 - 45
ADJUSTMENTS	46
<i>Belt speed - DCF-CO (Cardan)</i>	46 - 47
<i>Belt speed - DCF-CO (Hydraulic Engine)</i>	48 - 49
<i>RPM calibration - DCF-CO (Hydraulic Engine).....</i>	50 - 51
<i>Belt tension.....</i>	52
<i>Belt tension.....</i>	53
<i>Belt tension</i>	54
<i>Belt replacement</i>	55
<i>Adjusting the gate</i>	56
<i>Position of fins in the distributor discs</i>	57
<i>Cardan Recommendations</i>	58
<i>Adjustment of guide plates (Optional)</i>	59

▪ Index

OPERATIONS.....	60
<i>Using the baffle</i>	<i>60</i>
<i>Distance between strokes.....</i>	<i>61</i>
<i>Overlapping.....</i>	<i>61</i>
<i>Working with the driver box (Optional)</i>	<i>62</i>
<i>Working with canvas or rubber baffle (Optional)</i>	<i>63</i>
<i>Transport with canvas or rubber baffle (Optional)</i>	<i>64</i>
<i>Recommendation for the operation</i>	<i>65</i>
<i>General recommendation</i>	<i>65 - 66</i>
CALCULATION.....	67
<i>Work speed calculation</i>	<i>67</i>
<i>Fertilizer dosage calculation per minute</i>	<i>67</i>
DISTRIBUTION SYSTEM.....	68
<i>Limestone distribution table - Kg/ha - DCF-CO (Cardan and Hydraulic Engine).....</i>	<i>68 - 72</i>
MAINTENANCE	73
<i>Tires pressure</i>	<i>73</i>
<i>Lubrification</i>	<i>74</i>
<i>Lubrification every 5 hours of work</i>	<i>75</i>
<i>Lubrification every 8 hours of work</i>	<i>76 - 78</i>
<i>Lubrification every 24 hours of work.....</i>	<i>79</i>
<i>Lubrification every 30 hours of work.....</i>	<i>80</i>
<i>Lubrification every 60 hours of work.....</i>	<i>80</i>
<i>Safety fuse</i>	<i>81</i>
<i>Oil change - Gearbox</i>	<i>82</i>
<i>DCF-CO (Cardan) reduction gearbox replacement.....</i>	<i>83 - 88</i>
<i>DCF-CO (Hydraulic Motor) reduction gearbox replacement.....</i>	<i>89 - 96</i>
<i>Crown and pinion replacement (Reduction gearbox).....</i>	<i>97 - 99</i>
<i>Operational Maintenance.....</i>	<i>100-101</i>
<i>Cares.....</i>	<i>102</i>
<i>General cleaning</i>	<i>102-103</i>
<i>Distributor preservation</i>	<i>103-104</i>
OPTIONAL.....	105
<i>Optional accessories.....</i>	<i>105-108</i>
IDENTIFICATION.....	109
<i>Identification plate.....</i>	<i>109</i>
<i>Product Identification</i>	<i>110</i>
NOTES.....	111
CERTIFICATE.....	112
<i>Certificate of warranty</i>	<i>112-118</i>

▪ **Baldan Warranty**

BALDAN IMPLEMENTOS AGRÍCOLAS S/A ensures the dealer normal performance of the implement for a period of six (6) months as of the delivery date on the retail invoice to the first final consumer.

During this period, **BALDAN** undertakes to repair defects in material and/or of manufacture of its liability, including labor, freight and other expenses of the dealer's liability.

In the warranty period, request and replacement of eventual defective parts shall be made to the dealer of the area, who will submit the faulty piece to **BALDAN** analysis.

When this procedure is not possible and the resolving capacity of the dealer is exhausted, the dealer will request the support of **BALDAN** Technical Assistance through a specific form distributed to dealers.

After analyzing the replaced items by **BALDAN** Technical Assistance, and concluding that it is not a warranty, then the dealer will be responsible for the costs related to the replacement; as well as material expenses, travel including accommodation and meals, accessories, lubricant used and other expenses arising from the call out to Technical Assistance, and **BALDAN** company is authorized to carry the respective invoice in the name of the resale.

Any repairment carried in the product within the dealer warranty deadline will only be authorized by **BALDAN** upon previous budget presentation describing parts and workforce to be executed.

The product is excluded from this term if it is repaired or modified by representatives not belonging to the **BALDAN** dealer network, as well as the application of non-genuine parts or components to the user's product.

This warranty is void where it is found that the defect or damage is caused by improper use of the product, failure to follow instructions or inexperience of the operator.

It is agreed that this warranty does not cover tires, polyethylene tanks, cardan, hydraulic components, etc., which are equipment guaranteed by their manufacturers.

Manufacturing and/or material defects, object of this warranty term, will not constitute, under any circumstances, grounds for termination of a purchase agreement, or for indemnification of any nature.

BALDAN reserves the right to change and/or perfect the technical characteristics of its products, without previous notice, and without obligation to proceed in the same way with the products previously manufactured.

▪ General Information

• To the owner

BALDAN IMPLEMENTOS AGRÍCOLAS S/A is not responsible for any damaged caused by accident due to usage, transportation, or in the improper or incorrect transportation of its implement, whether by negligence and/or inexperience of any person.

Only people with complete knowledge of the tractor and the implement should carry their transportation and operation.

BALDAN is not responsible for any damaged caused in unpredictable or unrelated situations to the normal use of the implement.

The incorrect handling of this equipment may result in severe or fatal accidents. Before running the equipment, carefully read the instructions contained in this manual. Make sure that the person responsible for the operation is instructed as the correct and safe handling. Also make sure that the operator has read and understood the instructions manual of the product.

ATTENTION

NR-31 - SAFETY AND HEALTH AT WORK IN AGRICULTURE, LIVESTOCK FARMING, FORESTRY, FOREST EXPLORATION AND AQUACULTURE.

This Regulatory Standard has the purpose of establishing precepts to be observed in the organization and work environment, compatible to the planning and development of agriculture, livestock, forestry, forest exploitation and aquaculture with safety and health and work environment.

MR. OWNER OR OPERATOR OF THE EQUIPMENT.
Read and carefully comply with provisions of NR-31.

For more information, refer to the site and read NR-31 in full.
<http://portal.mte.gov.br/legislacao/normas-regulamentadoras-1.htm>

▪ Safety rules

- To the operator



THIS SYMBOL INDICATES IMPORTANT SAFETY WARNING. IN THIS MANUAL, WHENEVER YOU FIND IT, READ THE FOLLOWING MESSAGE CAREFULLY AND PAY ATTENTION TO THE POSSIBILITY OF PERSONAL ACCIDENTS.

 **ATTENTION**

Carefully read the instructions manual to learn about the recommended safety practices.

 **ATTENTION**

Only start to operate the tractor when you are properly seated and with the seat belt locked.

 **ATTENTION**

Do not transport people on the tractor or over the equipment.

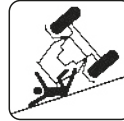
 **ATTENTION**

There are risks of severe injuries due to tipping when working in sloped terrains. Do not over speed.

 **ATTENTION**

Do not work with the tractor if the front has insufficient ballast to the rear equipment. Should there be a trend to lift, add weights or ballasts to the front or the front wheels.

 **ATTENTION**

Before performing any maintenance in your equipment, make sure it is properly stopped. Avoid being run over.

 **ATTENTION**

Careful when handling DCF-CO support since there is risk of accidents.

▪ Safety rules

ATTENTION

FOLLOW ALL RECOMMENDATIONS, WARNINGS AND SAFE PRACTICES RECOMMENDED IN THIS MANUAL, UNDERSTAND THE IMPORTANCE OF YOUR SAFETY. ACCIDENTS MAY LEAD TO DISABILITY OR INCLUDING DEATH. REMEMBER, ACCIDENTS CAN BE AVOIDED!

ATTENTION



Do not perform adjustments while DCF-CO is running. When performing any service on DCF-CO, switch off the tractor first. Use appropriate tools.

ATTENTION



Avoid heating parts near the fluid lines. Heating may generate fragility in the material, rupture and exit of the pressurized fluid, causing burns and injuries.

ATTENTION



When transporting the DCF-CO, do not exceed the speed of 25Km/h or 15 MPH in order to avoid risk of damage and accidents.

ATTENTION

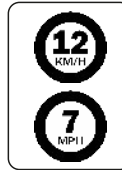

When working with the DCF-CO, do not exceed the speed of 12Km/h or 7 MPH, avoiding risk of damages and accidents.

ATTENTION

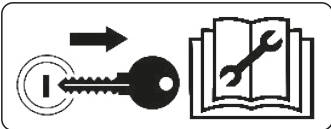

Remove the ignition key before performing any type of maintenance in DCF-CO. Protect yourself against possible injuries or death caused by DCF-CO unexpected start-up. Do not start up the tractor if DCF-CO is not properly coupled.

ATTENTION



Do not operate the DCF-CO if the transmission guard is not properly secured. Only remove the guard to replace the gear, replace it immediately. Do not perform adjustments while DCF-CO is in motion.

▪ Safety rules**! ATTENTION**

Do not climb or remain on the distributor discs under any circumstance. Ignoring this warning may cause severe accidents or death.

! ATTENTION

Do not climb or stand on the conveyor under any circumstance. Ignoring this warning may cause severe accidents or death.

! ATTENTION

Keep clear from mechanisms in motion (cardans, gears, conveyors, and especially distributor discs).

! ATTENTION

Always maintain places of access and work free of residues such as oil or grease to prevent accidents.

! ATTENTION

Hydraulic oil works under pressure and may cause serious injuries if there are any leakages.

Periodically check hoses for conservation. If there are any sign of leakage, replace them immediately. Before connecting or disconnecting hydraulic hoses, relief system pressure by activating the command with the tractor power switched off.

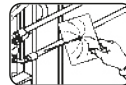
! ATTENTION

When searching for a possible leakage on the hoses, use a piece of cardboard or wood, never use your hands. Avoid fluid incision into the skin.

! ATTENTION

Before working on or transporting the DCF-CO, check for people or obstructions near the machine.

▪ Safety rules

ATTENTION



Never weld the wheel mounted with tire, the heat may cause air pressure increase and provoke the explosion of the tire.

When filling the tire, position yourself besides the tire, never in front of it. To inflate a tire, always use a containment device (inflation cage).

ATTENTION

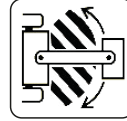

Keep the articulation area free while the DCF-CO is in operation.

In closed curves, prevent tractor wheels from touching the head.

ATTENTION



There is risk of injuries or death to the DCF-CO operator and bystanders during operations due to the following reasons:

- Body contact with rotating discs.
- Engagement of the body in the drive shaft and rotary shaft.

ATTENTION



Dispose residues inappropriately affects the environment and the ecology since you will be polluting rivers, canals or the soil.

Inform yourself about the proper way of recycling or disposing residues.

PROTECT THE ENVIRONMENT!

ATTENTION

Only stop the DCF-CO on a flat location. Do not park the DCF-CO uphill or downhill.

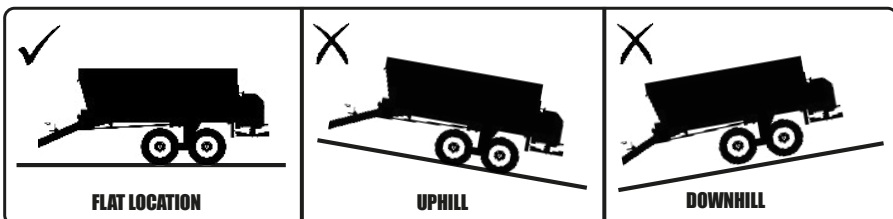

▪ Safety rules**⚠ ATTENTION**

To prevent intoxications, injuries or death when the DCF-CO is running and rotating discs are spinning, proceed as follows:

- Stop and turn the equipment off if there are people within 50 meters.
- Do not be exposed to product drift.

- Do not place hands or feet under the rotating discs.



- Never allow people on or under the DCF-CO.

⚠ ATTENTION

The DCF-CO may release fragments or throw objects at high speeds that can cause serious injury or death to bystanders.

⚠ ATTENTION

Be careful when driving or working with DCF-CO under power lines, low tree branches and other high obstructions, avoiding serious injury or even death.

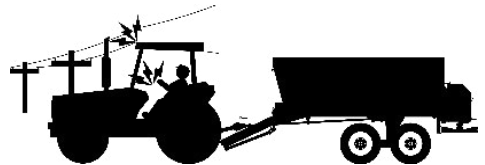
**⚠ ATTENTION**

Do not get exposed to the air coming out of rotating discs. Use protection.

- During handle and application, use PPE.
- Read the product's label carefully.
- Wash your hands thoroughly after handling the products.
- In case of intoxication by inhalation or aspiration, keep the person in a ventilated area and immediately seek medical advice, taking the label or the packaging of the product.

**INTOXICATION SYMPTOMS:**

Weakness, headache, chest pressure, chest tightness, blurred vision, unresponsive pupils, abundant salivation, sweating, nausea, vomiting and abdominal cramps.

▪ Safety rules

• PPE Equipment

ATTENTION

DO NOT WORK WITH DCF-CO WITHOUT FIRST WEARING PPES (SAFETY EQUIPMENT). IGNORING THIS WARNING MAY CAUSE DAMAGES TO HEALTH, SEVERE ACCIDENTS OR DEATH.

When performing certain procedures with the **DCF-CO**, place the following Safety Equipment (PPE) below:























IMPORTANT

The safety practice must be performed in all stages of working with the DCF-CO, thus avoiding accidents such as impact of objects, fall, noise, cuts and ergonomics, ie the person responsible for operating the DCF-CO is subject to internal and external damage to your body.













 **OBSERVATION** | All PPEs (Safety Equipment) should have certificate of authenticity.



▪ Warnings

-  When operating with the DCF-CO, do not let people stand near to or on the machine.
-  When operating the DCF-CO, check that there are no people in the line of launch of the distributor discs.
-  When performing any maintenance service, use PPEs equipment.
-  When conducting checks inside the DCF-CO, do not lean on the distributor discs.
-  Do not wear loose clothing, as it may get caught in the DCF-CO.
-  When operating the tractor engine, properly sit in the operator's seat and be aware of the full knowledge of the correct and safe handling of both the tractor and the DCF-CO. Always put the gear shift in neutral position, unplug the power take-off gear switch and place the hydraulic controls in neutral position.
-  Do not start the engine in a closed environment or with no proper ventilation since the exhaust gases are harmful to health.
-  When maneuvering the tractor to engage the DCF-CO, make sure you have enough space and no one around, always maneuver at idle and be prepared to brake in an emergency.
-  Do not perform adjustments while the DCF-CO is in operation.
-  When working in sloped terrains, proceed with precautions, always trying to maintain the required stability. In case of imbalance, reduce acceleration, turn the wheels to the slope side of the terrain and never lift the DCF-CO.
-  Always drive the tractor at speeds compatible to safety, especially during works in bumpy terrains or slopes, keep the tractor always engaged.
-  When driving the tractor in highways, keep the brake pedals interconnected.
-  Do not work with the tractor in highways, keep the brake pedals interconnected.
-  When leaving the tractor, put the gear lever in neutral position and apply the parking brake. Never leave the DCF-CO engaged in the tractor when its hydraulic system is in the raised position.
-  All maintenance work in the DCF-CO must be carried out only after stopping and turning the tractor off.
-  Do not travel on highways especially at night. Use warnings signs throughout the route.
-  If you need to travel on highways with the DCF-CO, consult the transit authorities.
-  Do not allow people who have not been trained to use the DCF-CO, that is, that do not know how to operate it correctly.
-  Do not transport or work with the DCF-CO near obstacles, rivers or streams.
-  The transportation of people on self-propelled machines and implements is forbidden.
-  Changes in the original features of the DCF-CO are not allowed, as they may chance safety, operation, and useful life characteristics of the DCF-CO.

▪ Warnings

-  Please read all safety information contained in this manual and the DCF-CO carefully.
-  Always check that the DCF-CO is in perfect conditions of use. In the event of any irregularity the may interfere with the operation of the DCF-CO, ensure proper maintenance before any work or transportation.
-  Maintenance and especially inspection in risk areas of the DCF-CO must be done by qualified or trained workers only, observing all safety guidelines. Before starting maintance, disconnect all DCF-CO drive systems.
-  Periodically check all components of the DCF-CO before use.
-  Due to the equipment used and work conditions on field or in maintenance areas, precautions are required. Baldan has no direct control over precautions, so it is the owner's responsibility to implement safety procedures while working with the DCF-CO.
-  Check the recommended minimum tractor power for each DCF-CO model. Only use the tractor wit power and ballast compatible with the load and topography of the terrain.
-  When transporting the DCF-CO, travel at speeds compatible with the terrain and never exceed 16 km/h, as this reduces maintenance and consequently increases the useful life of the DCF-CO.
-  Do not approach the moving distributors discs.
-  Do not stay in the product throwing line.
-  Never uncouple the DCF-CO with product in the trolley. Ignoring this warning can cause risk of tipping over accidents.
-  Alcoholic beverage or some medications may cause loss of reflexes and change the operator's physical conditions. Therefore, never operate the DCF-CO under the influence of these substance.
-  Read or explain all the procedures of this manual to the operator who cannot read.

In the case of doubts consult the After Sales.
Phone: 0800-152577 / E-mail: posvenda@baldan.com.br

▪ Components**• DCF-CO - Lime, Fertilizer and Organic Fertilizer Spreader (Cardan)**

- | | |
|-------------------------------|------------------------------------|
| 1. Bucket | 10. Tire |
| 2. Modulated Conveyor | 11. Transmission protection |
| 3. Central Shaft | 12. Distributor discs |
| 4. Central Cardan | 13. Adjustable vanes |
| 5. Lateral Cardan | 14. Gearbox |
| 6. Hook Shackle | 15. Lever |
| 7. Support Bracket | 16. Rear Cover |
| 8. Conveyor Turnbuckle | 17. Deflector |
| 9. Framework | |

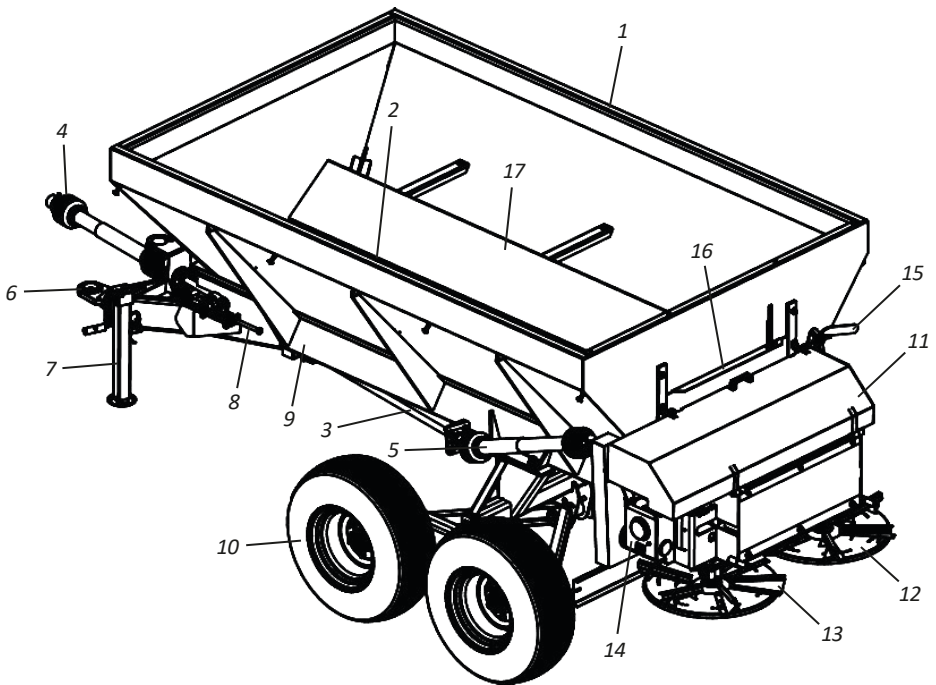

▪ Components

• DCF-CO - Lime, Fertilizer and Organic Fertilizer Spreader (Hydraulic Engine)

- | | |
|------------------------|-----------------------------|
| 1. Bucket | 9. Hydraulic Hose |
| 2. Modulated Conveyor | 10. Hydraulic engine |
| 3. Deflector | 11. Transmission Protection |
| 4. Hook Shackle | 12. Distributor Discs |
| 5. Support Bracket | 13. Adjustable Vanes |
| 6. Conveyor Turnbuckle | 14. Gearbox |
| 7. Framework | 15. Lever |
| 8. Tire | 16. Rear Cover |

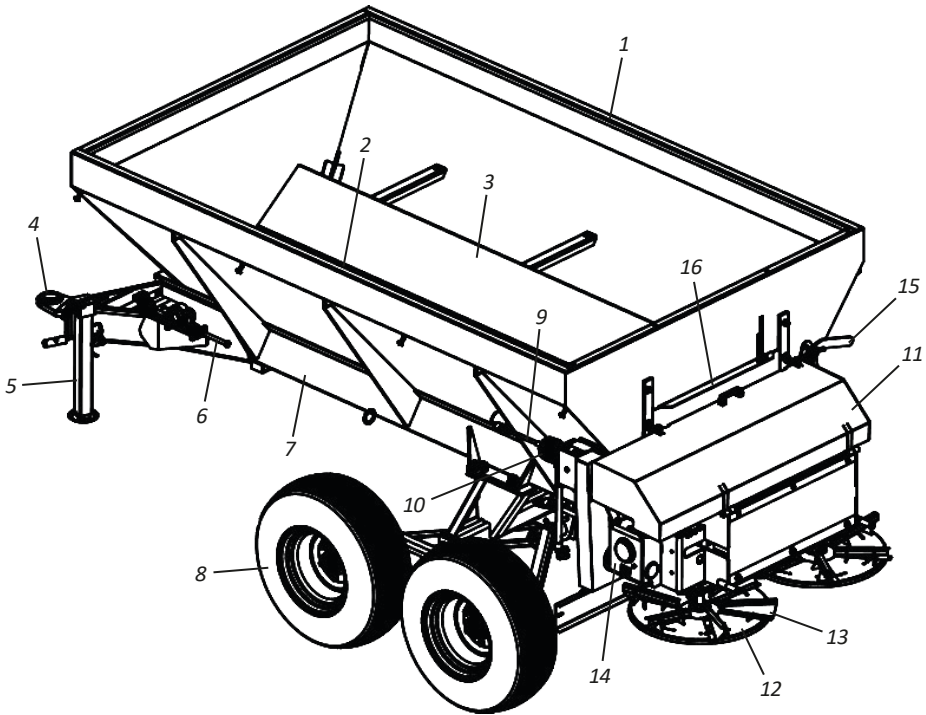

▪ Dimensions

- DCF-CO - Lime, Fertilizer and Organic Fertilizer Spreader

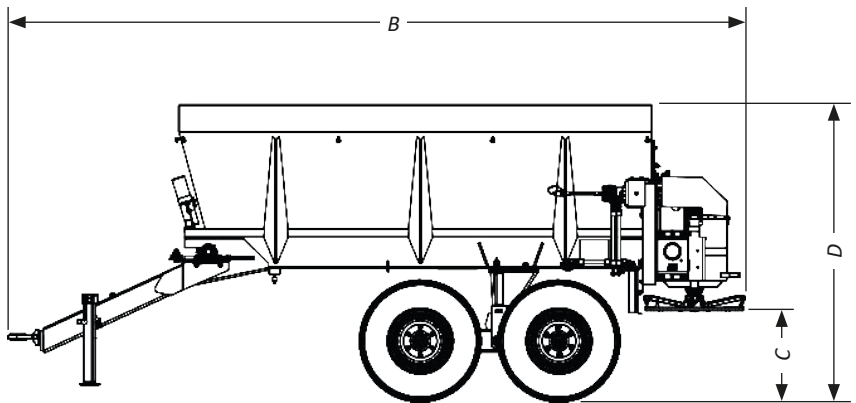
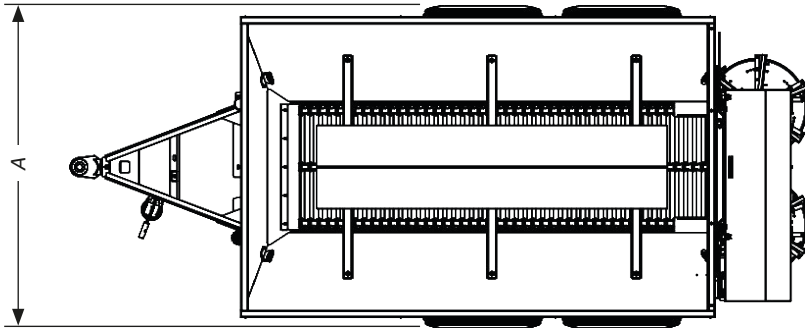

Model	Measurement A (mm)	Measurement B (mm)	Measurement C (mm)	Measurement D (mm)
DCF-CO 3000 (Cardan and Hydraulic Engine)	1800	3900	582	1700
DCF-CO 6000 (Cardan and Hydraulic Engine)	2000	4600	582	1800
DCF-CO 8000 (Cardan and Hydraulic Engine)	2000	4610	582	1900

▪ Specifications

- DCF-CO - Lime, Fertilizer and Organic Fertilizer Spreader (Cardan)
- DCF-CO - Lime, Fertilizer and Organic Fertilizer Spreader (Hydraulic Engine)

Model	Load Capacity (m ³)	Wheelset	Standard Tires	Approximate Weight (Kg)	Tractor Power (Hp)
DCF-CO 3000	1,60	Simple (2 Tires)	750x16 (2 Tires)	1070	50 - 70
DCF-CO 6000	2,80	Tandem (4 Tires)	750x16 (4 Tires)	1390	75 - 90
DCF-CO 8000	3,80	Tandem (4 Tires)	11L-15 (4 Tires)	1480	90 - 100

Approximate gauge 1600 mm
 PTO in RPM 540 Rpm

Baldan reserves the right to change and/or perfect the technical characteristics of its products, without previous notice, and without obligation to proceed in the same way with the products previously manufactured. Technical specifications are approximate and informed under normal work conditions.

INTENDED USING OF THE DCF-CO

- The **DCF-CO** is a high strength equipment, whose special feature is greater load capacity and a thicker belt allowing better distribution of the organic compound.
- The **DCF-CO** must be driven and operated by a properly instructed operator.

DCF-CO USE IS NOT ALLOWED

- To avoid damage, serious accidents or death, DO NOT transport people on any part of the **DCF-CO**.
- Using the **DCF-CO** to attach, tow, or push other implements or attachments is NOT allowed.
- The **DCF-CO** should NOT be used by an experienced operator who does not know all the driving, command and operation techniques.

▪ Assembly

The **DCF-CO** leaves factory semi-assembled, only requiring the assembly of its tires, which were removed for easier loading and transportatin. To assembly it, follow the instructions bellow.

⚠ The **DCF-CO** must be assembled in the resale, by people trained, instructed and qualified for this work.

⚠ Before assembling the **DCF-CO**, look for a good place for easy identification of the parts and their assembly.

⚠ Do not wear loose clothing, as they may get caught in the **DCF-CO**.

• Tire Assembly

In order to assemble the tires, proceed as follows:

01 - Attach the tire (1) to the hub (2) securing it with screws (3) and nuts (4).

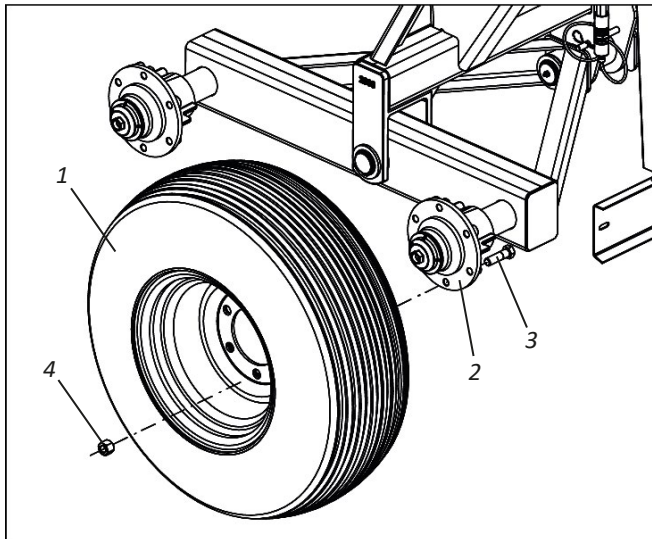

⚠ ATTENTION

Check the correct tire calibration on page 73.

📌 NOTE

Repeat the procedure above to assemble the other discs.

▪ Assembly

• Assembly the driver box (Optional) - Part I

To mount the driver box (1) proceed as follows:

- 01** - Loosen the screws (1), flat washers (2), pressure washers (3), and nuts (4).
- 02** - Then, attach the driver box (5) to the **DCF-CO** and use the same screws (1), plain washers (2), pressure washers (3) and nuts (4) for the central fixing of the driver box.
- 03** - The, secure the driver box (6), securing them through screws (7), plain washers (8), pressure washers (9), and nuts (10).

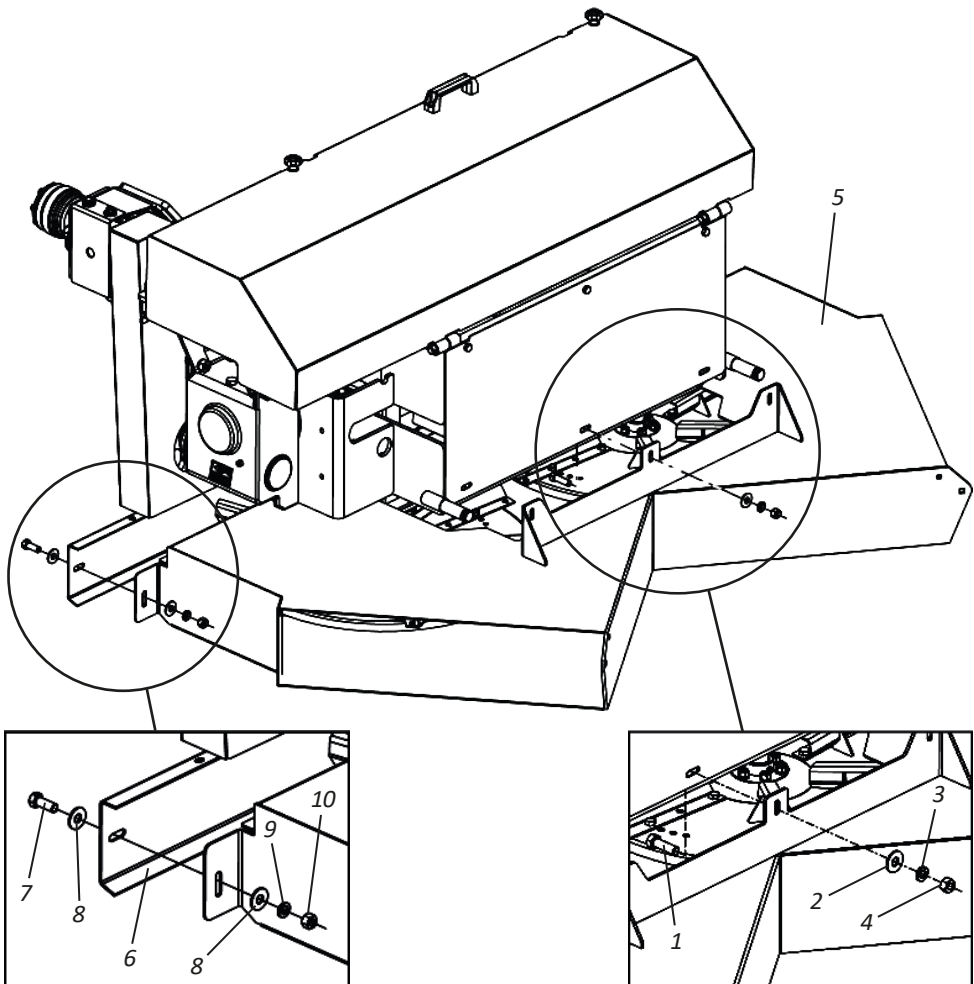

▪ Assembly**• Assembly the driver box (Optional) - Part II**

- 04-** Then fasten the guide plates (11) to the guide plates (5) through the screws (12), plain washers (13), lock washers (14) and nuts (15).
- 05-** Finish by replacing the pin (16), flat washer (17), and wing nut (18).

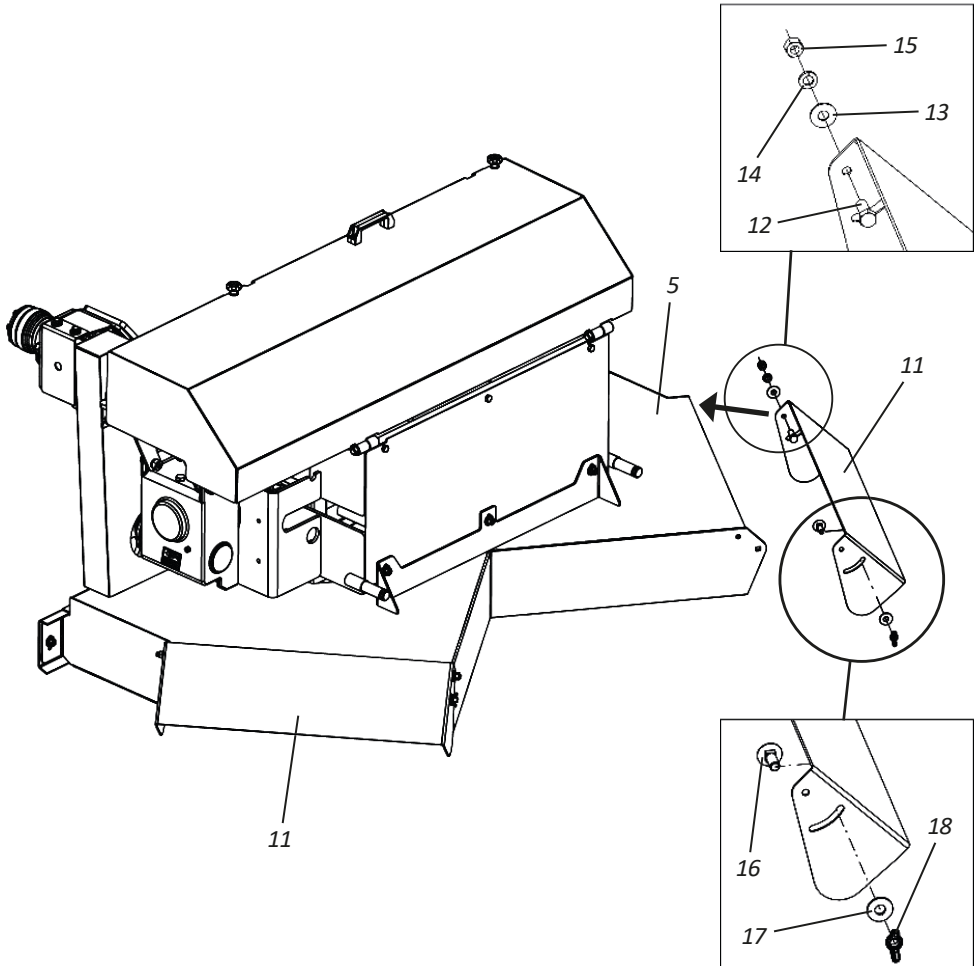
**ATTENTION**

To adjust the guide plates (11), follow the instructions on page 59.

▪ Assembly

• Assembling the canvas baffle (Optional) - Part I

Deflector assemble the canvas baffle, proceed as follows:

- 01** - Couple the central frame of the deflector (1) to the **DCF-CO** attaching it with flat washers (2) and locks (3).

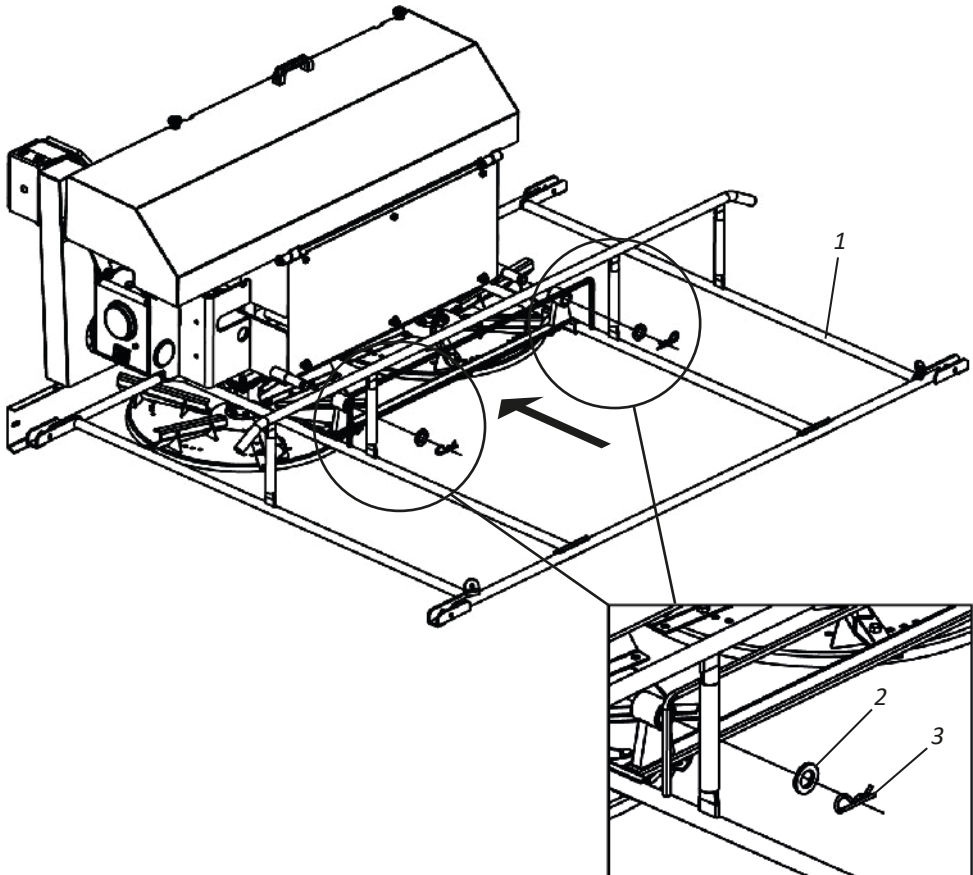

▪ Assembly

• Assembling the canvas baffle (Optional) - Part II

02 - Then, attach the left side frame (4) to the central frame of the baffle (1), securing with pins (5), plain washers (6) and cotter pins (7).

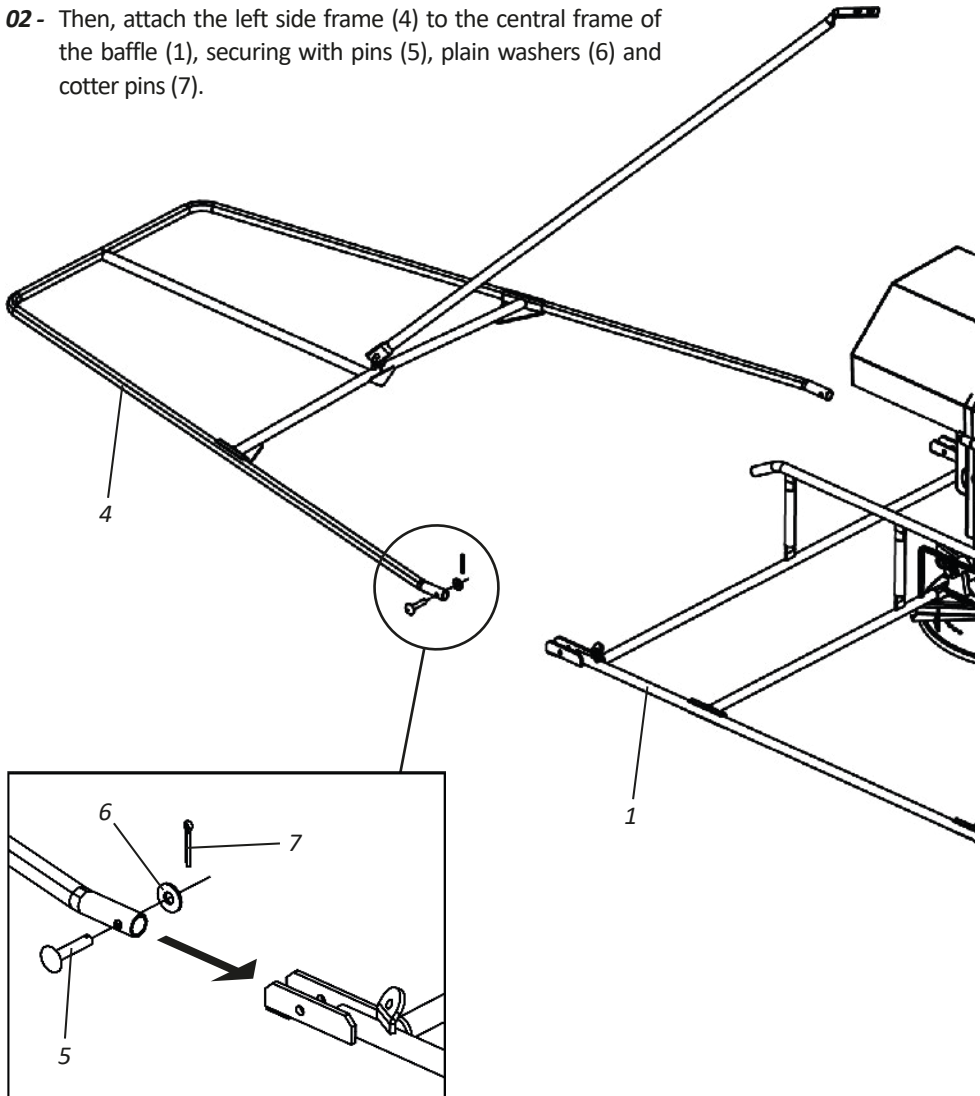

Repeat the procedure above to assembly the right side frame on the central frame of the baffle (1).

▪ Assembly

• Assembling the canvas baffle (Optional) - Part III

03 - Then, place the canvas (8) over the frames (9), passing the rods (10) inside holes "A".

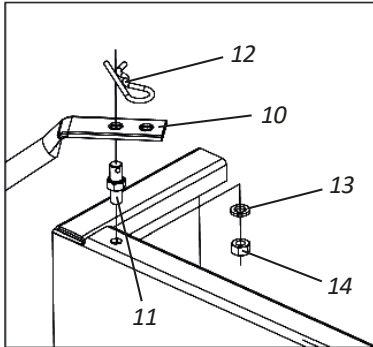

04 - Then, fasten the rods (10) in the **DCF-CO**, using the shaft (11), lock (12), pressure washers (13) and nut (14).

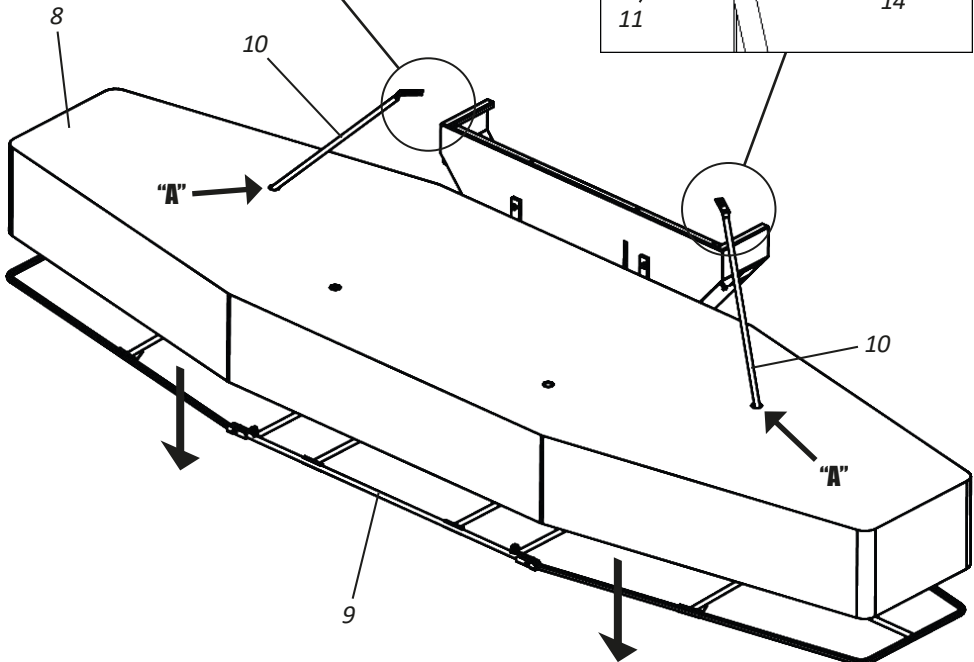
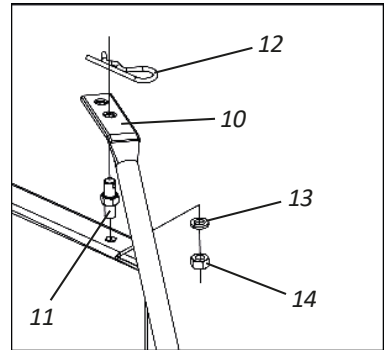

▪ Assembly**• Assembling the canvas baffle (Optional) - Part IV**

05 - Then, slide the rods (15) through holes "B" and secure them to the frames (9) through the screws (16), pressure washers (17) and nuts (18).

06 - Then, fasten the rods (15) in the **DCF-CO**, using the shaft (16), lock (17), pressure washers (18) and nuts (19).

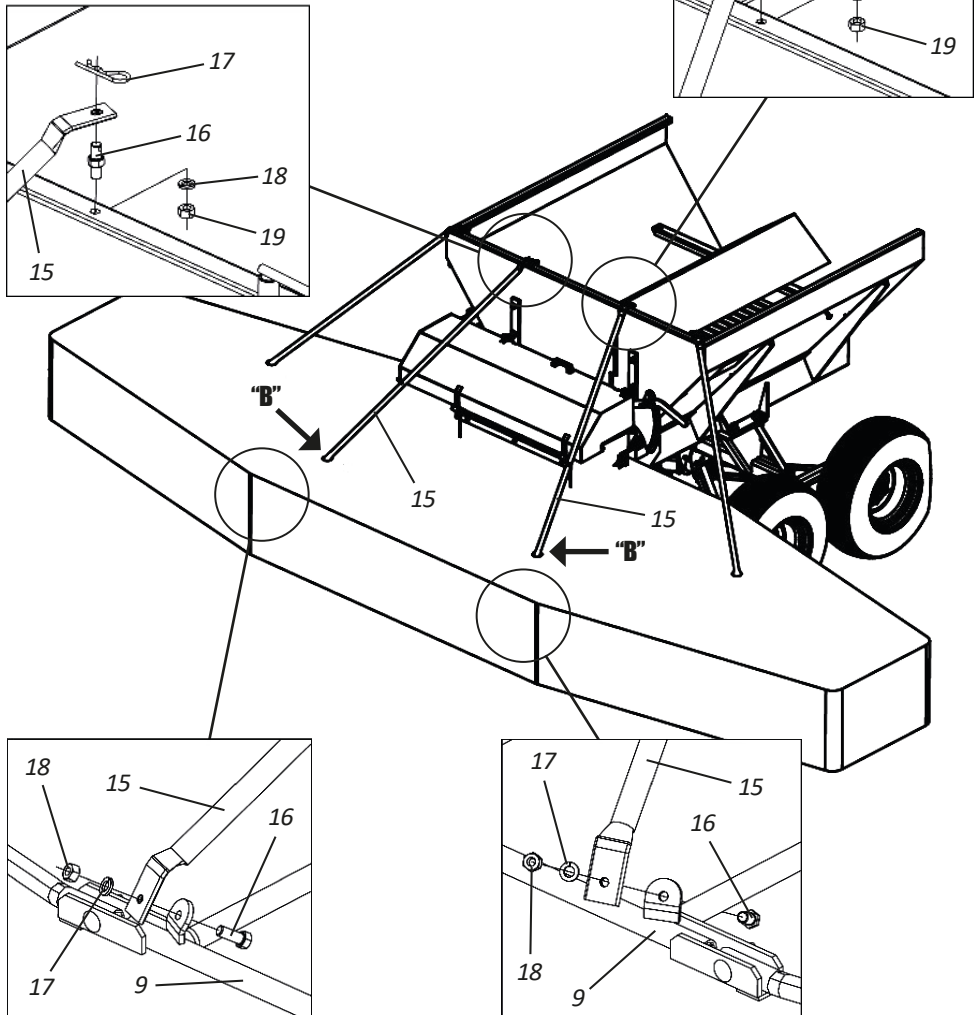

▪ Assembly

• Assembling the canvas baffle (Optional) - Part V

07- Finish by placing the spacers (20) on the bar inside the canvas (8).

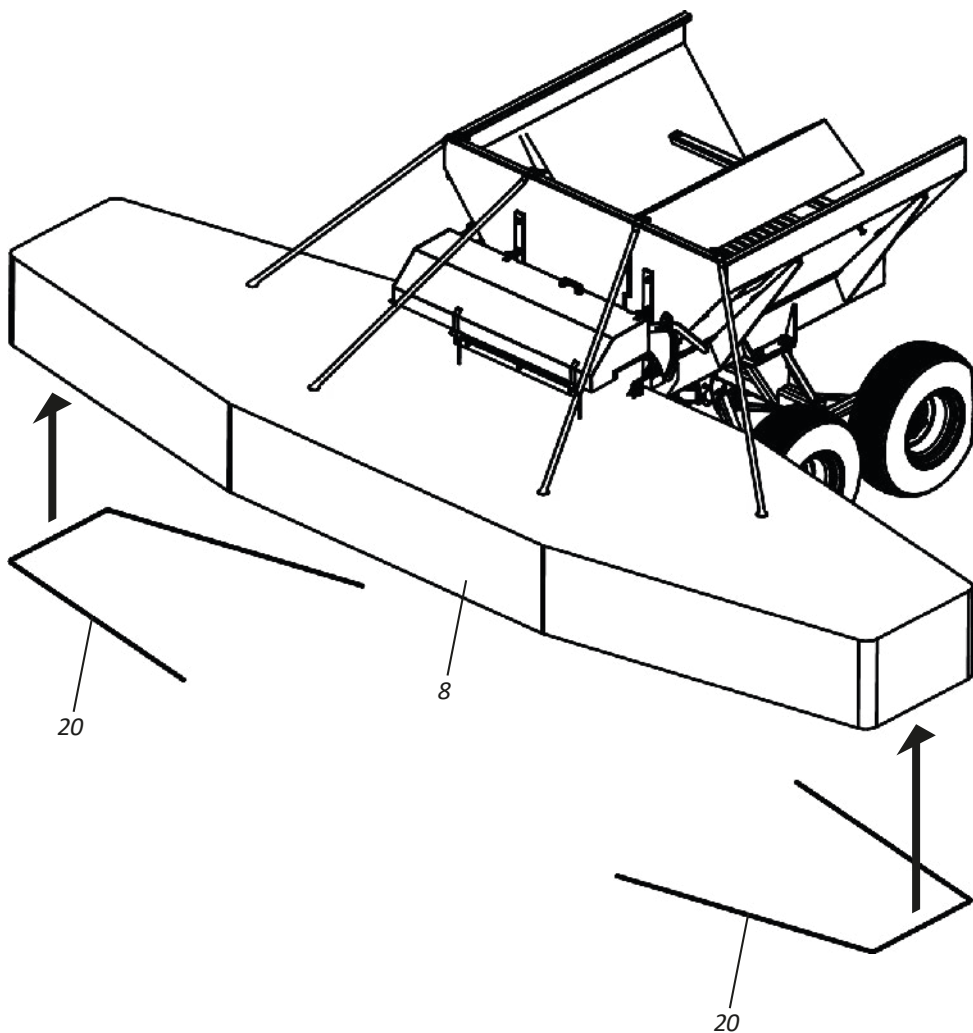

▪ Assembly

- Assembling the rubber baffle (Optional) - Part I

⚠ ATTENTION

Before beginning the rubber baffle assembly procedure (optional), make sure that the DCF-CO is engaged to the tractor. Ignoring this warning will make the DCF-CO tip, causing damage to the equipment, serious injury or death.

To assemble the rubber baffle, proceed as follows:

- 01** - Remove screws (1), flat washers (2), pressure washers (3) and nuts (4).

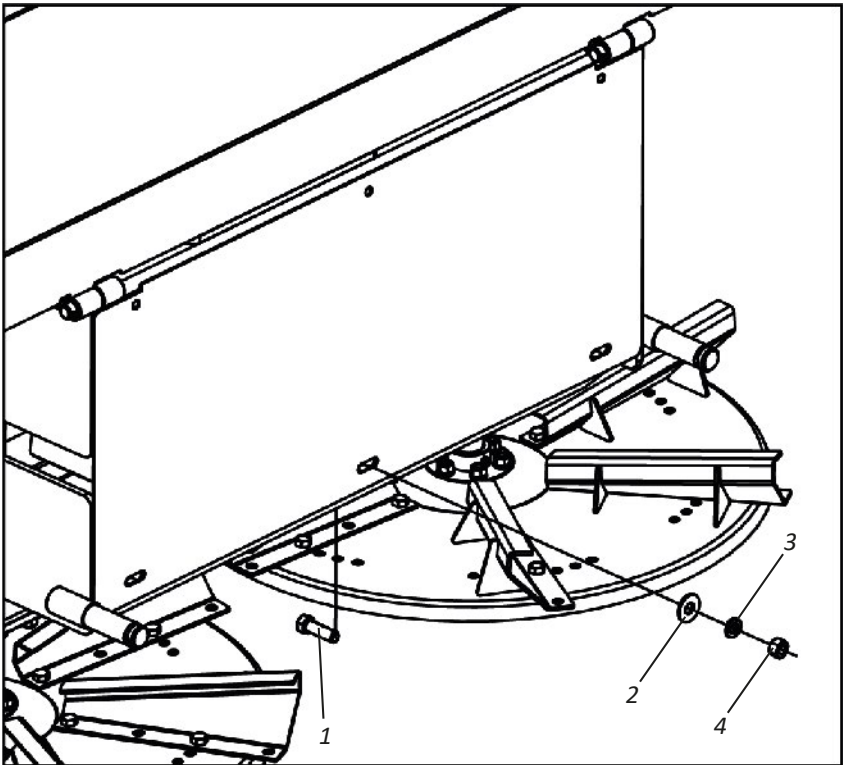
**NOTE**

Removed screws (1), plain washers (2), spring washers (3) and nuts (4) will be replaced by screws, washers and nuts accompanying the baffle.

▪ Assembly

• Assembling the rubber baffle (Optional) - Part II

02 - Then, couple the central guard of the baffle (5) into the **DCF-CO** attaching it with screws (6), flat washers (7), pressure washers (8) and nuts (9).

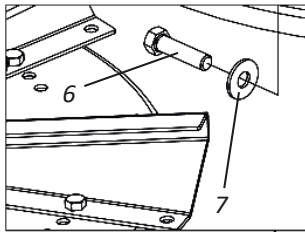

03 - Then fasten the central frame of the baffle (5) on the rear support (10) through the bolts (11), plain washers (12), lock washers (13) and nuts (14).

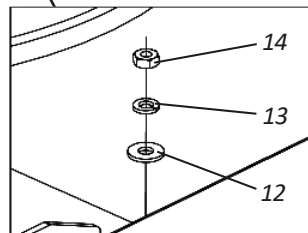
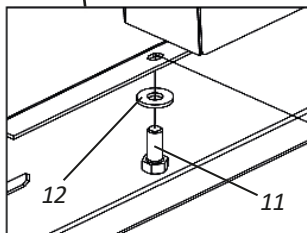
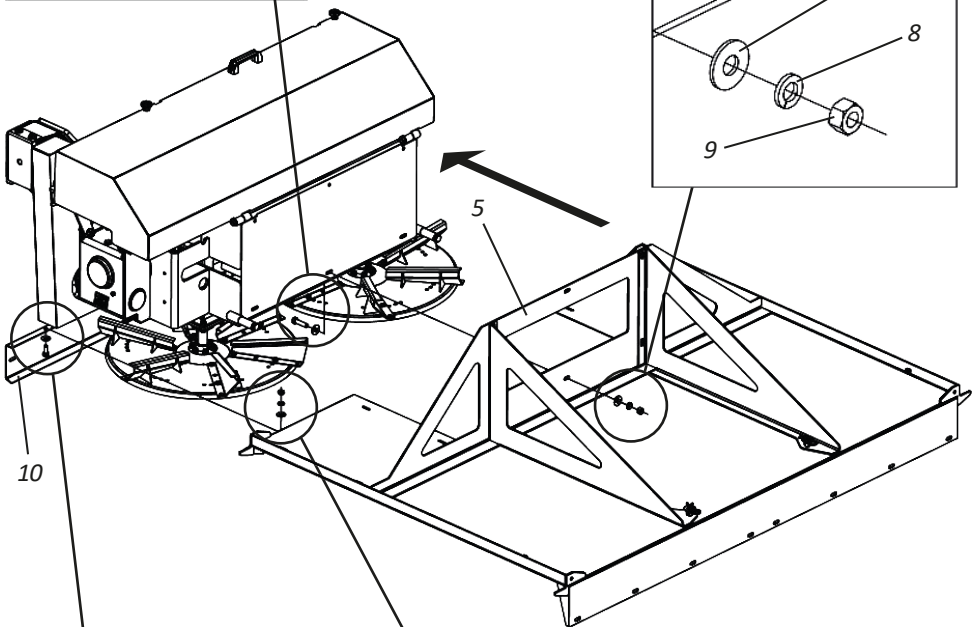
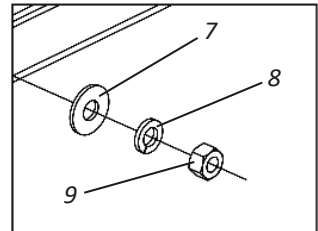

▪ Assembly

• Assembling the rubber baffle (Optional) - Part III

04 - Then attach the sealing plate (15) in the central frame of the baffle (5) using screws (16), flat washers (17), pressure washers (18) and nuts (19).

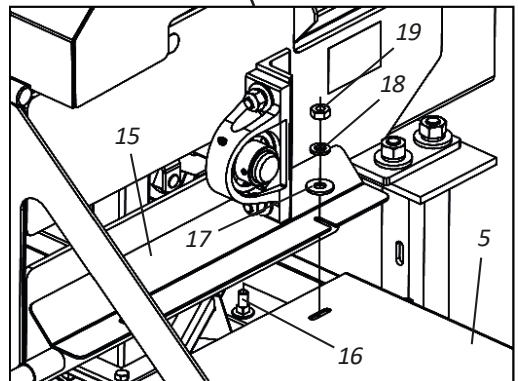
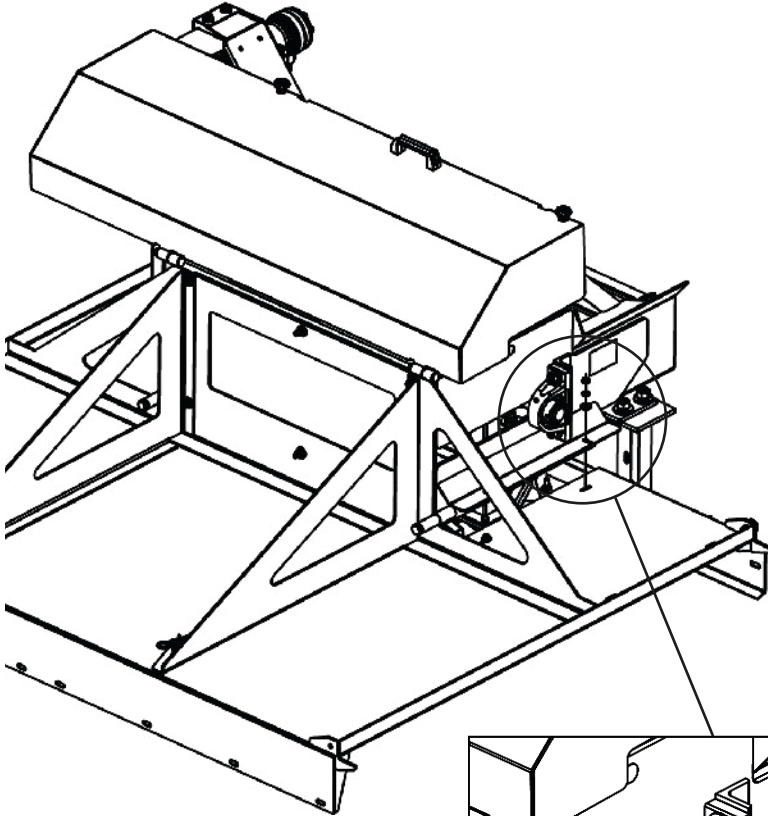

NOTE

The cover plate (15) must be mounted on both sides of the DCF-CO.

▪ Assembly

• Assembling the rubber baffle (Optional) - Part IV

05 - The secure the rear guard (20) in the central frame of the baffle (5) using support bars (21), bearing (22), screws (23), plain washers (24), pressure washers (25) and nuts (26). Finish the assembly by attaching the support bracket (27).

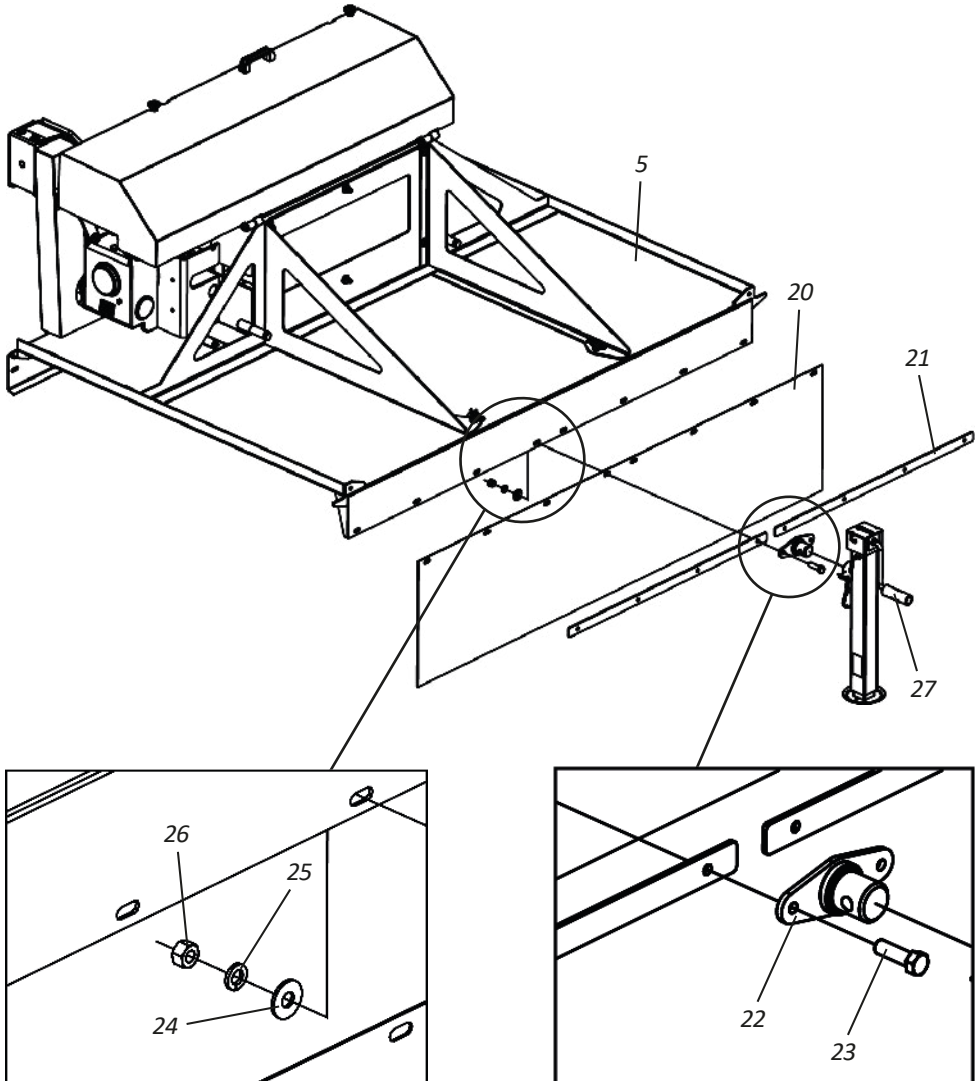

▪ Assembly

• Assembling the rubber baffle (Optional) - Part V

06- Then couple the left side frame (28) in the central frame of the baffle (5) securing it with screws (29), bushing (30), pressure washers (31) and nuts (32).

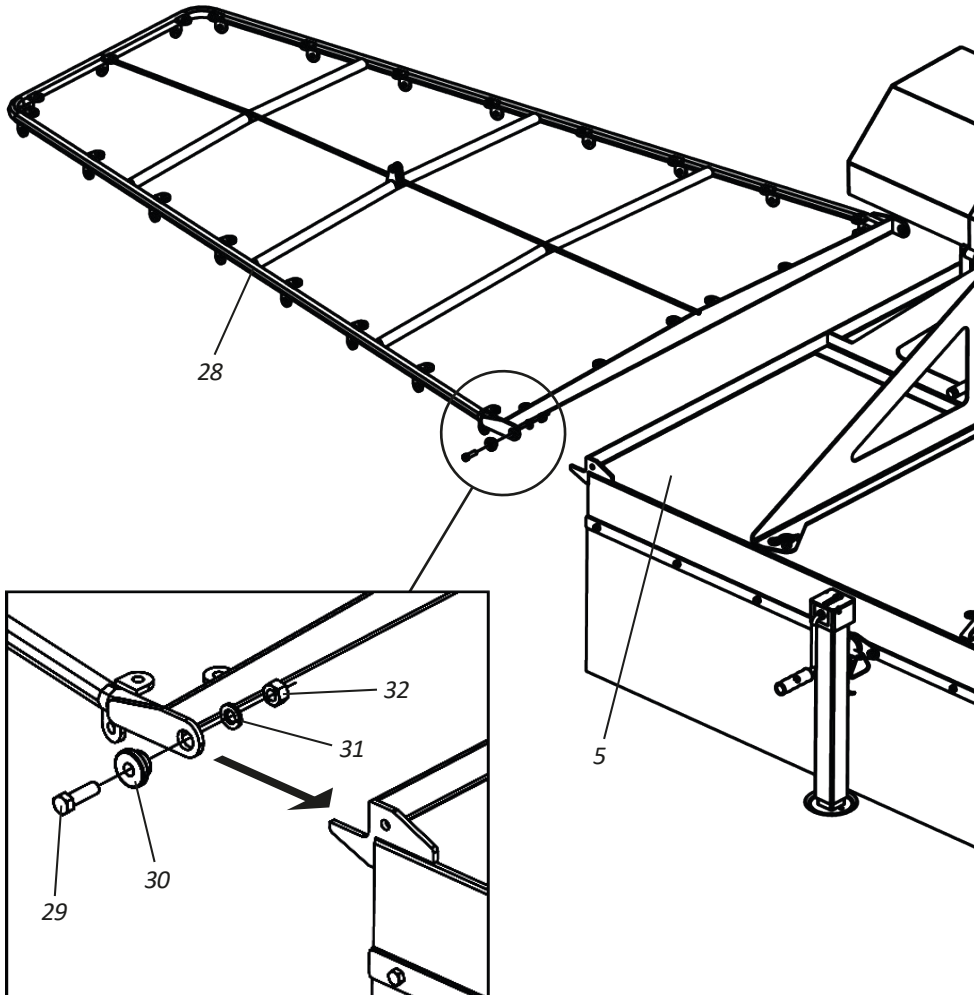

Repeat the procedure above to assembly the right side frame on the central frame of the baffle (5).

▪ Montagem

• Montagem do defletor de borracha (Opcional) - Parte VI

07 - The attach the side rubber guard (33) on the left side frame (28) using bars (34), screws (35), lock washers (36), and nuts (37).

08 - The place the upper rubber guard (38) on the left side frame (28), securing it through the bars (39), screws (40), pressure washers (41) and nuts (42).

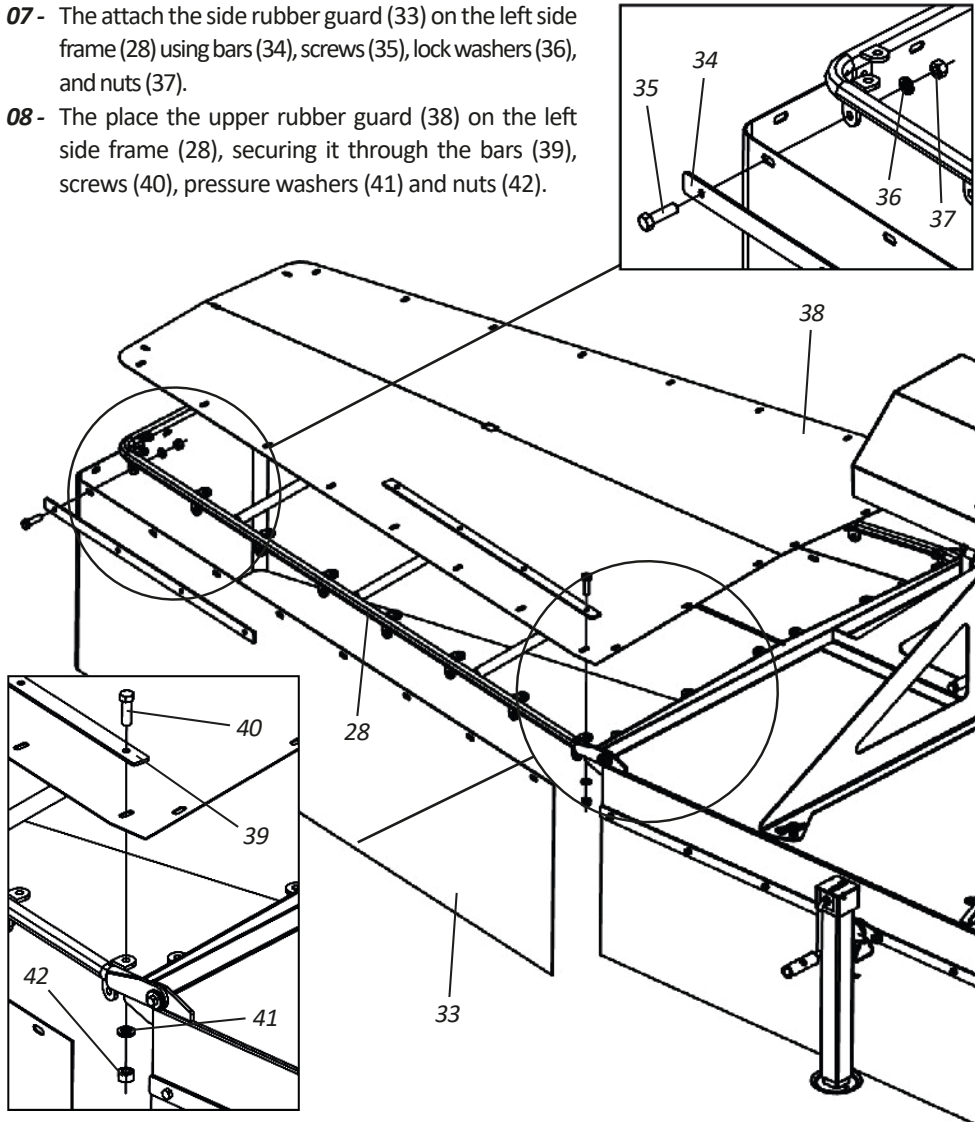

NOTE | Repeat the procedure above to assemble the side and upper rubber guards on the right side frame.

▪ Assembly**• Assembling the rubber baffle (Optional) - Part VII**

09- Finish by fastening the adjuster (43) on the left side frame (28), through the pin (44) and lock (45) and on the **DCF-CO**, using the shaft (46), a flat washer (47), a lock (48), washer (49) and nut (50).

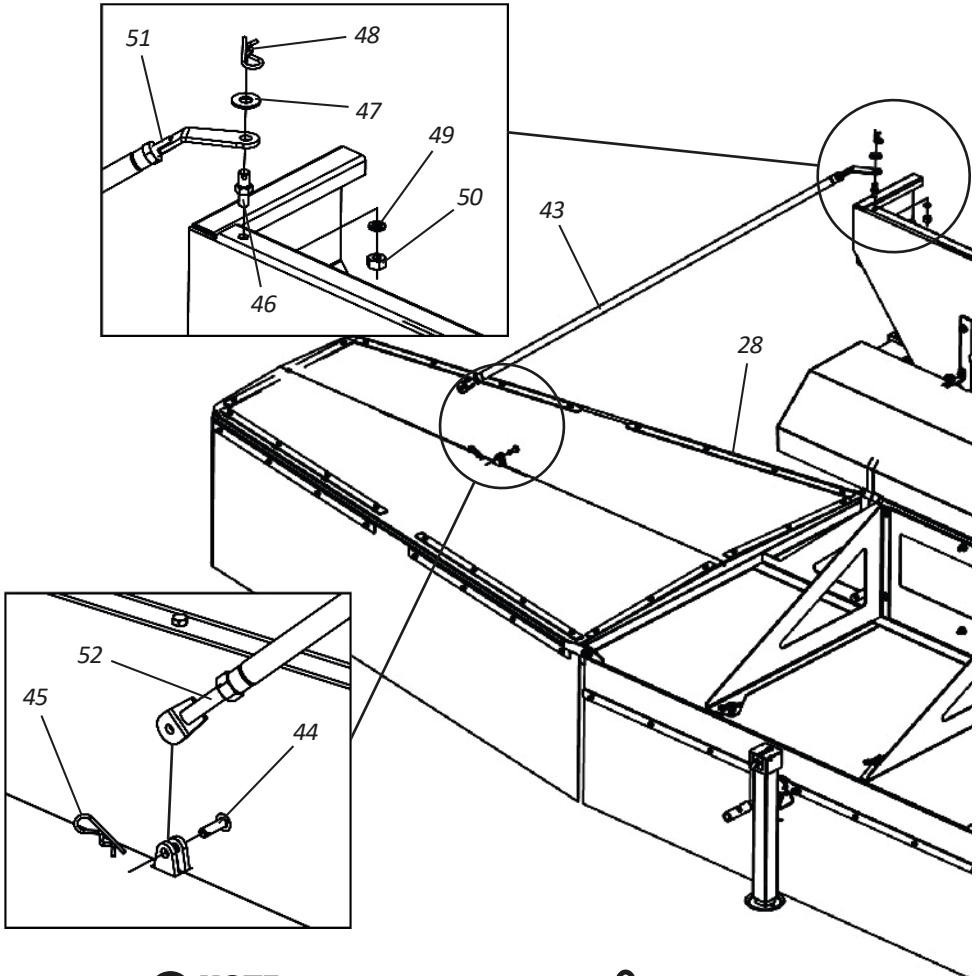
**NOTE**

Repeat the procedure above to assemble the adjuster on left side frame.

ATTENTION

When fixing the adjuster (43) on the side frame, its length must be adjusted through the rods (51 and 52).

■ Assembly

• Assembling the hydraulic system - DCF-CO 3000 (Hydraulic Engine)

When purchased with a hydraulic engine, the **DCF-CO 3000** comes with **PACKAGING** containing:

- 1 1/4" x 5700 mm hose w/ 1 TRG and 1 TRF and 1 w/ male quick coupling
- 1 nipple of R.7/16" 20 FPP-UNF X M12 X 1.5 x 35 mm hexagonal of 5/8".

When engaging the **DCF-CO with hydraulic engine**, check that the tractor has a slot for a drain, if equipped, remove the cover (1) from the hydraulic engine (2) and attach the nipple (3) and the hydraulic hose (4) of the **PACKAGING**.

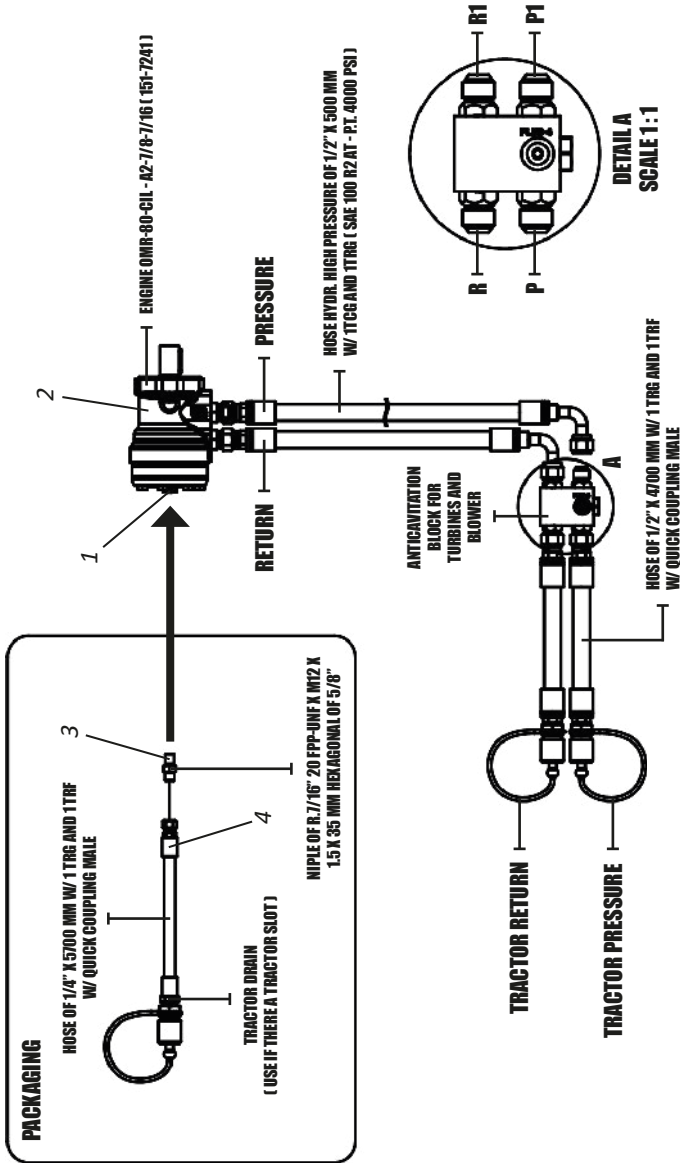

IMPORTANT | if the tractor has no drain slot, nipple (3) and hydraulic hose (4) will not be used.

▪ **Assembly**

- Assembling the hydraulic system - DCF-CO 6000/8000 (Hydraulic Engine)

When purchased with a hydraulic engine, the **DCF-CO 6000/8000** comes with a **PACKAGING**, containing:

- 1 1/4" x 6400 mm w/ 1 TRG and 1 TRF and 1 w/ male quick coupling.
- 1 nipple of R.7/16" 20 FPP-UNF X M12 X 1.5 x 35 mm hexagonal of 5/8".

When engaging the **DCF-CO with hydraulic engine**, check that the tractor has a slot for a drain, if equipped, remove the cover (1) from the hydraulic engine (2) and attach the nipple (3) and hydraulic hose (4) of the **PACKAGING**.

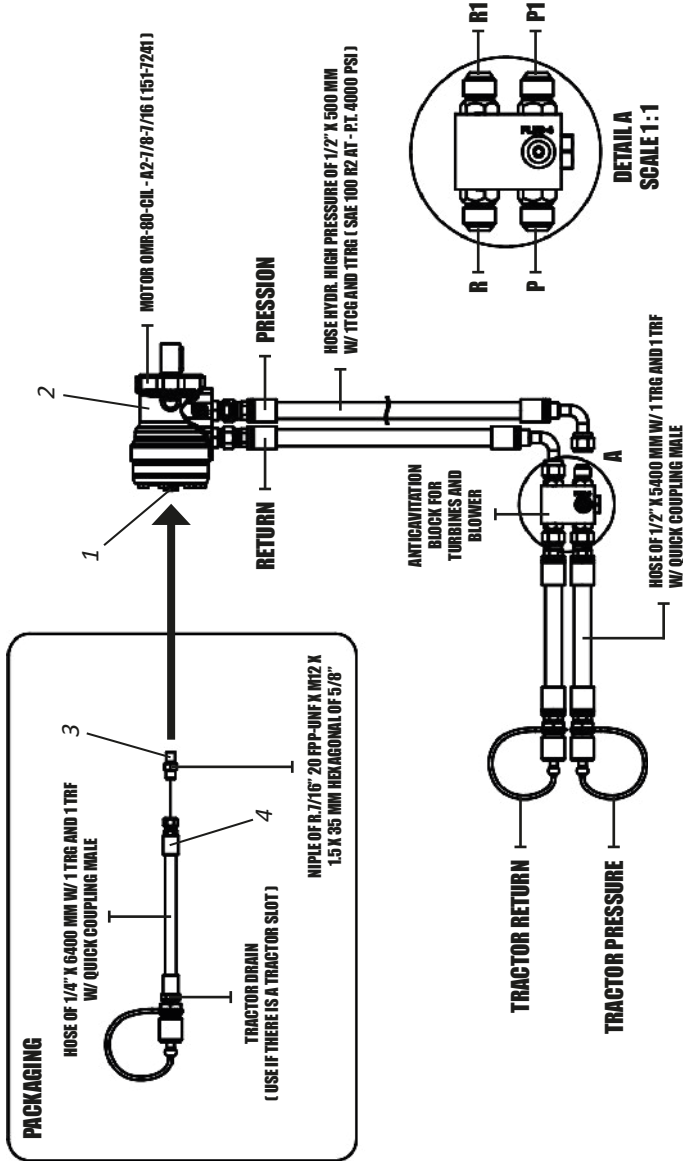

! IMPORTANT | If the tractor has no drain slot, nipple (3) and hydraulic hose (4) will not be used.

▪ Unlock

• Unlocking the wheelset pin

For hoisting purposes, the **DCF-CO 6000** and **8000** are ex-factory with a locked wheel holder (1). When completing the tire assembly, unlock the wheel support (1) before work or transport and proceed as follows:

01 - Loosen the pin (2) and remove the pin (3).

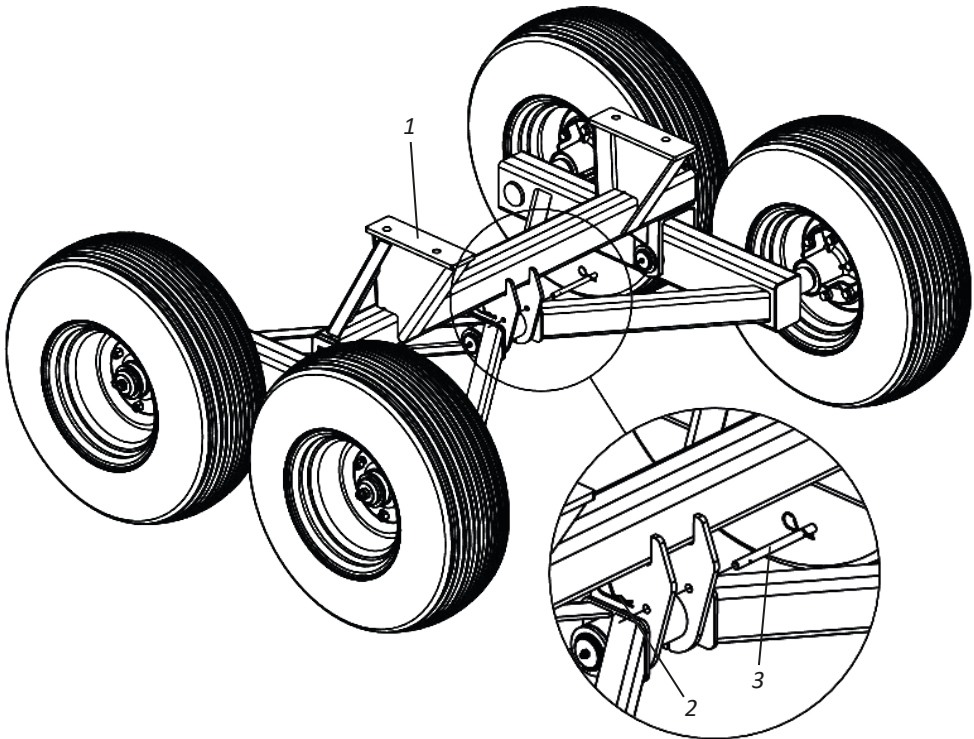

ATTENTION

Do not work or transport the DCF-CO 6000 and 8000 without removing the pin (3).

NOTE

The only function of the pin (3) is to level the wheel holder (1) when the dispenser is hoisted for loading.

▪ Hitch

• Tractor hitch - DCF-CO (Cardan)

Before hitching the **DCF-CO** to the tractor, make sure the tractor is ready for work by observing the following item:

- Check if the tractor has weight or ballast sets in the front wheels to grant the tractor greater stability and traction on the ground.

To couple the **DCF-CO**, proceed as follows:

- 01** - Level the coupling head (1) of the **DCF-CO** with the tractor's coupling through the adjuster (2).
- 02** - Then, slowly approach the tractor to the **DCF-CO** in reverse, paying attention when to use the brakes.
- 03** - Then couple the **DCF-CO** header (1) to the tractor by attaching it through the hitch pin (3), flat washer (4) and lock (5).

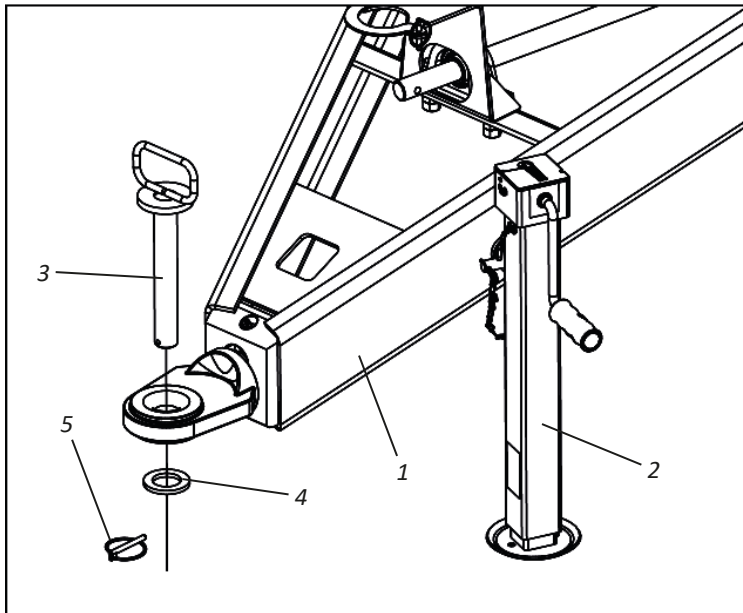

! IMPORTANT

When coupling the DCF-CO, look for a safe and accessible location. Always use low gear with low acceleration.

▪ Hitch

• Tractor hitch - DCF-CO (Hydraulic Engine)

Before hitching the **DCF-CO** to the tractor, make sure the tractor is ready for work by observing the following item:

- Check if the tractor has weight or ballast sets in the front wheels to grant the tractor greater stability and traction on the ground.

To couple the **DCF-CO**, proceed as follows:

- 01** - Level the coupling head (1) of the **DCF-CO** with the tractor's coupling through the adjuster (2).
- 02** - Then, slowly approach the tractor to the **DCF-CO** in reverse, paying attention when to use the brakes.
- 03** - Then, couple the **DCF-CO** header (1) to the tractor by attaching it through the hitch pin (3), flat washer (4) and lock (5).
- 04** - Then attach the hydraulic hoses (6) to the tractor.

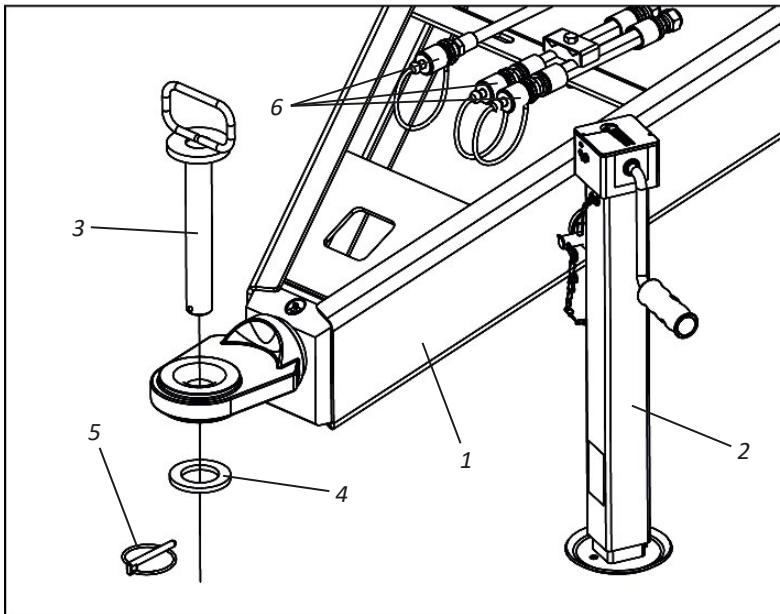

! IMPORTANT

When coupling the DCF-CO, look for a safe and accessible location. Always use low gear with low acceleration.

▪ Hitch**• Support bracket**

After engaging the **DCF-CO** on the tractor, place the support bracket (1) in the transportation/work position by proceeding as follows:

01 - Remove the support bracket (1) from point "A" and place it on "B".

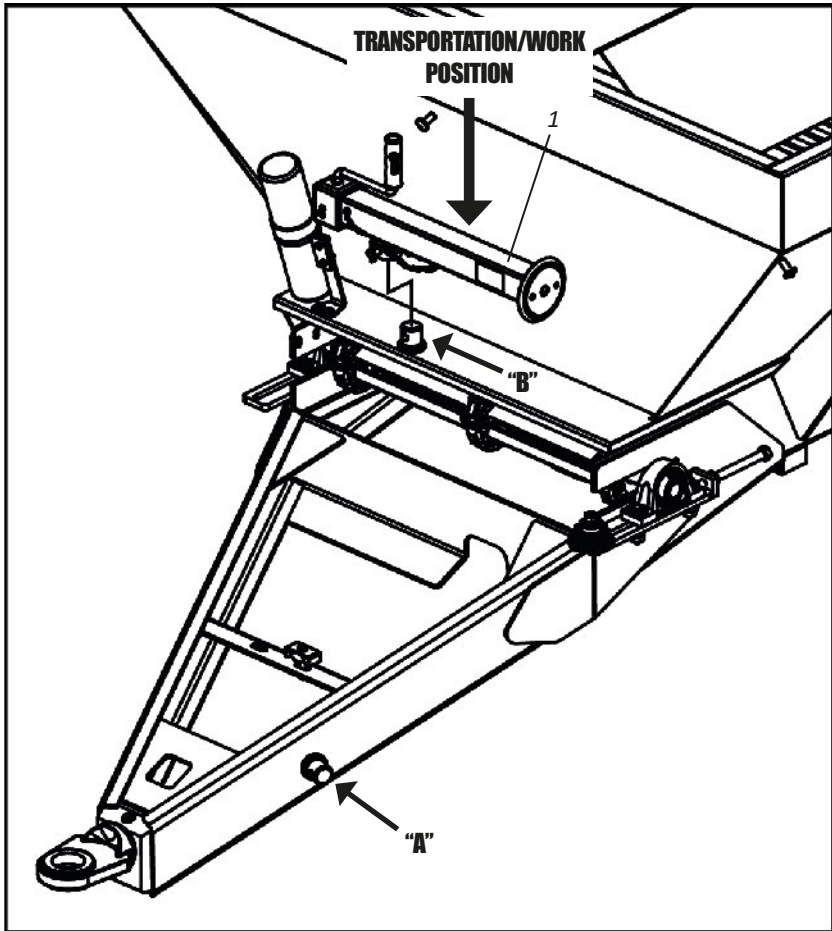
**ATTENTION**

Do not or transport the DCF-CO with the support bracket (1) at point "A". Ignoring this warning may cause severe accidents or damages.

▪ Levelling

• Distributor levelling

To level the **DCF-CO**, proceed as follows:

- 01** - First, the tractor must be in a flat location.
- 02** - Then, level the distributor, watching the longitudinal levelling (length) in relation to the ground, from the side.
- 03** - Otherwise, level it through the tractor's drawbar, using the height that results in the best **DCF-CO** levelling.

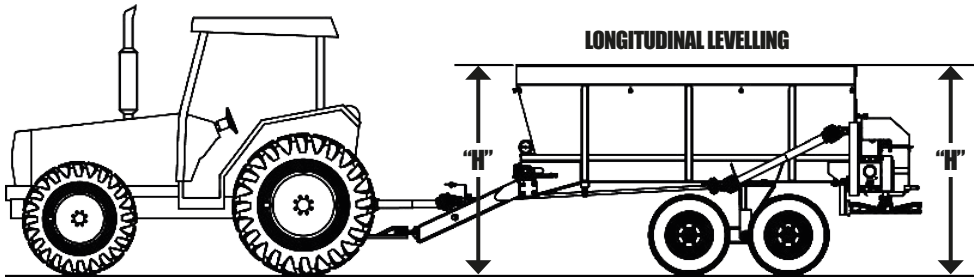

 **ATTENTION** | Read the instructions manual of the tractor and make sure of the positions in which you can work with the drawbar.

▪ Adjustment

• Cardan coupling to the TDP - DCF-CO (Cardan)

Before coupling the cardan, check the length of the tractor with respect to the tractor model that will pull the **DCF-CO**, proceeding as follows:

- 01** - First, the tractor must be in a flat location.
- 02** - Separate the cardan parts by coupling one part in the TDP and the other in the **DCF-CO**. Then, steer the tractor until one of its rear tires approaches the **DCF-CO**. Place the cardan parts side by side and check for a minimum clearance of 5 to 7 cm between the “male” and “female” parts, otherwise cut the cardan according to the instructions on the following page.

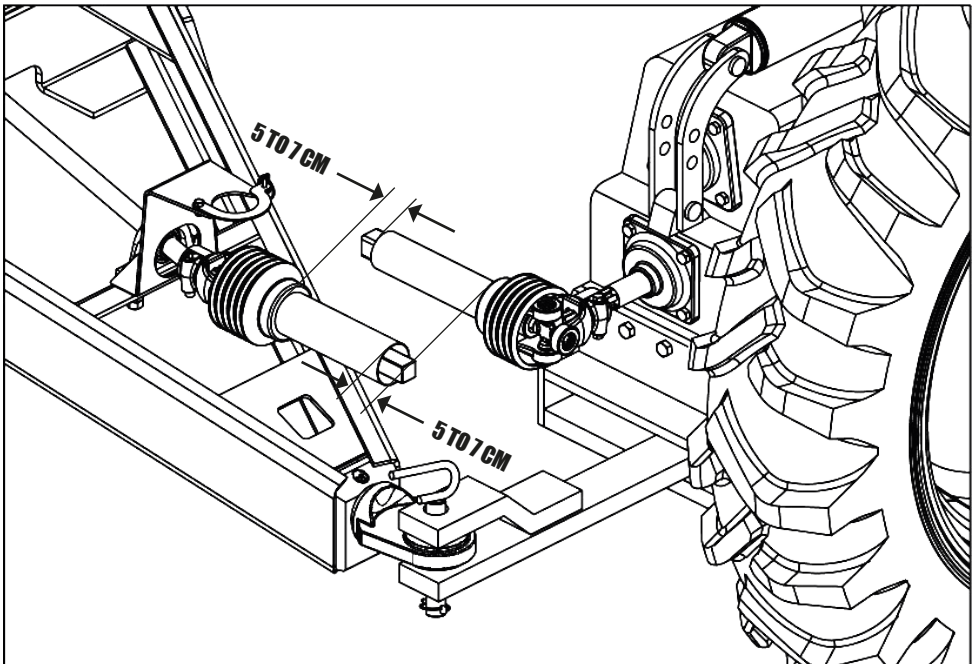

IMPORTANT

When coupling the DCF-CO, look for a safe and accessible location.
Always use low gear with low acceleration.

Before coupling the cardan, check the length of the tractor with respect to the model of the tractor that will pull the **DCF-CO (Cardan)**.

• Cardan length adjustment - DCF-CO (Cardan) - Part I

! IMPORTANT

Before cutting the cardan, check the adjustment of the tractor's drawbar, which can increase or decrease its compliance, avoiding the cardan cut.

To perform the cardan cut, proceed as follows:

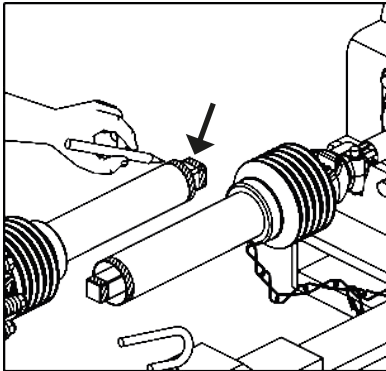

Secure the shaft halves from the shaft close to each other in the working position and mark the part to be cut.

DCF-CO (Cardan)

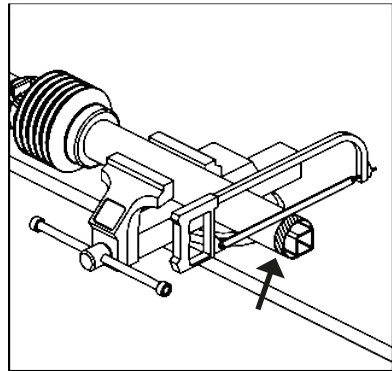

Shorten the inner and outer guards of the cardan proportionally.

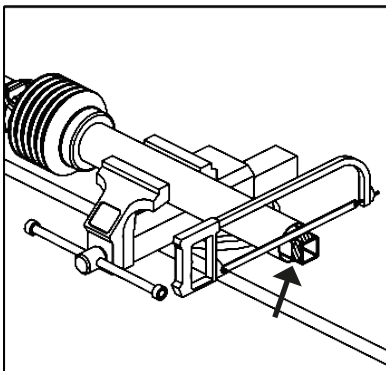

Cut the inner bars of the cardan in the same length as the protective tubes.

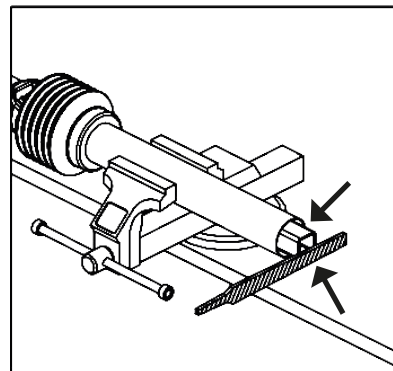

Remove all burrs and edges. Clean and grease the cardan bars.

• Cardan length adjustment - DCF-CO (Cardan) - Part II

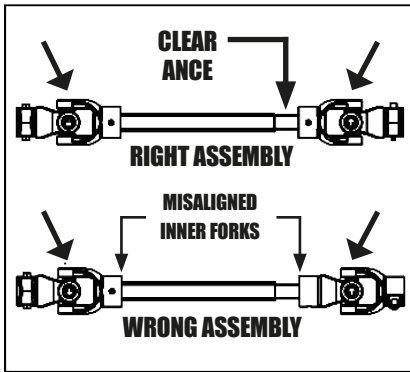

When assembling, observe that the internal and external terminals are always in the same plane, aligned. Also check the clearance on the telescopic axle, which should be of 5 to 7 cm.

DCF-CO (Cardan)

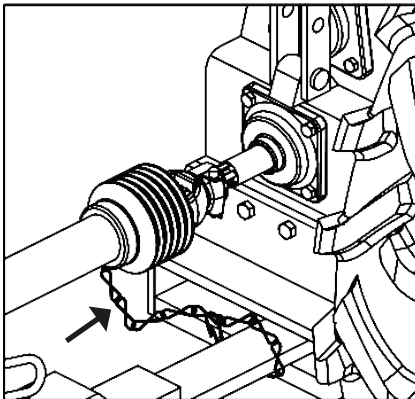

Do not connect the cardan chains while they are stretched. Keep a gap in the installation and consider angular movements.

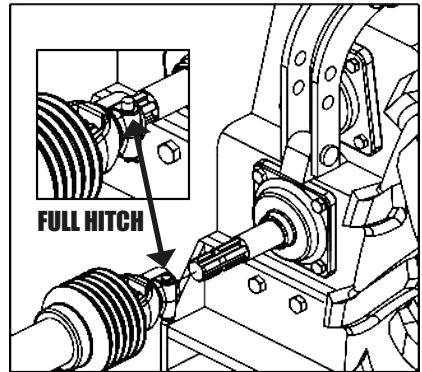

Attach the flange to TDP shaft of the tractor observing that the engagement will only be completed when lock (1) springs out.

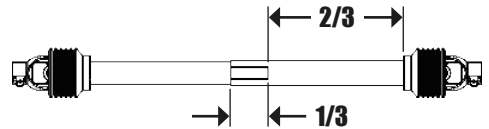

! IMPORTANT

The contact surface between the pipe and the bar must never be smaller than 1/3 of the total length.

Every time you change the tractor, check the cardan shaft length again.

NOTE

Check the cardan joint angle on page 58 and other recommendations for using it.

! ATENTION

Incorrect mounting of the cardan causes excessive vibration, which is harmful to the transmission.

When engaging the cardan in the TDP, the tractor must be switched off with the parking brake applied.

▪ Adjustments

• Belt speed - DCF-CO (Cardan) - Part I

When engaging the cardan in the TDP, the tractor must be switched off with the parking brake applied. This speed's function is feeding the discs for a uniform distribution. The **DCF-CO (Cardan)** is shipped with a **16/48** gear combination, for other combinations, proceed as follows:

01 - Loosen the lock (1), the pin (2) and remove the cardan (3).

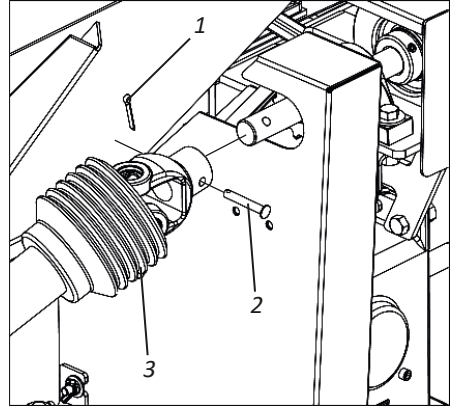

02 - Then, loose the wing nut (4) and remove cover guard (5).

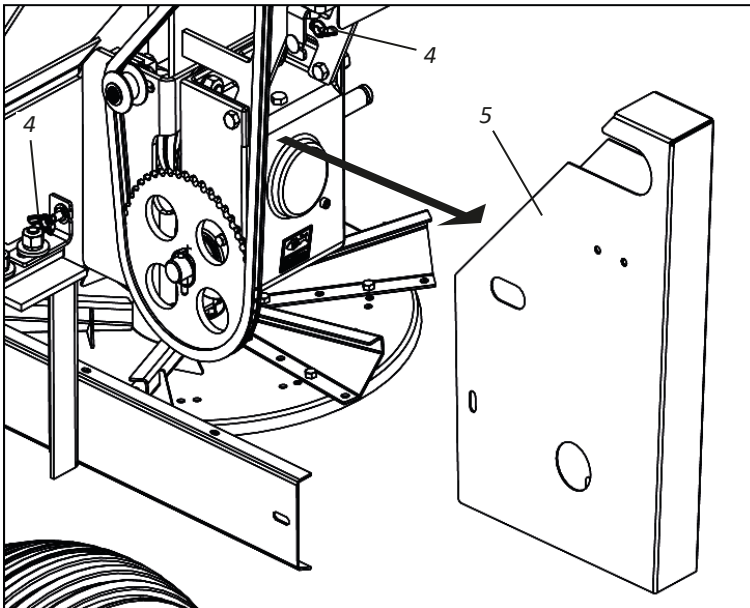

▪ Adjustments

• Belt speed - DCF-CO (Cardan) - Part II

- 03** - Then, remove the chain (6), loosen the retaining ring (7), remove the gear (8), release the ring lock (9) and remove the gear (10).
- 04** - Then, according to your need, replace gears "A" and "B" with gears "C" and "D" which are fastened to the front of the **DCF-CO (Cardan)** through the nut (11), washer (12) and flat washer (13).
- 05** - After replacing the gears, reassemble all components.

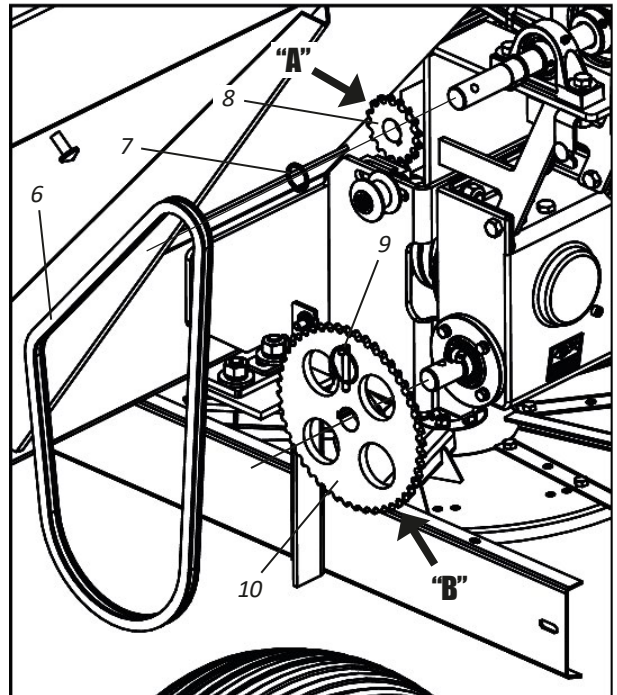
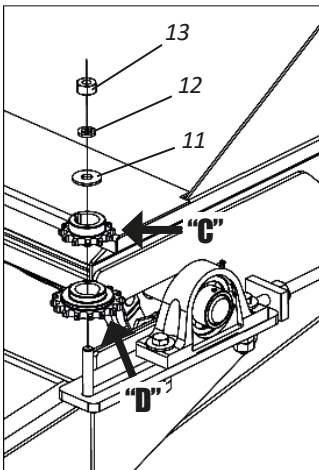

Assembly	Gears Combination	
	Motor	Moving
1	16 Teeth	48 Teeth
2	16 Teeth	16 Teeth
3	16 Teeth	12 Teeth
4	12 Teeth	48 Teeth
5	12 Teeth	16 Teeth

ATTENTION

Depending on the combination of mounted gears, decreasing the current using its splice will be necessary. Do not work with a loose chain.

▪ Adjustments

• Belt speed - DCF-CO (Hydraulic Engine) - Part I

When engaging the cardan in the TDP, the tractor must be switched off with the parking brake applied. This speed's function is feeding the discs for a uniform distribution. The **DCF-CO (Hydraulic Engine)** is shipped with a **16/48** gear combination, for the other combinations, proceed as follows:

- 01** - Loose the nut (1), lock washer (2), flat washer (3) and remove the screw (4).
- 02** - Loose the nut (5), lock washer (6), flat washer (3) and take out the screw (7).
- 03** - Then, loose the nut (8), lock washer (9), screw (10) and remove the bushing (11).

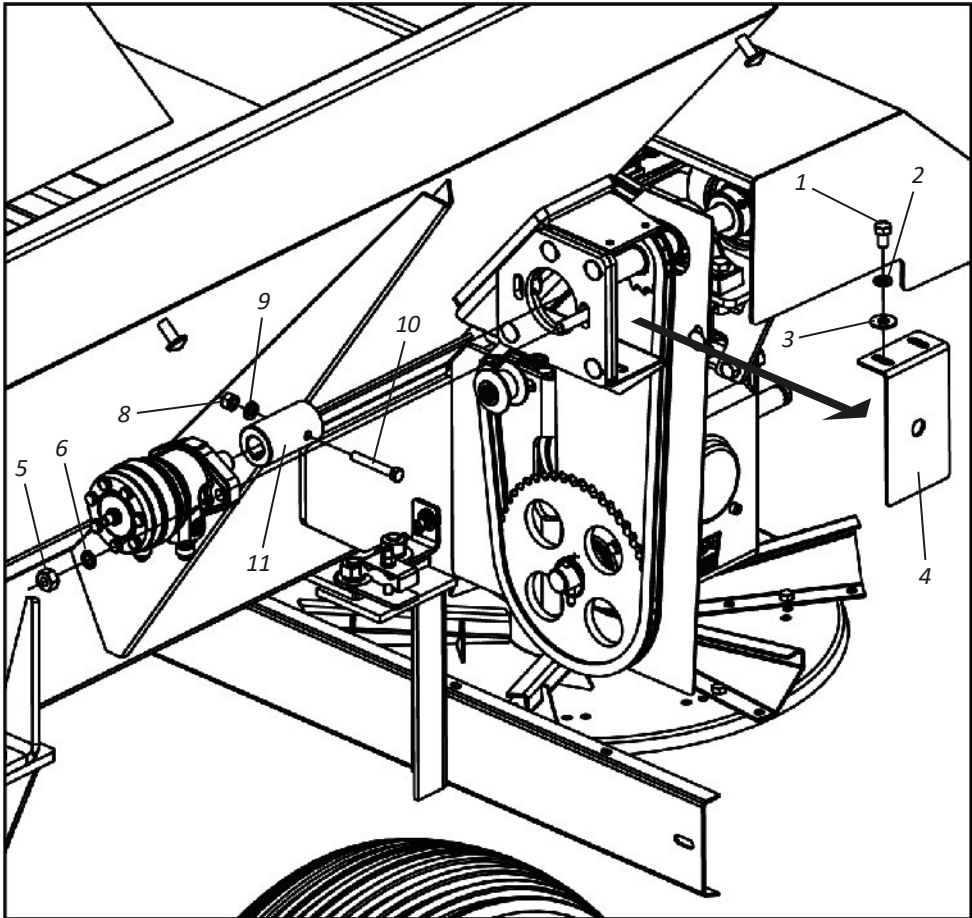

▪ Adjustments

• Belt speed - DCF-CO (Hydraulic Engine) - Part II

- 04** - Then, remove the chain (12), loosen the retaining ring (13), remove the gear (14), release the ring lock (15) and remove the gear (16).
- 05** - Then, according to your work needs, replace gears “A” and “B” with gears “C” and “D” that are attached to the front of the **DCF-CO (Hydraulic Engine)** through the nut (17), washer (18) and flat washer (19).
- 06** - After replacing the gears, reassemble all components.

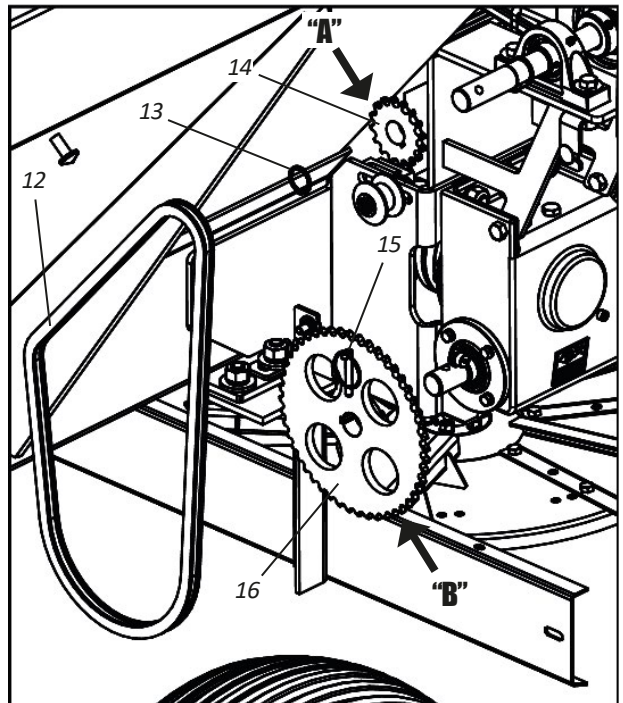
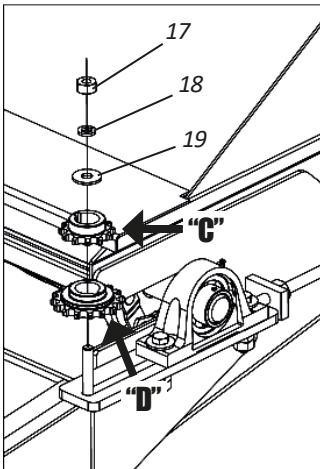

Assembly	Gears Combination	
	Motor	Moving
1	16 Dentes	48 Dentes
2	16 Dentes	16 Dentes
3	16 Dentes	12 Dentes
4	12 Dentes	48 Dentes
5	12 Dentes	16 Dentes

ATTENTION

Depending on the combination of mounted gears, decreasing the current using its splice will be necessary. Do not work with a loose chain.

▪ Adjustments

• Calibration RPM (Hydraulic Engine) - Part I

When equipped with hydraulic engine, the **DCF-CO** is accompanied by a tachometer (1). The tachometer (1) is used to calibrate the RPM of the hydraulic engine. Before the RPM calibration, proceed as follows:

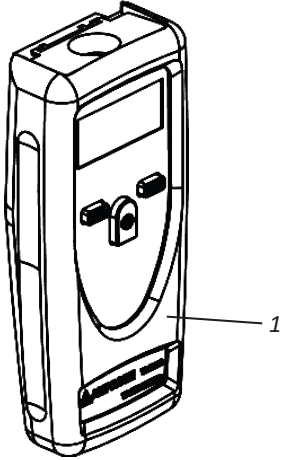

01 - Loosen the screws (2), pressure washers (3) and nuts (4).

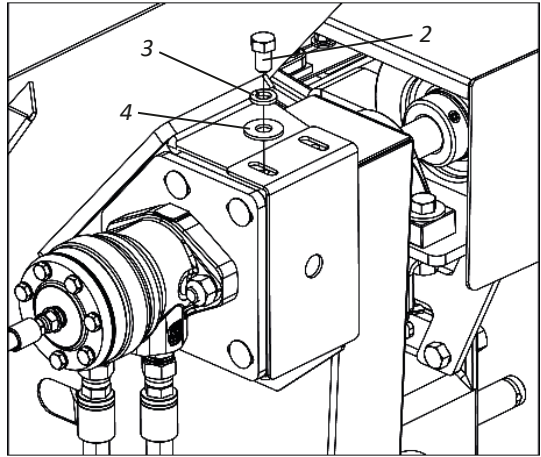

02 - Then, remove the protection plate (5).

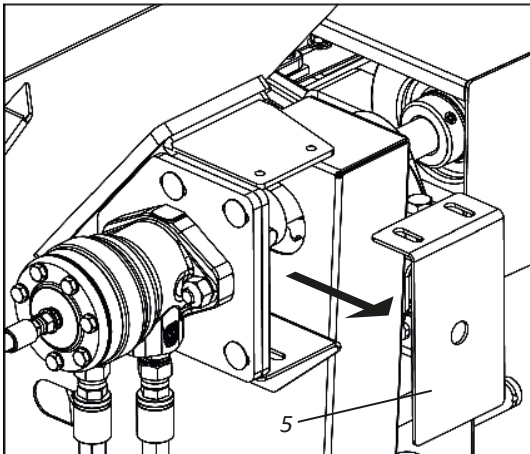

▪ Adjustments

• Calibration RPM (Hydraulic Engine) - Part II

- 03 - Then cut the sticker (6) at the size of 1 cm and glue it to the shaft (7). Finish by reinstalling the protection plate (5).

! IMPORTANT

It is necessary to glue the sticker (6) on the shaft (7) so that the tachometer (1) can perform the calibration.

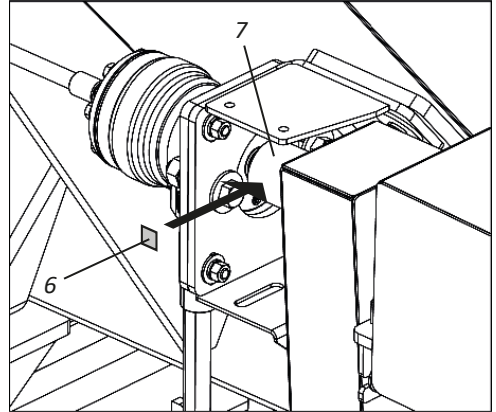

ATTENTION

Only perform the calibration after fixing the protection plate (5). Ignoring this warning may cause severe accidents or death.

Before starting work, calibrate the RPM of the hydraulic engine (8) as follows:

- 01 - First start the tractor.
- 02 - Then, approach the tachometer (1) to the hole of the guard plate (5).
- 03 - Then turn the tachometer (1) in the optical function and measure the RPM. If the result is not 540 RPM, adjust the RPM on the tractor and redo the measurement to the recommended 540 RPM for the work.

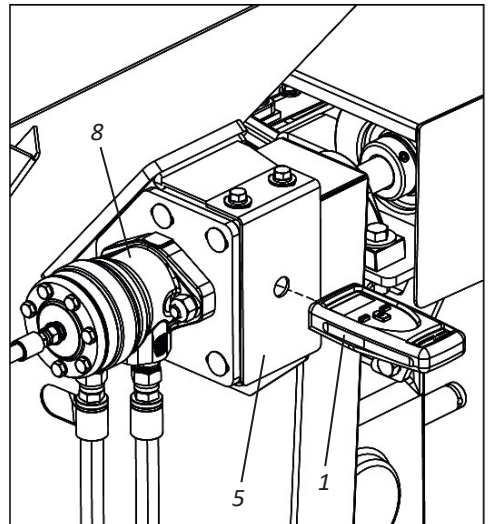

▪ Adjustments

• Conveyor tension

To adjust the conveyor (1) tension, proceed as follows:

- 01** - First, pull the power plug and turn the tractor's engine off.
- 02** - Then, make sure that the **DCF-CO** is empty, is not, empty it.
- 03** - Then, press under the belt and check for a gap of up to 50 mm from the bottom of the **DCF-CO**.
- 04** - If there is greater clearance, adjust the belt tension (1) for this, loosen the locknut (2), the nuts and locknuts (3) and adjust the tensioner (4). When adjustment is complete, retighten the nuts and locknuts (3) and the locknut (2).

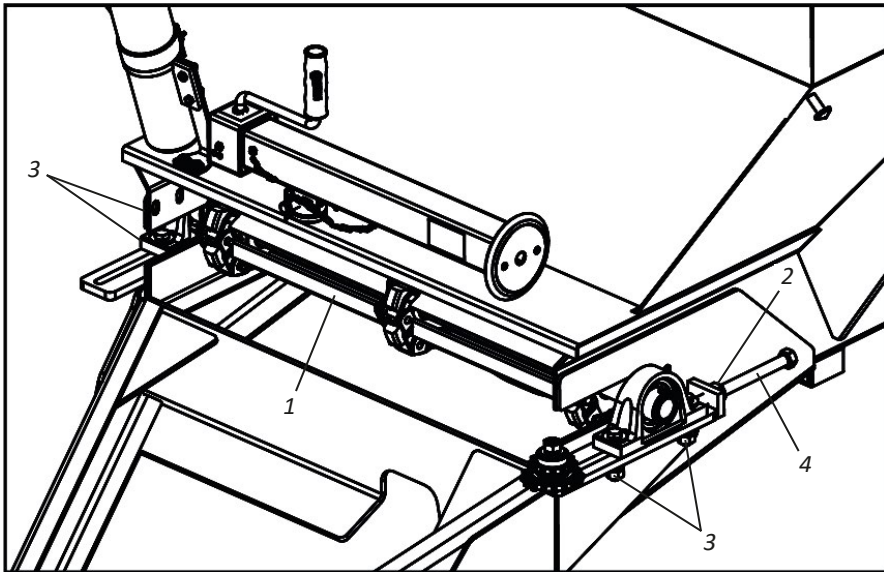

ATTENTION

When adjusting the conveyor tension, adjust both sides evenly, avoiding the conveyor misalignment. In the first hours of work, check the conveyor tension. Then, perform a daily check. When the belt tension adjustment reaches the end, one or more links must be removed, returning the tensioner to its starting position.

▪ Adjustments

• Belt tension

The chain tension (1) is performed through the tensioner (2). To adjust chain (1) tension, proceed as follows:

01 - Loosen the nut (3), slide the tensioner (2) by adjusting the chain tension (1).

02 - Then, retighten the screw (3), securing the tensioner (2).

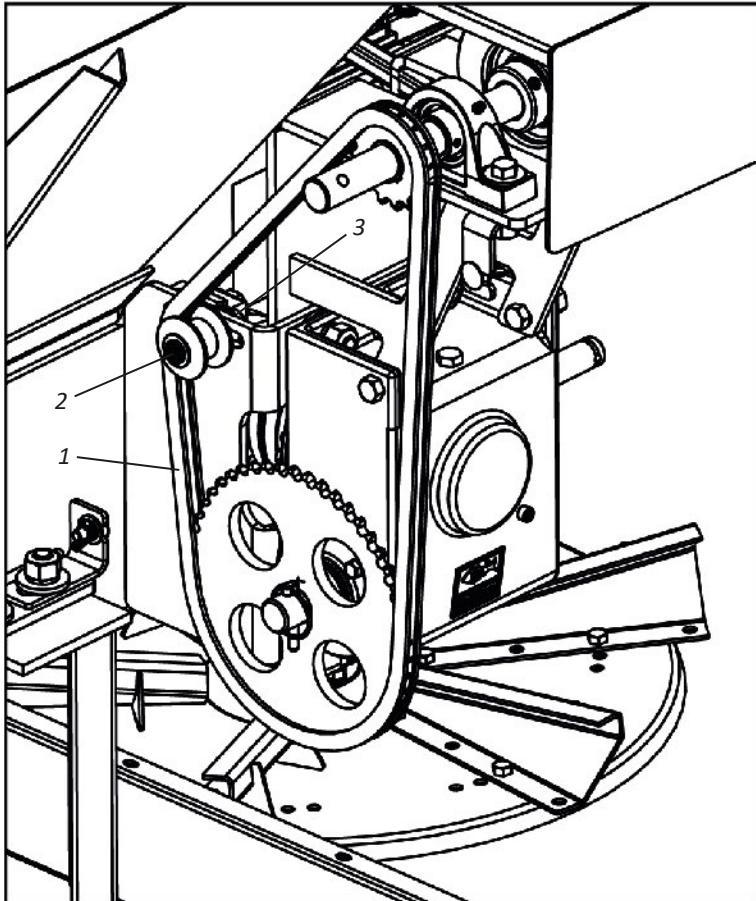

ATTENTION

Check chain tension daily, normal clearance should be ± 1 cm at its center.

▪ Adjustments

• Belt tension

To adjust the belt (1) tension, proceed as follows:

- 01 - Loosen the nut (2) of the pulley (3), along with the inner nut (4) of the tensioner (5).
- 02 - Then adjust belt tension (1) through the outer nut (6) of the tensioner (5) and then retighten the inner nut (4) and the nut (2) of the pulley (3).

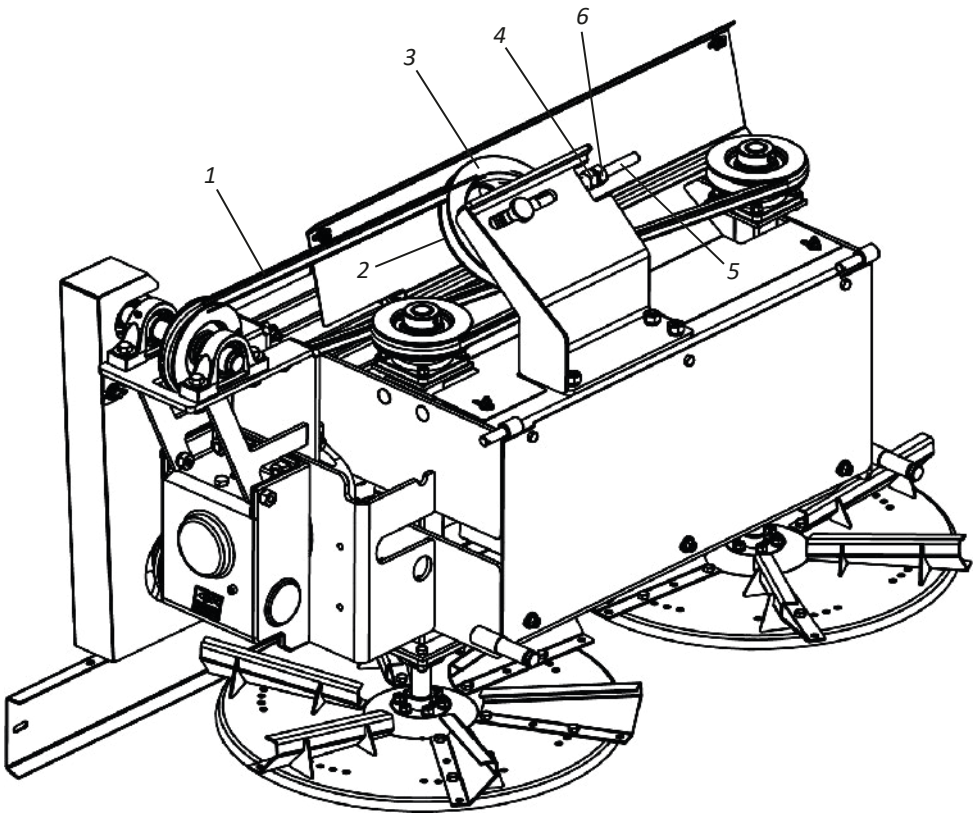

ATTENTION

In the first hours of work, check the chain tension. Then, perform a daily check. Do not run the DCF-CO with loose chains.

IMPORTANT

The allowed clearance is 3.5 cm.

▪ Adjustments

• Belt Replacement

TO REPLACE THE BELT, PROCEED AS FOLLOWS:

01 - Loosen the nuts (1) of the tensioner (2), and the nut (3) of the pulley (4). Then, remove the chain (5).

TO PLACE THE BELT, PROCEED AS FOLLOWS:

01 - Start placing the belt (5), positioning it on the "A" pulley.

02 - Then, slide the lower part of the belt (5) onto the "B" pulley from the right distributor disc.

03 - Then twist the belt (5) and thread it into the "C" pulley of the left distributor disc.

04 - Finally, pass the belt (5) through the "D" pulley of the tensioner (2).

05 - After finishing placing the belt (5), tension it, adjusting the tensioner (2) and retighten the nut (3) of the pulley (4).

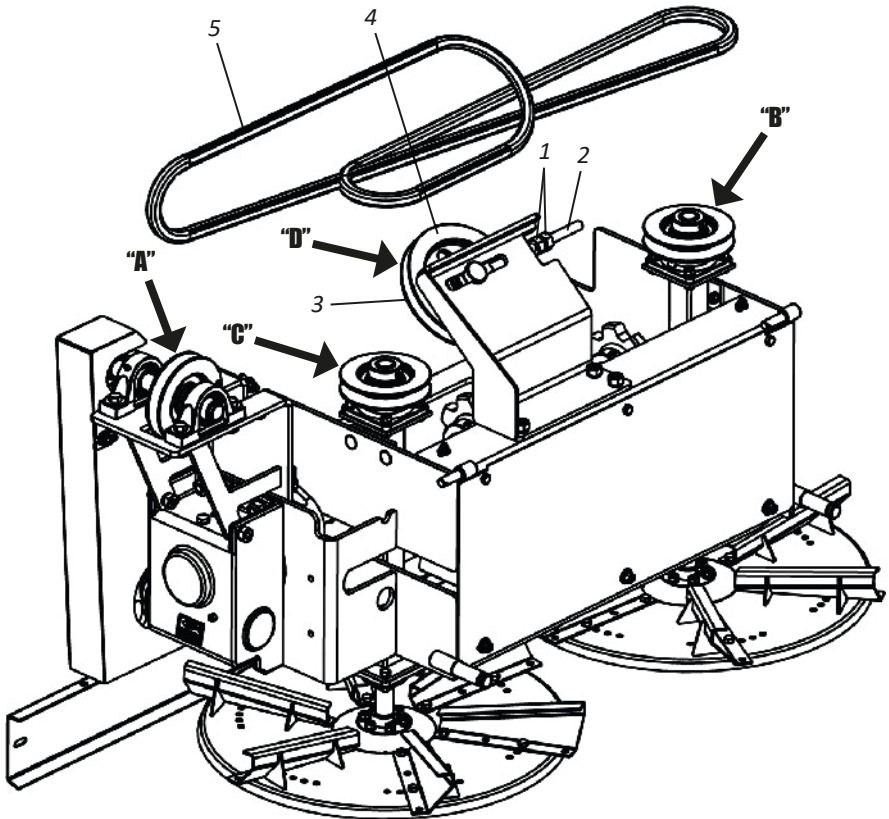

▪ Adjustments

• Shut-off gate adjustment

The DCF-CO has a gate (1) that, through a graduation scale (2), adjusts the amount of product to be distributed. To adjust the product flow, proceed as follows:

- 01 - Loosen the wing nut (3).
- 02 - Then pull the lever (4) adjusting the opening or closing of the gate (1) according to the graduated scale (2) from (0 to 22).
- 03 - Then retighten the wing nut (3).

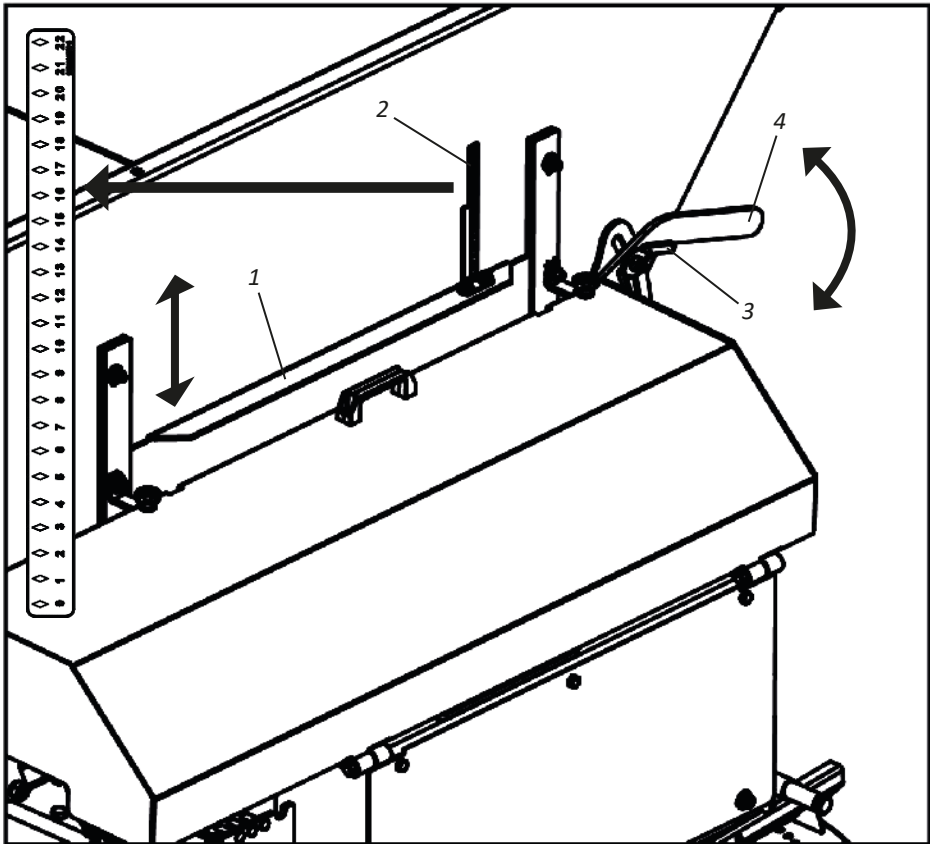

! IMPORTANT

See pages 68 to 72 for distribution tables to regulate the gate (1) and graduation scale (2).

▪ Adjustments

• Position of fins in the distributor discs

Distributor discs (1) have adjustable fins (2) for uniform distribution both at high and low dosages.

By changing the fins (2) angles, the application range with and the product direction change. To adjust the vanes (2), proceed as follows:

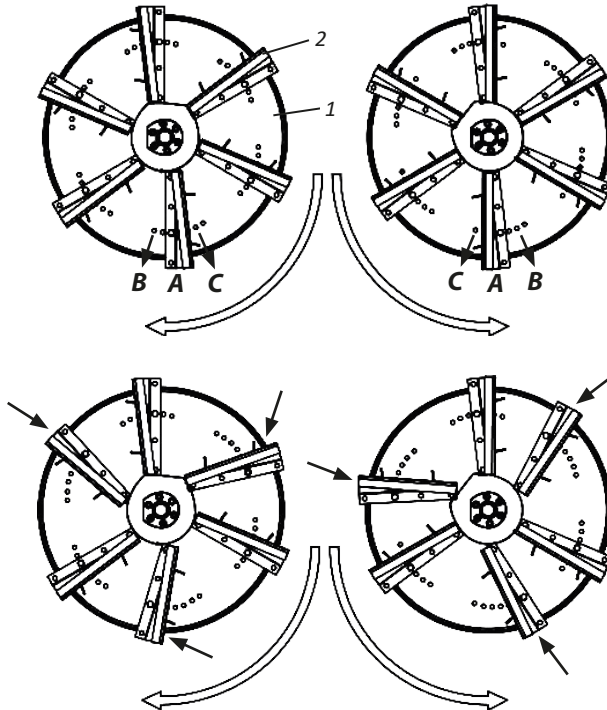

POSITION "A"

Medium distribution width and intermediate product direction.

POSITION "B"

Smaller distribution width and more centralized product direction.

POSITION "C"

Greater distribution width and product directed to the edges.

ATTENTION

If it is required to change the procedure for a part of the product for better distribution uniformity, only 3 fins may be adjusted at different angles from the others, interchangeably, changing the positions on the disc.

▪ Adjustments

• Cardan recommendations

The cardan is limited in its maximum angle of articulation. This angle, with the cardan in operation, can reach a maximum of 35° for a short period of time. In continuous work, it should not exceed 15°.

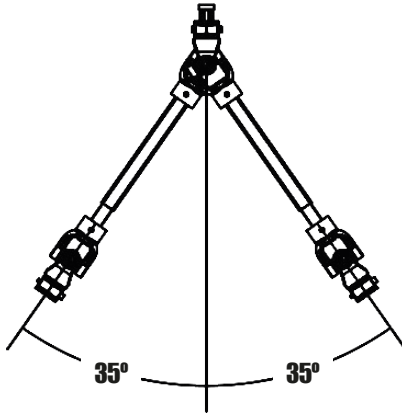

IN A SHORT PERIOD OF TIME

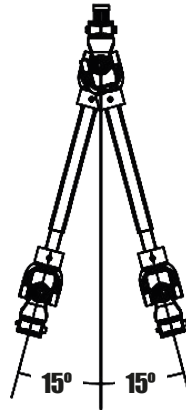

IN CONTINUOUS WORK

ATTENTION

Never engage to TDP when the joint is at an angle greater than 15°.

When maneuvering with PTO off, never exceed the pivot angle of 35 degrees, this may occur in transportation routes or maneuvers in warehouses with the coupled cardan.

Safety protection (1) is a fundamentally important component for the user's personal safety and for the cardan shaft's lifespan.

IMPORTANT

Do not work with the DCF-CO if the cardan is not with its guard (1). Ignoring this warning may cause severe accidents or cardan damages.

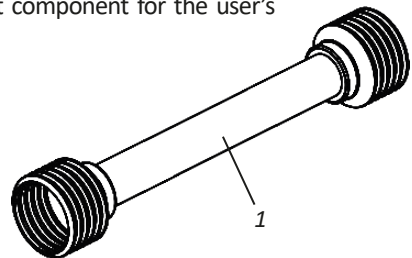

NOTE

The information on this page has been taken from the cardan manufacturer's catalog.

▪ Adjustments

• Adjustment of guide plates (Optional)

Before starting work with the driver box (1), adjust the guide plates (2) as they determine the height, i.e the distance the fertilizer will reach. To adjust the guide plates (2), proceed as follows:

01 - Loose te wing nut (3).

02 - Then adjust the guide plates (2) according to the working requirement.

- **LOWER** guide plates: The limestone, fertilizer or organic compound jet has shorter reach.
- **HIGHER** guide plates: The limestone, fertilizer or organic compound jet has longer reach.

03 - Then retighten the wing nuts (3).

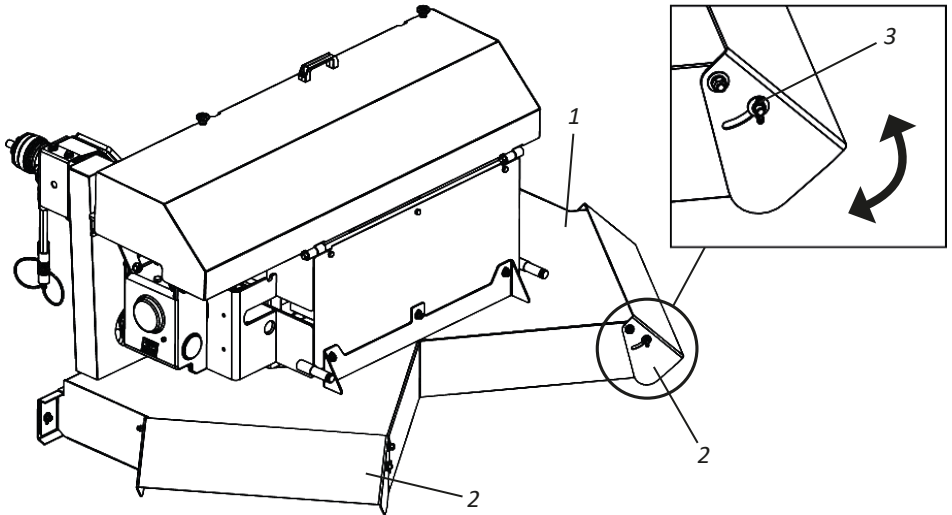

! ATTENTION

VERY LOW guide plates: They can prevent the fertilizer from reaching the base of the plants, spreading along the way.

VERY HIGH guide plates: They can release fertilizer against branches, damaging the plants.

! IMPORTANT

When adjusting the guide plates (2), try to leave them in the same position (slope).

▀ Operations

• Using the baffle

The **DCF-CO** is shipped assembled with a baffle (1). This baffle prevents the belt from overloading, allowing smoother work.

Before starting the works with **DCF-CO**, check if its baffle (1) is properly secured, tightening the washers and nuts (2) preventing the baffle (1) from coming off, damaging the conveyor and the **DCF-CO**.

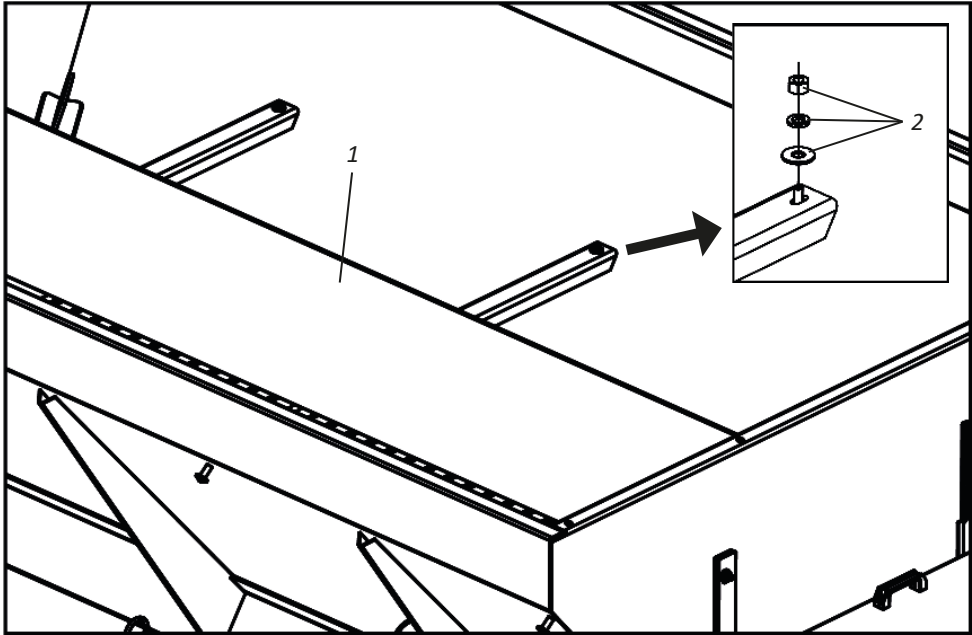

NOTE

When working with limestone, gypsum, etc., never remove the baffle (1).
When working with organic compound, the baffle (1) can be removed if necessary.

▪ Operations

• Distance between strokes

The distance between strokes must be well observed by the operator for a homogeneous distribution throughout the area. However, during the work, a variation up to 25% in the amount distributed between strokes is accepted.

We recommend a distance of 7 meters between strokes for the distribution of dry limestone and gypsum. For organic compound, the distance between strokes may vary according to the type of organic compound.

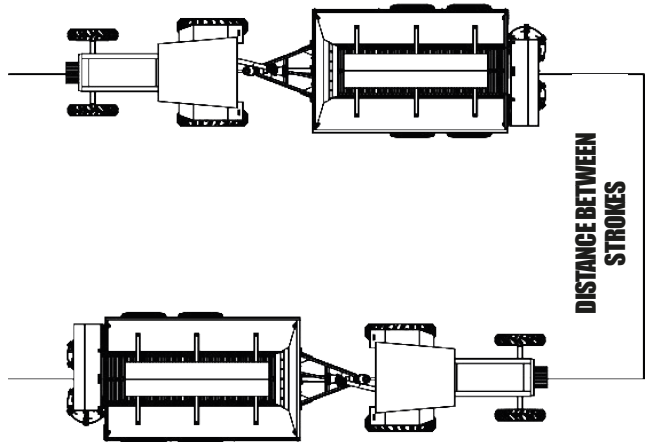

! ATTENTION

Keep people and animals clear during work.

! IMPORTANT

We do not recommend increasing the distance between strokes.

• Overlapping

Overlapping is covering a product being distributed to the edge of the track immediately before the current track, this is done to compensate for the distribution deficiency that occurs naturally at the edges.



! ATTENTION

Do not perform adjustments while the DCF-CO is in motion or with an active transmission.

▀ Operations

• Working with the driver box (Optional)

The standard version of the **DCF-CO** releases limestone, fertilizer, and organic compound in several directions through the distribution discs, delivering a uniform application throughout the area. Optionally, the **DCF-CO** can be acquired with a driving box for in line fertilizer application, for example under the base of the trees.

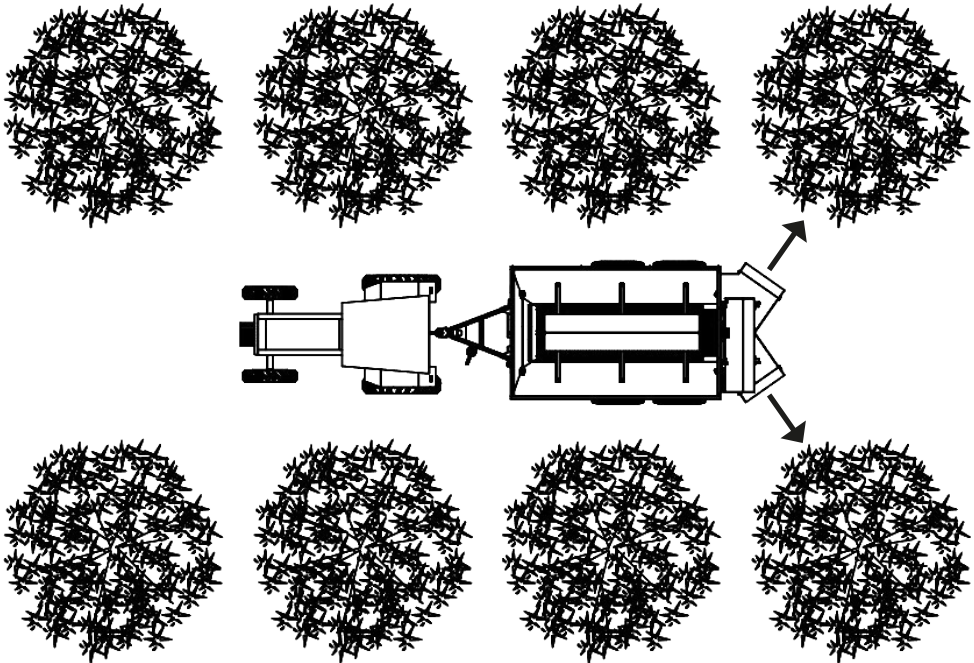

ATTENTION

To regulate the distribution of the driver box, proceed as per page 59.

▀ Operations

• Working with canvas or rubber baffle (Optional)

The standard version of the **DCF-CO** releases limestone, fertilizer and organic compound in several directions through the distribution discs, providing a uniform application throughout the area. Optionally the **DCF-CO** may be purchased with a baffle (canvas or rubber) for the distribution of powdered products mainly when there are occurrences of winds. Using a baffle (canvas or rubber), ensures greater uniformity in the distribution, retaining the product.

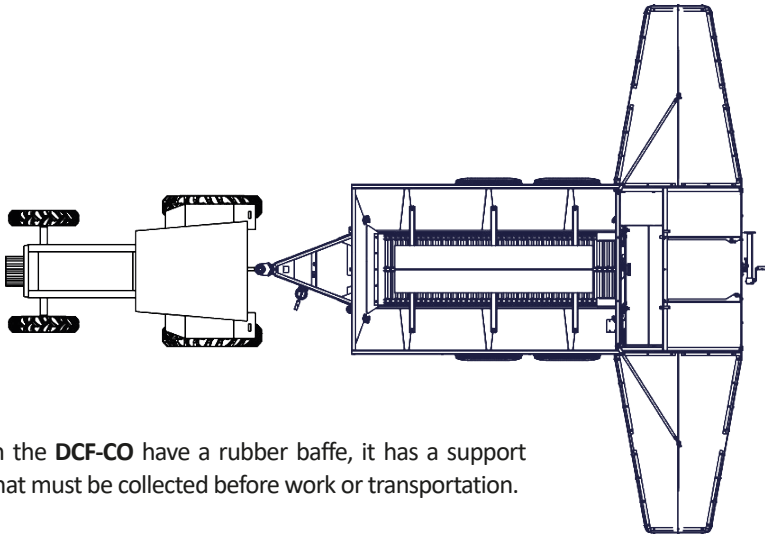

When the **DCF-CO** have a rubber baffle, it has a support bracket that must be collected before work or transportation.

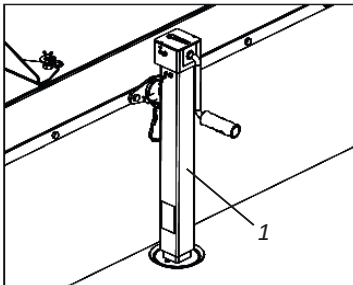

OFF POSITION

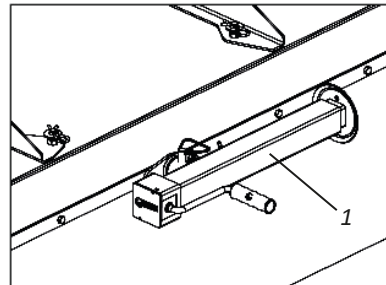

WORK OR TRANSPORT POSITION



Do not work or transport the **DCF-CO** with a rubber baffle without first pulling the support bracket (1). Ignoring this warning may cause severe accidents or damages.

▀ Operations

• Transport with canvas or rubber baffle (Optional)

To transport the DCF-CO with a baffle (canvas or rubber), lift the side frames of the baffle as follows:

01 - Remove the locks (1), flat washers (2) and uncouple the regulator (3) from the trolley (4).

02 - Then, lift the side frames (5), couple the adjuster (3) to the central frame (6) and fix it through plain washers (7) and lock (8).

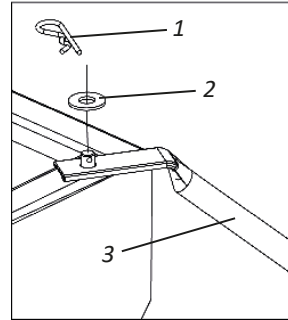

TRANSPORTATION POSITION

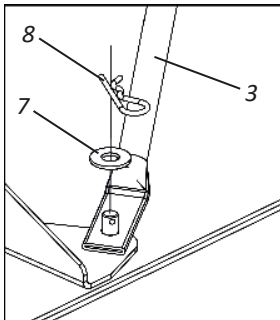
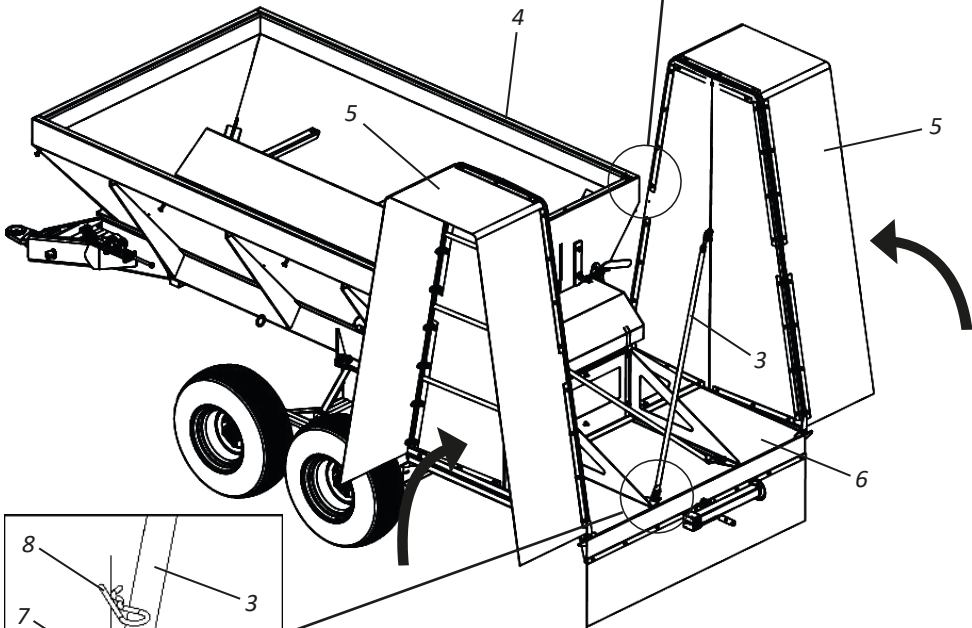

ATTENTION

Do not transport the DCF-CO with a baffle (canvas or rubber) without first lifting the side frames. Ignoring this warning may cause severe accidents or damages.

▀ Operations

• Recommendations for the operation

Preparing the **DCF-CO** and tractor will save you time and provide a better result in field work. The following suggestions may be useful for you.

GENERAL RECOMMENDATION - PART I

- 01** - Adjust the tractor according to the content of the instruction manual, always using front and rear weights to stabilize the equipment.
- 02** - Always couple to the tractor in low gear and very carefully.
- 03** - Check that the **DCF-CO** coupling is complete and leveled. Place the support bracket in the transport position and maintain the drawbar of the tractor fastened.
- 04** - After hitching, the next adjustments will be made directly in the field of work, analyzing the terrain for its texture, humidity, and types of operations to be performed with the **DCF-CO**.
- 05** - Observe the working and transport speeds specified on page 10. We do not recommend exceeding speeds to maintain service efficiency and avoid damage to the **DCF-CO**.
- 06** - During work or transport, the tractor's drawbar must remain fastened.
- 07** - Never transport or work with an overloaded **DCF-CO**.
- 08** - Before starting work, do a thorough review in the **DCF-CO**. Crossheads should be lubricated, check the oil level of the multiplier box and retighten nuts and screws. Also check the locking of pins and cotter pins.
- 09** - The ideal rotation is 540 rpm in TDP. Check the corresponding rotation on the engine, in the tractor manual. This traction engine rotation changes from tractor to tractor.
- 10** - Always observe the operation of the limestone distributing mechanisms and the settings established at the start of the work as well.
- 11** - When performing any maintenance in the **DCF-CO**, its engine must be switched off.
- 12** - Check the conveyor and transmission belt tension.
- 13** - Do not make sharp turns with the **DCF-CO** during work.
- 14** - The **DCF-CO** has several settings, but only local conditions can determine the best setting.
- 15** - Check the correct tire calibration of the **DCF-CO** according to tire model on page 73.
- 16** - Before fueling the **DCF-CO**, check that there are no objects inside the trolley, such as sticks, stones, sack, canvas, parts, etc. Make sure the product you are using does not contain foreign objects.
- 17** - Observe the lubrication interval.
- 18** - During the whole work, maintain the engine at constant rotation, avoiding an average speed variation in the tractor to prevent inefficiency or product distribution failure.
- 19** - The distance between strokes should be constant so that the distribution uniformity is not compromised.

▪ Operations

GENERAL RECOMMENDATION - PART II

- 20** - To engage or uncouple the cardan, the TDP must be switched off.
- 21** - The weight of the product is related to its granulometry and density.
- 22** - The distributor operates more efficiently within the 5-7 km/h range.

When in doubt, never operate or handle the DCF-CO, contact After Sales.
Telephone: 0800-152577 / E-mail: posvenda@baldan.com.br

▪ Calculation

• Work speed calculation

In order to calculate the speed, proceed as follows:

- 01** - Fill the **DCF-CO's** tank up to half capacity with the product to be applied.
- 02** - Then place two spaced marks at 100 meters in the application area.
- 03** - Then, calculate the time the tractor took to travel the distance while the **DCF-CO** is coupled.
- 04** - The calculated the measured time in kilometers (km) using the following formula:

Km/hr = distance travelled / time spent in seconds x 3,6 (conversion factor of m/s to Km/hr).

Example:

Km/hr = 100 / 60s x 3,6 = 6 Km/h

• Fertilizer dosage calculation per minute

To perform the calculation, turn off the distributor discs, remove the belt, start the **DCF-CO** at 540 rpm and keep it in place. Then collect the product by measuring the time.

Formula: $S = \frac{VT \times LT \times D}{600}$

Formula Data: **S** = Product output (Kg/min).

VT = Work speed (Km/h).

LT = Working width (Application range).

D = Dosage (Kg/ha).

600 = Unit conversion factor.

Example: $S = \frac{6 \times 12 \times 300}{600} = 36 \text{ (Kg/min)}.$

▪ Distribution system

• Limestone distribution table - Kg/Ha - DCF-CO (Cardan and Hydraulic Engine)

Gears: Motor 16 teeth Moving 48 teeth		Rotation PTO 540 RPM						
Scale Opening	Amount of Kg/Minute	Wind speed						
		4 km/h	5 km/h	6 km/h	7 km/h	8 km/h	9 km/h	10 km/h
		Amount of kg per Hectare						
0	32	401	321	268	229	201	178	161
1	40	503	402	335	287	251	223	201
2	55	686	549	458	392	343	305	275
3	70	878	702	585	501	439	390	351
4	85	1058	846	705	604	529	470	423
5	98	1230	984	820	703	615	547	492
6	111	1393	1114	928	796	696	619	557
7	125	1564	1251	1043	894	782	695	626
8	139	1735	1388	1157	992	868	771	694
9	153	1907	1525	1271	1090	953	847	763
10	166	2078	1663	1385	1188	1039	924	831
11	180	2250	1800	1500	1286	1125	1000	900
12	194	2421	1937	1614	1383	1211	1076	968
13	207	2593	2074	1728	1481	1296	1152	1037
14	221	2764	2211	1843	1579	1382	1228	1106
15	235	2935	2348	1957	1677	1468	1305	1174
16	249	3107	2485	2071	1775	1553	1381	1243
17	262	3278	2623	2185	1873	1639	1457	1311
18	276	3450	2760	2300	1971	1725	1533	1380
19	290	3621	2897	2414	2069	1811	1609	1448
20	303	3793	3034	2528	2167	1896	1686	1517
21	317	3964	3171	2643	2265	1982	1762	1586
22	331	4135	3308	2757	2363	2068	1838	1654



ATTENTION

Due to different granulometry and specific weights from the applied products, variations can be observed in relation to the presented table. We recommend performing the practical tests described in page 67 before application.



NOTE

The table was elaborated with 540 rpm in the PTO and transmission ratio (motor/moving).

▪ Distribution system

• Limestone distribution table - Kg/Ha - DCF-CO (Cardan and Hydraulic Engine)

Gears: Motor 12 teeth Moving 48 teeth		Rotation PTO 540 RPM						
Scale Opening	Amount of Kg/Minute	Wind speed						
		4 km/h	5 km/h	6 km/h	7 km/h	8 km/h	9 km/h	10 km/h
		Amount of kg per Hectare						
0	24	301	241	201	172	150	134	120
1	30	377	302	251	215	188	168	151
2	41	515	412	343	294	257	229	206
3	53	658	527	439	376	329	293	263
4	63	793	635	529	453	397	353	317
5	74	923	738	615	527	461	410	369
6	84	1044	836	696	597	522	464	418
7	94	1173	938	782	670	586	521	469
8	104	1302	1041	868	744	651	578	521
9	114	1430	1144	953	817	715	636	572
10	125	1559	1247	1039	891	779	693	623
11	135	1687	1350	1125	964	844	750	675
12	145	1816	1453	1211	1038	908	807	726
13	156	1944	1556	1296	1111	972	864	778
14	166	2073	1658	1382	1185	1036	921	829
15	176	2202	1761	1468	1258	1101	978	881
16	186	2330	1864	1553	1331	1165	1036	932
17	197	2459	1967	1639	1405	1229	1093	983
18	207	2587	2070	1725	1478	1294	1150	1035
19	217	2716	2173	1811	1552	1358	1207	1086
20	228	2844	2276	1896	1625	1422	1264	1138
21	238	2973	2378	1982	1699	1486	1321	1189
22	248	3102	2481	2068	1772	1551	1378	1241



ATTENTION

Due to different granulometry and specific weights from the applied products, variations can be observed in relation to the presented table. We recommend performing the practical tests described in page 67 before application.



NOTE

The table was elaborated with 540 rpm in the PTO and transmission ratio (motor/moving).

▪ Distribution system

• Limestone distribution table - Kg/Ha - DCF-CO (Cardan and Hydraulic Engine)

Gears: Motor 12 teeth Moving 16 teeth		Rotation PTO 540 RPM						
Scale Opening	Amount of kg/Minute	Wind speed						
		4 km/h	5 km/h	6 km/h	7 km/h	8 km/h	9 km/h	10 km/h
		Amount of Kg per Hectare						
0	72	903	722	602	516	451	401	361
1	90	1131	905	754	646	565	503	452
2	124	1544	1235	1029	882	772	686	618
3	158	1974	1580	1316	1128	987	878	790
4	190	2379	1904	1586	1360	1190	1058	952
5	221	2768	2214	1845	1581	1384	1230	1107
6	251	3133	2507	2089	1790	1567	1393	1253
7	282	3519	2815	2346	2011	1759	1564	1408
8	312	3905	3124	2603	2231	1952	1735	1562
9	343	4290	3432	2860	2452	2145	1907	1716
10	374	4676	3741	3117	2672	2338	2078	1870
11	405	5062	4049	3374	2892	2531	2250	2025
12	436	5447	4358	3632	3113	2724	2421	2179
13	467	5833	4667	3889	3333	2917	2593	2333
14	498	6219	4975	4146	3554	3109	2764	2488
15	528	6605	5284	4403	3774	3302	2935	2642
16	559	6990	5592	4660	3994	3495	3107	2796
17	590	7376	5901	4917	4215	3688	3278	2950
18	621	7762	6209	5174	4435	3881	3450	3105
19	652	8147	6518	5432	4656	4074	3621	3259
20	683	8533	6827	5689	4876	4267	3793	3413
21	714	8919	7135	5946	5096	4459	3964	3568
22	744	9305	7444	6203	5317	4652	4135	3722



Due to different granulometry and specific weights from the applied products, variations can be observed in relation to the presented table. We recommend performing the practical tests described in page 67 before application.



The table was elaborated with 540 rpm in the PTO and transmission ratio (motor/moving).

▪ Distribution system

• Limestone distribution table - Kg/Ha - DCF-CO (Cardan and Hydraulic Engine)

Gears: Motor 16 teeth Moving 16 teeth		Rotation PTO 540 RPM						
Scale Opening	Amount of kg/Minute	Wind speed						
		4 km/h	5 km/h	6 km/h	7 km/h	8 km/h	9 km/h	10 km/h
		Amount of Kg per Hectare						
0	91	1144	915	762	653	572	508	457
1	115	1432	1146	955	818	716	637	573
2	156	1956	1565	1304	1118	978	869	782
3	200	2501	2001	1667	1429	1250	1112	1000
4	241	3014	2411	2009	1722	1507	1340	1206
5	280	3506	2804	2337	2003	1753	1558	1402
6	317	3969	3175	2646	2268	1984	1764	1587
7	357	4457	3566	2971	2547	2229	1981	1783
8	396	4946	3957	3297	2826	2473	2198	1978
9	435	5434	4347	3623	3105	2717	2415	2174
10	474	5923	4738	3949	3385	2961	2632	2369
11	513	6411	5129	4274	3664	3206	2850	2565
12	552	6900	5520	4600	3943	3450	3067	2760
13	591	7389	5911	4926	4222	3694	3284	2955
14	630	7877	6302	5251	4501	3939	3501	3151
15	669	8366	6693	5577	4780	4183	3718	3346
16	708	8854	7083	5903	5060	4427	3935	3542
17	747	9343	7474	6229	5339	4671	4152	3737
18	787	9831	7865	6554	5618	4916	4370	3933
19	826	10320	8256	6880	5897	5160	4587	4128
20	865	10809	8647	7206	6176	5404	4804	4323
21	904	11297	9038	7531	6456	5649	5021	4519
22	943	11786	9429	7857	6735	5893	5238	4714



ATTENTION

Due to different granulometry and specific weights from the applied products, variations can be observed in relation to the presented table. We recommend performing the practical tests described in page 67 before application.



NOTE

The table was elaborated with 540 rpm in the PTO and transmission ratio (motor/moving).

▪ Distribution system

• Limestone distribution table - Kg/Ha - DCF-CO (Cardan and Hydraulic Engine)

Gears: Motor 16 teeth Moving 12 teeth		Rotation PTO 540 RPM						
Scale Opening	Amount of kg/Minute	Wind speed						
		4 km/h	5 km/h	6 km/h	7 km/h	8 km/h	9 km/h	10 km/h
		Amount of Kg per Hectare						
0	119	1487	1189	991	850	743	661	595
1	149	1862	1489	1241	1064	931	827	745
2	203	2543	2034	1695	1453	1271	1130	1017
3	260	3251	2601	2167	1858	1626	1445	1300
4	313	3918	3134	2612	2239	1959	1741	1567
5	365	4557	3646	3038	2604	2279	2025	1823
6	413	5159	4127	3439	2948	2580	2293	2064
7	464	5794	4635	3863	3311	2897	2575	2318
8	514	6429	5144	4286	3674	3215	2858	2572
9	565	7065	5652	4710	4037	3532	3140	2826
10	616	7700	6160	5133	4400	3850	3422	3080
11	667	8335	6668	5557	4763	4167	3704	3334
12	718	8970	7176	5980	5126	4485	3987	3588
13	768	9605	7684	6403	5489	4803	4269	3842
14	819	10240	8192	6827	5852	5120	4551	4096
15	870	10875	8700	7250	6215	5438	4834	4350
16	921	11511	9209	7674	6578	5755	5116	4604
17	972	12146	9717	8097	6940	6073	5398	4858
18	1022	12781	10225	8521	7303	6390	5680	5112
19	1073	13416	10733	8944	7666	6708	5963	5366
20	1124	14051	11241	9367	8029	7026	6245	5620
21	1175	14686	11749	9791	8392	7343	6527	5875
22	1226	15321	12257	10214	8755	7661	6810	6129



Due to different granulometry and specific weights from the applied products, variations can be observed in relation to the presented table. We recommend performing the practical tests described in page 67 before application.



The table was elaborated with 540 rpm in the PTO and transmission ratio (motor/moving).

▪ Maintenance

The **DCF-CO** has been developed to provide you with maximum yield under land conditions. Experience has shown that periodic maintenance of certain parts of the **DCF-CO** is the best way to avoid problems, so we suggest checks.

• Tires pressure

The tires should always be properly calibrated avoiding early wear due to excess or lack of pressure.

STANDARD: TIRES 750 X 16 PLY

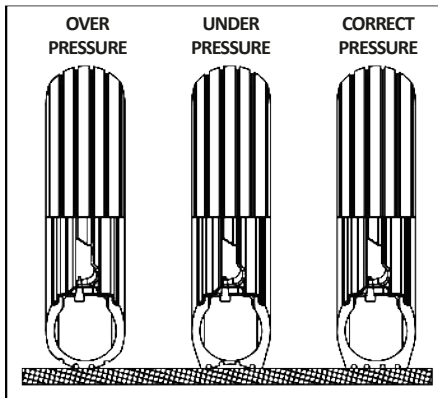

USE: 60 LBS/POL²

OPTIONAL: TIRES 11L 15

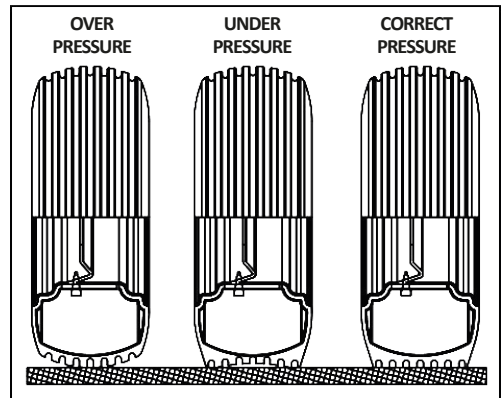

USE: 52 LBS/POL²

ATTENTION

Never weld the wheel while the tire is mounted as the heat may increase air pressure and cause the tire to explode.

When filling the tire, position yourself besides the tire, never in front of it. To inflate a tire, always use a containment device (inflation cage).

Assemble the tires with proper equipment. The service should only be performed by people qualified for the work.

Model	Standard Tires	Optimal Tires
DCF-CO 3000	750x16	11L-15
DCF-CO 6000	750x16	11L-15
DCF-CO 8000	11L-15	-

IMPORTANT

When calibrating tires, do not exceed the recommended calibration.

NOTE

The pressure of the tractor tires should be performed according to the manufacturer's recommendation.

▪ Maintenance

• Lubrification

Lubrification is essential for good performance and durability of the **DCF-CO's** moving parts, saving maintenance costs.

Before starting the operation, carefully lubricate all grease cups, always observing the lubrication intervals in the following pages. Make sure of the lubricant quality regarding its efficiency and purity, avoiding products contaminated by water, dust and other agents.

• Table of greases and equivalents

Manufacturer	Types of grease recommended
Petrobrás	Lubrax GMA-2
Atlantic	Litholine MP 2
Ipiranga	Ipiflex 2
Castrol	LM 2
Mobil	Grease MP
Texaco	Marfak 2
Shell	Alvania EP 2
Esso	Multi H
Bardahl	Maxlub APG-2EP
Valvoline	Palladium MP-2
Petronas	Tutela Jota MP 2 EP
	Tutela Alfa 2K
	Tutela KP 2K

 **ATTENTION** | For equivalent manufacturers and/or brands that are not listed in the table, consult the manufacturer's technical manual.

▪ Maintenance

- Lubrification every 5 hours of work

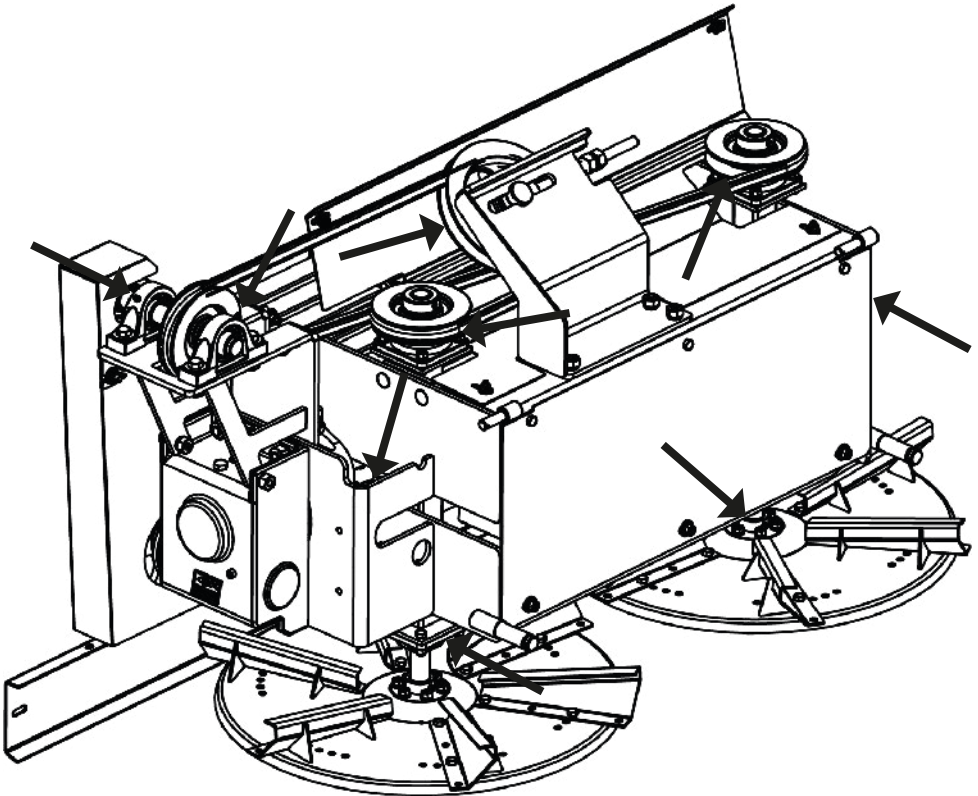
**ATTENTION**

When lubricating the DCF-CO, do not exceed the amount of new grease. Put an adequate amount.

▪ Maintenance

- Lubrication every 8 hours of work

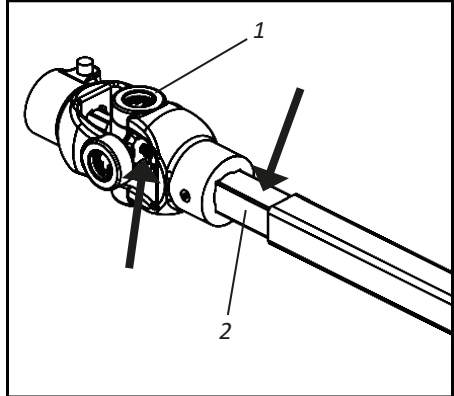
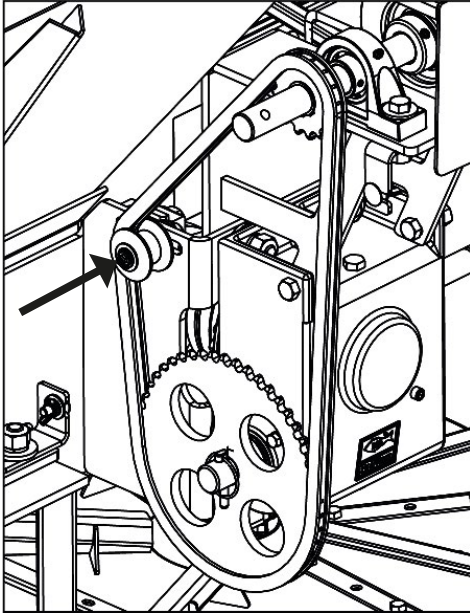

Lubricate the crossheads (1) with grease at 8-hour intervals.

The telescopic axle (2) must be lubricated weekly.

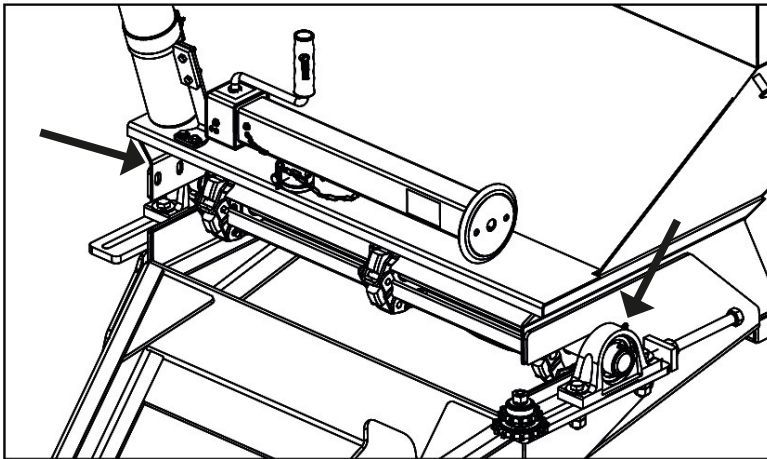

ATTENTION

When lubricating the DCF-CO, do not exceed the amount of new grease. Put an adequate amount.

▪ Maintenance

- Lubrication every 8 hours of work

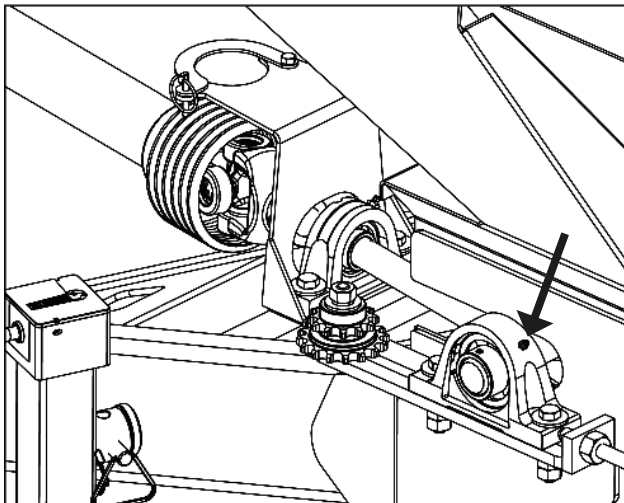
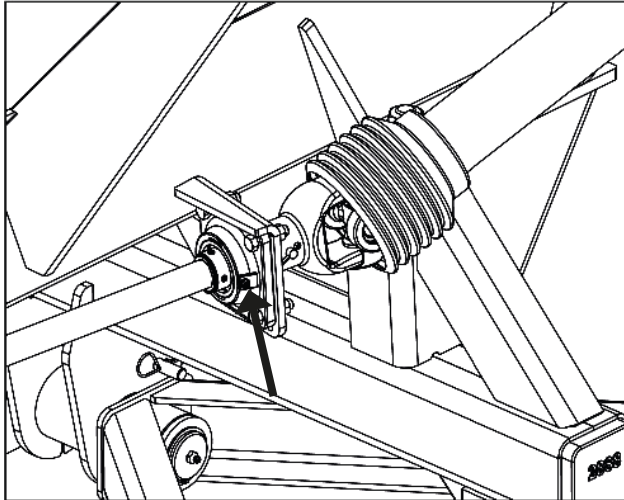
**ATTENTION**

When lubricating the DCF-CO, do not exceed the amount of new grease. Put an adequate amount.

▪ Maintenance

- Lubrication every 8 hours of work

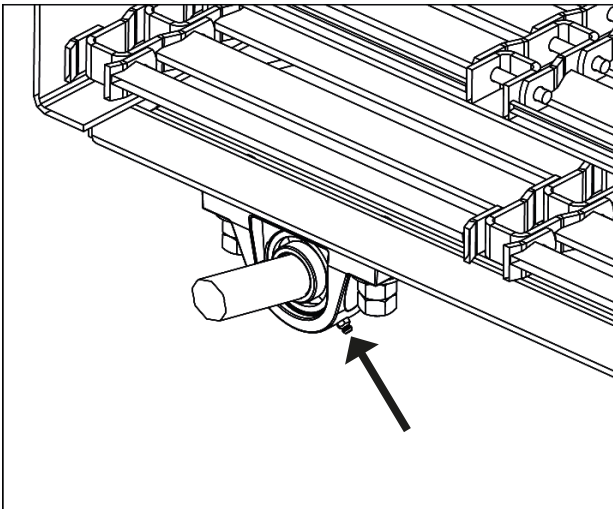
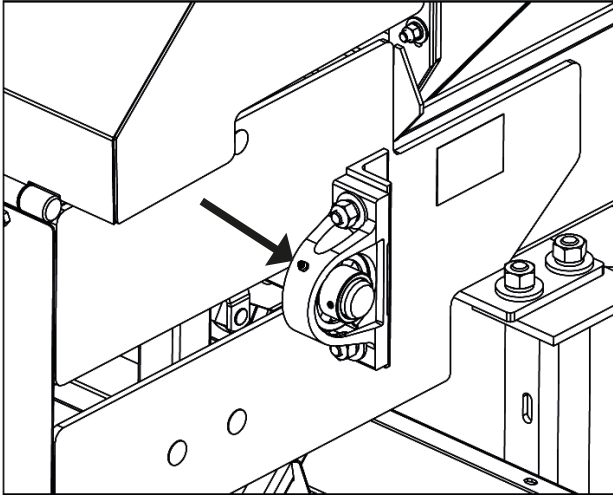

 **ATTENTION** | When lubricating the DCF-CO, do not exceed the amount of new grease. Put an adequate amount.

▪ Maintenance

- Lubrification every 24 hours of work

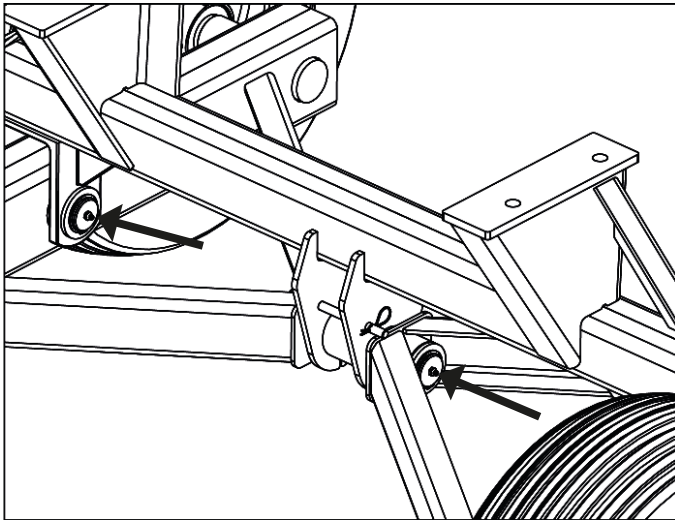
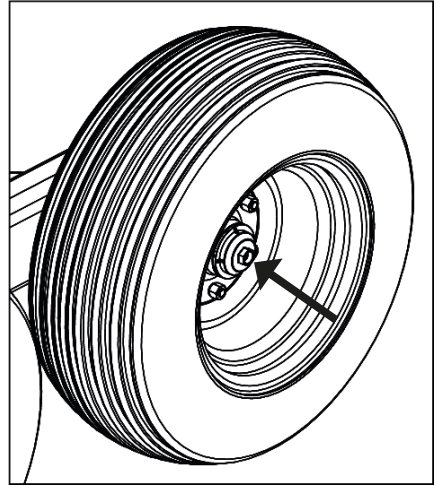
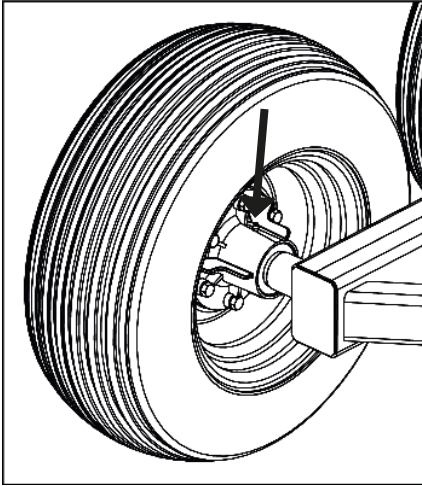
**ATTENTION**

When lubricating the DCF-CO, do not exceed the amount of new grease. Put an adequate amount.

▪ Maintenance

- Lubrification every 30 hours of work

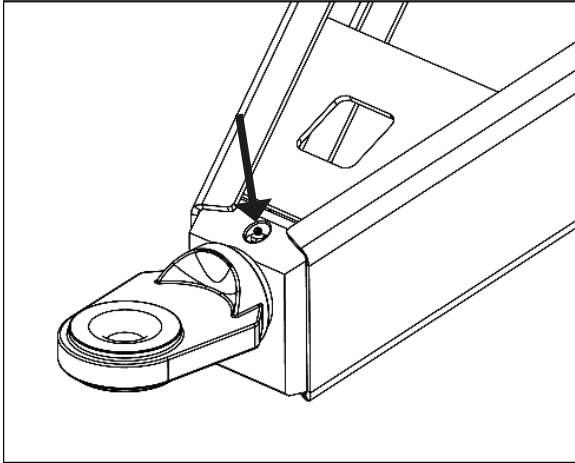

- Lubrification every 60 hours of work

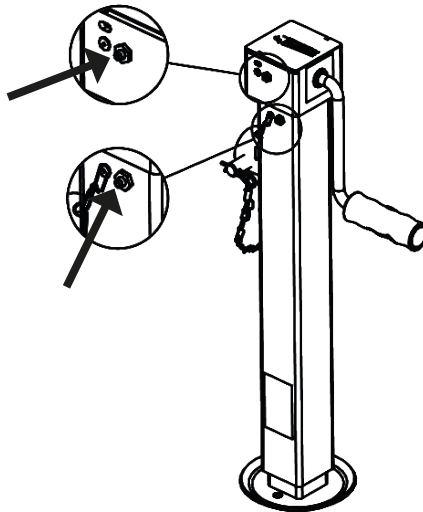

 **ATTENTION** | When lubricating the DCF-CO, do not exceed the amount of new grease. Put an adequate amount.

▪ Maintenance**ATTENTION**

Constantly check nuts and screws and, if necessary, retighten them. The maintenance of general re-installation of the equipment must be performed every 8 hours of work.

• Safety fuse

The reducer safety fuse (1) is intended to prevent damage to the transmission system caused by stresses greater than dimensioned. If the safety fuse (1) begins to break frequently, check:

- 01** - Check if there are no foreign objects locking the conveyor.
- 02** - If the product is not too compacted on the conveyor, which may occur with dry powder products.
- 03** - When adjusting the belt tensioner, one side may be tighter than the other.

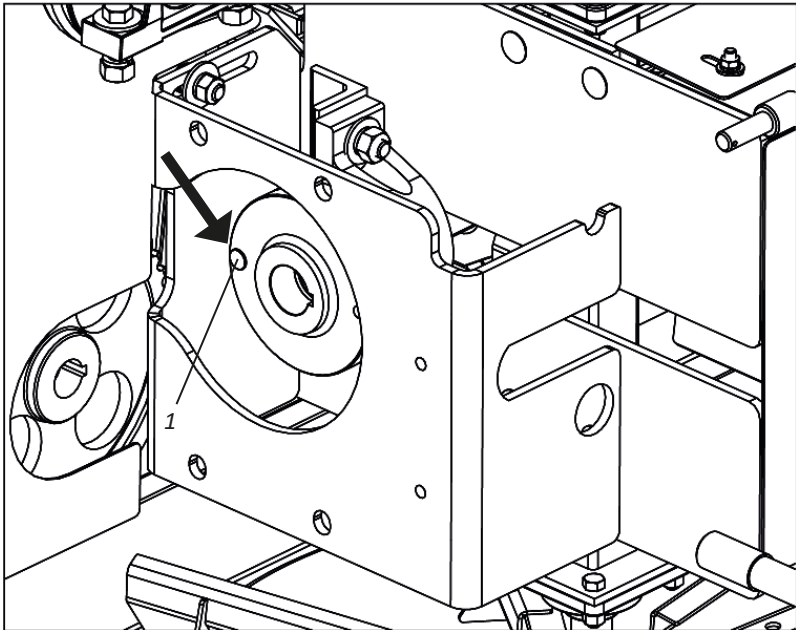
**ATTENTION**

Only use factory original fuses, since they are the only ones which have controlled hardness. Do not use two or more fuses, as this will increase resistance and damage the system.

▪ Maintenance

• Oil change - Gearbox

Periodically check oil level of gearbox (1) through the screw indicating the level (2) and refill it whenever required. To change the oil of the gearbox (1), proceed as follows:

- 01** - Remove drainage plug (4), breather cap (3) and level indicator screw (2) draining all oil from the gearbox (1).
- 02** - Then, reinstall the drainage plug (4) and fill with the breather cap (3) until oil leaks through the level vent (2).
- 03** - Finish by placing level indicator screw (2) and breather plug (3) back again.

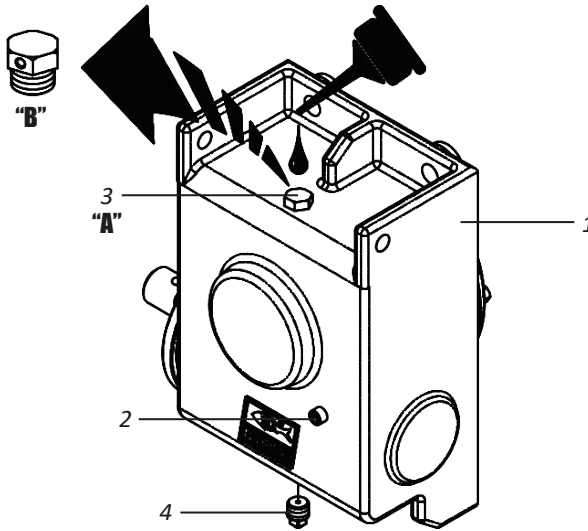

⚠ ATTENTION Do not fill with oil above the level. Only use the specified oil: 85W140 API GL-5 MIL-L-2105D SAEJ306; May/81.

❗ IMPORTANT Before operating the DCF-CO, remove the ("A") plug from the gearbox and place the ("B") breather plug in its place.

🔍 NOTE Replace oil in first 200 hours of operation. Then, change at every 1000 hours of operation. When using a specific oil brand, avoid completing the oil level with a different brand and specification.

▪ Maintenance**• DCF-CO (Cardan) reduction gearbox replacement - Part I****ATTENTION**

Before starting the reduction gearbox change, make sure that the tractor is turned off. **DO NOT** replace reduction gearbox if tractor is on. Ignoring this warning may cause serious injury or death.

To change the reduction gearbox, proceed as follows:

01 - Loosen the cotter pin (1), remove the pin (2) and uncouple the cardan (3) from the shaft (4).

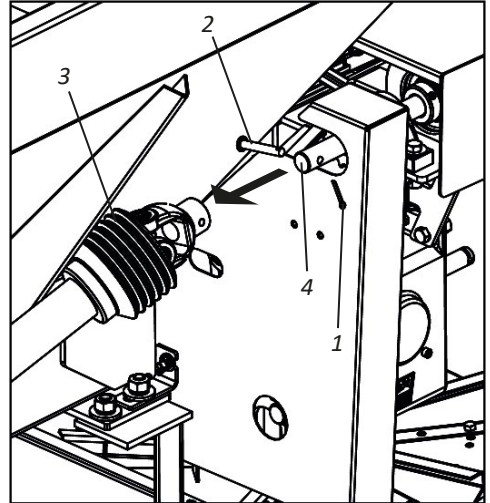

02 - Then, release the wing nuts (5), lock washers (6), flat washers (7), screws (8) and remove the protective cover (9) and the chain (10).

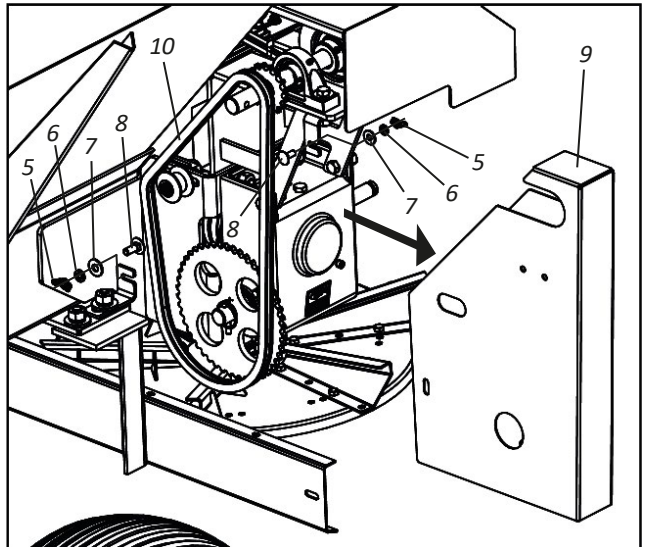

▪ Maintenance

• DCF-CO (Cardan) reduction gearbox replacement - Part II

03 - Then, loosen the handles (11), open the cover (12) and loosen the belt (13).

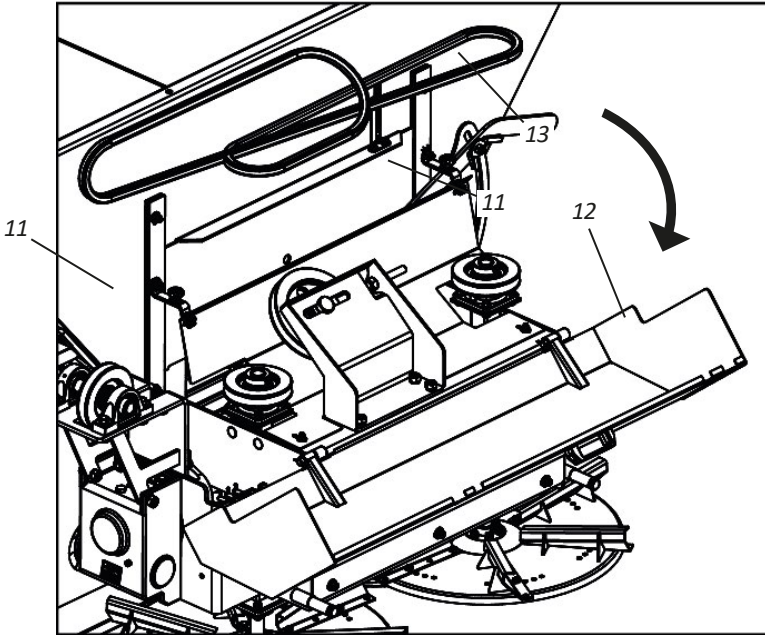

04 - Then, loosen the cotter pin (14) and remove the fuse pin (15) to loosen the flanges (16).

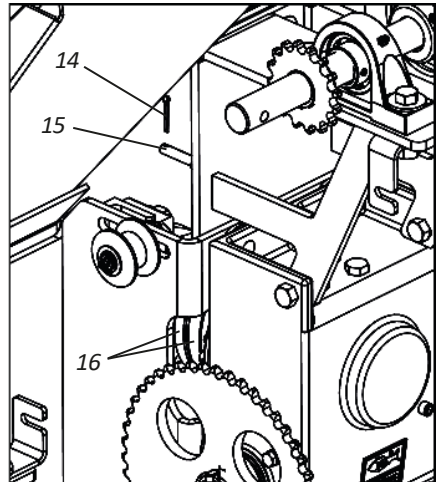

▪ **Maintenance**

• **DCF-CO (Cardan) reduction gearbox replacement - Part III**

- 05 - Then, loosen the screws (17), lock washers (18) and nuts (19).
- 06 - Then, loosen the screws (20), lock washers (21), nuts (22) and remove the bracket (23).
- 07 - Then, loosen the screws (24), lock washers (25), nuts (26) and remove the reduction gearbox (27).

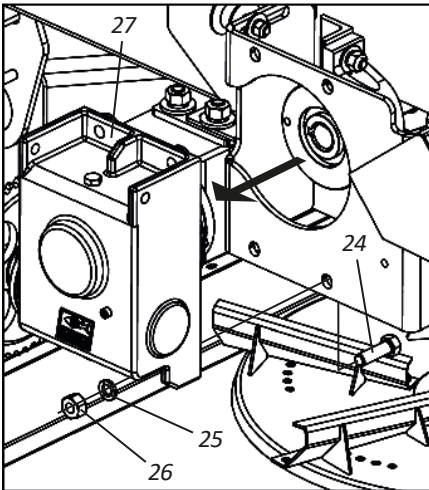
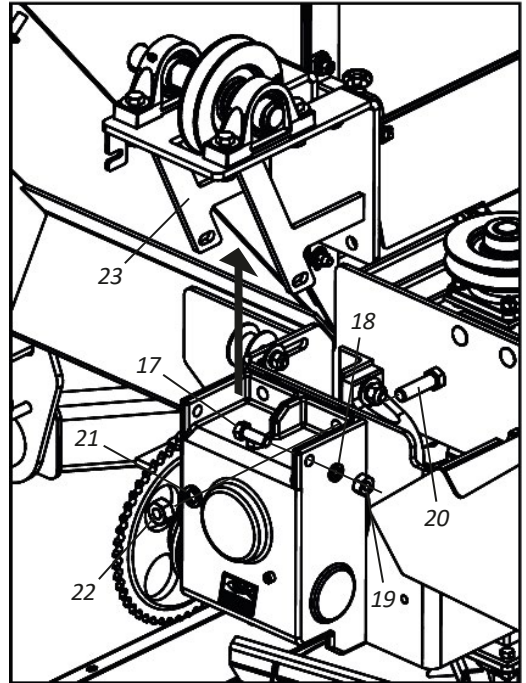

08 - Then, uncouple the flange (28) from the reduction gearbox (27).

09 - Then, couple the flange (28) to the new reduction gearbox (29), securing it through the linchpin (3).

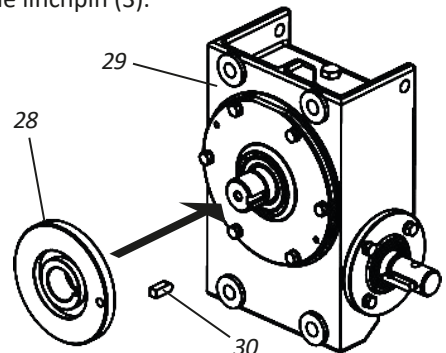
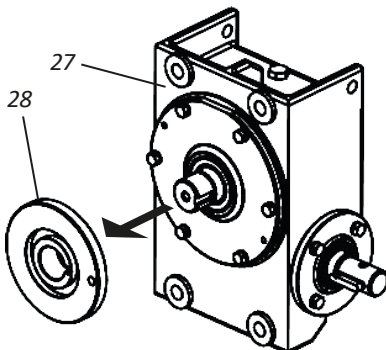

▪ Maintenance

• DCF-CO (Cardan) reduction gearbox replacement - Part IV

10 - Then, couple the new reduction gearbox (29) securing it through the screws (24), lock washers (25) and nuts (26).

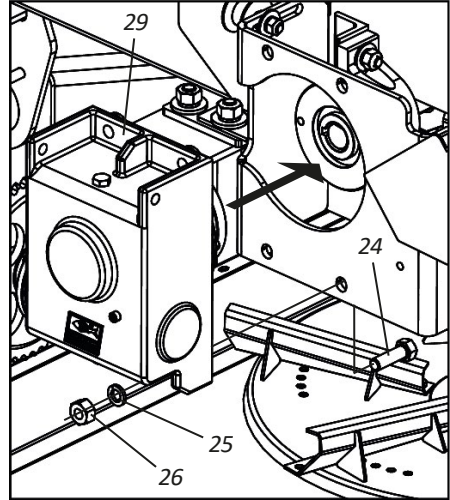

11 - Then, couple the bracket (23) securing it through the screws (20), lock washers (21), nuts (22) and screws (17), lock washers (18) and nuts (19).

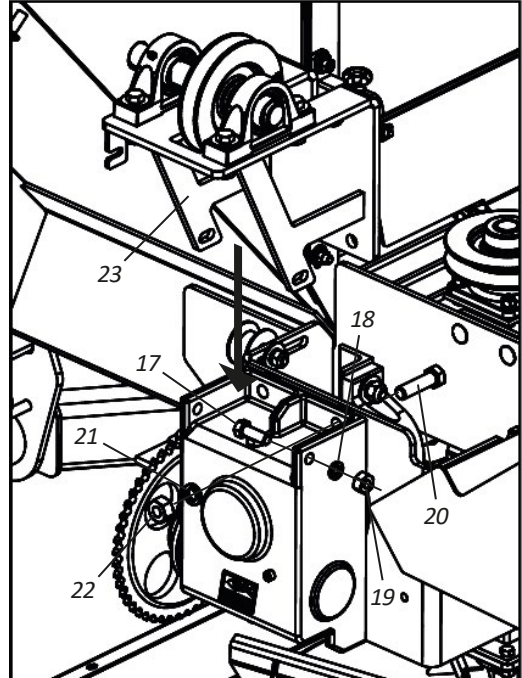

▪ Maintenance**• DCF-CO (Cardan) reduction gearbox replacement - Part V**

12 - Then, lock the flanges (16) through the fuse pin (15) and the cotter pin (14).

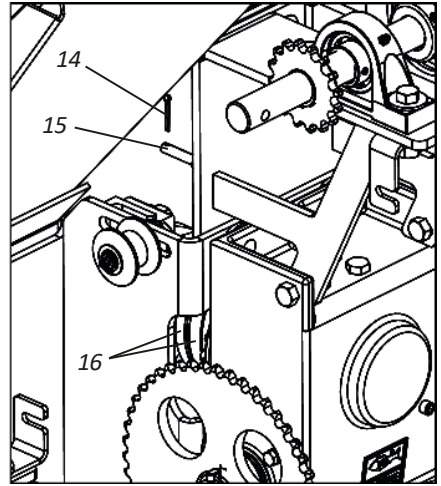

13 - Then, couple the belt (13), close the lid (12) and tighten the handles (11).

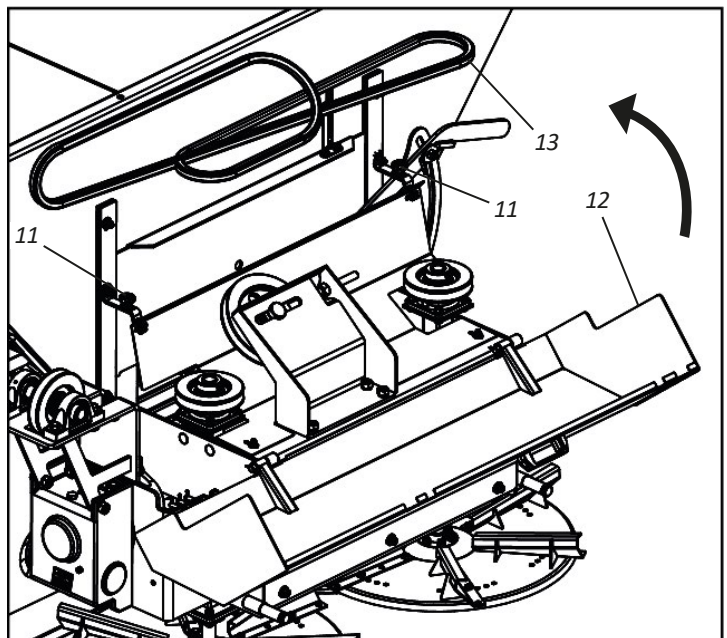

▪ Maintenance

• DCF-CO (Cardan) reduction gearbox replacement - Part VI

14 - Then, couple the chain (10) and couple the protective cover (9), securing it through the screws (8), flat washers (7), lock washers (6) and wing nuts (5).

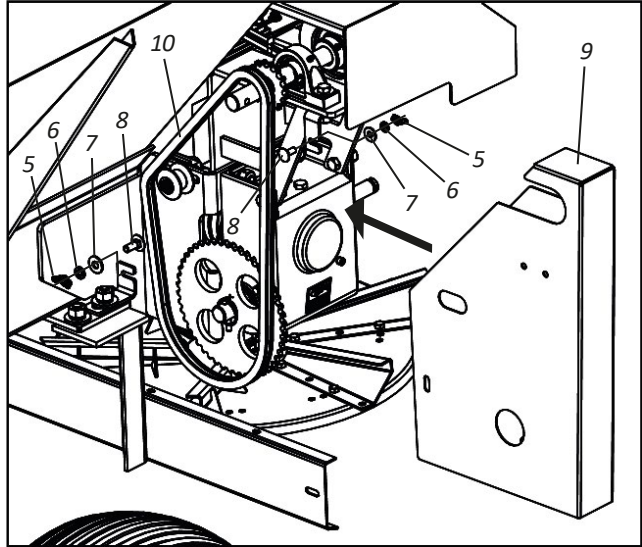

15 - Finish by coupling the cardan (3) to the shaft (4), securing it through the pin (2) and the pin (1).

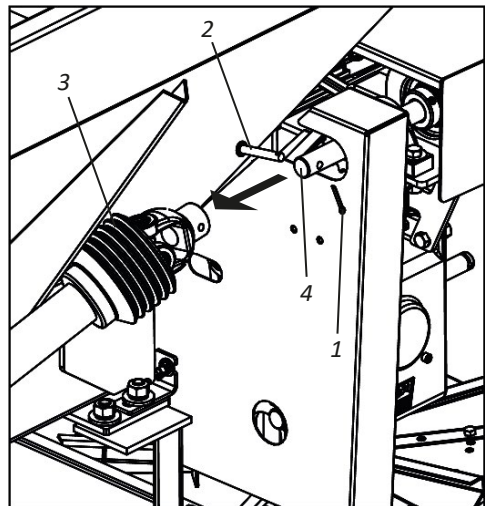

ATTENTION

Upon completing the assembly, before commencing work, perform a general overhaul and ensure that all components are correctly assembled.

▪ Maintenance**• DCF-CO (Hydraulic Motor) reduction gearbox replacement - Part I****ATTENTION**

Before starting the reduction gearbox change, make sure that the tractor is turned off. **DO NOT** replace reduction gearbox if tractor is on. Ignoring this warning may cause serious injury or death.

To change the reduction gearbox (1), proceed as follows:

- 01** - Loosen the screws (1), lock washers (2), flat washers (3), and remove the plate (4).
- 02** - Then, release the hydraulic hoses (5) through the nut (6), lock washer (7), plate (8) and screw (9).
- 03** - Then, release the nuts (10), lock washers (11), screws (12) and remove the hydraulic motor (13).
- 04** - Then, release the nut (14), lock washer (15), screw (16) and remove the bushing (17).

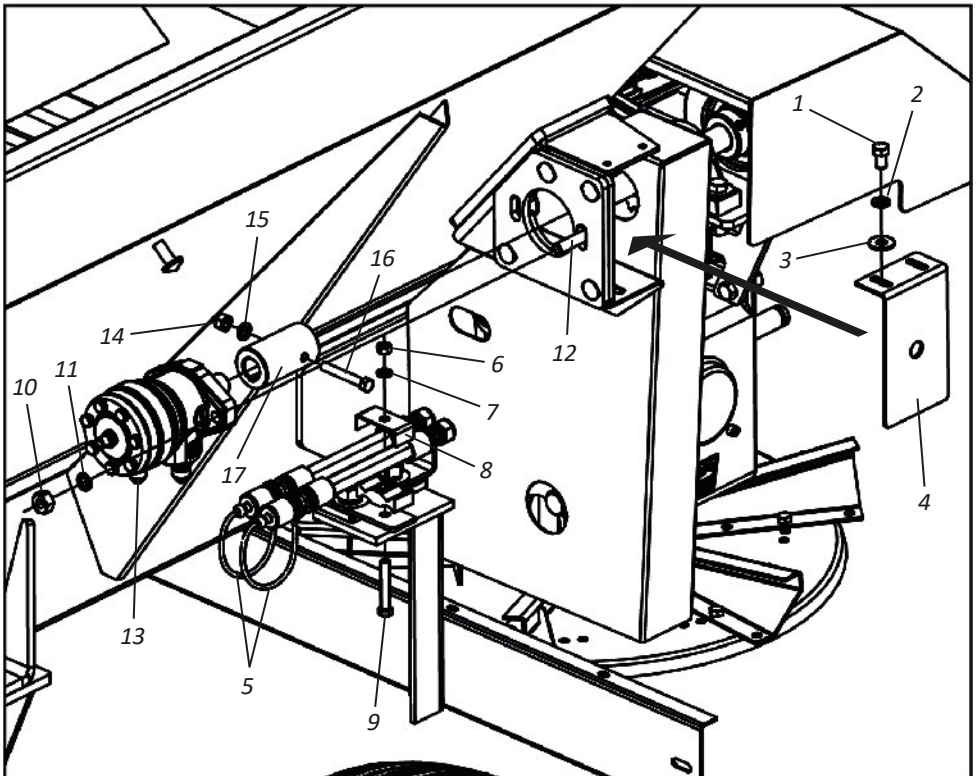

▪ Maintenance

• DCF-CO (Hydraulic Motor) reduction gearbox replacement - Part II

05 - Then, release the wing nuts (18), lock washers (19), flat washers (20), screws (21), remove the protective cover (22), and the chain (23).

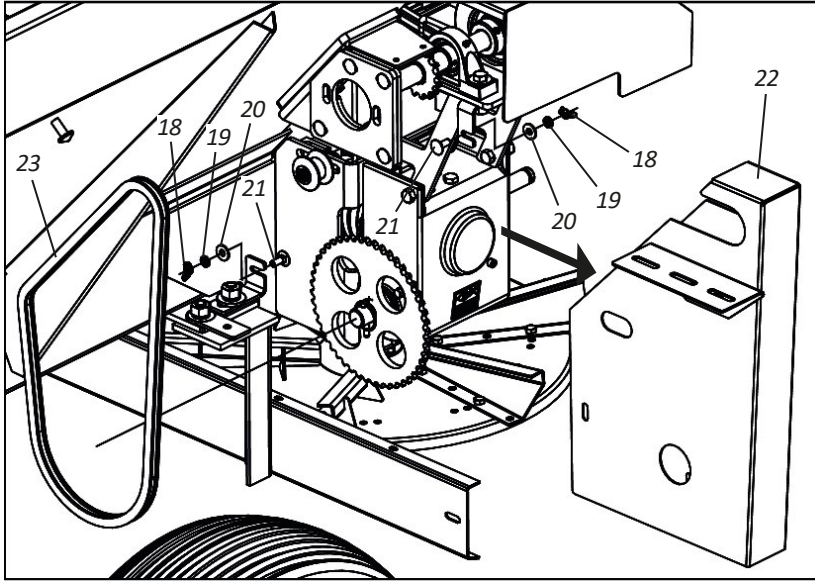

06 - Then, release the screws (24), lock washers (25), flat washers (26) and remove the retaining bracket (27).

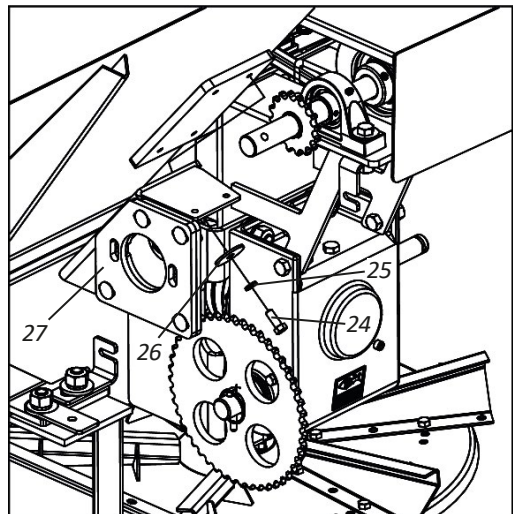

▪ Maintenance**• DCF-CO (Hydraulic Motor) reduction gearbox replacement - Part III**

07 - Then, loosen the handles (28), open the cover (29) and loosen the belt (30).

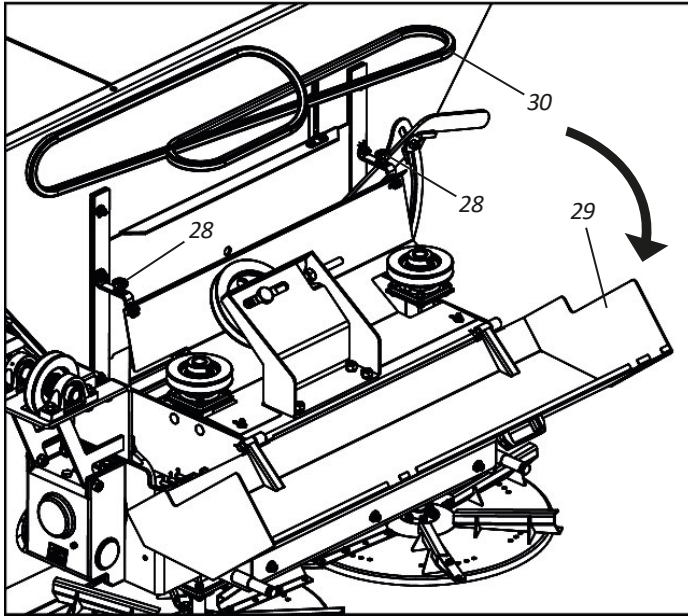

08 - Then, loosen the cotter pin (31) and remove the fuse pin (32) to loosen the flanges (33).

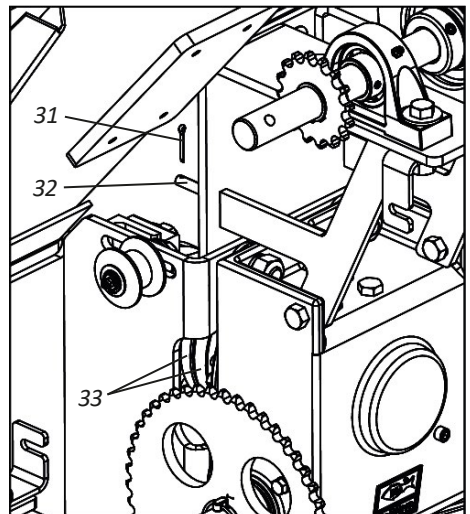

▪ Maintenance

• DCF-CO (Hydraulic Motor) reduction gearbox replacement - Part IV

09 - Then, loosen the screws (34), lock washers (35) and nuts (36).

10 - Then, loosen the screws (37), lock washers (38), nuts (39) and remove the bracket (40).

11 - Then, loosen the screws (41), lock washers (42), nuts (43), and remove the reduction gearbox (44).

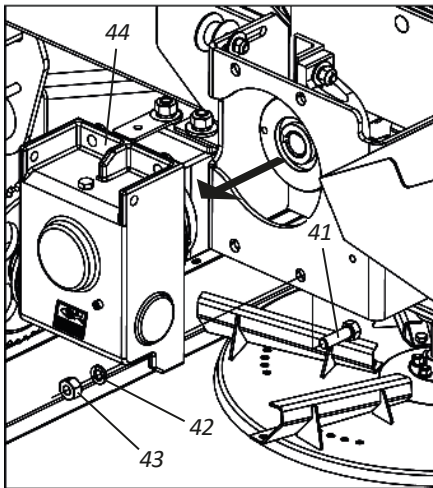
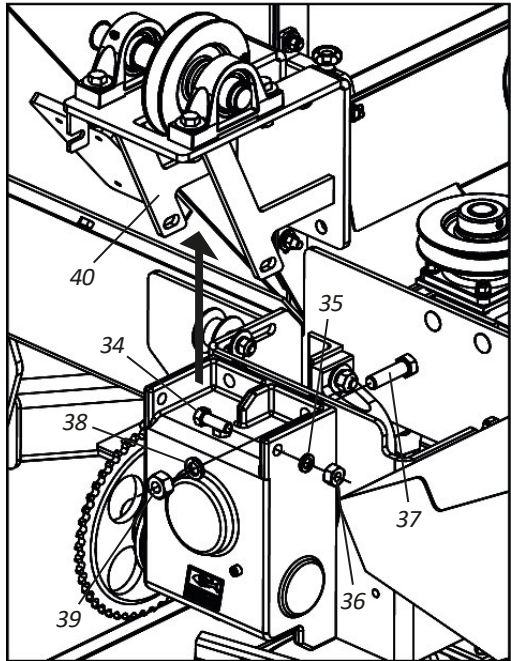

12 - Then, uncouple the flange (45) from the reduction gearbox (44).

13 - The, couple the flange (45) to the new reduction gearbox (46), securing it through the linchpin (47).

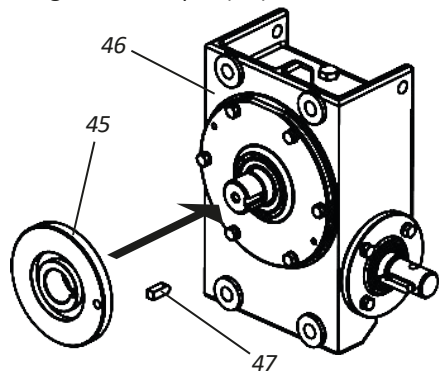
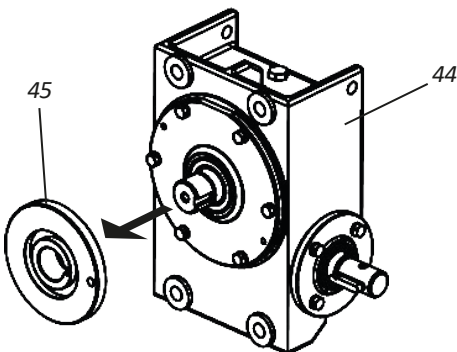

▪ Maintenance**• DCF-CO (Hydraulic Motor) reduction gearbox replacement - Part V**

14 - Then, couple the new reduction gearbox (46) securing it through the screws (41), lock washers (42) and nuts (43).

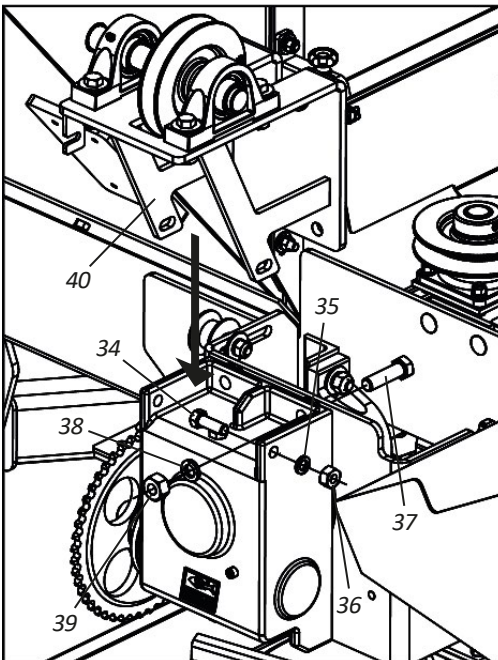
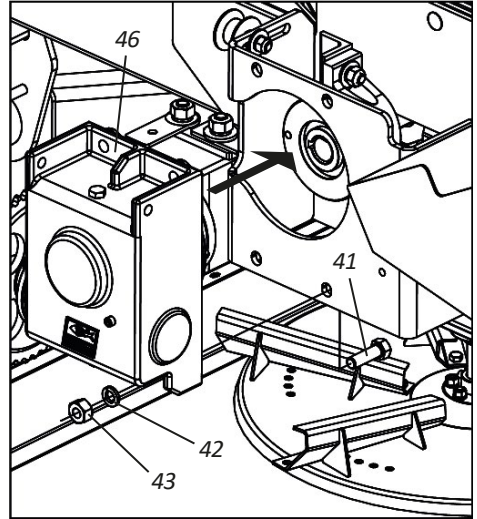

15 - Then, couple the bracket (40) securing it through the screws (37), lock washers (38), lock washers (35) and nuts (36).

▪ Maintenance

• DCF-CO (Hydraulic Motor) reduction gearbox replacement - Part VI

16 - Then, lock the flanges (33) through the fuse pin (32) and the cotter pin (31).

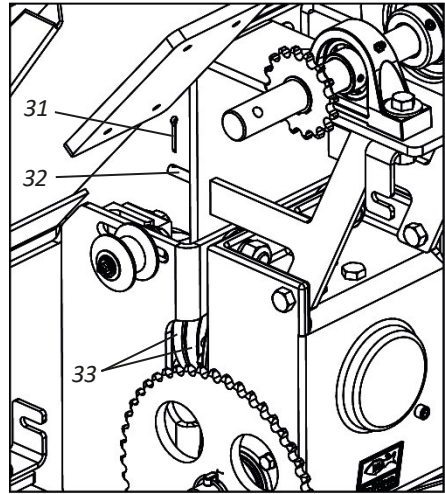

17 - Then, couple the belt (30), close the lid (29) and tighten the handles (28).

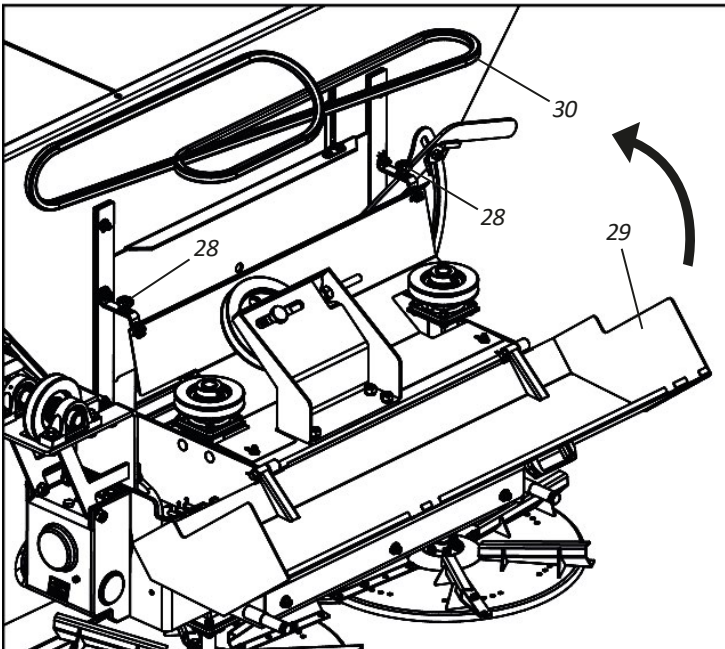

▪ Maintenance**• DCF-CO (Hydraulic Motor) reduction gearbox replacement - Part VII**

18 - Then, couple the mounting bracket (27), securing through the screws (24), lock washers (25), and flat washers (26).

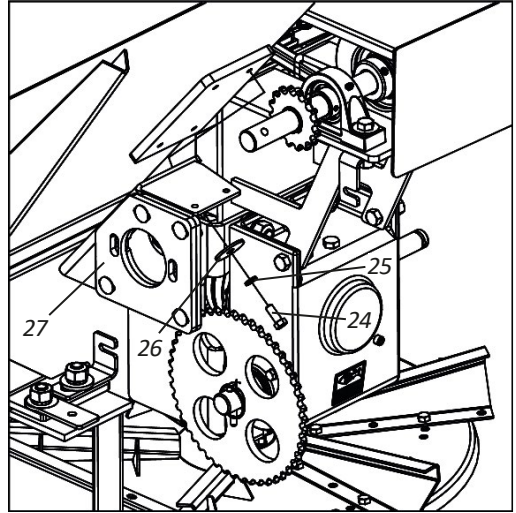

19 - The, couple the chain (23) and the protective cover (22), securing it through the screws (21), flat washers (20), lock washers (19), and wing nuts (18).

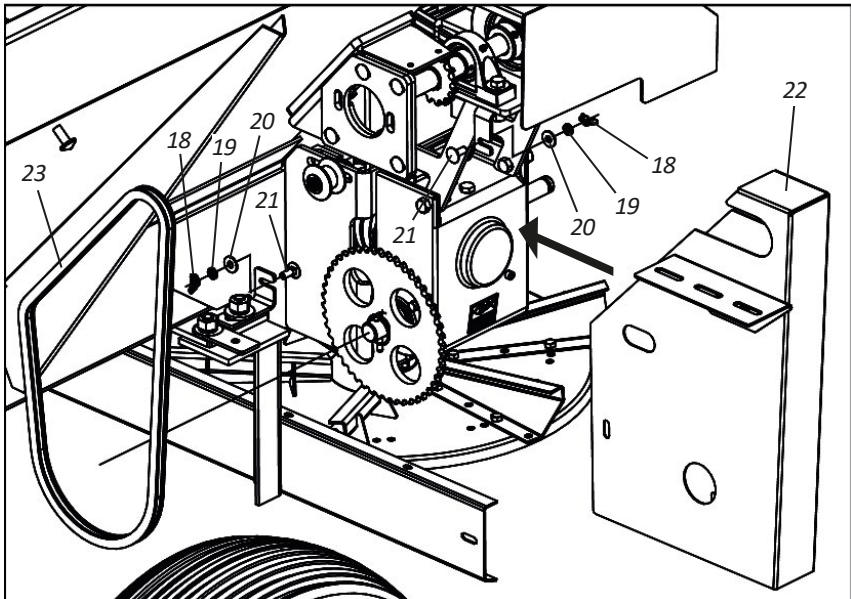

▪ Maintenance

• DCF-CO (Hydraulic Motor) reduction gearbox replacement - Part VIII

- 20** - Then, couple the bushing (17) securing through the screw (16), lock washer (15) and nut (14).
- 21** - Then, engage the hydraulic motor (13) securing it through the screws (12), lock washers (11), and nuts (10).
- 22** - Then, couple the hydraulic hoses (5) securing through the plate (8), screw (9), lock washer (7), and nut (10).
- 23** - Finish by coupling the plate (4), securing it through the screws (1), lock washers (2), flat washers (3).

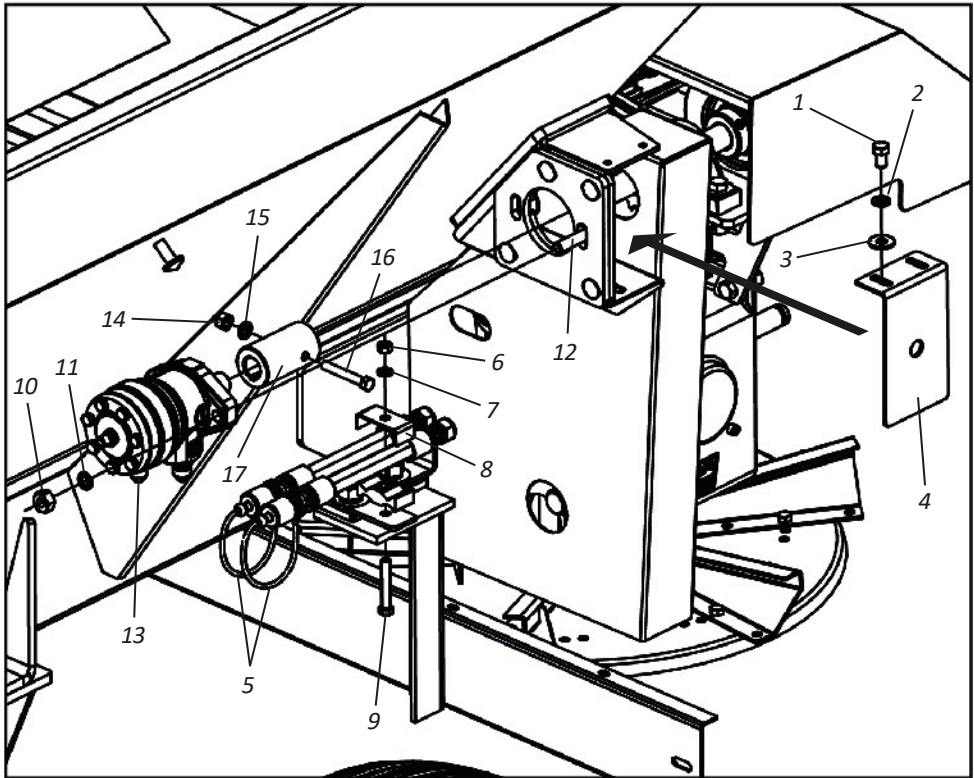

ATTENTION

Upon completing the assembly, before commencing work, perform a general overhaul and ensure that all components are correctly assembled.

▪ Maintenance
• Crown and pinion replacement (Reduction gearbox) - Part I

ATTENTION

Before starting to change the crown shaft and worm gear pinion, remove the reduction gearbox from the DCF-CO as instructed on pages 83 to 88 for DCF-CO (Cardan) and pages 89 to 96 for DCF-CO (Hydraulic Engine). Then, drain all reduction gearbox oil as instructed on page 82.

To change the crown shaft and worm drive pinion of the reduction gearbox, proceed as follows:

- 01** - Loosen the large cap (1) of the reduction gearbox (2) through the screws (3) and lock washers (4). **Note: Note that the retainer will be attached to the large lid (1) as show in detail "A".**

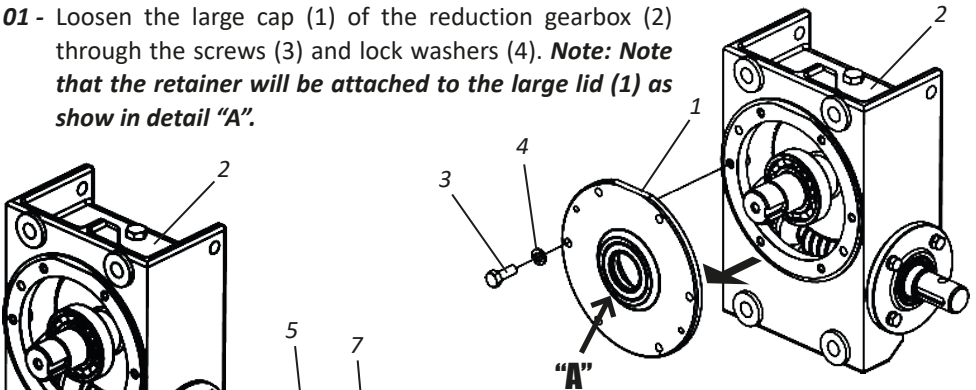

- 02** - Em seguida, solte a tampa menor (5) da caixa redutora (2) através dos parafusos (6) e arruelas de pressão (7). **Obs: Repare que o retentor estará fixado na tampa menor (5), conforme mostra o detalhe "B".**

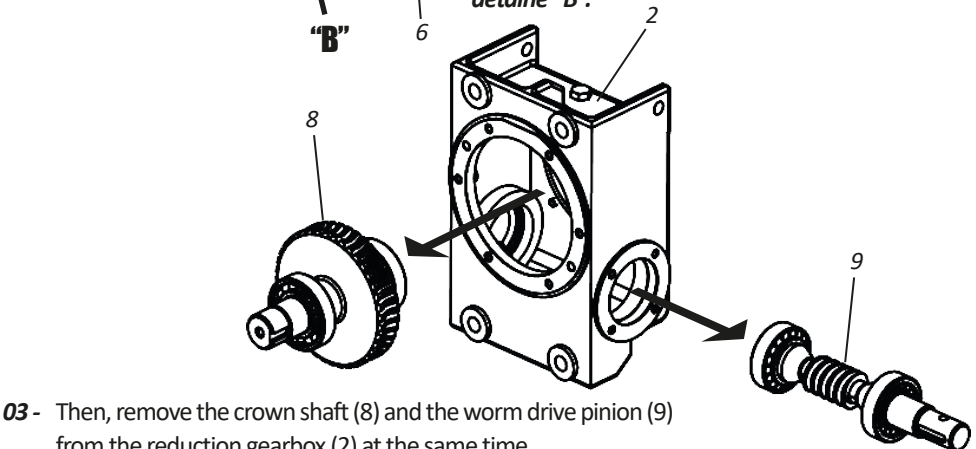

- 03** - Then, remove the crown shaft (8) and the worm drive pinion (9) from the reduction gearbox (2) at the same time.

▪ Maintenance

• Crown and pinion replacement (Reduction gearbox) - Part II

04 - Then, remove the old bearings (10) from the old crown shaft (8) and the worm gear pinion (9).

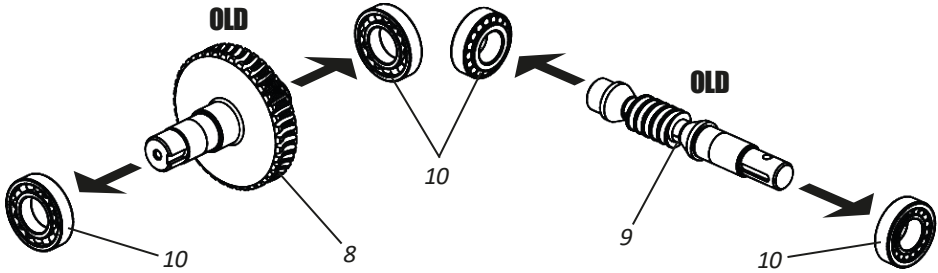

05 - Then, place the new bearings (10) on the new crown shaft (11) and worm gear pinion (12).

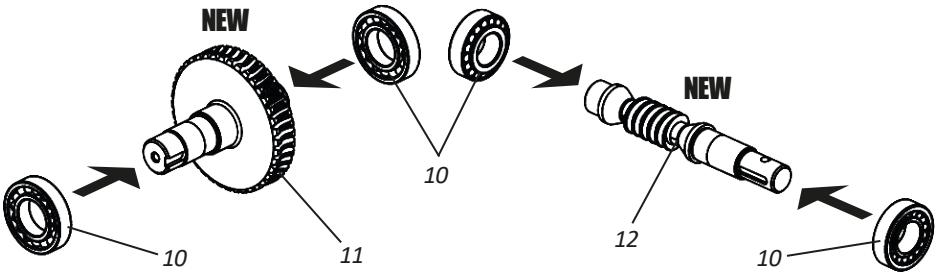

06 - Then, at the same time, replace the crown shaft (8) and the worm gear pinion (9) in the reduction gearbox (2), adjusting them.

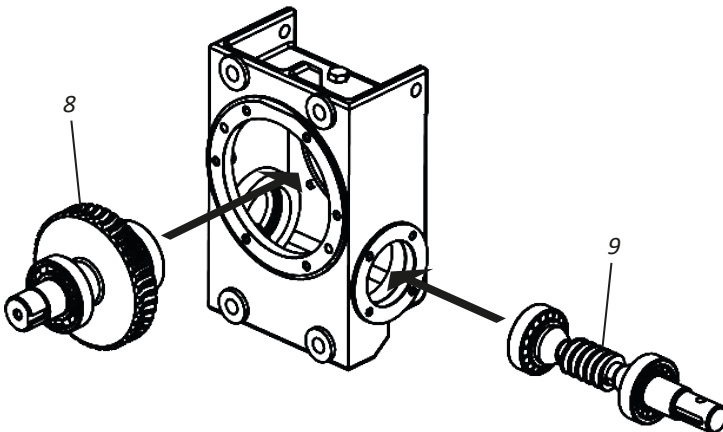

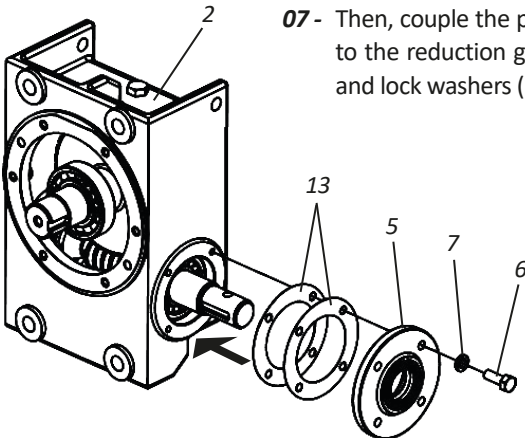
▪ Maintenance**• Crown and pinion replacement (Reduction gearbox) - Part III**

07 - Then, couple the paper gaskets (13) and the smaller cover (5) to the reduction gearbox (2) securing through the screws (6) and lock washers (7).

08 - Finish by coupling the paper gaskets (14) and the large lid (1) of the reduction gearbox (2), securing them through the screws (3) and lock washers (4).

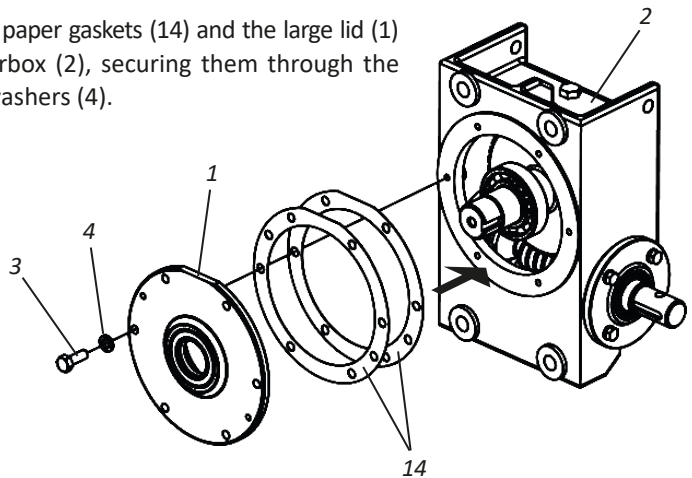
**! ATTENTION**

After changing the crown shaft and the pinion worm gear, fill the reduction gearbox with oil as instructed on page 82. Then, couple the reduction gearbox to the DCF-CO as instructed on pages 83 to 88 for DCF-CO (Cardan) and pages 89 to 96 for DCF-CO (Hydraulic Engine).

! IMPORTANT

When the reduction gearbox assembly (2) is finished if the smaller cover (5) and large cap (1) have gaps, replace the paper gaskets (13 and 14).

▪ Maintenance

• Operational Maintenance

PROBLEMS	PROBABLE CAUSES	SOLUTIONS
Product not flowing to the discs or insufficient amount.	The shut-off gate may be closed.	Check and take them out in it is the case.
	Foreign objects locking the conveyor.	Assemble the cardan correctly or replace crossheads with excessive wear.
	Conveyor, roller chain or broken fuse.	Retighten the bearings or replace them if damaged.
	Wrong assembly of the gears.	Tension the conveyor belt.
Distribution of the product in the soil is not uniform.	Distance between on stroke and the other is too long.	Reduce distance between strockes and operate according within the recommended distance.
	Fin in the wrong position on power distribution discs.	Check the position of the fins if they are not inverted according to the rotating direction of the distributor discs. If they are inverted, proceed with their correct assembly.
	Rotating the power outlet.	Correct rotation in the PTO which should be 540 RPM.
	Very strong wind.	Wait until the wind reduces or use the buffer (optional).
Distribution range too narrow.	Position of fins on power distribution discs.	Adjust the fins on the discs for a more open position.
Recommended dosage is not obtained.	Dosage system. Work speed above recommendation.	Increase gate flow. Reduce work speed.
Dosage higher than recommended.	Dosage system. Work speed under recomendation.	Reduce gate flow. Adjust work speed to the recommended one.
Rompimento do fusível com frequência.	Belt operating over recommended speed. Foreign objects locking the conveyor.	Reduce belt speed and increase gate flow. Check and clean the belt.

▪ Maintenance
• Operational Maintenance

PROBLEMS	PROBABLE CAUSES	SOLUTIONS
Vibration or excessive noises during operation.	Foreign objects inside the DCF-CO.	Check and take them out in it is the case.
	Wrong cardan assembly or worn out crosshead.	Assemble the cardan or replace crossheads with excessive wear.
	Loosen or damaged bearings.	Retighten the bearings or replace them if damaged.
	Conveyor adjustment	Tension the conveyor belt.
	PTO Rotation.	Keep rotation in 540 Rpm.
Frequent breaking of the use.	Belt operating over recommended speed. Foreign objects locking the conveyor.	Reduce belt speed and increase gate flow. Check and clean the belt.

▪ Maintenance

• Cares

- 01** - Before each work, check the condition of all pins and screws. Where necessary, retighten or replace them.
- 02** - Movement speed should be carefully controlled according to the terrain's conditions.
- 03** - The **DCF-CO** is used in several applications, requiring knowledge and attention in its handling.
- 04** - Only local conditions can determine the best way to operate the **DCF-CO**.
- 05** - When assembling or disassembling parts of the **DCF-CO**, use appropriate methods and tools.
- 06** - Carefully observe the lubrication intervals in the various lubrication points of the **DCF-CO**. Respect the lubrication intervals.
- 07** - Always check if the parts have wears. If there is a need for replacement, always demand Baldan original parts.

! IMPORTANT | Proper and periodic maintenance are necessary to ensure the long life of the **DCF-CO**.

• General cleaning

- 01** - When storing the **DCF-CO**, perform a general cleaning and wash it thoroughly with water only. Make sure the paint has not worn out, if this has happened, apply a general coat and protective oil and fully lubricate the **DCF-CO**. Do not use burned oil or other abrasive.
- 02** - After the work, proceed as follows:
 - Remove transmission chains and keep them immersed in oil until the next work.
- 03** - Completely lubricate the **DCF-CO**. Check all moving parts of the **DCF-CO**, for wear and tear or gaps, make the required adjustments or parts replacements, leaving the machine ready for the next work.
- 04** - When the **DCF-CO** is not in use, clean any product residues remaining after use, such as limestone, fertilizers, dirt, etc.
- 05** - Spray the entire **DCF-CO** with castor oil or preservative oil, never use burnt oil.
- 06** - Replace any damaged or missing stickers, especially warnings. Make everyone aware of the importance and risks of accidents when instructions are not followed.
- 07** - Clean the cardan every 15 days or sooner if necessary.

▪ Maintenance

• General cleaning

- 08** - Remove the protective caps, separate “male” from “female”, wash and remove crusts, dry and lubricate sliding parts with grease and reassemble.
- 09** - After all maintenance precautions, store your **DCF-CO** in a plain surface, at a covered and dry location, away from animals and children.
- 10** - We recommend washing the **DCF-CO** with water only on the beginning of works.



ATTENTION

Do not use abrasives or chemical products to wash the DCF-CO, as it may damage its painting and adhesives.

• Distributor Preservation - Part I

To extend the useful life and appearance of the **DCF-CO**, follow the instructions below:

- 01** - Wash and clean all distributor components during and at the end of the work season.
- 02** - Use neutral products to clean the distributor following the safety and handling guidelines provided by the manufacturer.
- 03** - Always carry out maintenance during the periods indicated in this manual.

• Distributor Preservation - Part II

The practices and care below make a difference for the conservation of the **DCF-CO** if adopted by the owner or operator.

- 01** - Be careful when performing high-pressure washing; do not direct the water jet to connectors and electrical components. Isolate all electrical components;
- 02** - Use only NEUTRAL detergent and water (pH equal to 7);
- 03** - Apply the product, strictly following the manufacturer’s instructions, on a wet surface and in the correct sequence, respecting the application and washing times;

▪ Maintenance

- 04** - Stains and dirt not removed with the products should be removed with the aid of a sponge.
- 05** - Rinse the machine with clean water to remove any chemical residues..
- 06** - Do not use:
 - Detergents with a basic active ingredient (pH less than 7), can damage/stain the paint on the distributor.
 - Detergents with acid active ingredients (lower than 7 pH), act as zinc stripper/ remover (parts protection against oxidation).

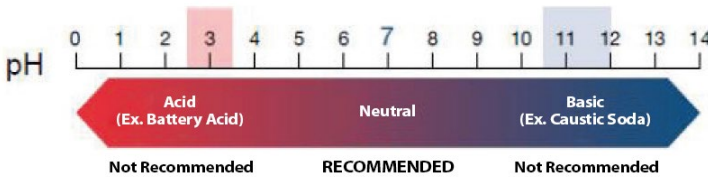

- 07** - Allow the machine to dry in the shade so that it does not accumulate water in its components. Very fast drying can cause stains on your paint.
- 08** - After drying, lubricate all chains and greases according to the recommendations in the operator's manual.
- 09** - Spray the whole machine, especially zinc parts, with protective oil, following the manufacturer's application instructions. The protective also prevents dirt from adhering to the machine, facilitating subsequent washings.
- 10** - Observe curing (absorption) time and application intervals as recommended by the manufacturer.

⚠ ATENTION | Do not use any other type oil to protect the distributor (used hydraulic oil, burnt oil, diesel, castor oil, kerosene, etc.).

❗ IMPORTANT | We recommend the following protective oils:

- Bardahl: Agro protective 200 or 300
- ITWChemical: Zoxol DW - Series 4000

🔍 NOTE | Ignoring the conservation measures mentioned above may result in loss of warranty for painted or zinc-coated components which may suffer oxidation (rust).

▪ Optional

• Optional Accessories - Part I

The DCF-CO has optional accessories that can be acquired according to the work needs.

HYDRAULIC ENGINE SYSTEM

The hydraulic engine system can be optionally purchased to transform your **DCF-CO** (Cardan) into a **DCF-CO** (Hydraulic Engine). Before purchasing the hydraulic engine system, observe the warning below and check that your tractor meets the requirements for hydraulic engine operation.

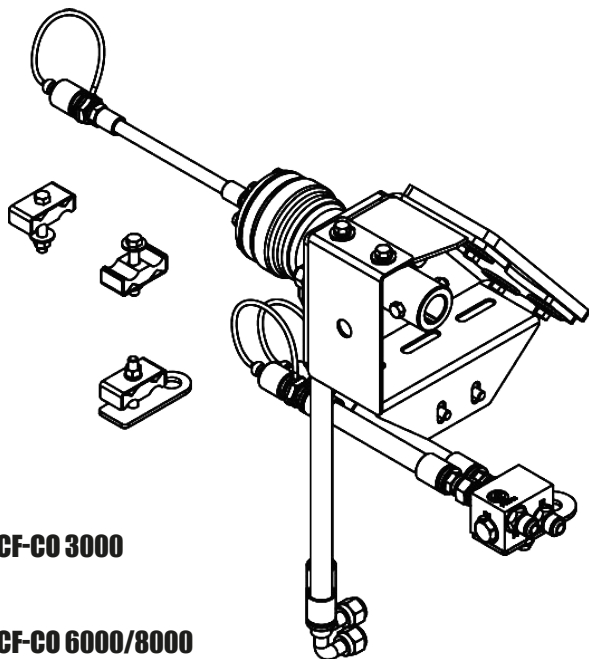

FULL HYDRAULIC ENGINE SYSTEM - DCF-CO 3000
CÓD: 5528011012-3

FULL HYDRAULIC ENGINE SYSTEM - DCF-CO 6000/8000
CÓD: 5528011010-7

! ATTENTION

For the operation of the hydraulic engine system and the DCF-CO with hydraulic engine, the tractor must have a continuous flow hydraulic system and a 40 to 50 L/Min hydraulic pump. If the tractor does not include these items, both the hydraulic engine system and the DCF-CO with a hydraulic engine will not work.

▪ Optional

- Optional accessories - Part II

DRIVING GEARBOX

The driver box is used for jobs where the application of the fertilizer should be directed in line, for example under canopies.

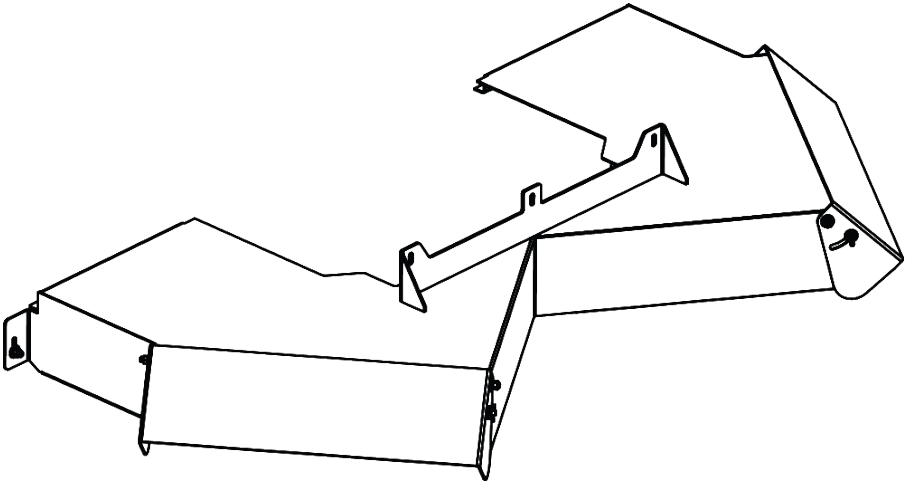

TIRES

For work on clay soils, the **DCF-CO 3000** and **6000** can be optionally purchased with 11L-15 tires.

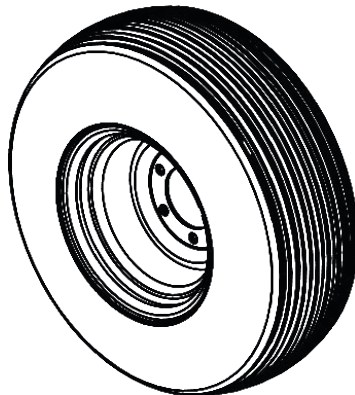

▪ Optional

- **Optional accessories - Part III**

BAFFLE WITH CANVAS

The baffle with canvas is used for the distribution of powdered products mainly when there are occurrences of winds. Using the baffle, ensures greater distribution uniformity, retaining the product.

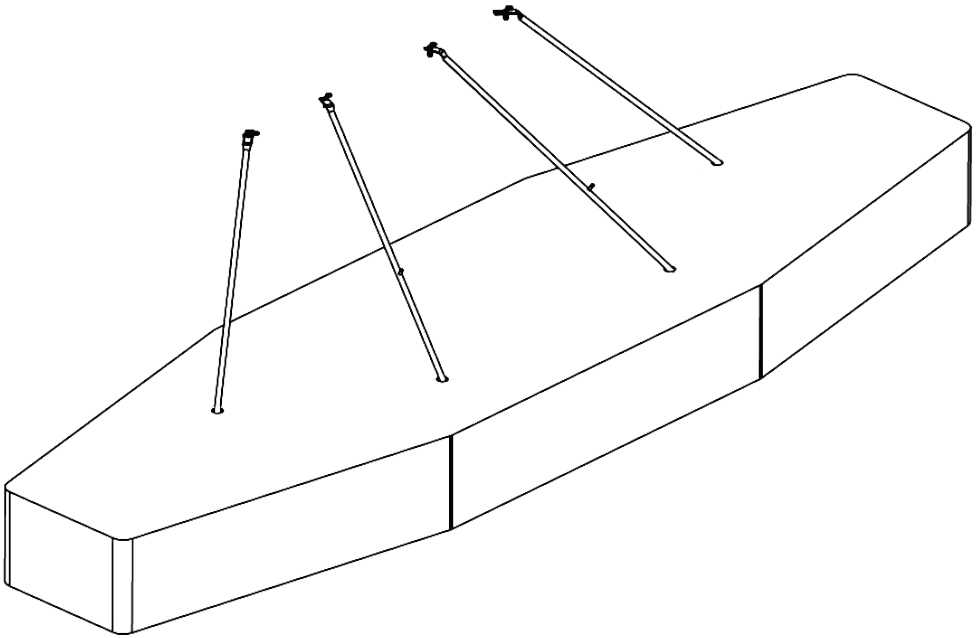

▪ Optional

- Optional accessories - Part IV

BAFFLE WITH RUBBER

The baffle with rubber is used for the distribution of powdered products mainly when there are occurrences of winds. Using the baffle ensures greater distribution uniformity retaining the product.

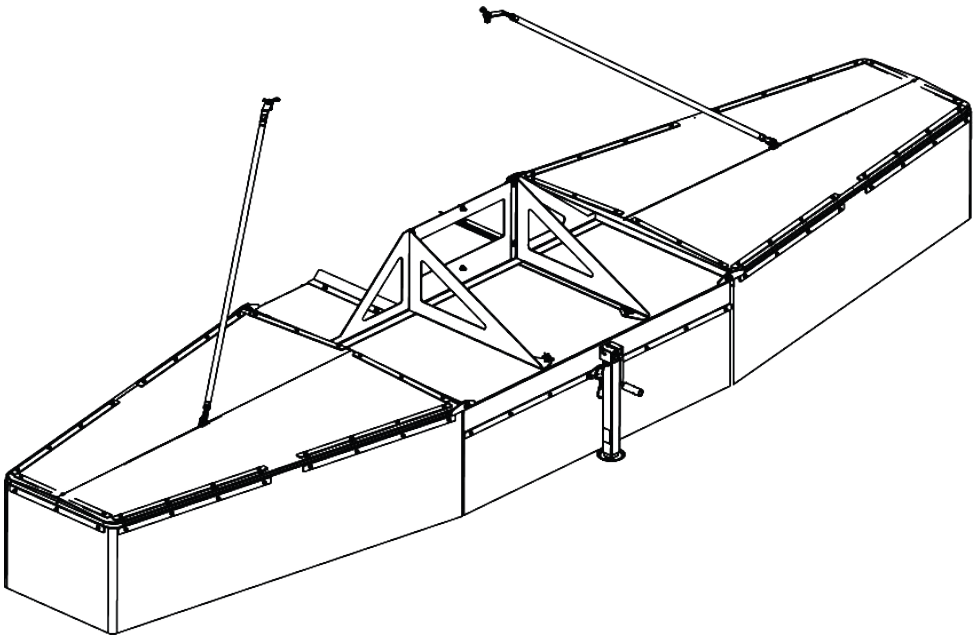

▪ Identification

• Identification plate

In order to consult the parts catalog or ask Baldan for service, always indicate the model (1), serial number (2) and manufacturing date (3), which is on the nameplate of your **DCF-CO**.



ATTENTION

The drawings in this Instruction Manual are merely illustrative.

CONTACT

In case of doubts, never operate or handle your equipment without referring to Post-Sales.
Telephone: 0800-152577
e-mail: posvenda@baldan.com.br

PUBLICATIONS

Code: 60550105287 | CPT: DCFCO12819A



▪ Identification

• Product Identification

Please make the correct identification of the data below, to always have information about the service life of your equipment.

Owner: _____

Dealer: _____

Property: _____

City: _____

State: _____

Certificate of Warranty no.: _____

Implement: _____

Serial No: _____

Purchase Date: _____

Invoice: _____

BALDAN IMPLEMENTOS AGRÍCOLAS S/A ensures the dealer normal performance of the implement for a period of six (6) months as of the delivery date on the retail invoice to the first final consumer. During this period, **BALDAN** undertakes to repair defects in material and/or of manufacture of its liability, including labor, freight and other expenses of the dealer's liability.

In the warranty period, request and replacement of eventual defective parts shall be made to the dealer of the area, who will submit the faulty piece for **BALDAN** analysis. When this procedure is not possible and the resolving capacity of the dealer is exhausted, the dealer will request the support of **BALDAN Technical Assistance** through a specific form distributed to dealers. After analyzing the replaced items by Baldan Technical Assistance, and concluding that it is not a warranty, then the dealer will be responsible for the costs related to the replacement; as well as material expenses, travel including accommodation and meals, accessories, lubricant used and other expenses arising from the call out to Technical Assistance, and Baldan company is authorized to carry the respective invoice in the name of the resale. Any repair carried in the product within the dealer warranty deadline will only be authorized by **BALDAN** upon previous budget presentation describing parts and work to be performed.

The product is excluded from this term if it is repaired or modified by representatives not belonging to the **BALDAN** dealer network, as well as the application of non-genuine parts or components to the user's product. This warranty is void where it is found that the defect or damage is caused by improper use of the product, failure to follow instructions or inexperience of the operator.

It is agreed that this warranty does not cover tires, polyethylene tanks, cardan, hydraulic components, etc., which are equipment guaranteed by their manufacturers. Manufacturing and/or material defects, object of this warranty term, will not constitute, under any circumstances, grounds for termination of a purchase agreement, or for indemnification of any nature.

BALDAN reserves the right to change and/or perfect the technical characteristics of its products, without previous notice, and without obligation to proceed in the same way with the products previously manufactured.

▪ Inspection and Delivery Certificate

SERVICE BEFORE DELIVERY: This implement was carefully prepared by the sale organization, with all its parts inspected according to the manufacturing prescriptions.

DELIVERY SERVICE: The user was informed about the current warranty terms and instructed on the usage maintenance precautions.

I confirm that the user has been informed about the current warranty terms and instructed on the usage maintenance precautions.

Implement: _____ Serial Number: _____

Date: _____ Tax Number: _____

Dealer: _____

Telephone: _____ CEP: _____

City: _____ State: _____

Owner: _____

Telephone: _____

Address: _____ Number: _____

City: _____ State: _____

E-mail: _____

Sale date: _____

Signature / Dealer Stamp _____

▪ Inspection and Delivery Certificate

SERVICE BEFORE DELIVERY: This implement was carefully prepared by the sale organization, with all its parts inspected according to the manufacturing prescriptions.

DELIVERY SERVICE: The user was informed about the current warranty terms and instructed on the usage maintenance precautions.

I confirm that the user has been informed about the current warranty terms and instructed on the usage maintenance precautions.

Implement: _____ Serial Number: _____

Date: _____ Tax Number: _____

Dealer: _____

Telephone: _____ CEP: _____

City: _____ State: _____

Owner: _____

Telephone: _____

Address: _____ Number: _____

City: _____ State: _____

E-mail: _____

Sale date: _____

Signature / Dealer Stamp _____

▪ Inspection and Delivery Certificate

SERVICE BEFORE DELIVERY: This implement was carefully prepared by the sale organization, with all its parts inspected according to the manufacturing prescriptions.

DELIVERY SERVICE: The user was informed about the current warranty terms and instructed on the usage maintenance precautions.

I confirm that the user has been informed about the current warranty terms and instructed on the usage maintenance precautions.

Implement: _____ Serial Number: _____

Date: _____ Tax Number: _____

Dealer: _____

Telephone: _____ CEP: _____

City: _____ State: _____

Owner: _____

Telephone: _____

Address: _____ Number: _____

City: _____ State: _____

E-mail: _____

Sale date: _____

Signature / Dealer Stamp _____

3rd copy - Manufacturer (Please send completed within 15 days).

1.74.05.0059-5

AC MATÃO
ECT/DR/SP

RESPONSE CARD

NO STAMPING IS REQUIRED

THE STAMP WILL BE PAID BY:



BALDAN IMPLEMENTOS AGRÍCOLAS S/A.

Av. Baldan, 1500 | Nova Matão | CEP: 15993-900 | Matão-SP | Brasil

Tel: (16) 3221-6500 | Fax: (16) 3382-6500

www.baldan.com.br | email: sac@baldan.com.br

Export: Tel: +55 (16) 3221-6500 | Fax: +55 (16) 3382-4212 | 3382-2480

email: export@baldan.com.br



Avenida Baldan, 1500
Nova Matão
15.993-900
Matão/SP - Brasil
sac@baldan.com.br
export@baldan.com.br

+55 16 3221 6500
baldan.com.br