

Instruction

Manual



GRI / GRPI

Drag Type Offset Disc Harrow - without tires / with tires

 **BALDAN**

INTRODUCTION

We thank you for the preference and congratulate your excellent choice in acquiring and implementing outstanding quality, manufactured in accordance with the advanced technology of **BALDAN IMPLEMENTOS AGRICOLAS S/A**.

This manual will assist you, in the necessary proceeds, since when you bought until the operational proceeds application, security and maintenance.

The **BALDAN** guarantees that deliver this implement to the dealer, working properly, and in perfect conditions.

The dealers it's under the responsibility to keep the protection and conservation while keep the implement in your stock, and then, to assembly, tighten, lubrication and overhaul.

On time of the technical deliver, the dealer must to have conducted the use customer about the maintenance, safety, and your obligations in a possible technical assistance, the obligation to see the warranty terms and read the instruction manual.

Any solicitation of warranty, please contact our Baldan technical service, by your Baldan dealer that you bought our implement.

Reaffirm the necessity to read carefully of warranty certificate and note all of items from this manual, therefore you will increase the working life your equipment.



Instruction Manual



GRI / GRPI

Drag type Offset Disc Harrow - without tires / with tires

BALDAN IMPLEMENTOS AGRÍCOLAS S/A.
CNPJ: 52.311.347/0009-06
Insc. Est.: 441.016.953.110



Scan the QR Code on the
identification plate of your
device and access this
Instruction Manual online.

 **BALDAN**

ÍNDICE

01 - Safety Rules	06 to 10
02 - Components :	
- Drag Type Offset Disc Harrow - GRI / GRPI	11
03 - Assembly:	
- Assembling discs section	12 to 13
- Join of front and rear frames	14
- Assembly of regulation opening set of disc harrow with 12, 14 and 16 discs	14
- Assembly or regulation opening set of disc harrow with 18, 20, 24 and 28 discs	15
- Head of hitch assembly	16
- Hitch of stabilizer bar	17
- Wheel hitch	17
- Scraper assembly	18
04 - Hitch harrow	18
05 - Adjustment and operations:	
- Adjustment opening	19
- Lateral displacement of harrow	20
- Adjustment of cross on front frame	20
- Transport (harrows with tires)	21
- Operations	22 to 23
06 - Tires pressure	24
07 - Lubrification	25
08 - Lubrification points	25 to 26
09 - Bearings adjustments	27
10 - Cleaning	27
11 - Spare parts	28
12 - Approx. production of GRI / GRPI harrows	28 to 29
13 - Technical Specification	30
14 - Identification	31

01 - SAFETY RULES



THIS ALERT SYMBOL INDICATES IMPORTANT SAFETY NOTES. WHENEVER YOU FIND IT IN THIS MANUAL, READ THE MESSAGE WITH ATTENTION TO AVOID ANY ACCIDENT.



ATTENTION

- Read this instruction manual carefully to know the recommended safety rules.

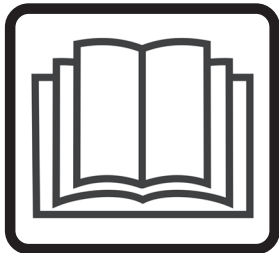

ATTENTION

- Only start the tractor operations, when are you properly accommodated and with the seat belt fasted.



ATTENTION

- Never carry people over the tractor or equipment.



! ATTENTION

- There are risks of serious injury by tipping when working on slopes.
- Never use excessive speed.

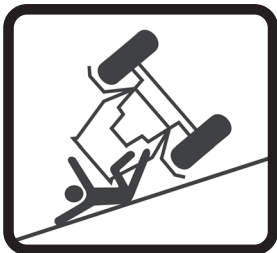

! ATTENTION

- Before any equipment maintenance, make sure that is properly stopped.
- Avoid getting hit.

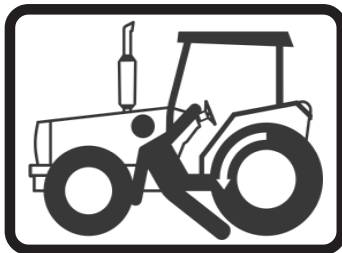

! ATTENTION

- Do not work with the tractor if the front there isn't enough weight to the rear equipment.
- If there is tendency to lift, add weight at the front tractor or front wheels.



ALCOHOL AND DRUGS MAY GENERATE LOSS OF REFLEX AND CHANGING OF OPERATOR FISICAL CONDITIONS. SO DO NOT WORK WITH THIS EQUIPMENT, IN USE OF THIS SUBSTANCE.



ATTENTION

- Keep yourself away from the active elements of the machine (Discs), they are sharp and can cause accidents.
- To do any service on the discs use safety gloves.









ATTENTION









- The hydraulic oil works under a pressure and can cause serious injuries, if has any leaks. Periodically check the state of hoses. If there is evidence of leaks immediately replace.
- Before connecting or disconnecting hydraulic hoses relieve the pressure of the system, set the command with the tractor off.



WARNING:

The incorrect handling of this equipment can result in serious or fatal accidents. Before using the implement, read carefully the instructions of this manual. Be sure that the person responsible for the operation is instructed about the correct handling, safety and if read and understood the instructions manual concerning this machine.

- 1 -  When operating the equipment make sure that nobody remains closer, inside or over the same.
- 2 -  When proceed may assembly or disassembly of discs, use gloves
- 3 -  When connect or unconnect the hydraulic hoses, release the circuit pressure.
- 4 -  Check periodically the rubbers conservation. If there is an indicium of oil emptying change it immediately because the oil works under high pressure and may cause serious damages.
- 5 -  Do not use baggy clothes that can twist to the machine.
- 6 -  Before you start the tractor engine, be firmly seated and sure you know thr operation of both, tractor and implement. Make sure the gear lever is in the neutral position, the P.T.O. drive is disengaged, and that the hydraulic lever command is also in the neutral position.
- 7 -  Do not start the tractor engine indoors without adequate ventilation, the exhaust gases are harmful to health.

- 8 -  While maneuver the tractor to clamp the implement be sure if there is space enough and nobody is too much close, maneuver always in slow gear and be ready to brake in case of emergency.
- 9 -  Do not adjust the implement working.
- 10 -  Working in inclined soil try to keep the necessary stability. In case of instability reduce the acceleration, turn the wheels to the inclined side of the soil and never lift the implement .
- 11 -  Conduct the tractor always in safety speeds, specially working in irregular or inclined soil, keep the tractor always geared.
- 12 -  Do not drive by roads, mainly during night times. Use warnings signs.
- 13 -  Do not work with the front of the tractor light. If there is trend to lift up add more weight in front or at the front wheels.
- 14 -  Getting out the tractor place the gearshift at the neutral position and apply the park brake.
- 15 -  Alcohol and drus may generate loss of reflex and changing of operator fisical conditions. So do not work with this equipment in use of this substance.
- 16 -  Read and explain all the proceeds above to the user that can not read..

DRAG TYPE OFFSET DISC HARROW - GRI
DRAG TYPE OFFSET DISC HARROW - GRPI (WITH TIRES)

02 - COMPONENTS

- 1 - Front frame
- 2 - Rear frame
- 3 - Regulation lock
- 4 - Handle lock
- 5 - Rear stabilizer bar
- 6 - Front stabilizer bar
- 7 - Disc axle
- 8 - Discs
- 9 - Axle join frame
- 10 - Transversal bar
- 11 - Header couplig
- 12 - Jumel coupling
- 13 - Wheel



FIGURA 01

03 - ASSEMBLY

ASSEMBLING DISCS SECTION

- 1 - Check the parts list that is inside the package box.
- 2 - Before starting the assembly, place protective gloves.
- 3 - The assembly must always start with the disc section.
- 4 - Place on axis item 1, **Figure 02** washer concave item 2, item 3 a nut, the lock item 4, and secure with the nut section 5 as shown in **Figure 02**. Note that the nut be faceando with the tip of the shaft.
- 5 - Place on shaft item 1, one disc item 6, one bearing* item 7 another disc, the spool item 8 and so on as shown in **Figure 02**.
- 6 - When the set is complete with all discs, bearings and spools, place the convex washer item 9, the other nut item 3, with a key grip with the whole set until firm.
- 7 - Then, putting all the discs and tighten the nut item 3, by impacts. When it is about getting the maximum tighten, adjust the lock item 4 with covex washer, always tightening the nut to match the holes, fix them through the nut item 5.

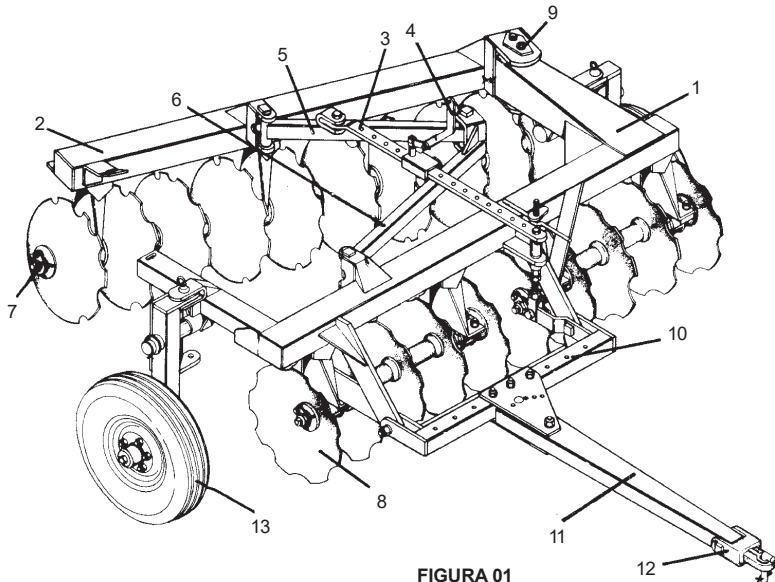
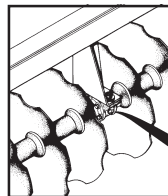

FIGURE 03

View of the front and rear section assembly with the lubrication system to the back of the implement to give greater protection to it.

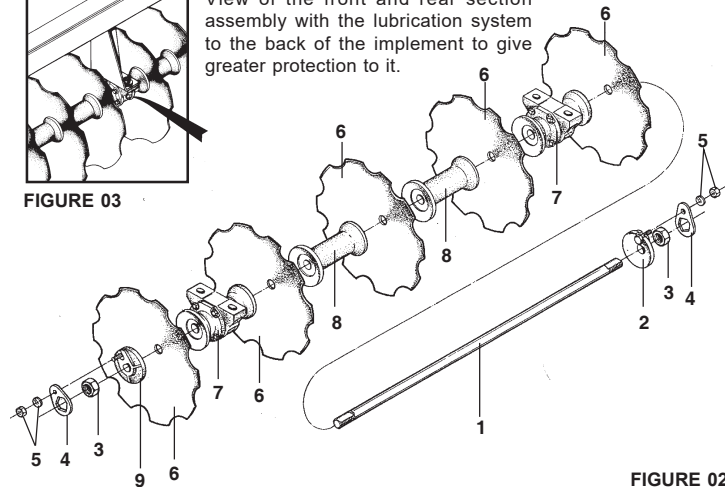
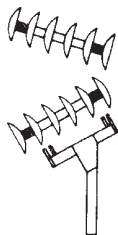

FIGURE 02

* When roller bearings in oil bath, they should be assembly with the lubrication system (plug) turning to the back of implement, as shown in Figure 03.

8 - The figures 4, show the sections discs assembly for each harrow model.



GRI/GRPI 12 DISCS

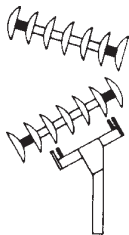

GRI/GRPI 14 DISCS

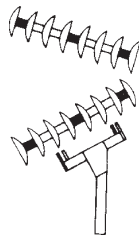

GRI/GRPI 16 DISCS

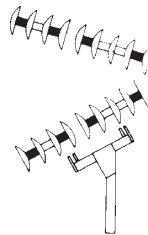

GRI/GRPI 18 DISCS

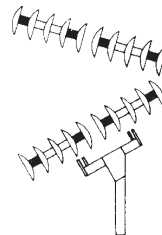

GRI/GRPI 20 DISCS

9 - Assemble the frame with the section of the disc and check that the mounting bracket bearings (shoe) should be face to the concavity of the discs, **as shown in Figure 05.**

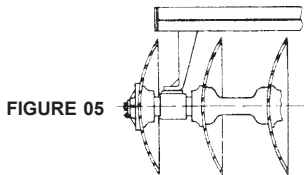
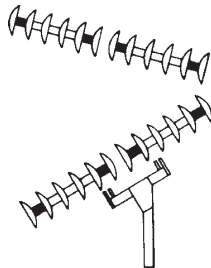
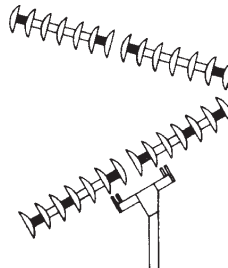

FIGURE 05



GRI/GRPI 24 DISCS



GRI 28 DISCS

FIGURES 04

LEGEND

■ = BEARING

□ = SPOOL

∩ = DISC

JOIN OF FRONT AND REAR FRAMES

10 - Attaching the front frame section item 1 in the rear frame section item 2, through the axis of join item 3, locking it with the bolt lock item 4, as shown in **Figure 06**.

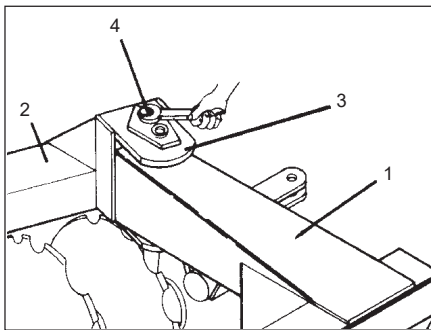

FIGURE 06

ASSEMBLY OF REGULATION OPENNING SET OF DISC HARROW WITH 12, 14 AND 16 DISCS

11 - Place on the front frame item 1, pull handle item 2, with the pin item 3, pass the ruler lock item 4 through the inner of the handle lock body, joining the rear section item 5 through bolt item 6, as shown the **Figure 07**.

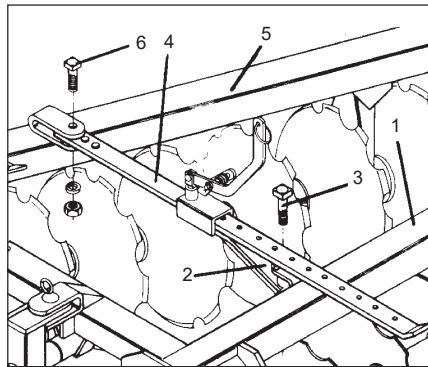

FIGURE 07

ASSEMBLY OF REGULATION OPENNING SET OF DISC HARROW WITH 18, 20, 24 AND 28 DISCS

12 - Place on the front frame item 1, the front stabilizer bar item 3, through the join pin item 4.

13 - Place on rear frame item 2, the rear stabilize bar item 5, through the join pin item 7.

14 - Coupling the front stabilizer bar item 3 and rear item 5, through the join pin item 7.

15 - Place the pull handle item 8, on right stabilizer bar, passing the strip lock adjustment item 9, by the inner of the handle lock body, joining it to the rear stabilizer bar through the bolt item 10, **as show in Figure 08.**

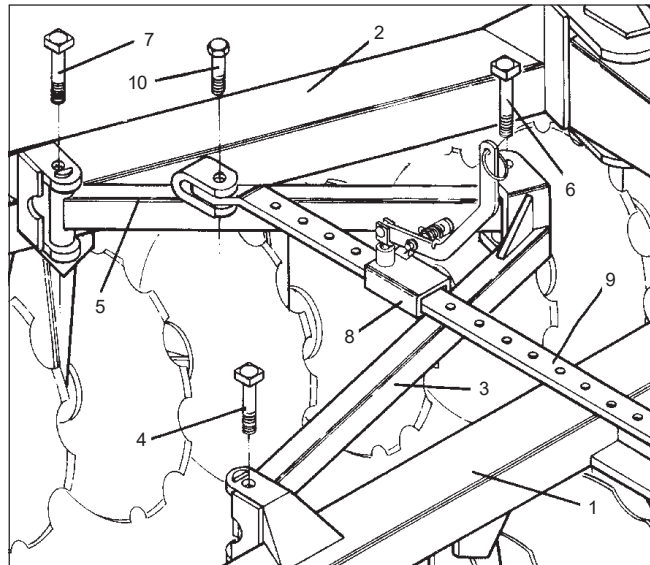

FIGURE 08

HEAD OF HITCH ASSEMBLY

16 - Place the transversal bar item 2 on front frame item 1 with bolts item 3.

17 - Place the header coupling item 4, joining the transversal bar through the bottom place and top item 5, with screws item 6.

18 - When the harrow has tires, put the handle latch header item 7 on the cross bar item 2 and front frame item 1, **as show in Figure 09.**

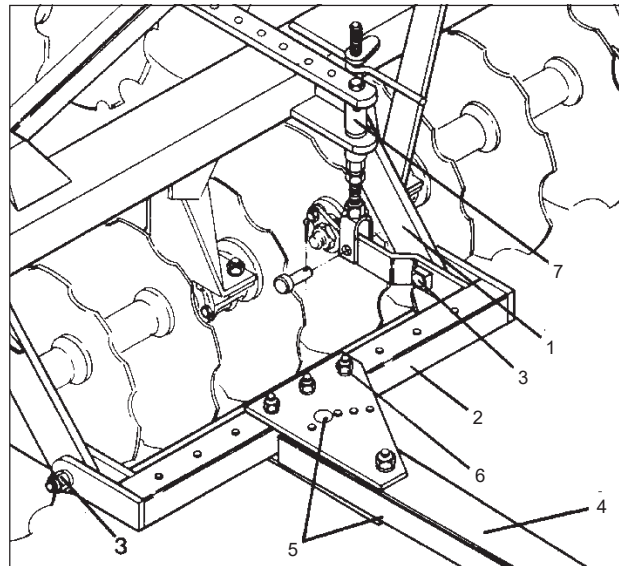

FIGURE 09

HITCH OF STABILIZER BAR

19 - The assembly of the stabilizer bars follow the same as harrows without piston, adding the assembly as follows:

- Place the piston 11, so that the base of the cylinder is placed in front stabilizer bar, item 3, through the pin, item 12, locking it with bolt, item 13, and piston handle fixed to the rear stabilizer bar, item 5 through the pin, item 14, locking with bolt, item 15, as shown in **Figure 10**.

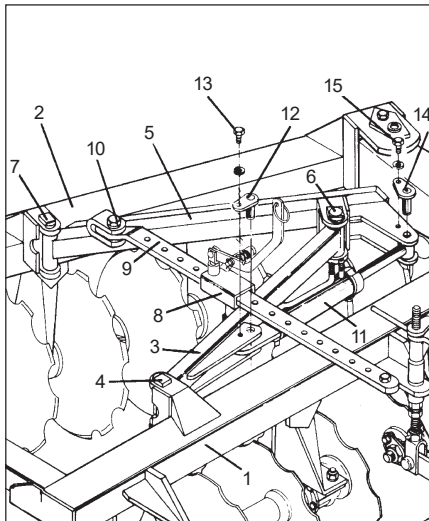

FIGURE 10

WHEEL HITCH

20 - Set the wheel item 1 the hub, through the nuts item 2.

21 - Place the lock pin wheel item 3 on frame, as shown in **Figure 11**.

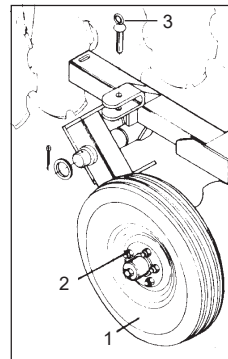

FIGURE 11

SCRAPER ASSEMBLY

22 - Set the scrapers item 1 in the front and rear frames, with bolts item 3, as shown in **Figure 12**.

23 - Note in the figure that, in the spacing where the bearings are fixed, there is no needs of scrapers.

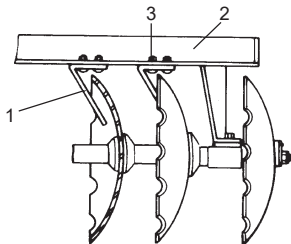

FIGURE 12

04 - HARROW HITCH

1 - To hitch the harrow on the drawbar of the tractor, must check the alignment, adjust the exact height of the hitch of the harrow, use the L coupling pin and cotter pin it as shows in **Figure 13**.

2 - To hitch the harrow, find a safe place and easily accessible, always use low gear at low speed.

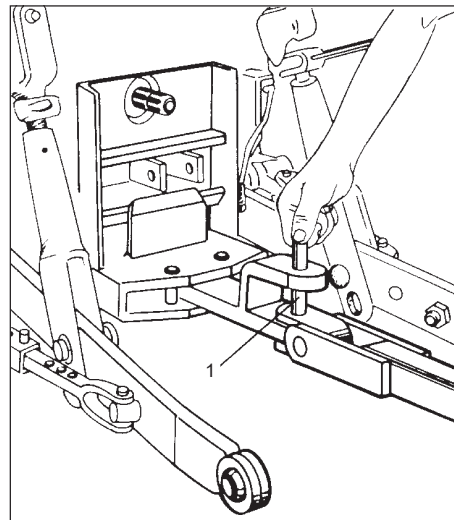

FIGURE 13

05- ADJUSTMENT AND OPERATIONS

ADJUSTMENT OPENING

- 1 - To obtain an idel penetration of the discs, the opening of the harrow varies according with the type of soil.
- 2 - In the land of greater difficulty of penetration increases the opening "A" of harrow, **as shown in Figure 14.**
- 3 - In the soft terrain and loose, you must work with a smaller opening.
- 4 - To open or close the harrow, pull the rope that goes until to the driver, releasing the adjustment of the opening set. To open the harrow, move the tractor forward and backward to close the harrow.
- 5 - For transport, close the harrow completely.



NOTE

Increasing the angle "A", greater penetration.
Decreasing the angle "A", smaller penetration.

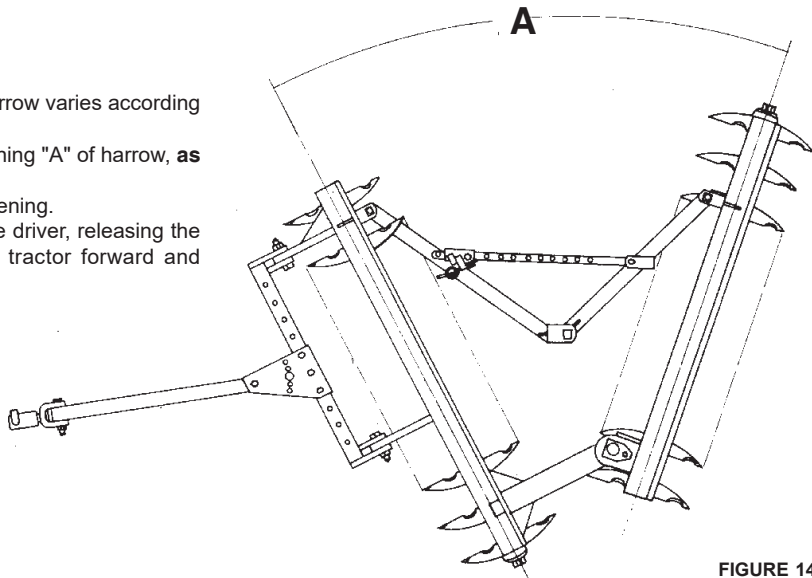
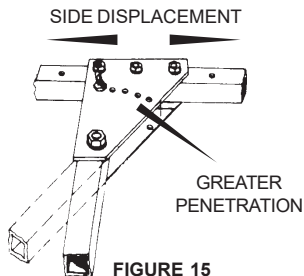

FIGURE 14

LATERAL DISPLACEMENT OF HARROW

6 - This movement should be regulated when the harrow is not giving a perfect finish, so keeping the tractor track. The harrow should work centralized with the central line of tractor. To do this, move the plates above and below the header to the right or left, **as shown in Figure 15**.

7 - The header coupling works in the center hole of the upper and lower plates for medium soil, displacing to the other holes change the angle attack of the front section.



ADJUSTMENT OF CROSS ON FRONT FRAME

8 - In the front frame are welded the front linkage arms, which has two, **holes as shown in Figure 16**, whose main purpose is the leveling of the harrow header in relation to the bar of the tractor.

NOTE: When hitched in top hole the penetration will be greater and consequently in the lower hole, the penetration will be smaller. For harrows with tires, when changing the hole, also change the handle latch header hole.

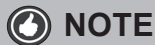
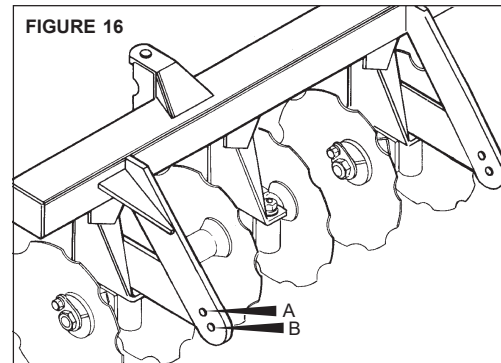

"A" - Greater penetration.
"B" - Smaller penetration.

TRANSPORT (FOR HARROWS WITH TIRES)

5 - To transport the harrow, remove the lock item 1 and the pin item 2 that locks the wheel support item 3. Then lower the wheel support item 3 to the ground. Then place the pin item 4 in hole of wheel support item 3 the way that is between the ribs of the wheel hub item 5 locking it.

6 - Then move the tractor slowly forward until the wheel support item 3 lifts the harrow and stays parallel to the lock.

7 - Then, place the pin item 2 and the lock item 1 locking the wheel support item 3. Take off the pin item 4 from the hole of wheel support item 3, unlocking the wheel hub item 5, **as shown in the Figures 17.**

8 - Before to start the transport, level the harrow adjusting the regulator item 6.

NOTE

After transport, repeat the above procedure in reverse order, before working with the grid again.

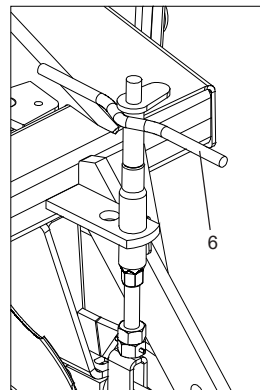
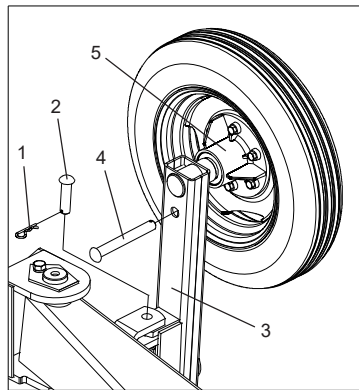
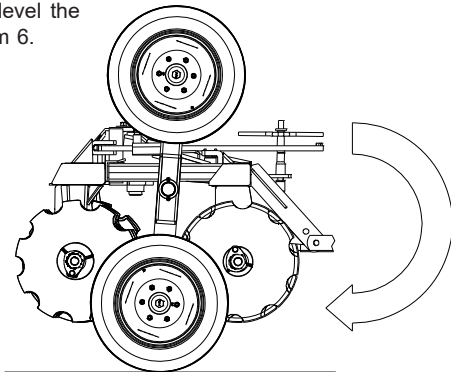

FIGURES 17

OPERATIONS

- 1 - Before start the operations with the harrow, review it completely, retighten all bolts, nuts, hoses terminals, axes and especially the disc section.

HOW TO START THE HARROWING

2 - At the start the harrowing should always follow the contour terraces or string, starting the operation in order to get the roof on the left side of the tractor driver.

- 3 - Do not turn to the right side, look the figure 18. The harrowing ground should always be to the left of the tractor driver.

- 4 - In the following figure we will show some systems of operations.

HARROWING INSIDE OUTWAY

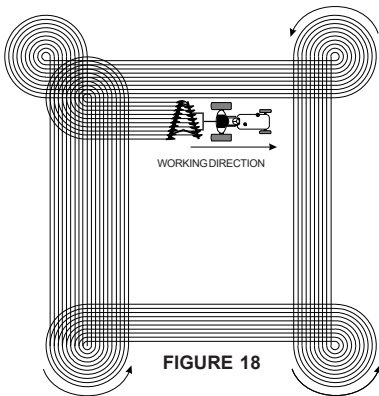

HARROWING TOWARDS INSIDE OUT

In this way we obtain greater perfection. When you're walking in the headwaters should be very

carefully to start other block.

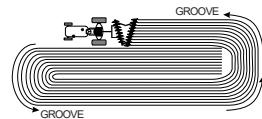

PLOTS WITH LINE

In terrain with contour plots is usual to get two plots at time, taking care to start the work with the contour of the left side of the tractor driver. When you get in the middle of the contour, is should have another plot to reduce fuel consumption.

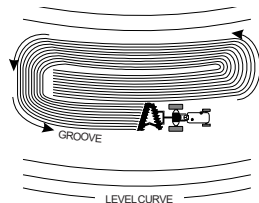

FIGURE 18

4 - Hourly production can vary due to some factors that change the work rate, such as: Moisture and hardness of the soil, slope of the ground and inadequate adjustments.

5 - The F factor, is to discount the work position, maneuvers, efficiency drops after prolonged periods of work, etc.



NOTE

The value of the production factor is different from one implement to the other and is directly linked to the type of soil, size of area, operator, etc.

06 - TIRES PRESSURE

1 - **GRPI** has tires. The tires must always be correctly calibrated, avoiding premature wear due to excess or lack of pressure.



GRPI
TIRES 600x16 6 lonas
USE: 44 lbs/pol².

FIGURE 19



ATTENTION

Never weld the tire-mounted wheel, heat can cause an increase in air pressure and cause the tire to explode.

When inflating the tire, position yourself next to the tire, never in front of it.

When inflating the tire, always use a containment device (inflation cage).



IMPORTANT

When inflating tires, do not exceed the recommended inflation.



NOTE

The tire pressure of the tractor must be made according to the manufacturer's recommendation.

07 - LUBRICATION

- 1 - Lubrication is essential for good performance and longer durability of the moving parts of the implements.
- 2 - Before starting work, carefully lubricate all grease fittings, always observing the relubrication intervals, making sure the quality of the lubricant, as to its efficiency and purity, avoiding using products contaminated by water, soil, etc.

LUBRIFICATION OF ROLLER BEARINGS IN GREASE

<i>MANUFACTURER</i>	<i>TYPES OF GREASE RECOMMENDED</i>	<i>NOTE</i>
<i>PETROBRÁS ATLANTIC IPIRANGA CASTROL TEXACO SHELL ESSO</i>	<i>LUBRAX GMA2 ALUBRIFICANT 54 SUPER GRAXA IPIRANGA MOBILGREASE MP MARFAK 2 RETINAXA MULTIPURPOSE GREASE H</i>	

TABLE 01

LUBRIFICATION OF ROLLER BEARINGS IN OIL BATH

- 6 - In the first days of working with the grid, check the oil level of the bearings daily and also the retainers.
- 7 - Check the oil level after every 120 hours of work.
- 8 - The oil change must be done every 1200 hours of work. Use SAE 90 mineral oil.

08 - LUBRICATION POINTS

TABLE 02

ITEM	PARTS DESCRIPTION	NUMBER OF LUBRICATION POINTS							CHANGE OIL	LUBR. W/ GREASE	RETIGHT	REPLACE	CHECK	MAINTENANCE INTERVALS
		GRI / GRPI 12 DISCS	GRI / GRPI 14 DISCS	GRI / GRPI 16 DISCS	GRI / GRPI 18 DISCS	GRI / GRPI 20 DISCS	GRI / GRPI 24 DISCS	GRI 28 DISCS						
1	Bearings	4	4	6	8	8	8	8		X				12 hours
2	Piston articulation pin	2	2	2	2	2	2	2		X				
3	Handle frame	1	1	1	1	1	1	1		X				
4	Piston handle	1	1	1	1	1	1	1		X				60 hours
5	Stabilizer bar join	1	1	1	1	1	1	1		X				
6	Rear stabilizer bar			1	1	1	1	1		X				
7	Piston hitch	1	1	1	1	1	1	1		X				
8	Front stabilizer bar	1	1	1	1	1	1	1		X				
9	Lock pull	1	1	1	1	1	1	1		X				
10	Wheel hub	2	2	2	2	2	2	2						
11	Hydraulic system												X	
12	Bolts / Nuts										X			120 hours
13	Bearings oil								X					1200 hours
14	Roller / Retainers											X		1500 hours
15	Discs / Tyres / Bearings											X		When necessary

OPTIONAL

OPENNING SYSTEM WITH HYDRAULIC SYSTEM

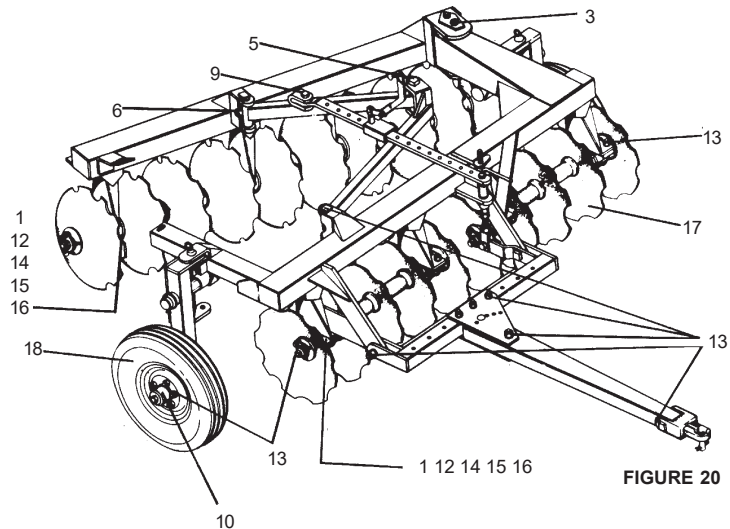
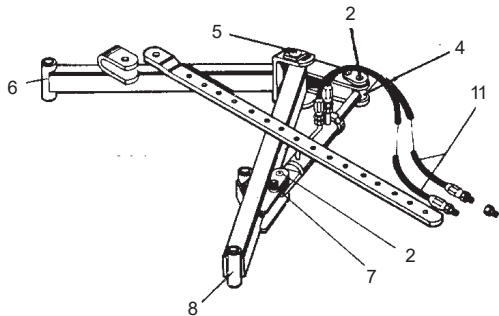

FIGURE 20



ATTENTION

After the first day of work, retight all the bolts and nuts.

09 - BEARINGS ADJUSTMENTS

11 - When the bearing shows looseness, adjust them as follows:

- Remove the washer item 1 in Figure 21.
- Loosen the bolts item 2 and take off the cover item 3.
- Remove 1 or 2 joints item 4, from the bearing cover.
- Replace the cap and retighten it.

12 - If the loose persists, we can facemills the cover item 3, to increase the regulation, after assembly it the same on bearing with many joints are needed.

13 - The bearings must rotate free, so, without radial or axial clearances.

10 - CLEANING

1 - When the harrow remain inactive for an extended period, make a clean sweep in it, make sure if the ink wear off. If this happend, give an overall coat, use protective and lubricating oil to the harrow completely. Check the discs, give a coat of paint on them and use protective oil.

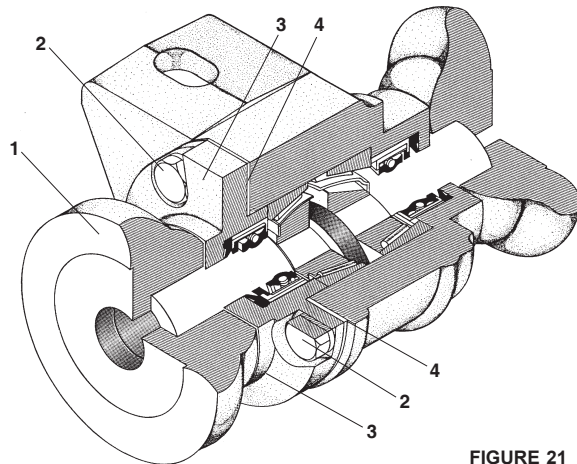

FIGURE 21



ATTENTION

Do not assembly the bearing without joints.

11 - SPARE PARTS

1 - Look for your Baldan dealer in your region, he will have genuine parts in stock.

12 - APPROX PRODUCTION OF GRI / GRPI HARROWS

1 - To calculate the approx hourly output of harrows, use the follow:

$$A = \frac{L \times V \times F}{X}$$

Where:

A = Area to be worked

L = Work width of harrow (meters)

V = Average speed tractor (meters)

F = Output factor: 0.90

X = Value of the Hectare: 10.000 m²

2 - **Ex.:** The **GRI / GRPI** 24 discs, how much Ha it will produce in a hour of work at an average speed of 7 km/h.

A = ?

L = 2,70 m

V = 7.000 m/h

F = 0,90

X = 10.000 m² (calculated in hectare)

$$A = \frac{2,70 \times 7000 \times 0,90}{10.000} = 1,70 \text{ Ha/h}$$

3 - APPROXIMATE TABLE OF HOURLY PRODUCTION

TABLE 03

MODEL	WORKING WIDTH (m)	AVERAGE SPEED (m/h)	OUTPUT FACTOR	APPROX. OUTPUT:
				Hectares
GRI - 12	1.30	7.000	0,90	0,81
GRI - 14	1.55	7.000	0,90	0,97
GRI - 16	1.75	7.000	0,90	1,10
GRI - 18	2.00	7.000	0,90	1,26
GRI - 20	2.25	7.000	0,90	1,41
GRI - 24	2.70	7.000	0,90	1,70
GRI - 28	3.20	7.000	0,90	2,01
GRPI - 12	1.30	7.000	0,90	0,81
GRPI - 14	1.55	7.000	0,90	0,97
GRPI - 16	1.75	7.000	0,90	1,10
GRPI - 18	2.00	7.000	0,90	1,26
GRPI - 20	2.25	7.000	0,90	1,41
GRPI - 24	2.70	7.000	0,90	1,70

13 - TECHNICAL SPECIFICATIONS

TABLE04



MODEL	NR OF DISCS	DIAMETER OF DISCS Ø	SHAFT DIAMETER Ø	WORKING WIDTH (mm)	SPACING BETWEEN DISCS (mm)	WORKING DEPTH (mm)	TIRES	APPROXIMATE POWER 24" (kg)	APPROXIMATE POWER 26" (kg)	TRACTOR POWER (cv)
GRI	12	24" - 26"	1.5/8"	1500	270	150 to 250		919	1011	73 to 75
GRI	14	24" - 26"	1.5/8"	1750	270	150 to 250		1020	1127	79 to 85
GRI	16	24" - 26"	1.5/8"	2000	270	150 to 250		1317	1414	95 to 108
GRI	18	24" - 26"	1.5/8"	2300	270	150 to 250	-	1477	1578	110 to 112
GRI	20	24" - 26"	1.5/8"	2550	270	150 to 250		1596	1644	116 to 126
GRI	24	24" - 26"	1.5/8"	3100	270	150 to 250		1791	1842	143 to 152
GRI	28	24" - 26"	1.5/8"	3650	270	150 to 250		2056	2143	160 to 180
GRPI	12	24" - 26"	1.5/8"	1500	270	150 to 250		1390	1425	73 to 75
GRPI	14	24" - 26"	1.5/8"	1750	270	150 to 250		1460	1503	79 to 85
GRPI	16	24" - 26"	1.5/8"	2000	270	150 to 250	Simple 600x16	1598	1641	95 to 108
GRPI	18	24" - 26"	1.5/8"	2300	270	150 to 250		1710	1760	110 to 112
GRPI	20	24" - 26"	1.5/8"	2550	270	150 to 250		1785	1840	116 to 126
GRPI	24	24" - 26"	1.5/8"	3100	270	150 to 250		1920	1990	143 to 152

Baldan reserves the right to change and/or perfect the technical characteristics of its products, without previous notice, and without obligation to proceed in the same way with the products previously manufactured. Technical specifications are approximate and informed under normal work conditions.

14 - IDENTIFICATION

1 - In order to refer parts catalogues or apply technical support from Baldan, always indicate model (1), serial number (2), manufacture date (3) located on the identification tag.

2 - ALWAYS REQUIRE BALDAN ORIGINAL PARTS.

 BALDAN		
BALDAN IMPLEMENTOS AGRÍCOLAS S/A. AV. BALDAN, 1500 NOVA MATÃO CEP 15.993-900 MATÃO-SP BRASIL FONE: (16) 3221-6500 CNPJ: 52.311.347/0009-06 CREA/SP 0170977		
1	Modelo / Model	Data / Date
2	Nº de Série / Serial Number	Tipo / Type
	Capacidade / Load Capacity	Peso / Weight

3

 **ATTENTION**

The drawings in this instruction manual are for illustrative purposes only.



PUBLICATIONS

Code: 60550200786
CPT: GRIGRPI07516



CONTACT

If you have questions, never operate the GRI / GRPI see the post sale.
Phone: 0800-152577
E-mail: posvenda@baldan.com.br

PRODUCT IDENTIFICATION

Please make the correct identification of the data below, to always have information about the service life of your **GRI / GRPI**.

Owner: _____

Dealer: _____

Property: _____

City: _____ State: _____

Certificate of Warranty no.: _____

Implement: _____

Serial No: _____

Purchase Date: ____ / ____ / ____ NF. N°: _____

CERTIFICATE OF WARRANTY

BALDAN IMPLEMENTOS AGRÍCOLAS S/A, guarantee the normal operation of the product for a 6 (six) months period dated from the dealers's bill of sale to the first final customer.

During this period **BALDAN** compromise it self to repair the material or manufacturing defects, but the labour, the freight and other expenses are the dealer's responsibility.

At the garantee period, all the request and replacement of any defective part must be made to the dealer of the region, which will send the defective part for analysis at **BALDAN**.

When this procedure won't be possible and the dealer couldn't have the ability to solve the problem, the dealer can ask for **BALDAN'S TECHNICAL ASSISTANCE** using the specific form delivered to them.

After the analysis of the items replaced by **BALDAN TECHNICAL ASSISTANCE** and if we conclude that it wasn't a guarantee problem, then the dealer will be the responsible for all costs related to the replacement; as well as material expenses, travel including accommodation and meals, also the accessories, lubricant used or any other expenses after having called the Technical Assistance. And, withal, the company Baldan is authorized to issue the billing in name of the respective reseller.

Any repair made to the product wich is in warranty period by the dealer, will only be authorized by **BALDAN** after budget previous presentation describing pieces and labour to be accomplished.

It is out of this term the product wich has repairs or modifications not made by dealers from **BALDAN'S** network, as well as pieces applications or not authentic components to the product by the user.

This certificate of guarantee will became invalid when notice that the damage or defect is the result of incorrect use of the product, of instructions non-observance or operator's inexperiences.

It's stipulated that this guarantee don't cover tires, polyethylene deposits, universal joints, hydraulic components, etc, wich equipments are guarantee by their manufacturers.

The material or manufacturer defects, object of this certificate of guarantee, will not be, by any hypotesis, reason for cancelation of the contract of sale, or indemnity of any kind.

For a warranty solicitation to the distributor, you have to proceed in the following manner:

Send the technical informe detailed telling the problem (technical assistance request form to the client), you cand find it send us an email to aftersales@baldan.com.br or acessing our website.

If it's possible send films and photos from the requested spare parts.

CERTIFICATE OF WARRANTY

To point at the form: serial number, manufacturer year, etc, that is, all information asked at the form. The damaged spare parts should be available for analysis of the sales department in a future visit (in case of request).

BALDAN keeps the right of changing and or improve the technical characteristic of its products, without notice and without the obligation of act like this way with its previously manufactured products.

INSPECTION AND DELIVERY CERTIFICATE

SERVICE BEFORE THE DELIVERY: This equipment was very carefully prepared by the dealer's organization, inspected in all its parts in agreement with the manufacture's prescription.

DELIVERY SERVICE: The user was informed about the current guarantee terms and instructed about maintenance care and utilization.

I confirm that i was informed about the current guarantee terms and instructed about the correct utilization and maintenance of this product.

PRODUCT _____ SERIAL NUMBER _____

DATE _____ BILL OF SALE _____ STORE _____

CITY _____ STATE _____ ZIP CODE _____ PHONE _____

OWER _____

ADRESS _____ N° _____

CITY _____ STATE _____

E-MAIL _____

DATE OF SALE

SIGNATURE / STORE'S STAMP

INSPECTION AND DELIVERY CERTIFICATE

SERVICE BEFORE THE DELIVERY: This equipment was very carefully prepared by the dealer's organization, inspected in all its parts in agreement with the manufacture's prescription.

DELIVERY SERVICE: The user was informed about the current guarantee terms and instructed about maintenance care and utilization.

I confirm that i was informed about the current guarantee terms and instructed about the correct utilization and maintenance of this product.

PRODUCT _____ SERIAL NUMBER _____

DATE _____ BILL OF SALE _____ STORE _____

CITY _____ STATE _____ ZIP CODE _____ PHONE _____

OWER _____

ADRESS _____ Nº _____

CITY _____ STATE _____

E-MAIL _____

DATE OF SALE

SIGNATURE / STORE'S STAMP

INSPECTION AND DELIVERY CERTIFICATE

SERVICE BEFORE THE DELIVERY: This equipment was very carefully prepared by the dealer's organization, inspected in all its parts in agreement with the manufacture's prescription.

DELIVERY SERVICE: The user was informed about the current guarantee terms and instructed about maintenance care and utilization.

I confirm that i was informed about the current guarantee terms and instructed about the correct utilization and maintenance of this product.

PRODUCT _____ SERIAL NUMBER _____

DATE _____ BILL OF SALE _____ STORE _____

CITY _____ STATE _____ ZIP CODE _____ PHONE _____

OWNER _____

ADDRESS _____ N° _____

CITY _____ STATE _____

E-MAIL _____

DATE OF SALE

SIGNATURE / STORE'S STAMP

3ª PAGE - MANUFACTURER

Please send this filled copy to Baldan, until 15 days after the purchase.



Avenida Baldan, 1500
Nova Matão
15.993-900
Matão/SP - Brasil
sac@baldan.com.br
export@baldan.com.br

+55 16 3221 6500
baldan.com.br