

# SAB/SHB

Series 2000 / 2300 / 2600 / 3000



## Instruction Manual



[www.baldan.com.br](http://www.baldan.com.br)



## INTRODUCTION

**W**e appreciate your purchase and congratulate you for the excellent choice you just made because you have purchased a product manufactured with technology from **BALDAN IMPLEMENTOS AGRÍCOLAS S/A**.

This instruction manual will guide you through the procedures that are necessary since its acquisition up to the operating procedures of use, security and maintenance.

**BALDAN** ensures that has delivered this farming implement to the dealer in perfect conditions.

The dealer is responsible for the custody and maintenance of this farming implement and also for the assemblage, retightening, lubrication and overhaul.

In the technical delivery, the dealer must advise the user on its maintenance, security, its obligations under any technical assistance, the strict observance of the guarantee and reading of the instruction manual.

Any request for technical assistance under warranty should be made to the dealer where it was purchased.

We reiterate the need for careful reading of the **Warranty Certificate** and observance of all items in this instruction manual, as doing so, the useful life of your farming implement will increase.



# ***Instruction Manual***



# INDEX

<b>01 - SAFETY STANDARDS .....</b>	<b>5 a 8</b>
<b>02 - COMPONENTS</b>	
<i>SAB - Baldan drag-type crop planter .....</i>	<i>9</i>
<i>SHB - Baldan hydraulic crop planter .....</i>	<i>10</i>
<b>03 - TECHNICAL SPECIFICATIONS .....</b>	<b>11</b>
<b>04 - ASSEMBLY</b>	
<i>Coupling header .....</i>	<i>12</i>
<i>Fine seed box - Optional .....</i>	<i>13</i>
<b>05 - TRACTOR HOOKUP</b>	
<i>Drag coupling .....</i>	<i>14</i>
<i>Hydraulic coupling .....</i>	<i>15</i>
<i>TSHB Work / transport .....</i>	<i>16 a 17</i>
<i>SAB Work / transport .....</i>	<i>17</i>
<b>06 - ADJUSTMENTS</b>	
<i>SHB Centralization .....</i>	<i>18</i>
<i>SHB Leveling .....</i>	<i>18</i>
<i>Pressure regulation of the SHB wheel set A .....</i>	<i>19</i>
<i>Adjustments of the SHB wheel set .....</i>	<i>20</i>
<b>07 - SEED DISTRIBUTION</b>	
<i>Seed regulation .....</i>	<i>21</i>
<i>Table for seed distribution .....</i>	<i>22</i>
<i>Adjustment of the fine seed box - Optional .....</i>	<i>23</i>
<b>08 - FERTILIZER DISTRIBUTION SYSTEM</b>	
<i>Metallic fertilizer tank .....</i>	<i>24</i>
<i>Table for fertilizer distribution per linear meter SAB / SHB .....</i>	<i>25</i>
<b>09 - PRACTICAL CALCULATION FOR FERTILIZER DISTRIBUTION</b>	
<i>Practical test to measure the distribution amount of seed and fertilizer .....</i>	<i>26</i>
<b>10 - STIRRING SYSTEM</b>	
<i>Seed stirring system - optional .....</i>	<i>27</i>
<b>11 - PLANTING LINES</b>	
<i>Models of lines.....</i>	<i>28 a 29</i>
<i>Optional wheel models .....</i>	<i>30</i>
<i>Assembly of compaction wheels.....</i>	<i>31</i>
<i>Adjustment of the working depth .....</i>	<i>31</i>
<i>Depth limiting frame - Optional .....</i>	<i>32</i>
<i>Assembly of the Depth limiting frame – Optional .....</i>	<i>32</i>
<i>Adjustment of compaction wheels .....</i>	<i>33</i>
<b>12 - OPERATIONS .....</b>	<b>33</b>



## 13 - MAINTENANCE

<i>Tire pressure</i> .....	34
<i>Lubrication</i> .....	35
<i>Table of grease and equivalents</i> .....	35
<i>Lubricate every 10 hours of work</i> .....	36
<i>Lubricate every 30 hours of work</i> .....	36
<i>Lubricate every 60 hours of work</i> .....	36
<i>Lubricate every 200 hours of work</i> .....	37
<i>Tension of chains</i> .....	37
<i>Operational maintenance</i> .....	38
<i>Care</i> .....	39
<i>General cleaning</i> .....	39

## 14 - IDENTIFICATION

<i>Product identification</i> .....	40
-------------------------------------	----

## 01 - SAFETY STANDARDS



THIS SYMBOL INDICATES IMPORTANT SAFETY WARNING. WHENEVER YOU FIND IT IN THIS INSTRUCTION MANUAL, CAREFULLY READ THE MESSAGE THAT FOLLOWS AND BE AWARE OF THE POSSIBILITY OF PERSONAL INJURY.

### ATTENTION

- Read the instruction manual carefully, so you can learn the recommended safety practices.

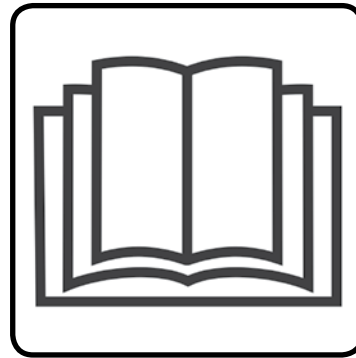

### ATTENTION

- Do not operate the tractor if the front is light. With a tendency to rise, add weights on the front of the tractor or front wheels.



### ATTENTION

- Only begin operating the tractor when are properly accommodated and with the seat belt fastened.



### ATTENTION

- There are risks of serious injury by tumbling when working on slopes.
- Do not use excessive speed.

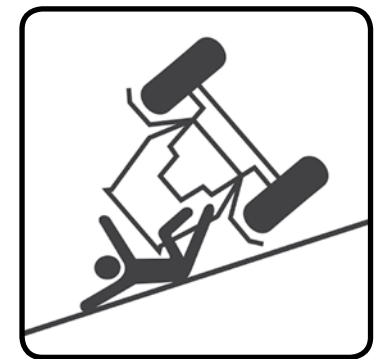

**! ATTENTION**

- Do not operate the planter if protections of transmissions are not properly fixed.
- Only remove the protections to make the switch gear, replace them immediately.
- When making any service in the planter transmission, disable the turnpikes.
- Do not make adjustments with the planter in motion.

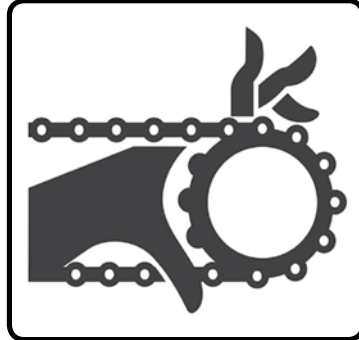
**! ATTENTION**

- When looking for a possible leak in the hoses, use a piece of cardboard or wood, never use your hands.
- Avoid the incision of fluid in the skin.

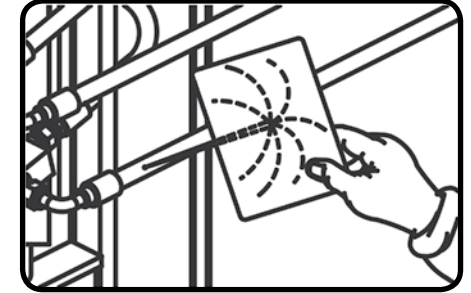
**! ATTENTION**

- Keep yourself away from the active elements of the planter (disks), because they are sharp and can cause accidents.
- When making any service on the disks, use safety gloves.

**! ATTENTION**

- Before performing any maintenance on your equipment, make sure it is turned off. Avoid getting hit.

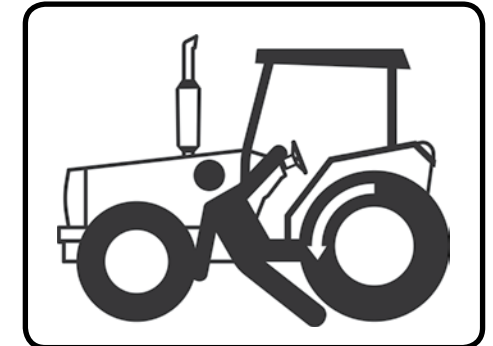

ALCOHOL OR DRUGS CAN GENERATE SOME LOSS OF REFLEXES AND CHANGE THE OPERATOR'S PHYSICAL CONDITIONS. SO, NEVER OPERATE THIS EQUIPMENT UNDER USE OF THESE SUBSTANCES.

## **ATTENTION**

- The hydraulic oil works under pressure and can cause serious injury, in case of any leaks. Periodically check the conservation status of hoses. If there is evidence of leakage, replace them immediately.
- Before connecting or disconnecting the hydraulic hoses, relieve the system pressure, triggering the command with the tractor off.



## **ATTENTION**

- When operating the planter, do not let people on the machine.
- Do not stand on the platforms with the planter is in motion.

















## **ATTENTION**

- Do not transport people on the tractor or equipment.



**WARNING**

The mismanagement of this equipment can result in serious or fatal accidents. Before placing the equipment in operation, carefully read the instructions in this instruction manual. Make sure that the person responsible for the operation is instructed on the proper and safe handling, if he has read and understood the instruction manual of this product.

- 01 -  When operating the equipment, do not allow people to stay very close to it.
- 02 -  In making any assembly and disassembly service in the discs, use safety gloves.
- 03 -  Do not wear loose clothing as they can curl up on the equipment.
- 04 -  When turning the tractor engine on, by properly seated in the operator's seat and be aware of the correct and safe management both of tractor and implement. Always put the shifter in neutral, turn off the engine and put the hydraulic command in the neutral position.
- 05 -  Do not turn on the engine indoors or without adequate ventilation, because the exhaust fumes are harmful.
- 06 -  When maneuvering the tractor to the implement coupler, make sure to have the necessary room and that there is nobody very close. Make maneuvering in low gear and be prepared to brake in an emergency situation.
- 07 -  Do not make adjustments with the implement in operation.
- 08 -  When working on slopes, proceed with caution when trying to maintain the necessary stability. In case of unbalance, reduce the throttle and turn the wheels of the tractor to the side of the slope.
- 09 -  Always drive the tractor at speeds compatible with safety, especially when working on uneven ground or slopes. Keep the tractor always engaged.
- 10 -  When driving on roads, keep the tractor brake pedals interconnected and use safety signs.
- 11 -  Do not operate the tractor if the front is light. If there is a tendency to rise, add weights on the front or front wheels.
- 12 -  When leaving the tractor, put the shifter in neutral and apply the parking brake.
- 13 -  Alcoholic beverages and some medications can cause loss of reflexes and change the operator's physical conditions. Therefore, never operate this equipment under the influence of these substances.
- 14 -  Read or explain all the procedures above to the operator who cannot read.

# SAB - BALDAN DRAG PLANTER

Figures 01

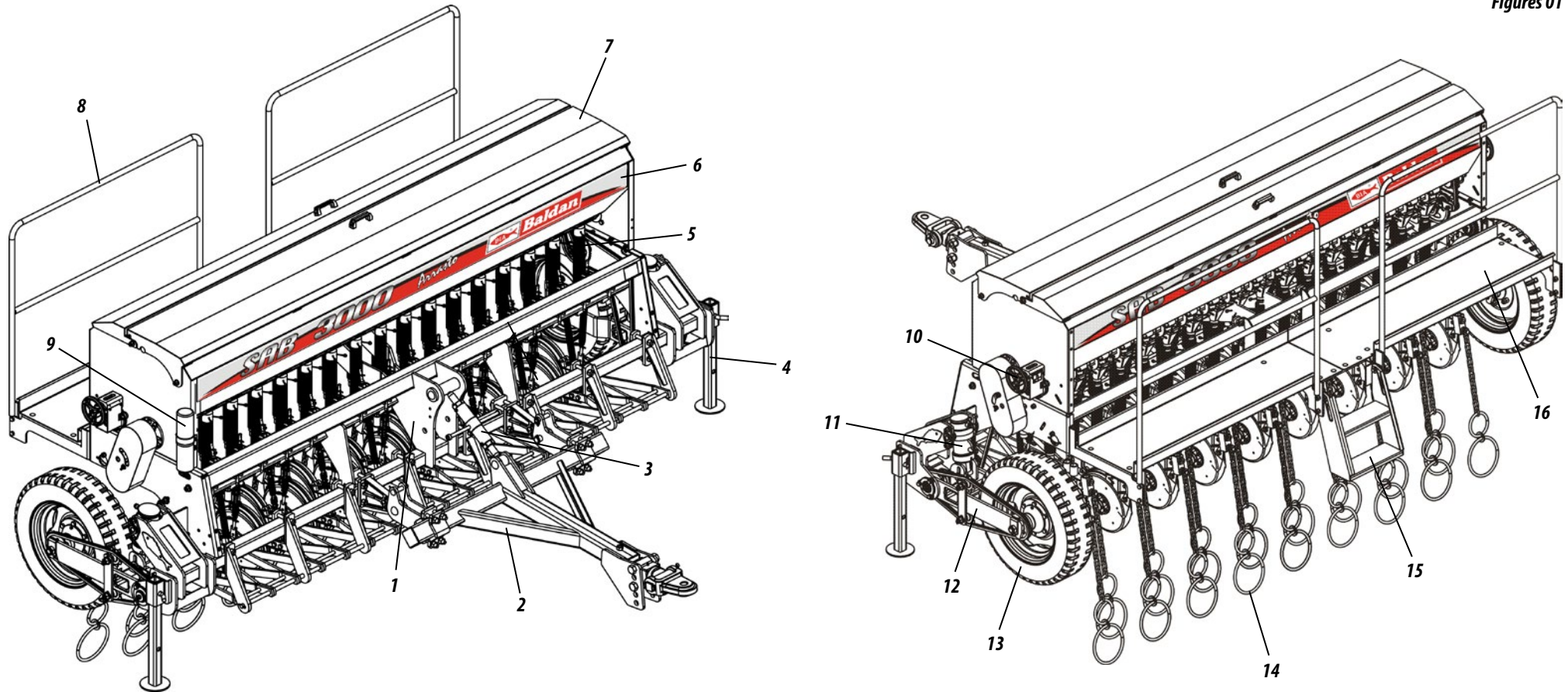

## 02 - COMPONENTS

- |                    |                              |                                    |                 |
|--------------------|------------------------------|------------------------------------|-----------------|
| 1- Chassis         | 5- Fertilizer conductor hose | 9- Manual Container and Catalogue  | 13- Tire        |
| 2- Coupling Header | 6- Adhesive                  | 10- Fine Seed Box Regulator        | 14- Drag Chains |
| 3- Regulator       | 7- Fertilizer and Seed Tank  | 11- Cylinder to lift the wheel set | 15- Ladder      |
| 4- Support bracket | 8- Platform Handrail         | 12- Wheel support                  | 16- Platform    |

**SHB - BALDAN HYDRAULIC PLANTER**

Figures 02

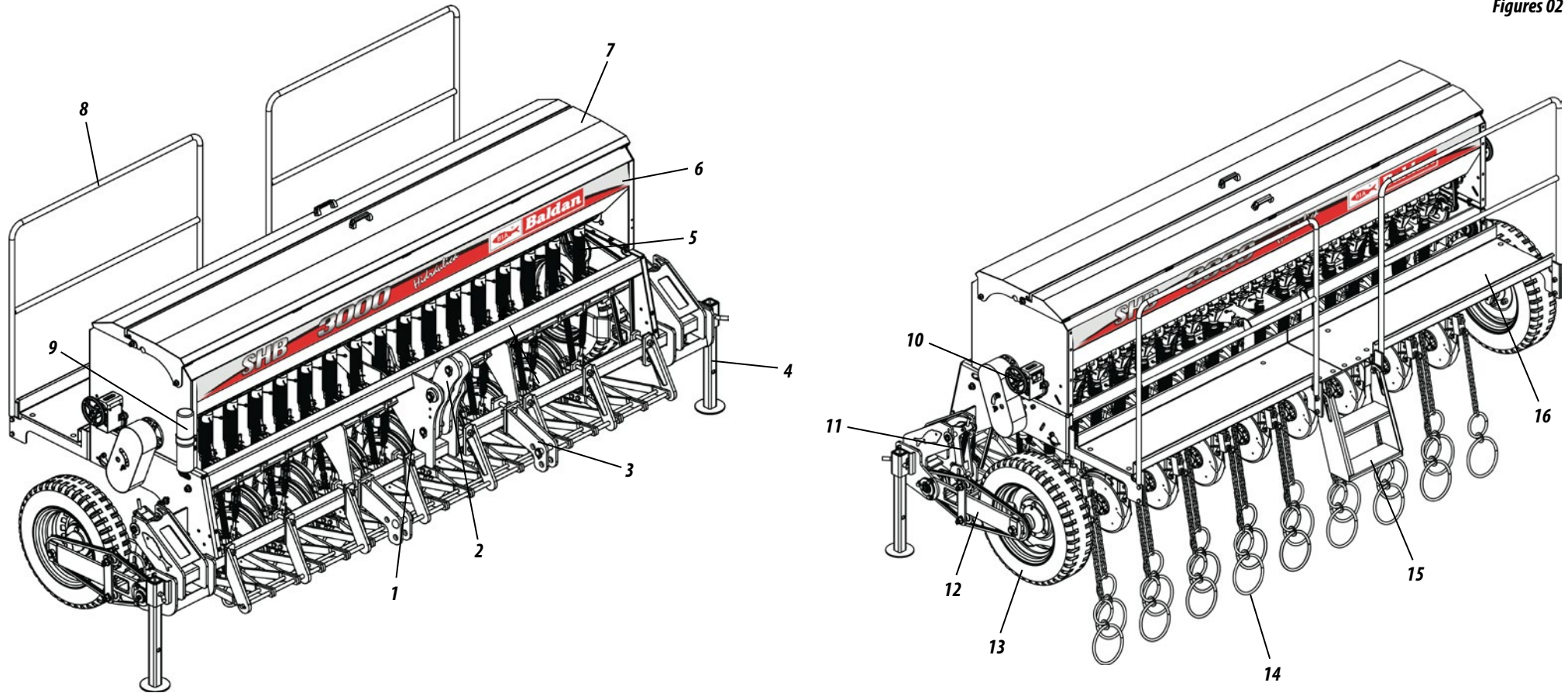

**02 - COMPONENTS**

- 1- Chassis
- 2- 3rd Point Support
- 3- Tractor Hitch
- 4- Support Bracket

- 5- Fertilizer conductor hose
- 6- Adhesive
- 7- Fertilizer and Seed Tank
- 8- Platform Handrail

- 9- Manual Container and Catalogue
- 10- Fine Seed Box Regulator
- 11- Cylinder to lift the wheel set
- 12- Wheel Support

- 13- Tire
- 14- Drag Chains
- 15- Ladder
- 16- Platform

## 03 - TECHNICAL SPECIFICATIONS

Table 01

Model	Nr. of discs	Fertilizer tank capacity (L)	Seed tank capacity (L)	Fine seed tank capacity (L)	Total width (mm)	Total height (mm)	Total length (mm)	Tractor coupler	Approximate weight (kg)	Approximate power (hp)
<b>SAB 2000</b>	11	333	182	35	2930	1952	2228	Drag	990	55
<b>SAB 2300</b>	13	366	210	40	3270	1952	2228	Drag	1080	65
<b>SAB 2600</b>	15	423	241	47	3610	1952	2228	Drag	1190	75
<b>SAB 3000</b>	17	468	297	54	3950	1952	2228	Drag	1290	85

Model	Nr. of discs	Fertilizer tank capacity (L)	Seed tank capacity (L)	Fine seed tank capacity (L)	Total width (mm)	Total height (mm)	Total length (mm)	Tractor coupler	Approximate weight (kg)	Approximate power (hp)
<b>SHB 2000</b>	11	333	182	35	2930	1793	1869	Hydraulic 3rd point	1135	55
<b>SHB 2300</b>	13	366	210	40	3270	1793	1869	Hydraulic 3rd point	1230	65
<b>SHB 2600</b>	15	423	241	47	3610	1793	1869	Hydraulic 3rd point	1330	75
<b>SHB 3000</b>	17	468	297	54	3950	1793	1869	Hydraulic 3rd point	1450	85

Minimum spacing between lines (mm) ..... 170  
 Assembly ..... Tubular structure

The BALDAN reserves the right to change technical specifications of this product without previous notice.  
 The technical specifications are approximate and informed under normal working conditions.

## 04 - ASSEMBLY

The Baldan SAB seeders leave the factory semi-assembled, with only a few components that must be assembled according to directions below:

### ASSEMBLY OF THE COUPLING HEADER (FIGURES 03/04) SAB 2000 / 2300 / 2600 / 3000

To assemble the coupling header in the SAB planter, proceed as follows:

- 1- Place the coupling header (1) in the working position, removing the lock w / ring (2) and pin (3) which were placed for transportation, as shown in figure 2.
- 2- Then, insert the regulator (4) into the coupling header (1), fixing with the pin (5) and lock w / ring (6) and the assembly support (7) with the pin (8) and lock w / ring (9), as shown in Figure 03.

Figure 03

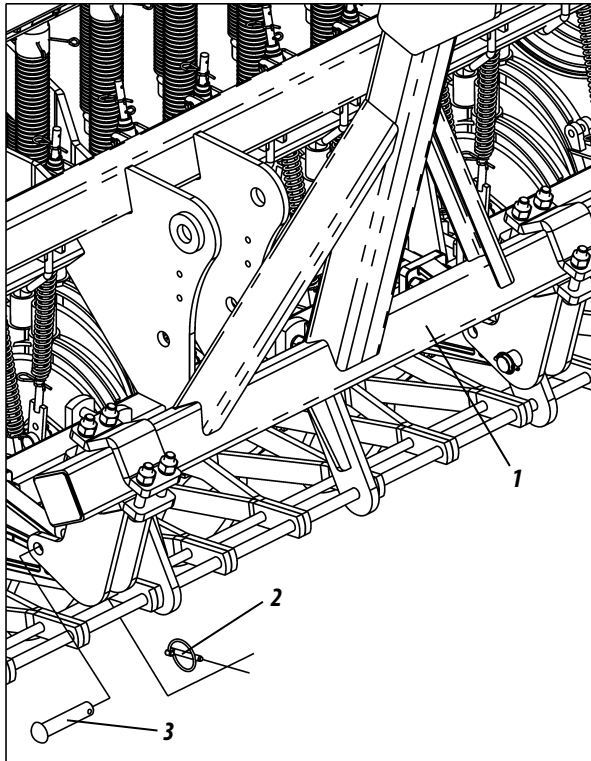
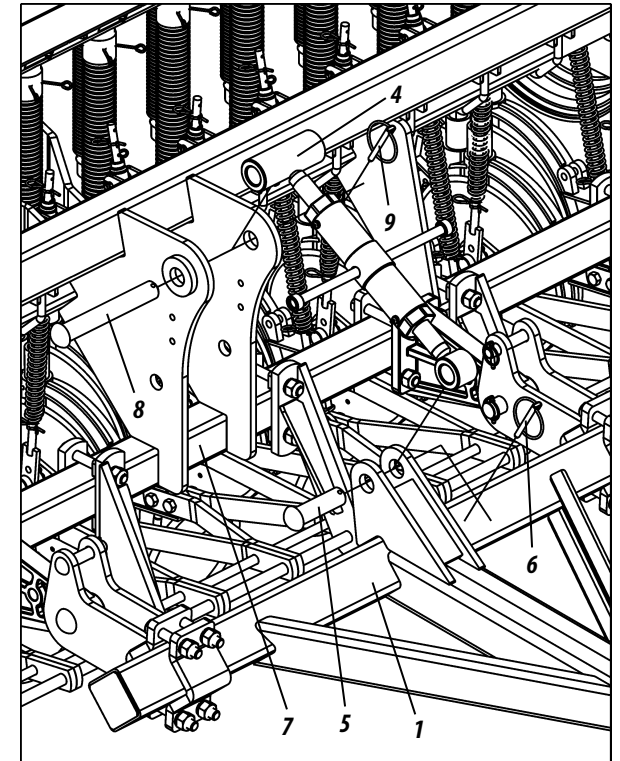

Figure 04



### IMPORTANT

*Before starting the assemblage of the coupling header, find an ideal place to facilitate the identification of components and assembly of the coupling header.*

## ASSEMBLAGE OF THE FINE SEED BOX - OPTIONAL (FIGURES 05/06/07) SAB / SHB 2000 / 2300 / 2600 / 3000

The Baldan SAB and SHB planters have accessories that may be purchased according to the need of work. The fine seed box is among the options available.

To assemble the fine seed box (1) in the fertilizer tank (2) of both SAB and SHB models, proceed as follows:

- 1- Attach the fine seed box (1) at the rear of the fertilizer tank (2) using screws (3), flat washers (4), pressure washers (5) and nuts (6).

Figure 05

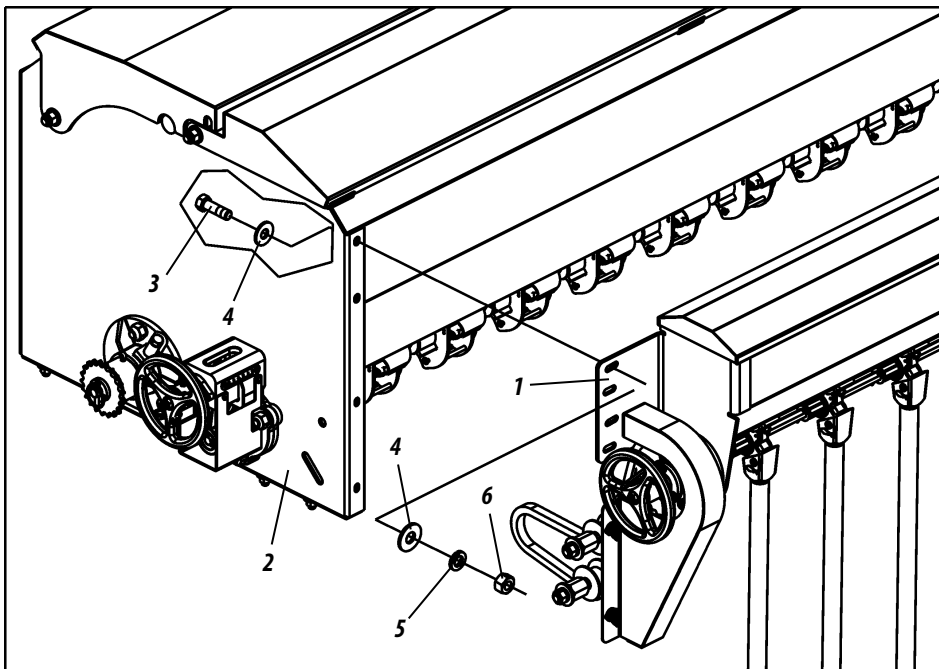

- 2- Then, put the chain (7) in the gear (8) of the fertilizer tank.

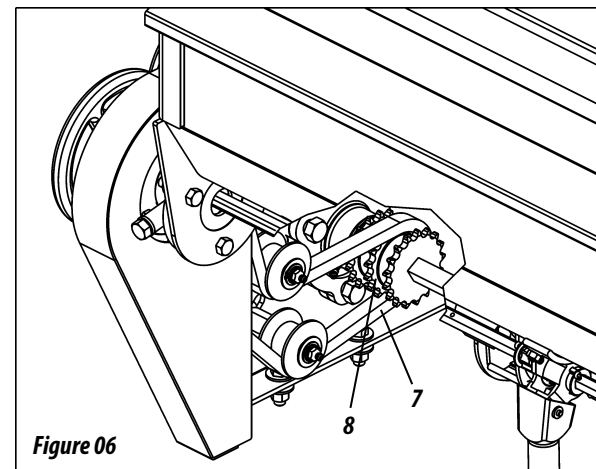

Figure 06

- 3- Finally, introduce the hose (9) in the fine seed box (1) inside the cup (10) of the fertilizer tank (2).

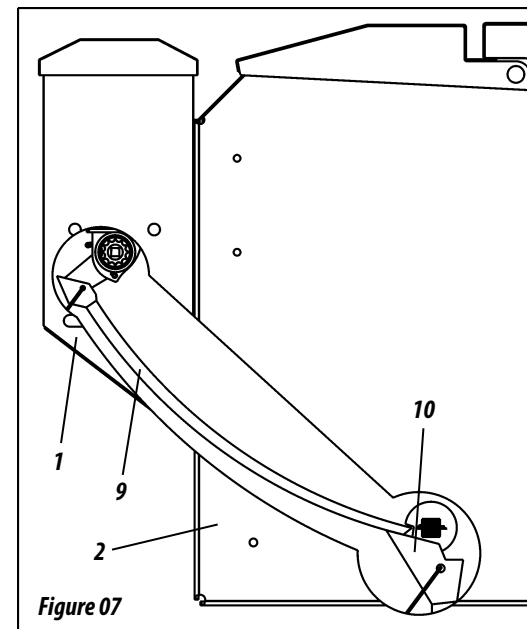

Figure 07

### **IMPORTANT**

*Before start working with the planter, make a general review, making sure that all components are properly assembled.*

## 05 - TRACTOR COUPLER

### DRAG COUPLER (FIGURE 08) SAB 2000 / 2300 / 2600 / 3000

Before connecting the planter to the tractor, check if the tractor is equipped with the set of weights on the front or front wheels to keep it down. The rear wheels will give the tractor higher stability and traction to the ground:

To couple the planter, do the following:

- 1- Level the coupling header (1) in relation to the tractor coupling through the regulator (2). Then, slowly close the seeder to the tractor in reverse gear, being aware to applying the brakes.
- 2- Couple the planter to the tractor by fixing it with the hitch pin (3) and lock (4).
- 3- Connect the hoses (5) in the quick tractor coupler, as shown in figure 08.

Figure 08

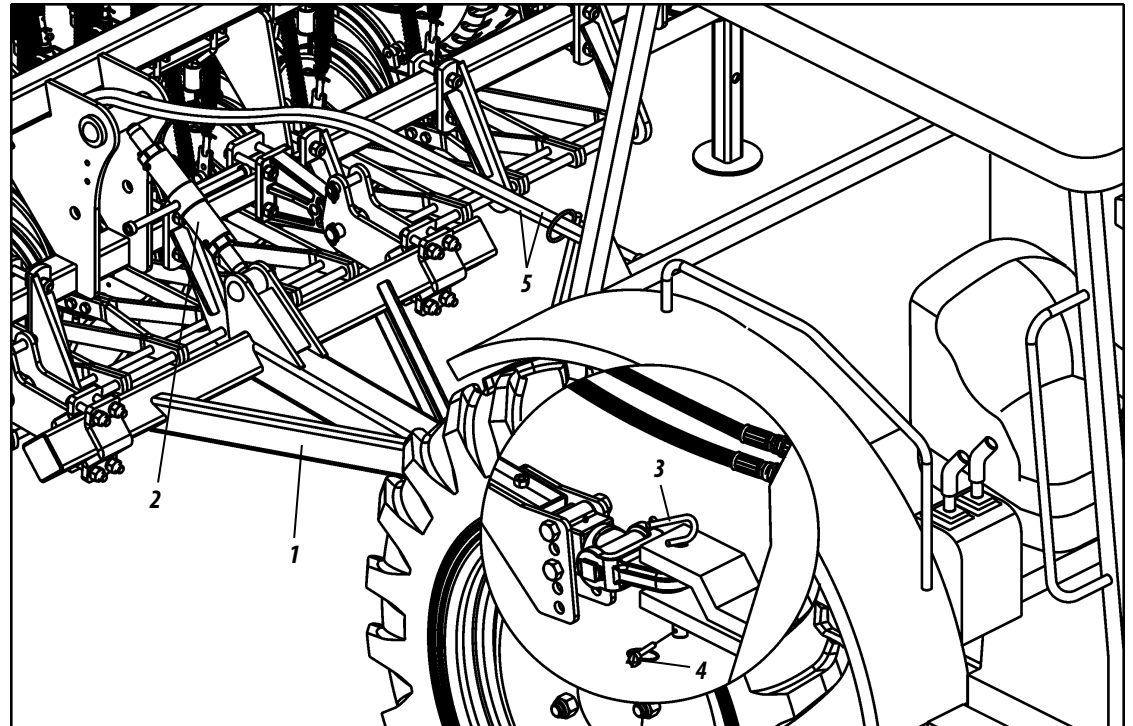

### **IMPORTANT**

*By coupling the planter, find a safe and accessible place, and always use reduced gear with low acceleration.*

### **ATTENTION**

*Before connecting or disconnecting the hydraulic hoses, shut off the engine and relieve the hydraulic system pressure by fully activating the command levers. When relieving the system pressure, make sure that there is no one near the area of equipment movement.*

## HYDRAULIC COUPLER (FIGURE 09) SHB 2000 / 2300 / 2600 / 3000

Before connecting the planter to the tractor, make sure the tractor is ready to work by observing the following items:

- 1- Check if the tractor is equipped with the set of weights on the front or front wheels to keep it down. The rear wheels will give the tractor higher stability and traction to the ground.
- 2- Adjust the ring of the tractor's lower arms.

To couple the planter, do the following:

- 3- Slowly bring the tractor near the planter in reverse gear, being ready for applying the brakes. Use the lever that controls the hydraulic position when approaching the planter, leaving the lower left arm (1) at the level of the coupling point.
- 4- Couple the lower left arm (1) of the tractor to the planter, locking it with the hitch pin (2) and lock w / the lock ring (3).
- 5- Then, couple the regulator (4) at the 3rd point of the planter through the pin (5) and lock with the lock w / ring (6).
- 6- Finally, couple the lower right arm (7) which has up and down movements using the leveling handle (8). In this movement, the extensor thread of the tractor's upper arm 3rd point can be used to approximate or withdraw the planter, thus facilitating the coupling.

Figure 09

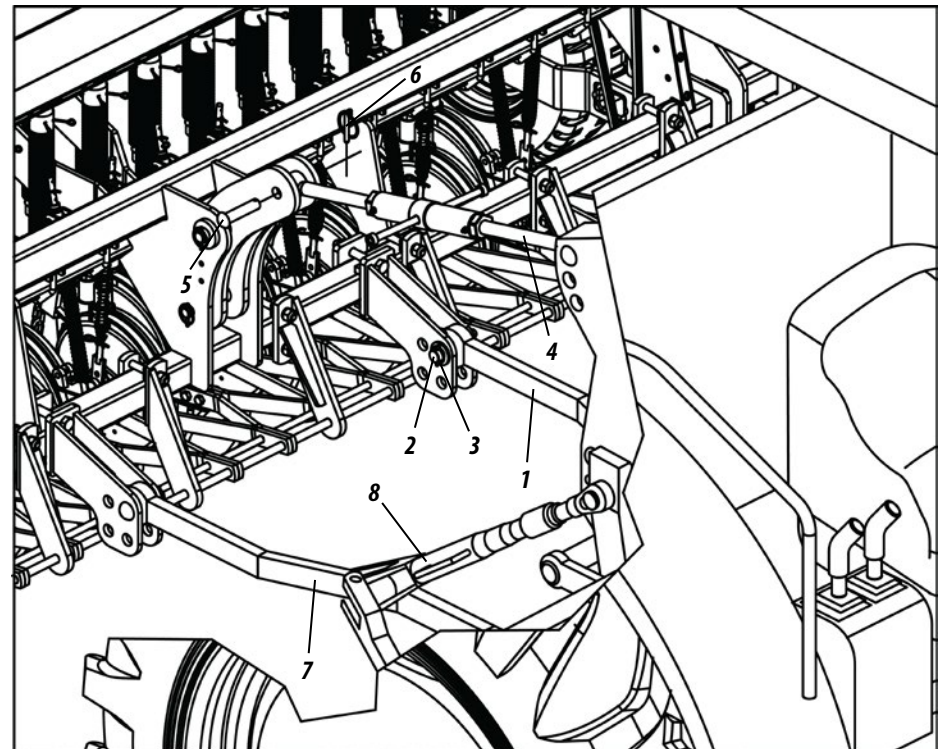

### **ATTENTION**

*When coupling the planter, find a safe and accessible place, always use low gear with low acceleration. Make sure to relieve the hydraulic tractor and that no one is near the area of movement of the equipment.*

## WORK / TRANSPORTATION (FIGURES 10/11/12/13) SAB 2000 / 2300 / 2600 / 3000

Before working or moving the planter, do the following:

- 1- Retract the support bracket (1) and fix it with the pin (2) and lock (3).

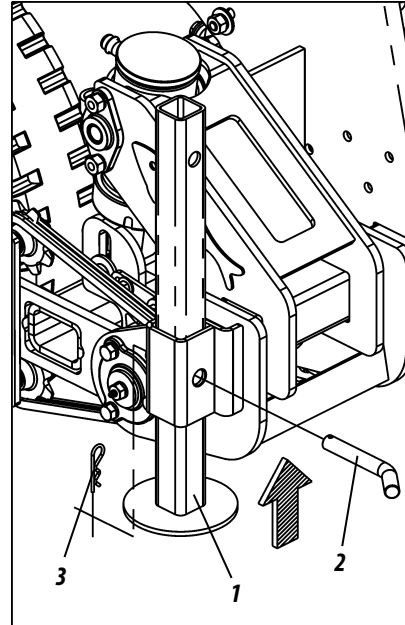

Figure 10

- 2- With the planter lowered, make sure it is leveled in relation to the ground, otherwise, level it through the header regulator (4).

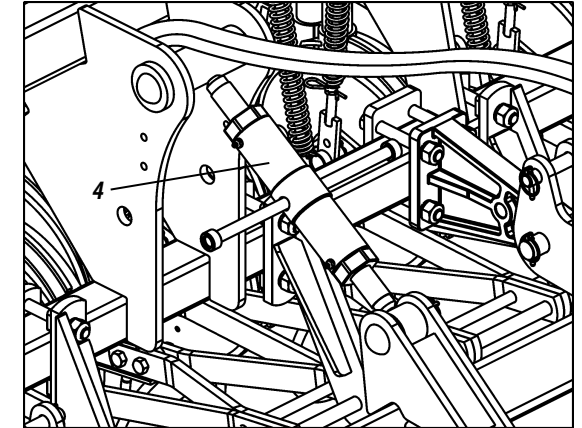

Figure 11

- 3- Then, lift lines by pushing the total triggering of the hydraulic cylinder and put the lock (5) on the piston rod (6) locking with the pin (7) and lock (8).

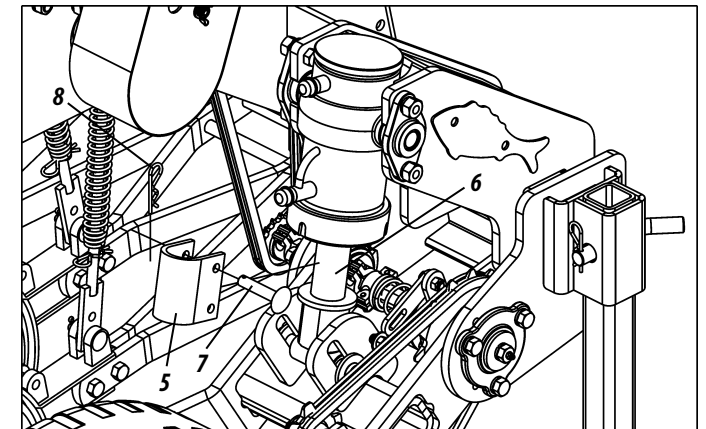

Figure 12

### IMPORTANT

*Do not transport the planter if it is loaded, since it may damage the equipment. Supplying it only at the workplace. If the planter is to remain on the field for any reason, we recommend covering it with impermeable canvas tarpaulin to prevent moisture.*

- 4- Finally, articulate the ladder (9), locking it in the raised position not to touch the ground at the time of working or transport, as shown in Figure 13.



## ATTENTION

*Do not work / transport the seeder without checking all the procedures above.*

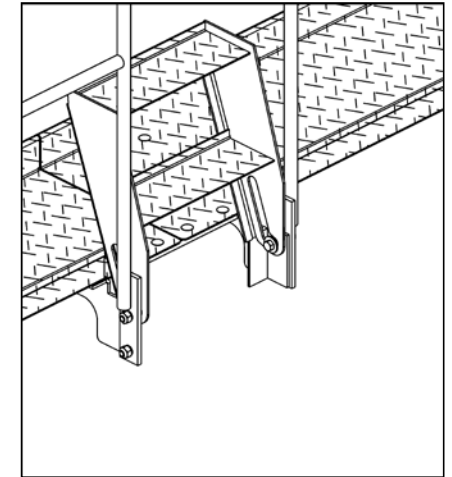
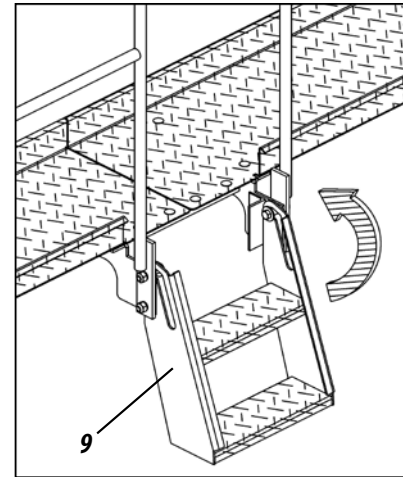

Figures 13

## WORK / TRANSPORTATION (FIGURES 14/15) SHB 2000 / 2300 / 2600 / 3000

Before working or moving the planter, do the following:

- 1- Retract the support bracket (1) and fix it with the pin (2) and lock (3).

Figure 14

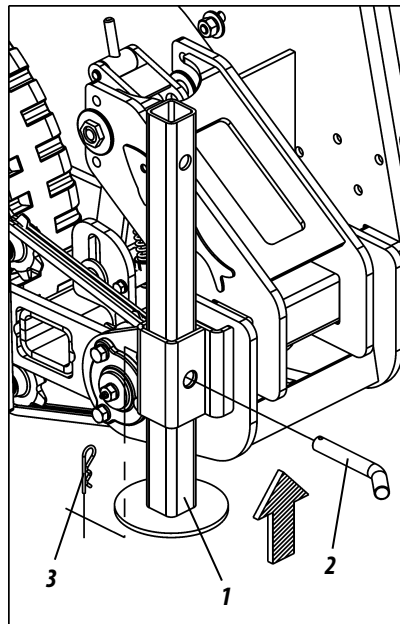

## IMPORTANT

*Before working or moving the planter, do the following:*



## ATTENTION

*Do not work / transport the planter without checking all the procedures above.*

- 2- Then, use the ladder (9), locking it in the raised position not to touch the ground at the time of work or transport, as shown in the figure 15.

Figures 15

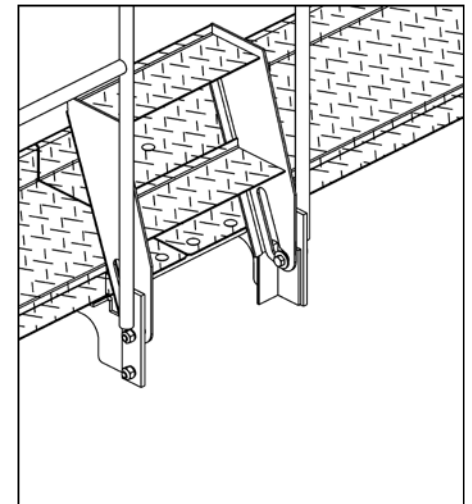
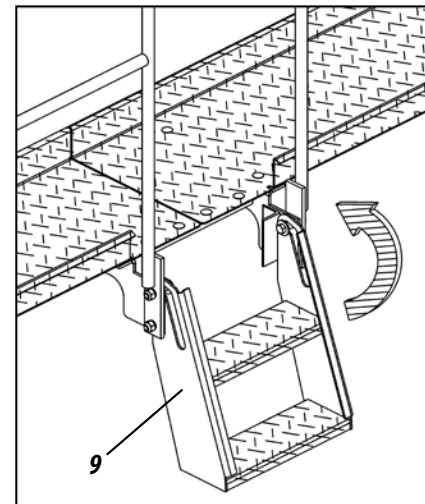

## 06 - ADJUSTMENTS

### CENTRALIZING THE SHB PLANTER (FIGURE 16) SHB 2000 / 2300 / 2600 / 3000

To centralize the SHB planter in relation to the longitudinal axis of the tractor, proceed as follows:

- 1- Align the upper couple of the planter to the 3rd point of the tractor, checking if the distance "E" of the lower hydraulic arms is equal in relation to the tires of the tractor. The lower arms must be leveled with each other.

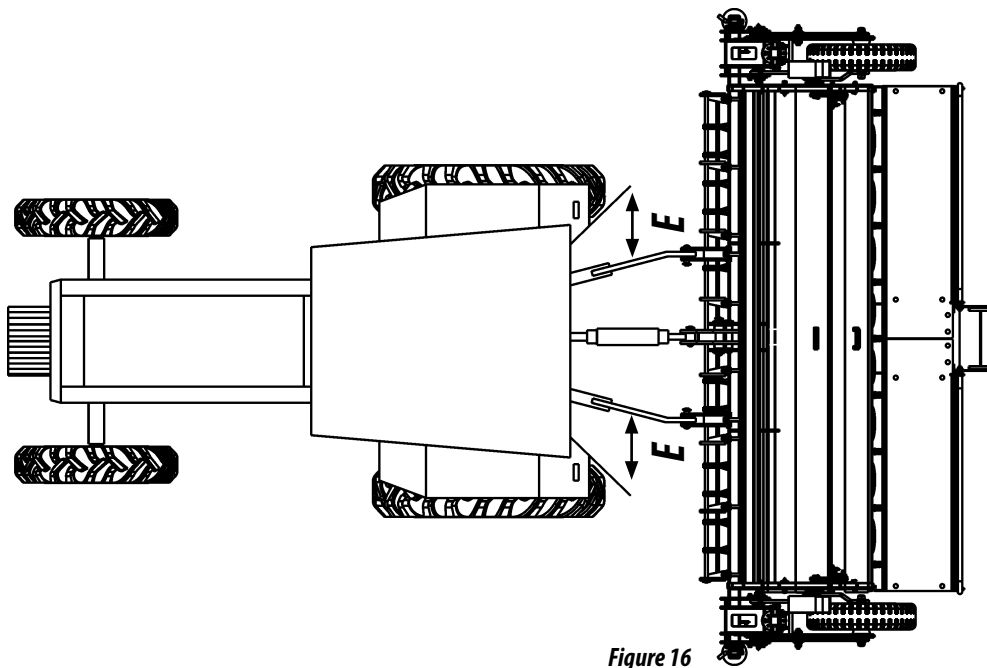

Figure 16

### LEVELING OF THE SHB PLANTER (FIGURE 17) SHB 2000 / 2300 / 2600 / 3000

To level the SHB planter, proceed as follows:

- 1- The tractor must be on a flat place, then level the planter in transverse order (width) by the crank of the hydraulic coupling right lower arm. Observe the "a" measures that must be equal.
- 2- The longitudinal leveling (length) is done through the arm at the 3rd point (1). Note that the lines should be parallel to the ground.

Figure 17

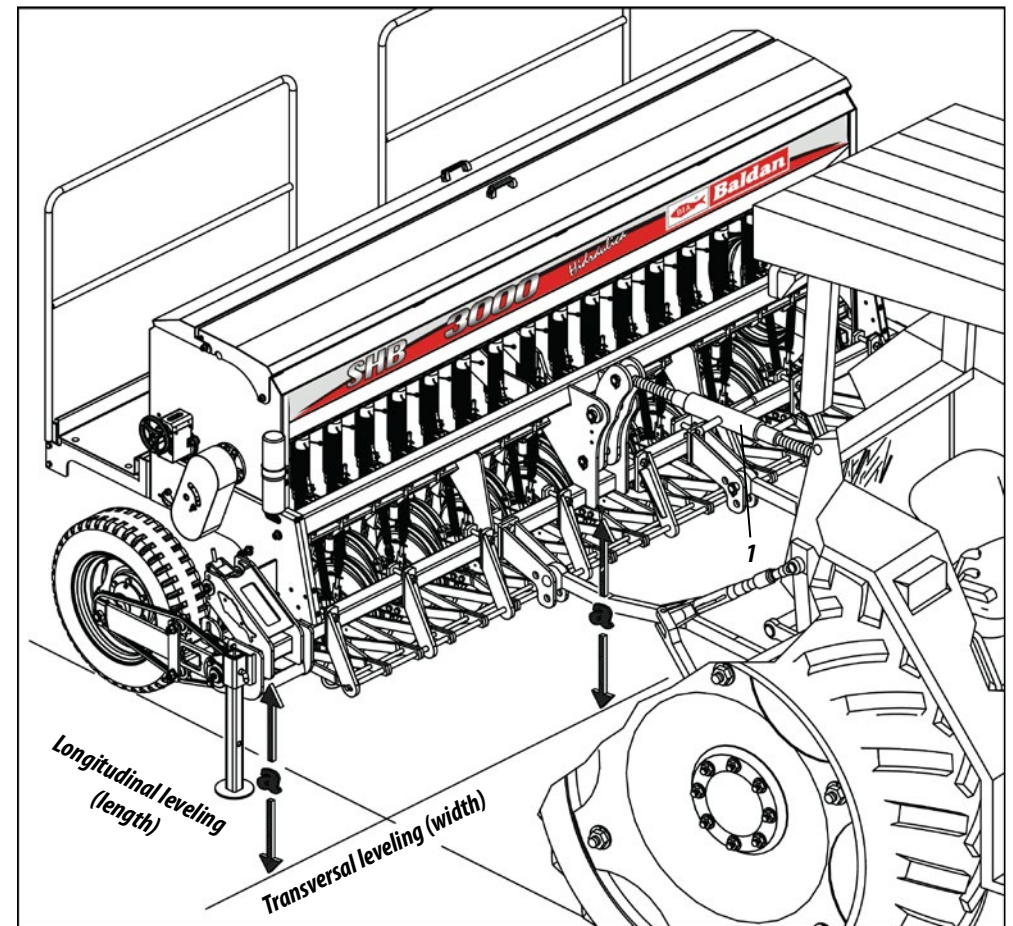

## ADJUSTMENT OF SHB TIRE PRESSURE (FIGURES 18) SHB 2000 / 2300 / 2600 / 3000

When the wheel set (1) of the SHB planter is dragging on the ground, raise the pressure of the spring rod (2). To increase pressure on the spring rod, proceed as follows:

- 1- First, lift the tractor hydraulic by suspending the SHB.
- 2- Then, loosen the screw (3), lift the fixation sleeve (4) in order to pressure the spring (2).
- 3- Then, tighten the screw (3) locking the spring (2).

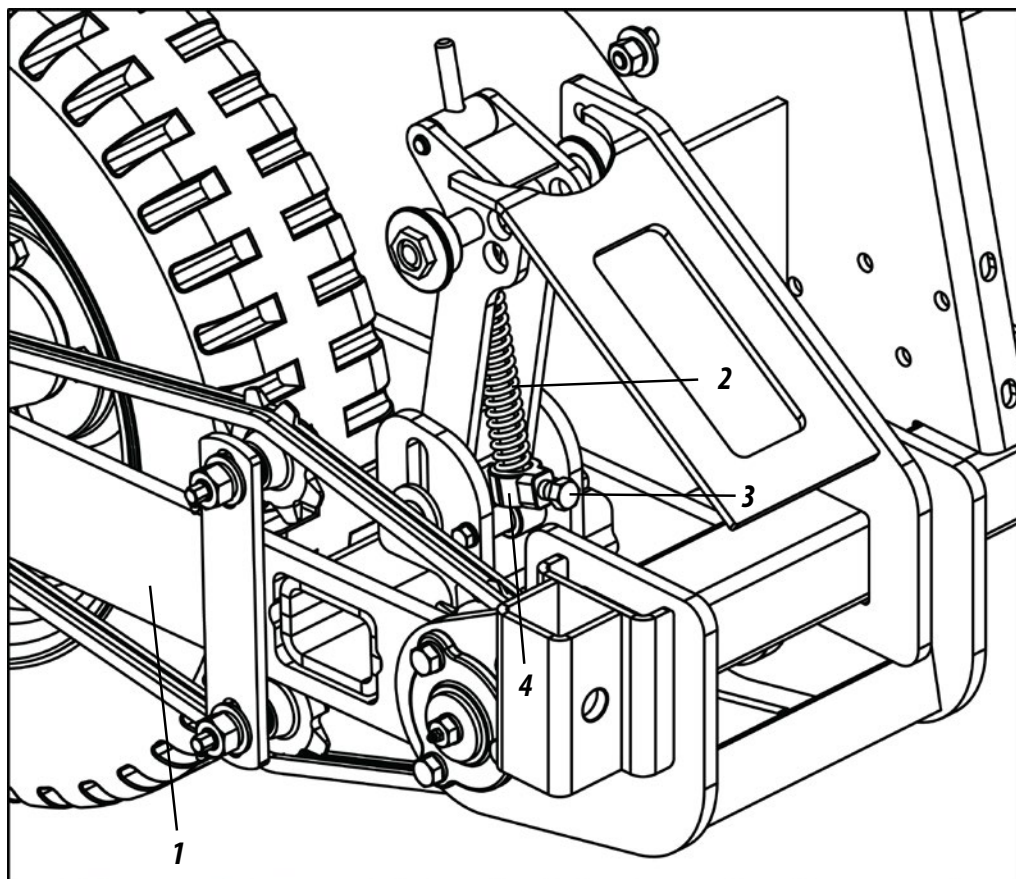

**LOWER SPRING PRESSURE**

*Lower adhesion of the tire to the ground*

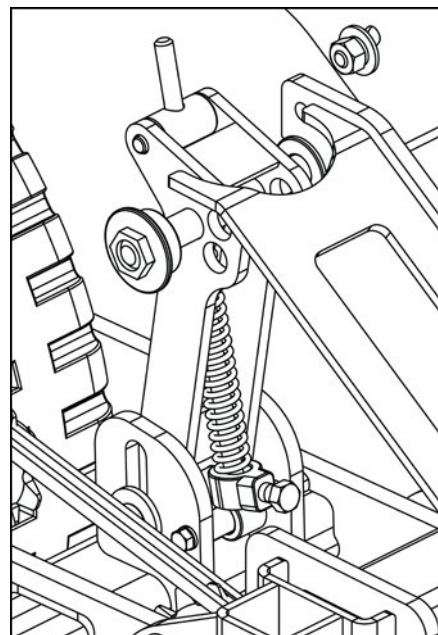

**ATTENTION**

*When performing pressure regulation in the spring rod, make this adjustment in both side of the planter.*

**HIGHER SPRING PRESSURE**

*Greater adhesion of the tire to the ground*

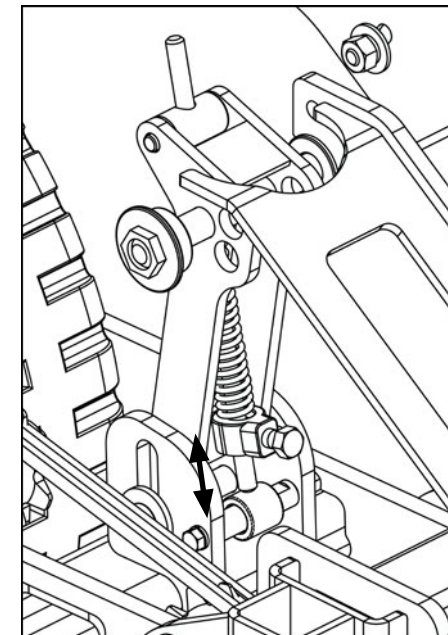

**IMPORTANT**

*This adjustment that gives higher or lower pressure in the spring rod, must be made according to working conditions.*

*Figures 18*

## ADJUSTMENTS OF THE SHB WHEEL SET (FIGURES 19 / TABLE 02)

### SHB 2000 / 2300 / 2600 / 3000

For higher penetration of the lines on the ground, the wheel set (1) has several adjustments (2) which help the operator to achieve the desired working depth. To adjust the SHB wheel set, proceed as follows:

- 1- Loosen the screw (3), pressure washer (4) and flat washer (5), remove the pin (6) and place it in another hole according to the depth you want to achieve.

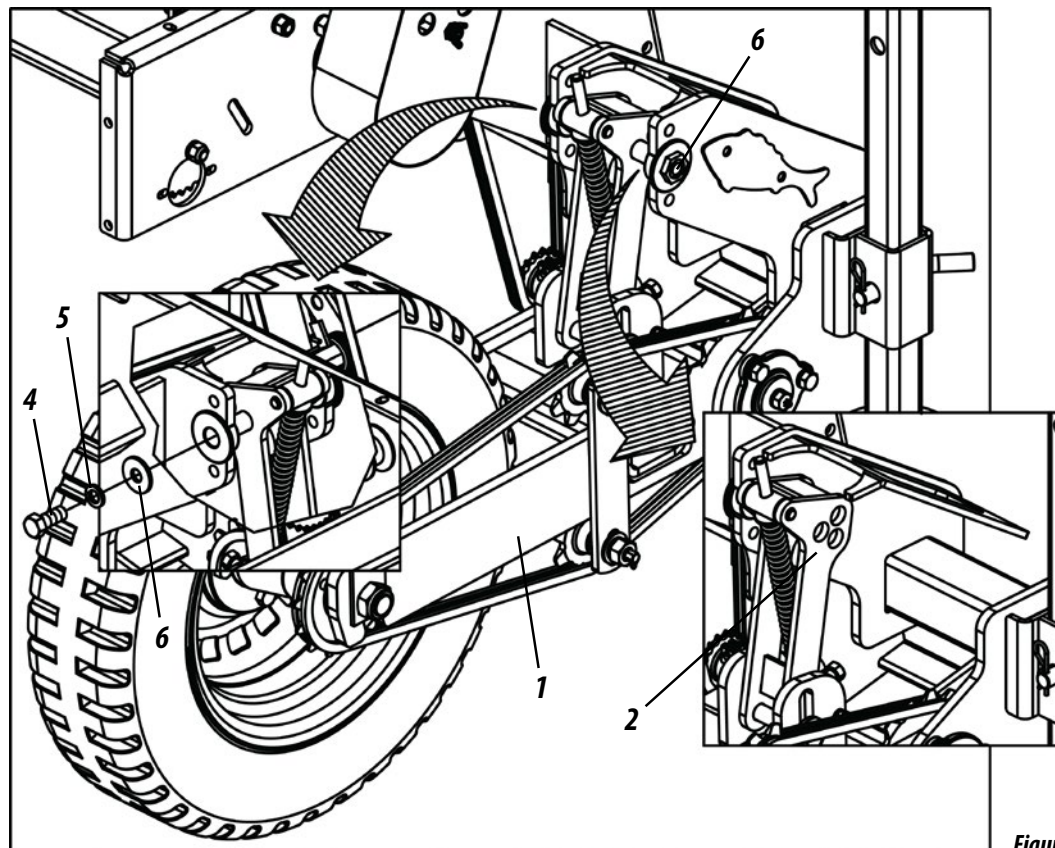

Figures 19

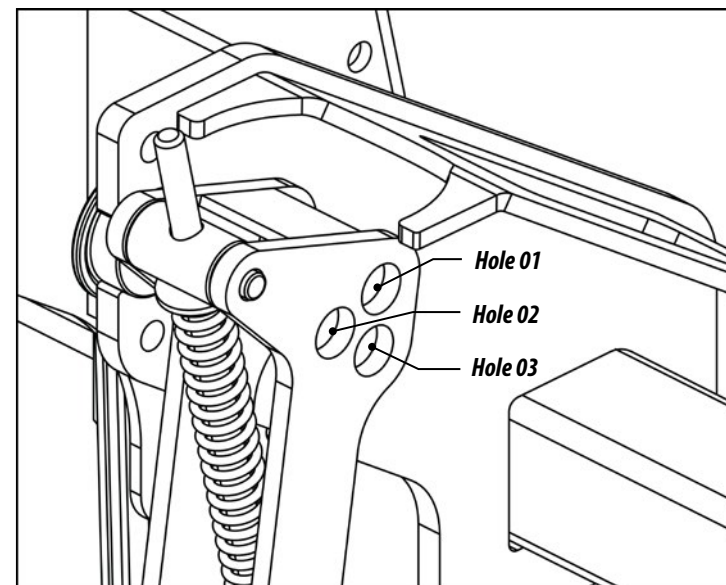

Figures 19

Table 02

WHEEL SET ADJUSTMENTS	
Adjustments	Depth
Hole 01	10 mm
Hole 02	40 mm
Hole 03	80 mm

**ATTENTION**

*Before making any adjustment in the cutting discs, furrow openers and double discs of fertilizer and seed, make the adjustment of the wheel set, on both sides, because this adjustment interferes with the depth of discs.*

## 07 - SEED DISTRIBUTION

### SEED ADJUSTMENT (FIGURES 20 / TABLE 03) SAB / SHB 2000 / 2300 / 2600 / 3000

- 1- Adjust the gauge of the seed distribution boxes for each type of seed and to avoid it from breaking or causing an irregular seeding.
- 2- The amount of seed is regulated by the steering wheel (1).
- 3- Adjust the regulation pin (2) according to the size of each type of seed to be used.

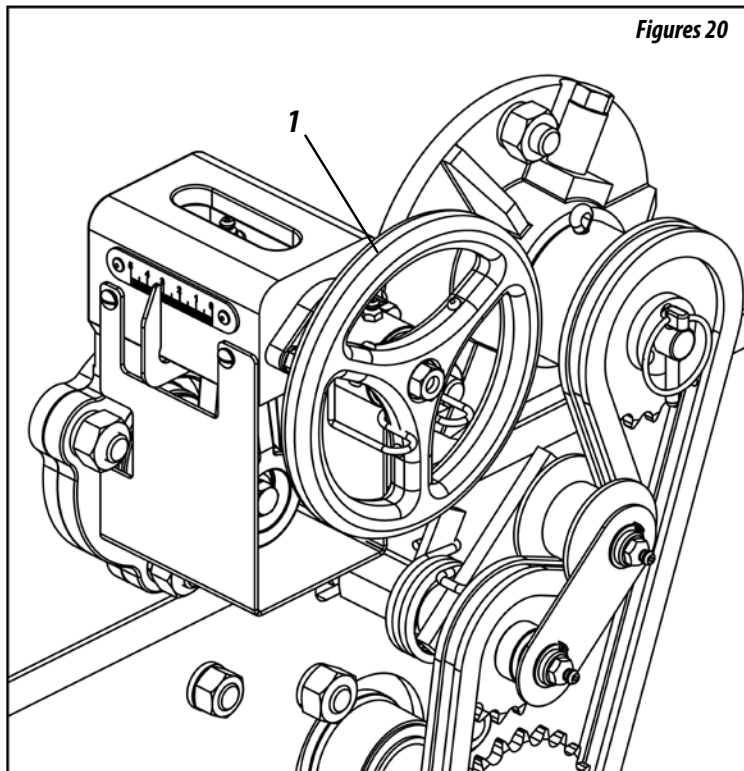

Figures 20

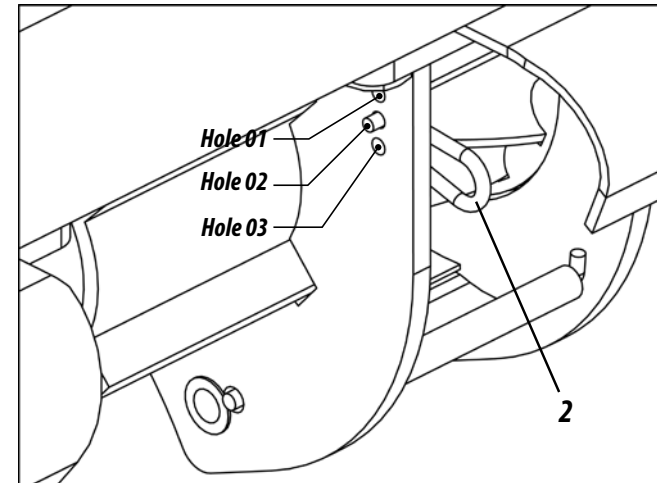

Figures 20

According to the various types of seeds and crops, the following adjustments are usually recommended:

Table 03

<b>HOLE 01</b>
Place the regulation pin (2) in the hole (1) of the seed distributor to plant: <b>Wheat, Sorghum, Barley, Oats, Rye and similar seeds.</b>
<b>HOLE 02</b>
Place the regulation pin (2) in the hole (2) of the seed distributor to plant: <b>Sorghum, Soybeans, Oats and similar seeds.</b>
<b>HOLE 03</b>
Place the regulation pin (2) in the hole (3) of the seed distributor to plant: <b>Rice, oats, peas and similar seeds.</b>

**ATTENTION**

Before start planting, check if the seed distribution is correct regarding the distribution table on the next page.

**TABLE FOR SEED DISTRIBUTION (FIGURES 21 / TABLE 04)**  
**SAB / SHB 2000 / 2300 / 2600 / 3000**

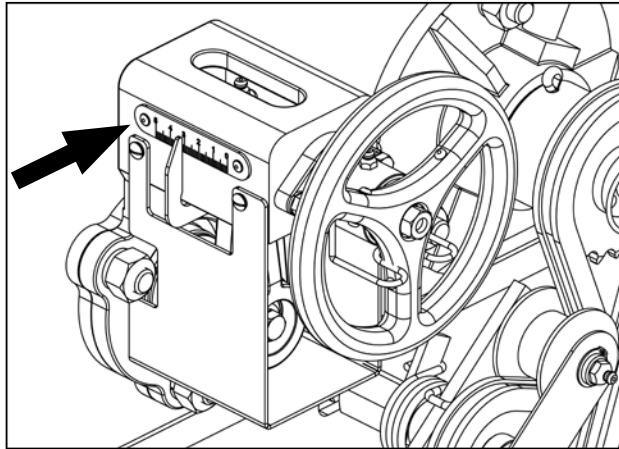

Figures 21

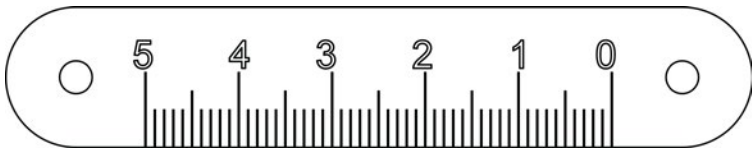

Results in grams for 50 meter lines

**Seed Distributor**

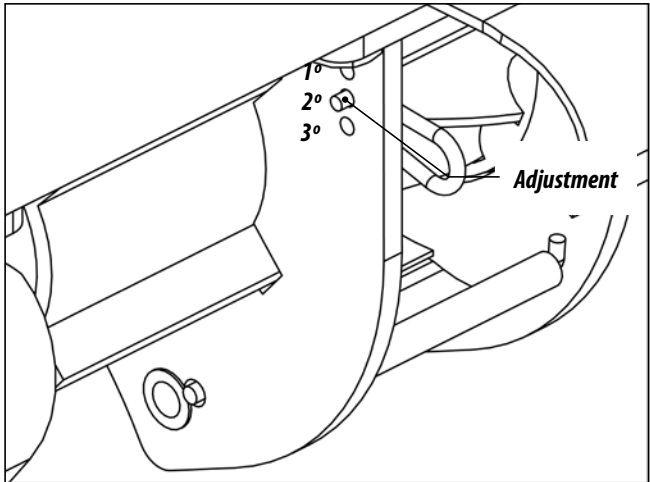

Figures 21

**Ha = 10.000m<sup>2</sup>**  
**AA = 24.200m<sup>2</sup>**

To calculate the amount of fertilizer and seed per hectare or AA, you must:

- A - Have knowledge about the amount of fertilizer or seed to be applied by (Ha) or (AA).
- B - Be aware of the spacing between lines of the planter.
- C - Perform the calculation by Ha, dividing Ha = 10,000 m<sup>2</sup> by the spacing to be planted.
- D - If the calculation is made by AA, divide AA = 24,200 m<sup>2</sup> by the spacing to be planted.
- E - Finally, divide the amount of fertilizer and seed to be applied by linear meters.
- F - To measure the weight, collect the fertilizer or seed in 10 or more meters make the weighing.

**Seed Dosing Scale**

Table 04

	0	5	10	15	20	25	30	35	40	45	50
1	-	14	28	43	59	76	94	111	128	146	164
2	-	15	31	48	66	85	105	123	143	162	182
3	-	17	34	53	73	94	116	137	158	180	202
1	-	21	44	71	101	136	173	204	235	267	299
2	-	25	53	86	123	164	209	246	284	323	362
3	-	29	61	99	142	190	243	286	330	374	420

**RICE**  
 1590 grains per 50 grams

**WHEAT**  
 1020 grains per 50 grams

## ADJUSTMENT OF THE FINE SEED BOX - OPTIONAL (FIGURES 22 / TABLE 05) SAB / SHB 2000 / 2300 / 2600 / 3000

To regulate the distribution of the fine seed box, proceed as follows:

- 1- See the distribution table below and check the amount desired by hectare.
- 2- Then, unlock the steering wheel (1) through the latch (2).

Table 05

<b>DISTRIBUTION OF PASTURE SEEDS (kg / ha) WITH SPACING OF 170 MM</b>									
		SCALE NUMBER							
TYPE OF CULTURE		0,5	1,0	1,5	2,0	2,5	3,0	3,5	4,0
GRASSES	GUINEA GRASS	-	2,0	3,5	5,0	9,0	10,0	10,0	11,0
	COMMON BRACHIARIA	-	5,0	7,0	10,0	17,0	20,0	20,0	22,0
	BRACHIARA BRIZANTHA	-	3,0	5,0	7,0	14,0	17,0	17,0	20,0
	MILLET	3,0	8,0	14,0	20,0	32,0	40,0	40,0	48,0
LEGUMES	PERENNIAL SOYBEAN	3,5	10,0	17,0	24,0	32,0	41,0	50,0	59,0
	ALFALFA	4,0	12,0	20,0	29,0	38,0	47,0	56,0	65,0
	DEERWEED	4,5	13,0	21,0	30,0	40,0	50,0	60,0	70,0
	DESMODIUM	3,8	12,0	19,0	26,0	34,0	43,0	52,0	61,0
	CLOVER	3,6	11,0	18,0	25,0	33,0	42,0	51,0	60,0

- 3- Then, turn the steering wheel (1) to "A" or "B" adjusting the scale (3) to the value found in the table according to your need and working condition.

**EXAMPLE:** To distribute 10 kg/ha of "guinea grass" seed with spacing of 170 mm, turn the steering wheel (1) until the controller reaches the number 3.5 on the scale (3) as figure.

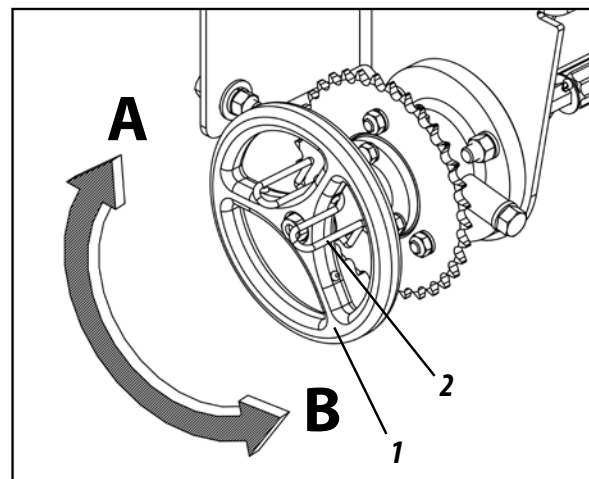

**Turning the steering wheel to "A"**  
The scale closes

**Turning the steering wheel to "B"**  
The scale opens

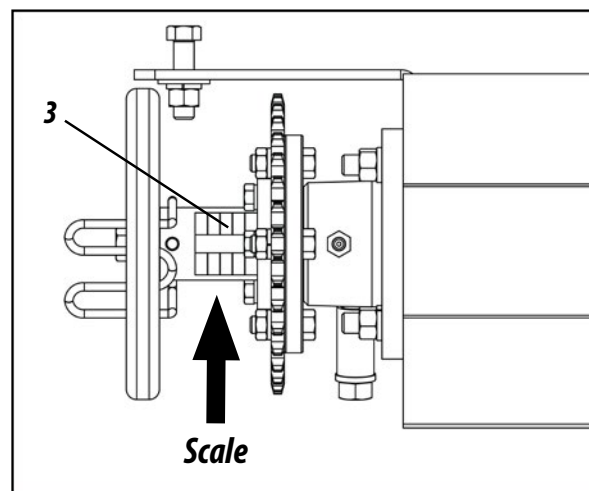

Figures 22

**ATTENTION**

The seed distribution table above shows approximate distribution values per hectare with 170 mm spacing. This table may vary according to different varieties of seeds. Practical checking should be performed before you start planting.

## 08 - FERTILIZER DISTRIBUTION SYSTEM

### METALLIC FERTILIZER TANK (FIGURES 23) SAB / SHB 2000 / 2300 / 2600 / 3000

The floating spiral fertilizer distribution system consists of a shaft arranged at the bottom of the fertilizer tank that when it starts turning, the fertilizer involves the shaft, which distributes it, avoiding the use of intermediate bearings.

In determining the number of lines and desired spacing, do the following :

- 1- Connect the hose (1) to the distributor outputs (2) through the strap (3), making the connection of hoses (1) so that they do not fold or bend.
- 2- The outputs of the fertilizer tank that will not be used should be closed with covers (4) into the tank and with the cap (5) through the strap (6) in external outputs; this will prevent fine fertilizer particles to fall on the planter.

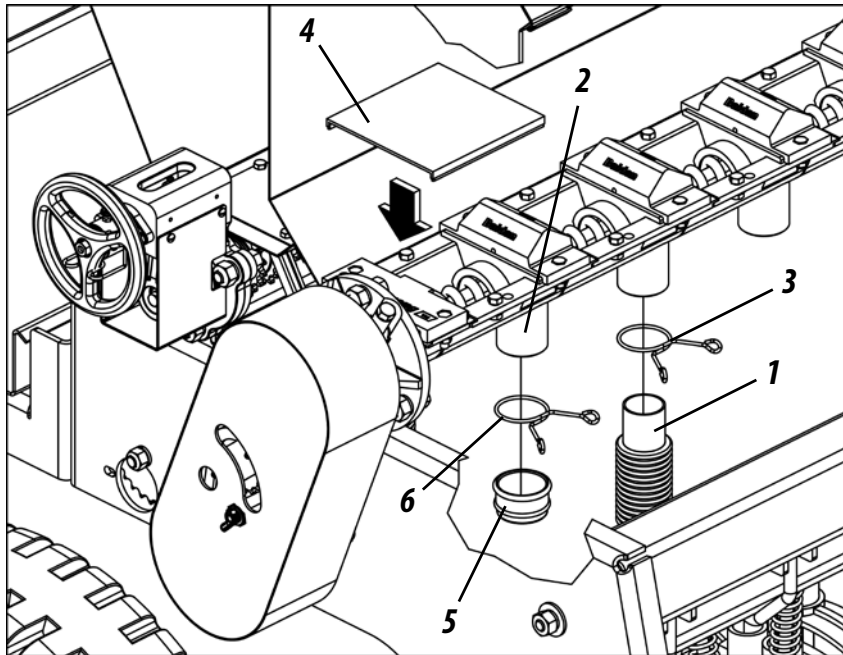

Figures 23

- 3- The floating spiral fertilizer dosing system has safety outputs that upon filling the fertilizer in the dispenser and the hose is clogged, it will start leaking fertilizer by these safety outputs, ensuring that the system will operate without any damage. If this occurs, proceed the cleaning of the feeder up to the end of the hose near the furrow rod or double disc, because the system can clog due to roots, pieces of plastic and other objects.

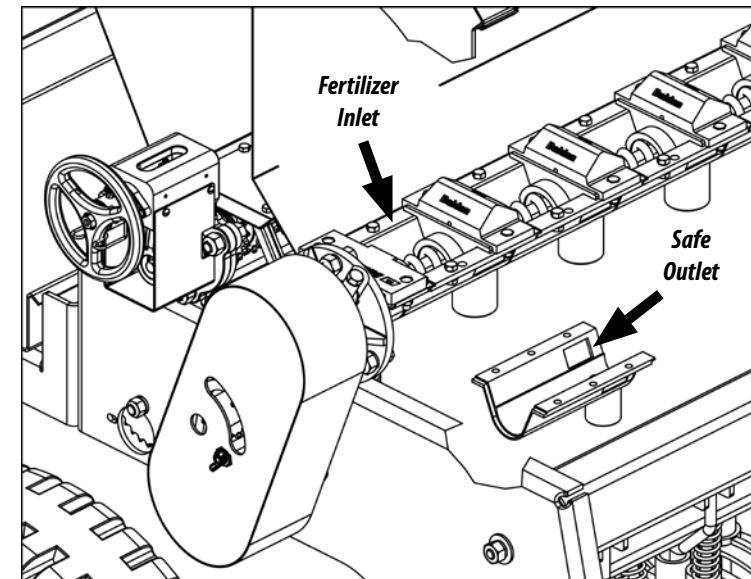

Figures 23

### IMPORTANT

*Check daily distributors and hoses, if necessary, and clean the outputs thereof. When the fertilizer has impurities or is wet, do the cleaning more often.*

TABLE OF FERTILIZER DISTRIBUTION PER LINEAR METER - SAB / SHB

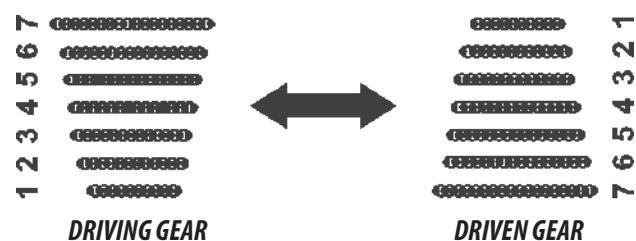

GEAR	TEETH
1	17
2	19
3	21
4	23
5	25
6	27
7	29

DRIVING GEAR	DRIVEN GEAR	GRAMS 50 METERS	KG / HECTARE	DRIVING GEAR	DRIVEN GEAR	GRAMS 50 METERS	KG / HECTARE
1	7	88	104	4	3	164	193
1	6	95	111	4	2	182	214
1	5	102	120	4	1	204	240
1	4	111	131	5	7	130	153
1	3	122	143	5	6	139	164
1	2	135	158	5	4	164	192
2	7	99	116	5	3	179	211
2	6	106	125	5	2	198	233
2	5	114	135	5	1	221	260
2	4	124	146	6	7	140	165
2	3	136	160	6	5	163	191
2	1	168	198	6	4	177	208
3	7	109	128	6	3	194	228
3	6	117	138	6	2	214	252
3	5	126	149	6	1	239	281
3	4	137	162	7	6	162	190
3	2	166	196	7	5	175	205
3	1	186	219	7	4	190	223
4	7	119	140	7	3	208	245
4	6	128	151	7	2	230	270
4	5	138	163	7	1	257	302

## 09 - PRACTICAL CALCULATION FOR FERTILIZER DISTRIBUTION

- 1- Determine the spacing between lines and the amount of fertilizer to be distributed by Bushel (Aa) or Hectare (Ha).
- 2- **Example:** Seeder with spacing of 170 mm, to distribute 500 Kg of fertilizer per hectare, use the formula below:

Equation:

$$X = \frac{E \times Q}{A} \times D$$

### Formula data:

- E** = Spacing between lines (mm)
- Q** = Amount of fertilizer to be distributed [kg]
- A** = Area to be fertilized [m<sup>2</sup>]
- D** = Distance of 50 meters (test)
- X** = Grams of fertilizer in 50 meters

Model:

$$X = \frac{170 \times 500}{10.000} \times 50$$

$$X = 8.50 \times 50 = 425$$

$$X = 425 \text{ grams in 50 meters per line}$$

## PRACTICAL TEST FOR MEASURING THE AMOUNT OF FERTILIZER AND SEED DISTRIBUTION

- 1- To more precise distribution of both seeds and fertilizer, perform the test of the amount to be distributed on the planting site because for each land, there is a specific condition.
- 2- Check and keep the tires in adequate calibration.
- 3- Find the test distance in the table, we have selected 50 linear meters.
- 4- Fill the seed tanks at least halfway. Run some meters outside the testing area, so that the seeds and fertilizer fill the dosimeters.
- 5- Seal the seed spout outlets and place containers for collection in the fertilizer outputs. Move the tractor in the testing area, always at the same speed that will be used in planting, from 10 to 12 km / h.
- 6- After running the delimited space (fertilizer table) in the column (grams per line in 50 meters), remove the sealing of the seed spout and collect them for counting and weighing of the fertilizer collected. If it is necessary to increase or decrease the amount of fertilizer and seed, refer to the table.

### IMPORTANT

*A field test should be conducted in the distribution of seed and fertilizer over 50 meters to subsequently compare the seed and fertilizer results.*

# 10 - STIRRING SYSTEM

## SEED STIRRING SYSTEM - OPTIONAL (FIGURE 24) SAB / SHB 2000 / 2300 / 2600 / 3000

The stirring system (optional) is used for seeds, aiding in the seed removal and flow. The stirring system consists of the following components:

- 1 - Full stirring shaft
- 2 - Full stirring shaft support
- 3 - Full Transmission System

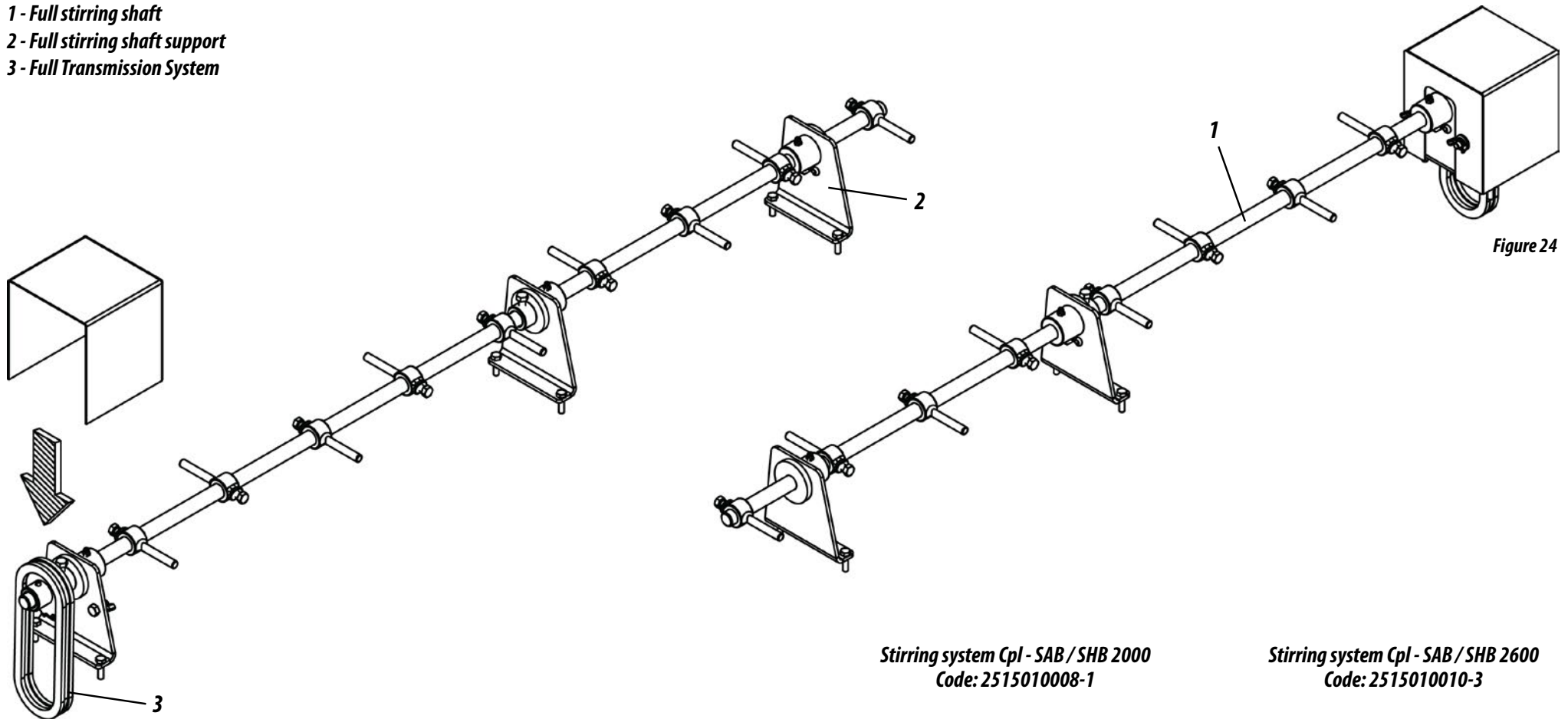

Figure 24

Stirring system Cpl - SAB / SHB 2000  
Code: 2515010008-1

Stirring system Cpl - SAB / SHB 2600  
Code: 2515010010-3

Stirring system Cpl - SAB / SHB 2300  
Code: 2515010009-0

Stirring system Cpl - SAB / SHB 3000  
Code: 2515010011-1

11 - PLANTING LINES

MODELS OF LINES (FIGURES 25)  
SAB / SHB 2000/2300/2600/3000

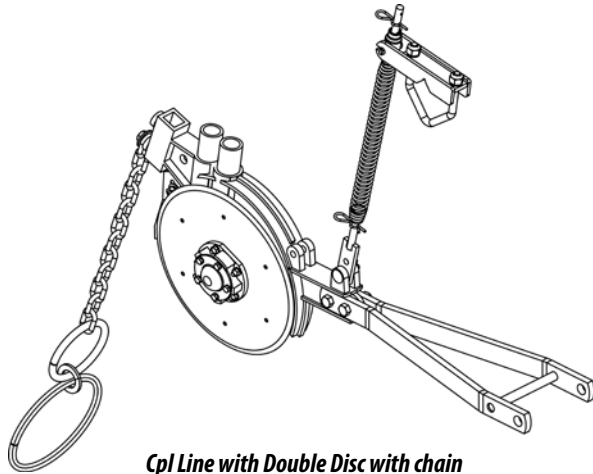

*Cpl Line with Double Disc with chain*  
Code: 2517011507-7

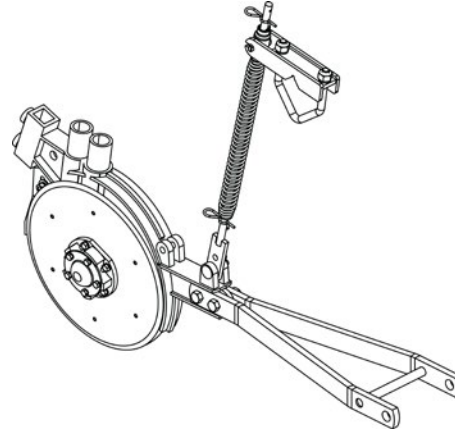

*Cpl Line with Double Disc without chain*  
Code: 5124010570-9

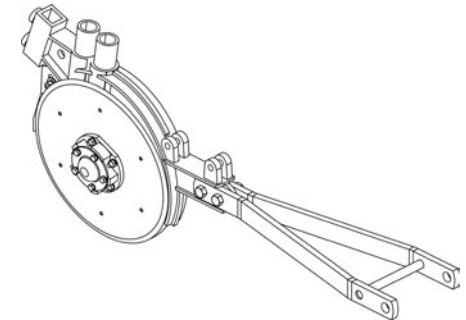

*Major Mounted Cart*  
Code: 5124010571-7

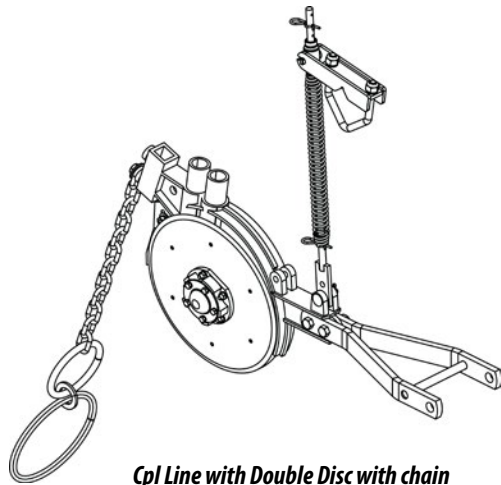

*Cpl Line with Double Disc with chain*  
Code: 2517011506-9

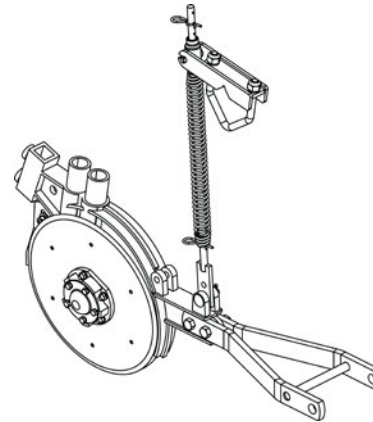

*Cpl Line with Double Disc without chain*  
Code: 5124010568-7

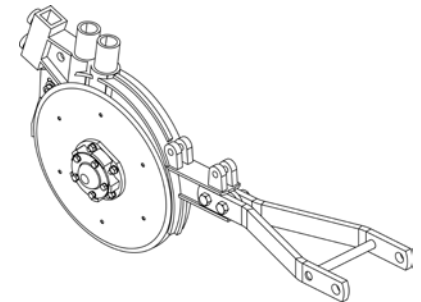

*Minor Cart Mounted*  
Code: 5124010569-5

Figures 25

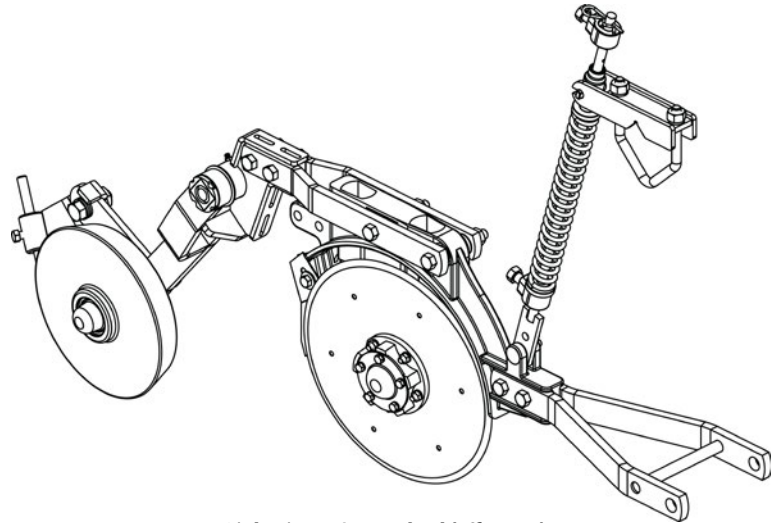

*Lower Right Line w / Iron Wheel (off center)*  
Code: 2517011740-1

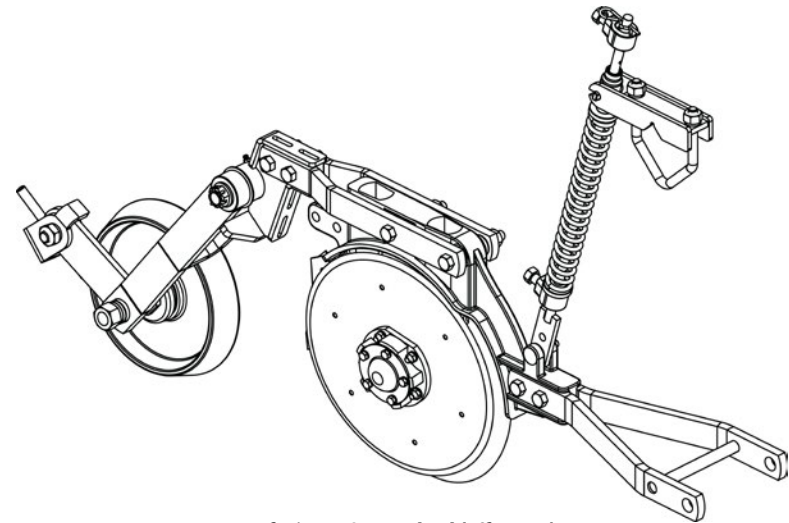

*Lower Left Line w / Iron Wheel (off center)*  
Code: 2517011741-0

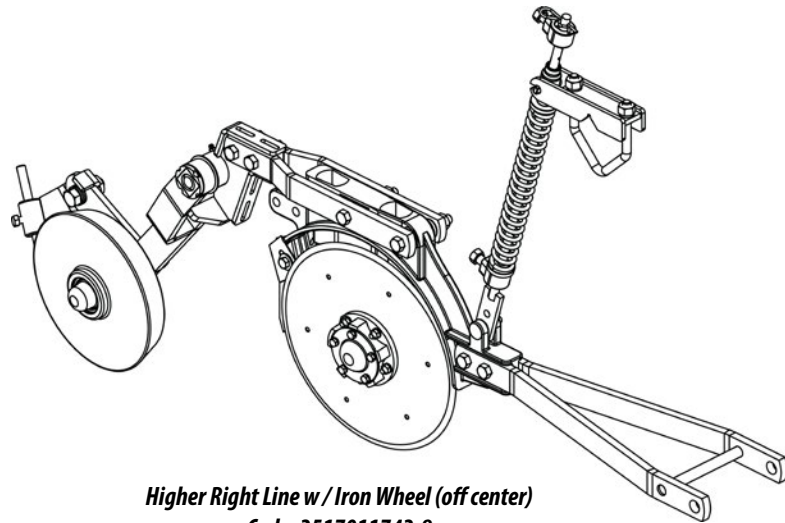

*Higher Right Line w / Iron Wheel (off center)*  
Code: 2517011742-8

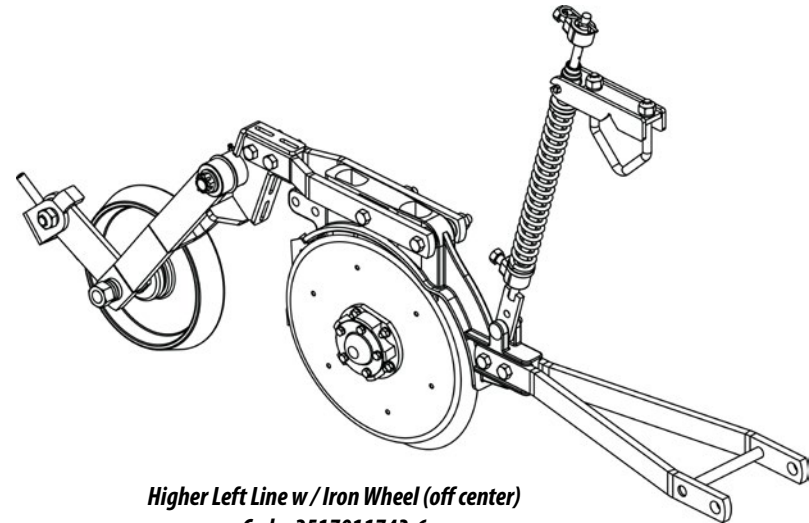

*Higher Left Line w / Iron Wheel (off center)*  
Code: 2517011743-6

Figures 25

## MODELS OF OPTIONAL WHEELS (FIGURES 26) SAB / SHB 2000 / 2300 / 2600 / 3000

Planters models SAB and SHB have options that may be acquired in accordance with the need of work. Compaction wheels are among the options available in 6 different models:

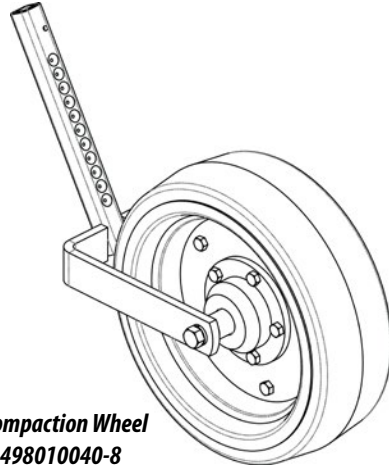

*Smooth Compaction Wheel*  
Code: 5498010040-8

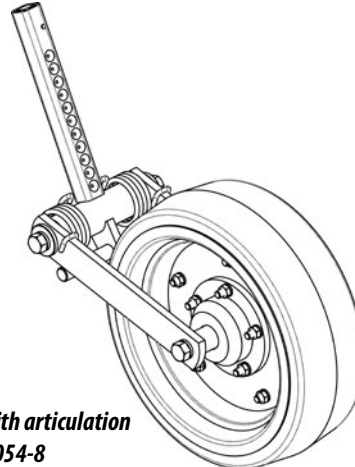

*Flat compaction wheel with articulation*  
Code: 5498010054-8

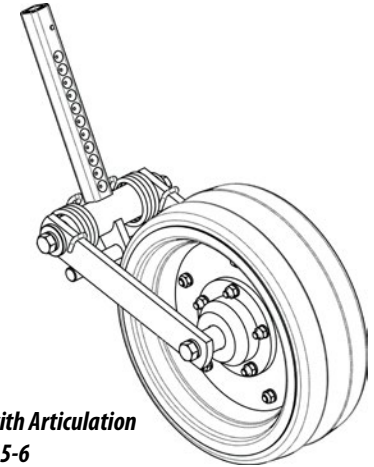

*Concave Compaction Wheel with Articulation*  
Code: 5498010055-6

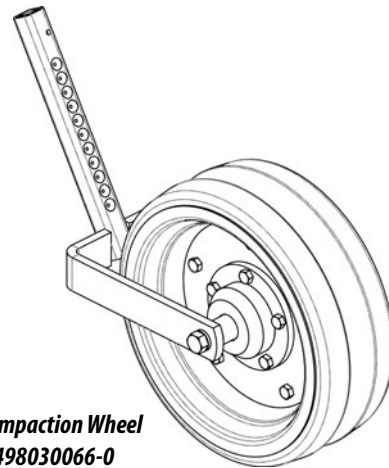

*Concave Compaction Wheel*  
Code: 5498030066-0

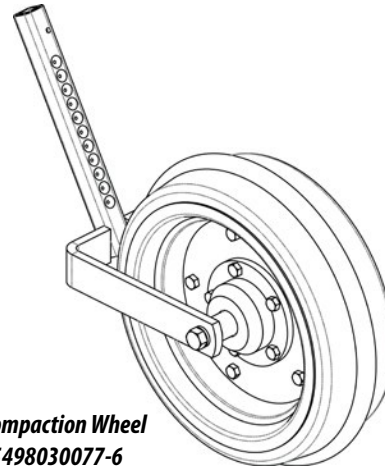

*Convex Compaction Wheel*  
Code: 5498030077-6

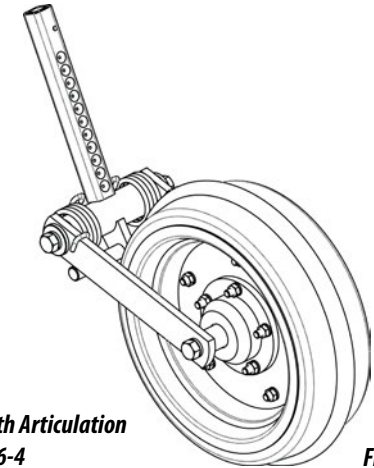

*Convex Compaction Wheel with Articulation*  
Code: 5498010056-4

Figures 26

## ASSEMBLAGE OF COMPACTION WHEELS (FIGURE 27) SAB / SHB 2000 / 2300 / 2600 / 3000

To assemble the compaction wheels on the lines of the SAB and SHB planter, proceed as follows:

- 1- Place the compaction wheel support (1) in the planting line (2), fixing with screws (3) lock nut (4) and lock (5).

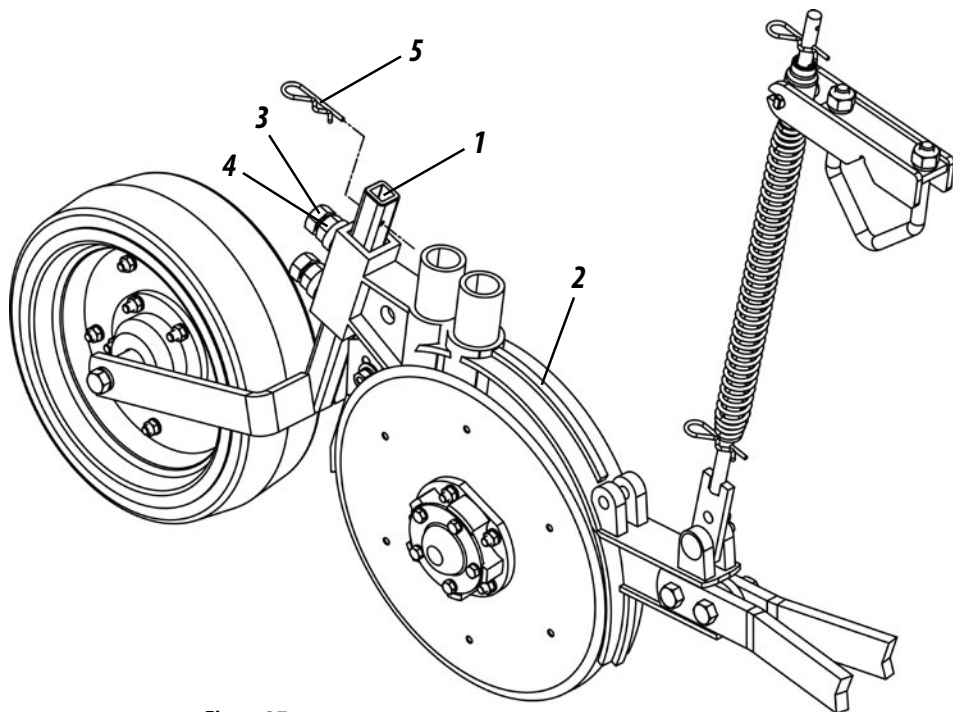

Figure 27

### IMPORTANT

Before starting the assembly of the compaction wheels in the planting lines, look for an ideal place to facilitate assembly.

### ATTENTION

When performing the assembly of the compaction wheel (1), do the same in the other planting lines.

## ADJUSTMENT OF THE WORKING DEPTH (FIGURE 28) SAB / SHB 2000 / 2300 / 2600 / 3000

The planting lines (1) can be individually adjusted to the working depth, if necessary. Proceed as follows:

- 1- Remove the lock (2), adjust the spring (3) through the holes of the rod (4), to give more or less working pressure in the planting line (1).

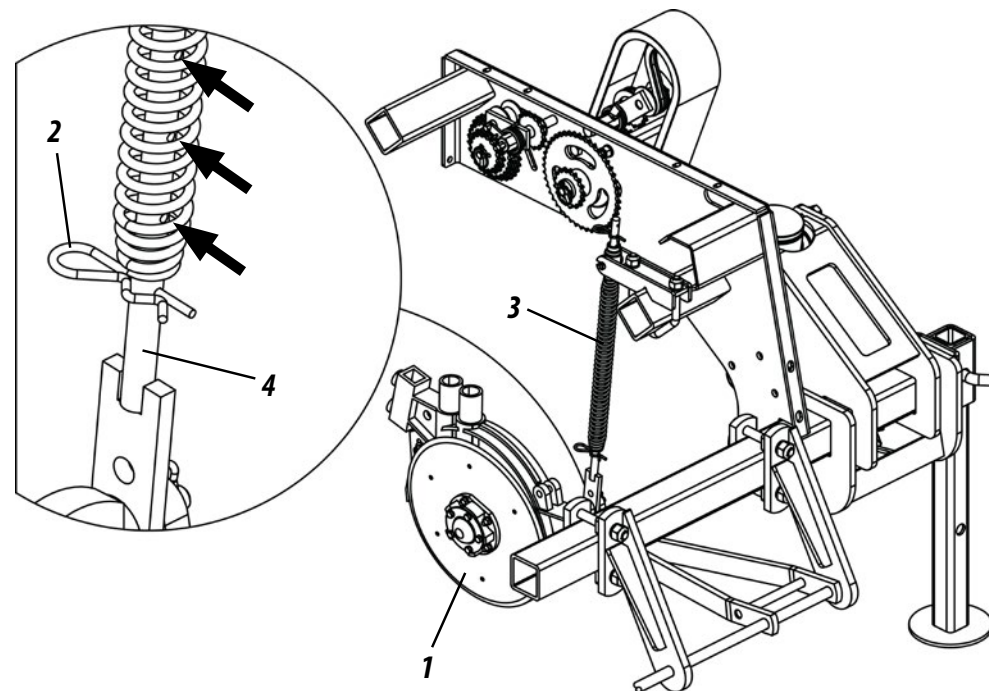

Figure 28

### IMPORTANT

During planting on lands with variations in soil moisture or others, check the working depth for each line.

### ATTENTION

Excess pressure in the spring can cause the planter to lift by the soil reaction to penetration.

## DEPTH LIMITING FRAME - OPTIONAL (FIGURES 29) SAB / SHB 2000 / 2300 / 2600 / 3000

The limiting frame (optional) has the objective of determining the depth position of seed and fertilizer. The limiting frame (optional) consists of the following components:

- 1 - Depth limiting frame
- 2 - Wiper support
- 3 - Frame wiper

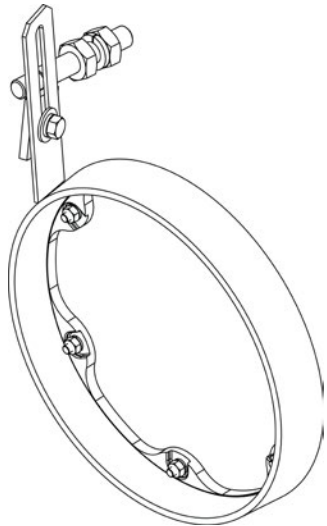

Left Depth Frame Cpl  
Code: 5288010046-7

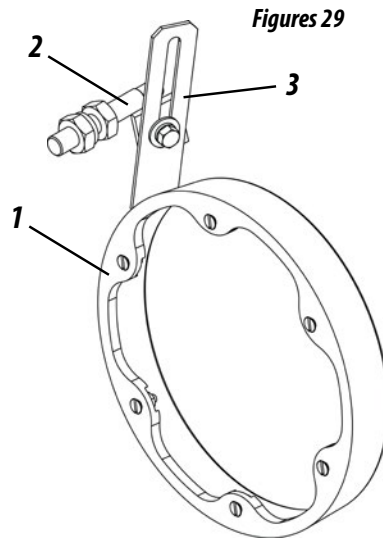

Right Depth Frame Cpl  
Code: 5288010047-5

Figures 29

- 1- Approach the limiting frame (1) to the double disc (2) and fix with screws (3), washers (4) and nuts (5).
- 2- Next, attach the wiper (6) in the wiper support (7) through the screw (8), pressure washer (9) and flat washer (10).
- 3- Finally, fix the wiper support (7) in the housing (8) through the nut and lock-nut (11) and pressure washer (12).

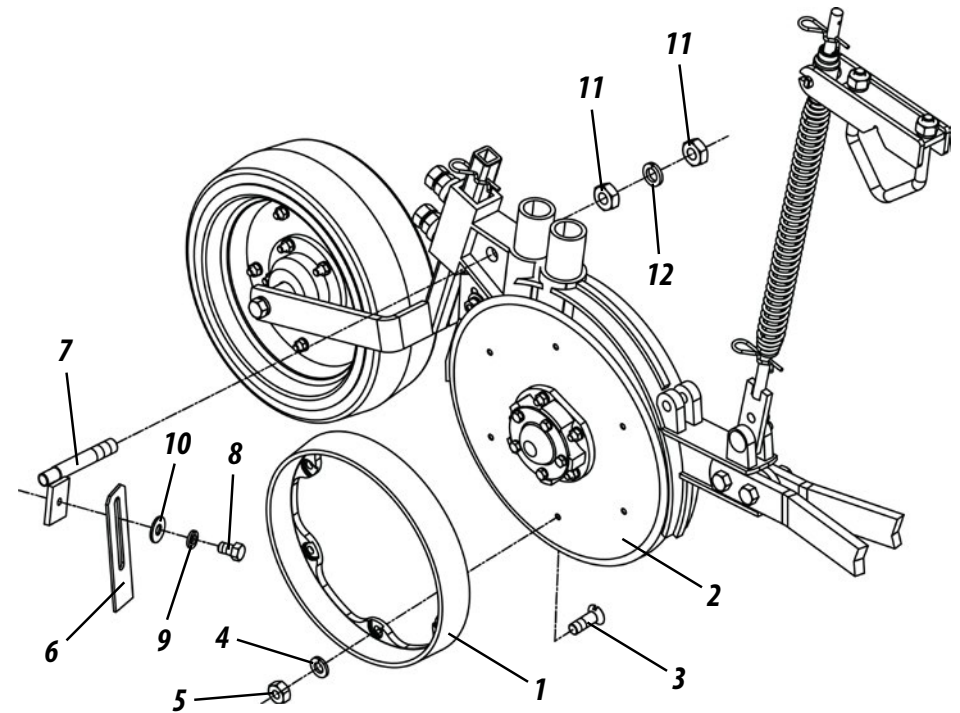

Figure 30

### ATTENTION

*In making the assembly of the limiting frame (1), do the same in the other planting lines.*

## ASSEMBLY OF THE DEPTH LIMITING FRAME - OPTIONAL (FIGURE 30) SAB / SHB 2000 / 2300 / 2600 / 3000

To assemble the limiting frame (1) in the planting line, do the following:

### IMPORTANT

*Before starting the assembly of the limiting frame (1) in the planting lines, look for an ideal place to facilitate assembly.*

### ATTENTION

*When performing the assembly of the limiting frame (1), do the same in the other planting lines.*

## ADJUSTMENT OF THE COMPACTION WHEEL (FIGURE 31) SAB / SHB 2000 / 2300 / 2600 / 3000

The compaction wheels (1) have the purpose of compressing the groove, causing the soil to be immediately placed on the seed, thus avoiding much compaction and facilitating plant germination. To make the adjustment of the compaction wheel, do the following:

- 1- Loosen the locknut (2) and screw (3), move the wheel to the desired position then retighten the locknut (2) and the screw (3).

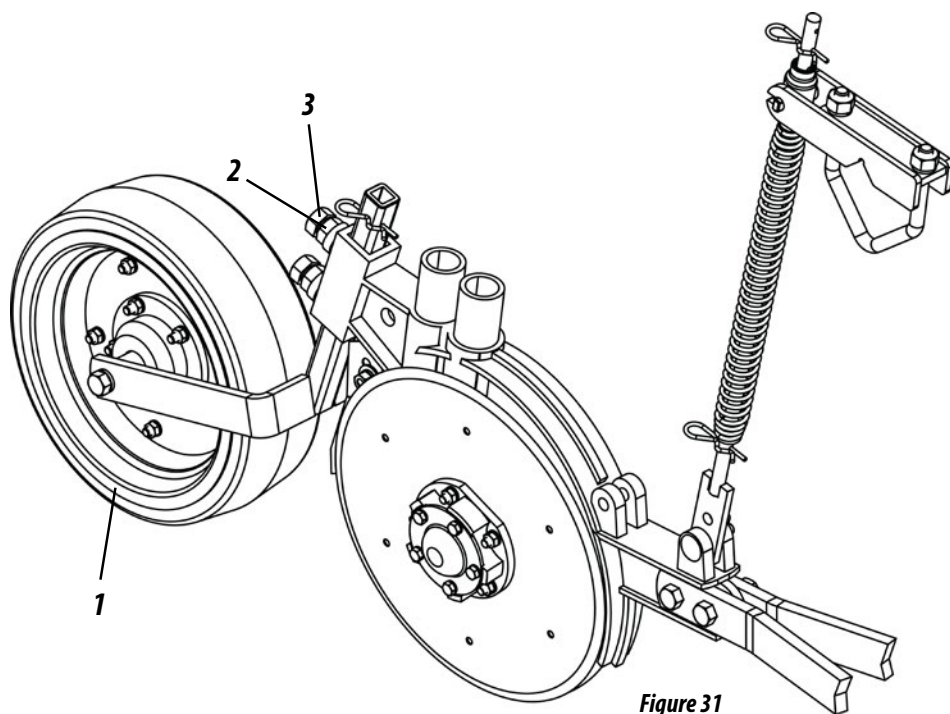

### **ATTENTION**

*When making adjustments in the compaction wheel, do the same on the other planting lines, consider the type of soil and seed and planting depth not to affect the plant emergence.*

## 12 - OPERATIONS

- 01 - After the first day of work with the planter, tighten all screws and nuts. Check the conditions of pins and locks.
- 02 - Always keep the tires with the same calibration of 70 lb / in<sup>2</sup>, to avoid wear and maintain planting uniformity.
- 03 - Observe lubrication intervals.
- 04 - When filling the seed and fertilizer tanks, check if there are no objects inside them, such as nuts, screws, etc.. Always use seed and fertilizer free of impurities.
- 05 - Always observe the functioning of mechanisms that distribute seeds and fertilizer and also the settings established at the beginning of planting.
- 06 - Keep the planter always leveled, the tractor drawbar must remain stable and working speed should remain constant.
- 07 - Always check depth of seed the fertilizer and the pressure of the compaction wheels.
- 08 - Check the position of the fertilizer in relation to seed in the soil.
- 09 - If case of doubts, do not operate or handle the planter, refer to the BALDAN After Sales.  
Phone: + 55 0800-152577 or E-mail: [export@baldan.com.br](mailto:export@baldan.com.br)

## 13 - MAINTENANCE

### CALIBRATION OF TIRES (FIGURES 32) SAB / SHB 2000 / 2300 / 2600 / 3000

- 1- Tires should always be properly calibrated to avoid premature wear due to excess or lack of pressure and ensuring accuracy in distribution.
- 2- Before calibrating the tires, check for the model used in SAB and SHB and check out the correct calibration below.

SAB - Tire 650 x 16 x 10 belts

SHB - Tire 5.60 x 15 x 10 belts

Figures 32

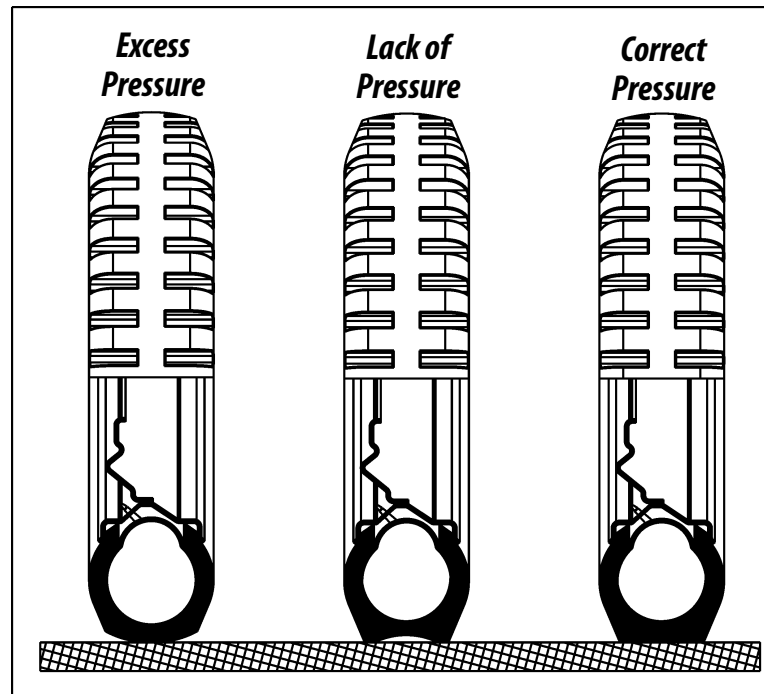
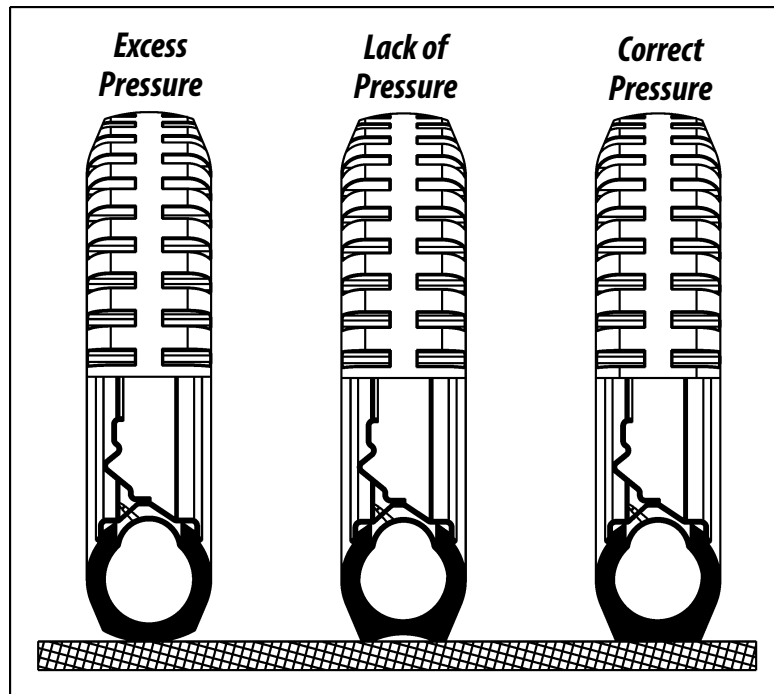

USE 70 LBS / POL<sup>2</sup>.

USE 44 LBS / POL<sup>2</sup>.

**ATTENTION**

When calibrating the tires of SAB and SHB, do not exceed the recommended calibration.

## LUBRICATION

### SAB / SHB 2000 / 2300 / 2600 / 3000

- 3- Lubrication is essential for good performance and durability of the planter moving parts, helping to reduce maintenance costs.
- 4- Before starting operation, lubricate all grease fittings carefully always observing lubrication intervals in the following pages. Make sure the lubricant is of good quality; avoid using products contaminated by water, dirt and other agents.

## TABLE OF GREASE AND EQUIVALENT (TABLE 07)

### SAB / SHB 2000 / 2300 / 2600 / 3000

Table 07

<b>MANUFACTURER</b>	<b>TYPE OF RECOMMENDED GREASE</b>
Petrobrás	Lubrax GMA 2
Atlantic	Litholine MP 2
Ipiranga	Super Graxa Ipiranga Ipírange Super Graxa 2 Ipiflex 2
Castrol	LM 2
Mobil	Mobilgrease MP 77
Texaco	Marfak 2 Agrotex 2
Shell	Retinax A Alvania EP 2
Esso	Multipurpose grease H
Bardahl	Maxlub APG 2 EP

 **IMPORTANT**

*If there are other lubricants and / or equivalent greases not listed in this table, refer to the manufacturer's technical manual.*

**LUBRICATE AT EVERY 10 HOURS OF WORK (FIGURES 33)  
SAB / SHB 2000 / 2300 / 2600 / 3000**

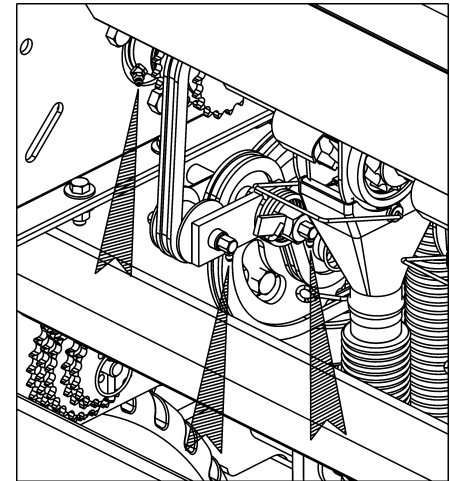
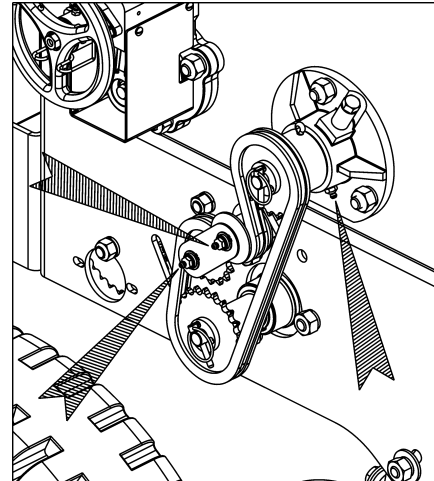
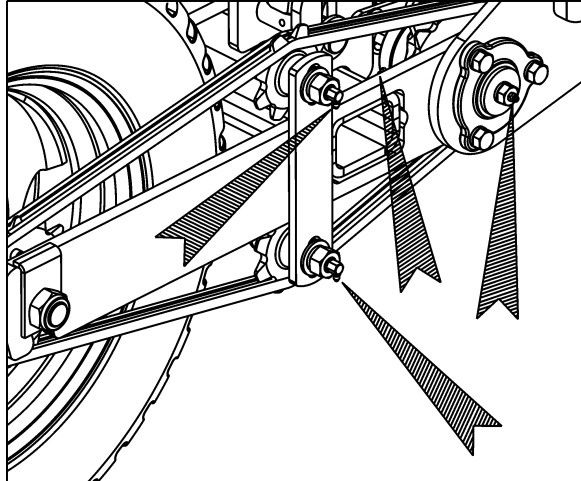
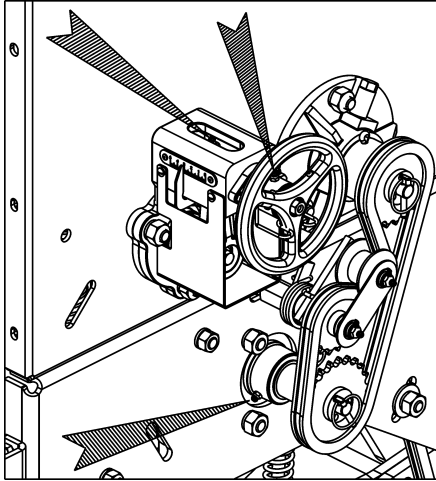

Figures 33

**LUBRICATE AT EVERY 30 HOURS OF WORK (FIGURES 34)  
SAB 2000 / 2300 / 2600 / 3000**

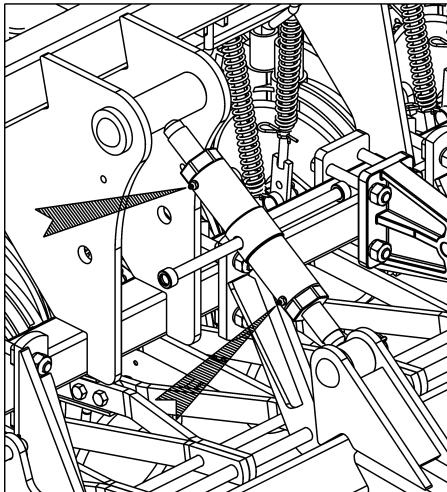

Figures 34

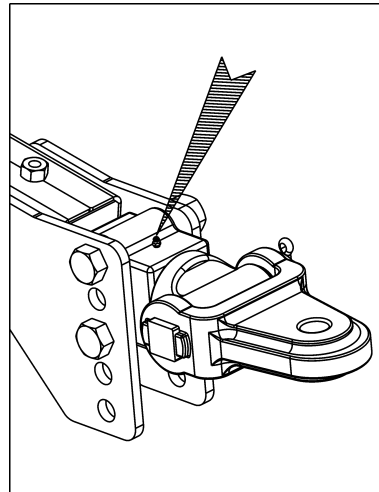

**LUBRICATE AT EVERY 60 HOURS OF WORK (FIGURE 35)  
SAB / SHB 2000 / 2300 / 2600 / 3000**

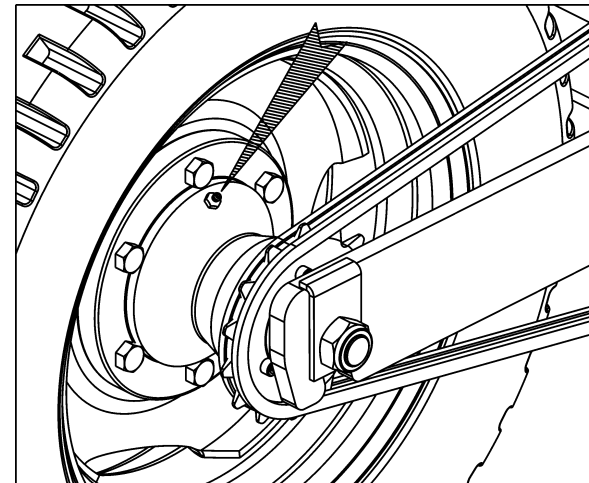

Figure 35

## LUBRICATE EVERY 200 HOURS OF WORK (FIGURE 36) SAB / SHB 2000 / 2300 / 2600 / 3000

Periodically lubricate hubs of double discs (1) approximately at every 200 hours and at the end of the harvest period. To do so, proceed as follows:

- 1- Remove the screws (2) and washers (3), remove the cap (4) and insert new grease. Replace the cap on the double disc and fix it with screws (2) and washers (3).

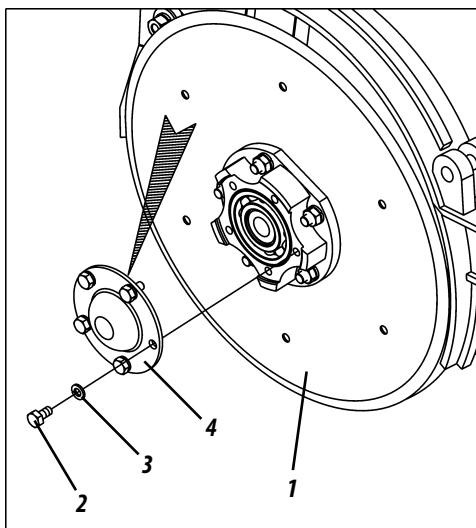
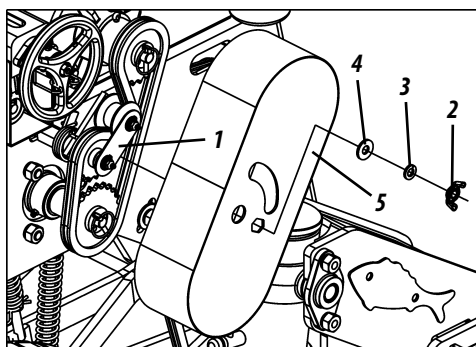

Figure 36

## TENSION OF THE CHAINS (FIGURES 37) SAB / SHB 2000 / 2300 / 2600 / 3000

The tensioner (1) is equipped with torsion spring to provide greater flexibility. To adjust the tension of the chains, do the following:

- 1- Loosen the wing nut (2), pressure washer (3), flat washer (4) and remove the protective cap (5).



Figures 37

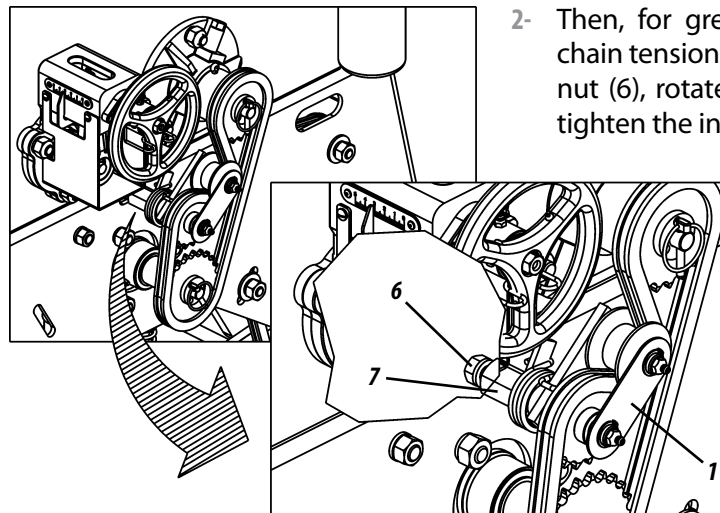

- 2- Then, for greater flexibility of the chain tensioner (1), loosen the inner nut (6), rotate the shaft (7) and re-tighten the inner nut (6).

Figures 37

- 3- Finally, fix the protection cap (5) through the flat washer (4), pressure washer (3) and wing nut (2).

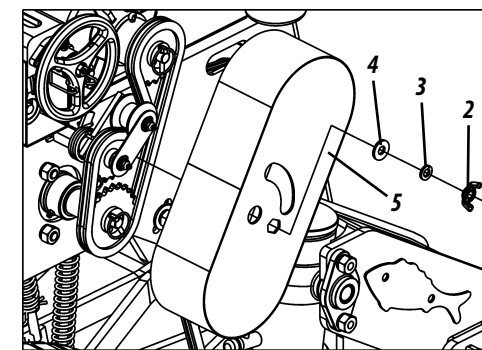

Figures 37



### ATTENTION

Never operate the SAB / SHB planters if the transmission protective caps (5) are not properly fixed.



### IMPORTANT

Check daily the tension of chains, the normal clearance should be  $\pm 1$  cm in the center thereof.

## OPERATIONAL MAINTENANCE SAB / SHB 2000 / 2300 / 2600 / 3000

<i>PROBLEMS</i>	<i>PROBABLE CAUSES</i>	<i>SOLUTIONS</i>
During planting, fertilizer leaks through the safety outputs.	Hoses are clogged or there are pieces of plastic in the spiral hoses that conduct the fertilizer.	Unclog the hoses or remove the upper channel that gives access to coil, rotate the shaft to the opposite side until the foreign body is removed.
Hub shaft of the fertilizer tank does not turn.	Spiral blocked with wet fertilizer or excess fertilizer in closed line.	Unclog the coils, check if there is loose gutter and if the fertilizer is coming in through their sides.
A planting line shows depth different from the other.	Different settings of pressure on the depth limiting wheels or in the line springs.	Adjust all depth wheels and the pressure of the line springs
Furrow opens too much during planting	Soil that sticks to the discs or excessive working speed.	Reduce the work speed.
Strange noise when operating or riding with the planter loaded.	Loose wheels or hub with clearance.	Retighten the nuts of the wheel. Adjust the bearings of the wheel hub.
The planter leaves the planting line, sometimes on one side, sometimes on the other.	Tractor drawbar loose.	Use the pin that came with the planter. Attach the tractor drawbar in the center hole.
Tractor lifts when machine lifts	Lack of weight on the front of the tractor	Put some weight on the front of the tractor
Machine goes aside during planting on slopes	Lower arms of tractor coupling are loose with side displacement	Fix the arms of tractor coupling in order to avoid side displacement
Hydraulic cylinders stop operating; planter lifts and does not come down and vice-versa	Different quick coupler; ball-type male and needle-type female or vice-versa	Replace the quick coupler, placing both of the same type.
Broken seeds	Too high planting speed.	Reduce the work speed. Reduce the work speed.
	Inadequate disc thickness.	Use adequate disc (thickness and diameter of the holes).
	Disc improperly assembled. The seed sieve is not suitable for the disc selected	Place the disc properly (see the phrase: THIS SIDE DOWN).
	Wet seed	Use dry seeds

## CARE

### SAB / SHB 2000 / 2300 / 2600 / 3000

- 1- Check the conditions of all nuts and screws before starting the use of the transshipment equipment.
- 2- The speed must be carefully controlled according to the terrain conditions.
- 3- The Baldan planters models SAB / SHB are used in various applications, requiring knowledge and attention during handling.
- 4- Only local conditions will determine the best mode of operation of planters.
- 5- When assembling or disassembling any part of the planter, use adequate methods and tools.
- 6- Check always parts that may show wear. If they need replacement, always ask for Baldan original parts.

## GENERAL CLEANING

### SAB / SHB 2000 / 2300 / 2600 / 3000

- 1- When storing the seeder, make a general clean and wash it. Make sure the paint did not wear off, if so, give an overall coat, pass protective oil and completely lubricate the planter.
- 2- Remove the transmission chains, and keep them immersed in oil until the next use.
- 3- Lubricate the machine completely. Check all moving parts, if they show signs of wear and clearances, make the necessary adjustment or replacement of parts, leaving the machine ready for the next use.
- 4- After all the maintenance procedures, store your planter in a covered and dry place, properly supported. Avoid the discs to be in direct contact with the ground.
- 5- We recommend washing the machine at the beginning of the new planting.



**ATTENTION**

*Do not use chemical cleaners to wash the planter; this may damage its painting.*

## 14 - IDENTIFICATION

### PRODUCT IDENTIFICATION (FIGURES 38) SAB / SHB 2000 / 2300 / 2600 / 3000

- 1- To view the parts catalog or request technical assistance from BALDAN, always indicate the model (1), serial number (2) and date of manufacture (3), which are on the identification label (4) of the planter.
- 2- **ALWAYS REQUIRE BALDAN ORIGINAL PARTS.**

Figures 38

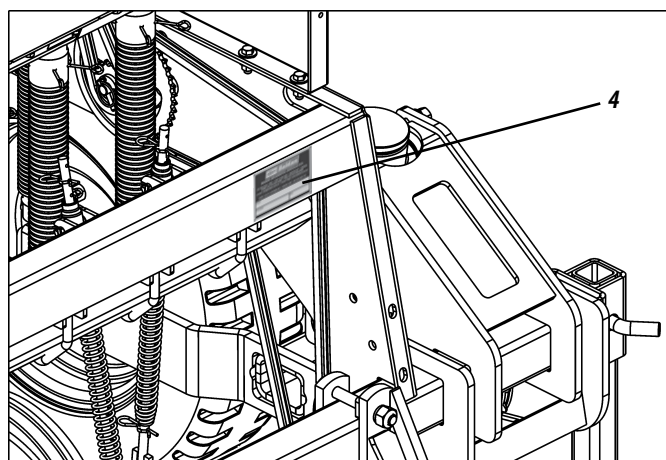

Make the identification of the data below to always have correct information about the life of your planter.

Owner's name: \_\_\_\_\_

Dealer: \_\_\_\_\_

Farm: \_\_\_\_\_

City: \_\_\_\_\_ State: \_\_\_\_\_

Warranty certificate Nr.: \_\_\_\_\_

Model: \_\_\_\_\_

Serial number: \_\_\_\_\_

Date of purchase: \_\_\_\_\_ Invoice Nr. \_\_\_\_\_

**CAUTION**

*The drawings in this instruction manual are of illustrative purposes only.*

**CONTACT**

*For questions, refer to the After Sales  
Phone: + 55 0800-152577  
E-mail: export@baldan.com.br*

**MARKETING**  
Edition of Catalogs and Manuals

Code: 60550105716  
CPT: SABSHB02517



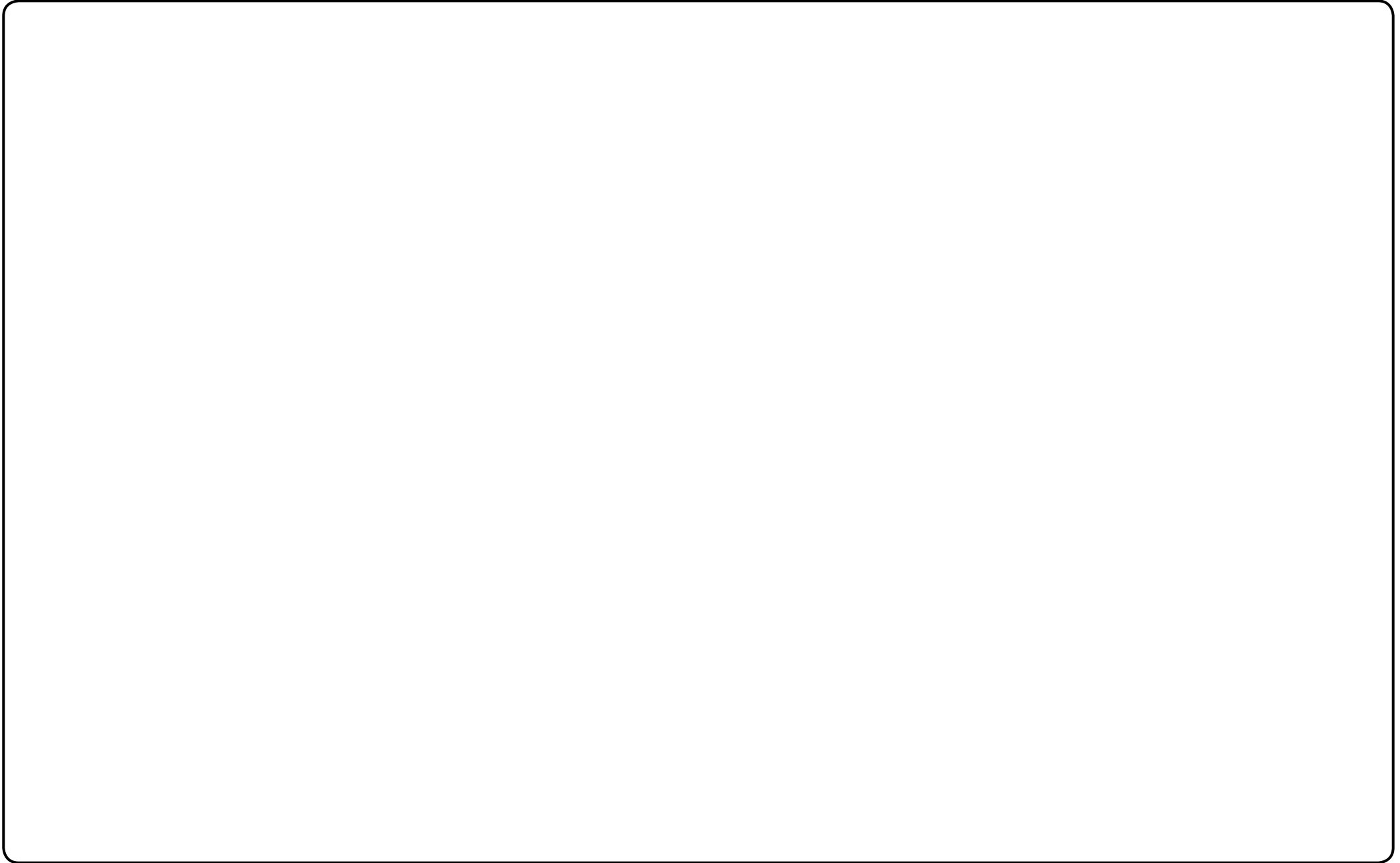



## **BALDAN IMPLEMENTOS AGRÍCOLAS S/A.**

Av. Baldan, 1500 | Nova Matão | CEP: 15993-000 | Matão-SP | Brasil

Phone: (0\*\*16) 3221-6500 | Fax: (0\*\*16) 3382-6500

Home Page: [www.baldan.com.br](http://www.baldan.com.br) | e-mail: [sac@baldan.com.br](mailto:sac@baldan.com.br)

Export: Phone: 55 16 3221-6500 | Fax: 55 16 3382-4212 | 3382-2480

e-mail: [export@baldan.com.br](mailto:export@baldan.com.br)

