

SLA *Speed Box Air* Séries 2500/3000



INSTRUCTION MANUAL



www.baldan.com.br



INTRODUCTION

We thank you for your preference and we congratulate you for the excellent choice you have just made, because you purchased a product manufactured by BALDAN IMPLEMENTOS AGRÍCOLAS S/A.

This manual will guide you through the procedures that are necessary from its acquisition to the operational procedures of use, safety and maintenance.

BALDAN ensures that it delivered this implement to the reseller, complete and in perfect condition.

The reseller is responsible for the custody and maintenance during the period in which it possesses it, and also for the assembly, retightening, lubrication and maintenance.

Upon technical delivery, the dealer should guide the user customer on maintenance, security, their obligation during possible technical assistance, the strict observance of the warranty and reading of the instruction manual. Any service warranty claims shall be made to the retailer where it was purchased from. We reiterate the need for careful reading of the guarantee certificate and the observance of all items in this manual, because doing so will increase the life of your implement.



TABLE OF CONTENTS

1 - Safety Standards	4 - 7
2 - Components:	
- Light Drag Seeder <i>SLA Speed Box Air</i> 3000	8
3 - Technical Specifications	9
4 - Assembly	10 - 12
5 - Coupling on the tractor	13
6 - Coupling on the cardan	14
7 - Adjustments and operations:	
- Spacing and position of the lines in the assembly	15
- New spacings	16 - 18
8 - Tailpiece:	
- System without tailpiece <i>SLA Speed Box Air</i> 2500	19
- System without tailpiece <i>SLA Speed Box Air</i> 3000	20
- System with tailpiece <i>SLA Speed Box Air</i> 3000	21
- Adjusting the line markers	22
9 - Adjustment for seeds:	
- Pneumatic seed distribution system (pneumatic dispenser)	23
- Distributors test	24
- Adjustments of seed limiters	25
- Viewing of seeds	26
- Vacuum regulation	27
10 - Adjustment for distribution of seeds:	
- Seed distribution table	28
- Fertilizer distribution system (metallic tank)	29 - 30
- Fertilizer distribution system (Polyethylene tank)	31
11 - Adjustment for distribution of fertiliser:	32
- Fertiliser distribution table	33
12 - Practical calculation for distribution of fertiliser and seeds	34 - 35
13 - Depth Adjustment	36
14 - Joint and wheel fastening system	37 - 39
- Operations	40
15 - Maintenance:	
- Tire pressure	40
- Centralised lubrication system	41
- Lubrication points	41
16 - Speed Box oil change	42 - 44
17 - Operational maintenance	44
18 - Cleaning:	
- Fertiliser System (Metallic tank)	45
- Fertiliser System (tank Polyethylene)	46
19 - Turbine:	
- Mechanical turbine drive belt	47
- Vacuum level in the perforated discs	48
- Seed System	49
20 - Optional equipment:	50
21 - Planting lines:	50 - 51
22 - Identification:	51
	52

01 - SAFETY STANDARDS



THIS SYMBOL INDICATES AN IMPORTANT SAFETY WARNING. WHENEVER YOU FIND IT IN THIS MANUAL, CAREFULLY READ THE MESSAGE THAT FOLLOWS AND BE AWARE OF THE POSSIBILITY OF PERSONAL INJURY.



ATTENTION

- Read the instruction manual carefully to become aware of the recommended safety practices.



ATTENTION

- Do not operate the tractor if the front is light.
- When there is a tendency to lift, add weights at the front or on the front wheels



ATTENTION

- Only begin operating the harvester when properly accommodated and when wearing the seat belt fastened.



ATTENTION

- There are risks of serious injury by overturning when working on slopes.
- Do not use excessive speed.

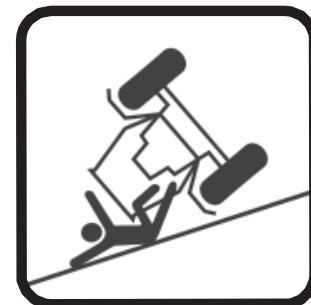

**ATTENTION**

- The hydraulic oil is pressurised and can cause serious injury if leaks occur.
- Periodically check the state of conservation of hoses. If there are signs of leakage, replace immediately.
- Before connecting or disconnecting the hydraulic hoses relieve system pressure, triggering this with the tractor switched off.

**ATTENTION**

- Do not operate the seeder if the protections of the transmissions are not properly secured.
- Only remove the protections to carry out exchanging of gears, replace them immediately.
- Do not make adjustments with the machine in motion.

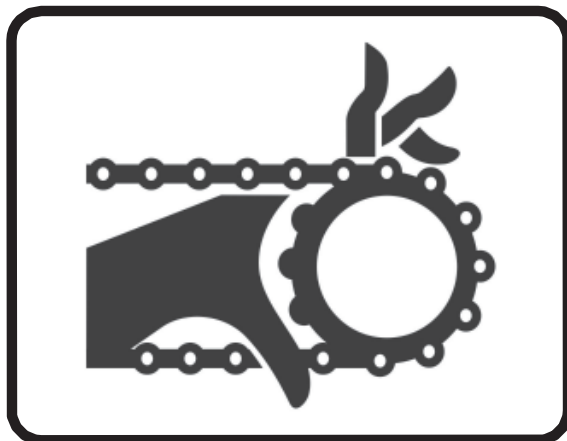
**ATTENTION**

- When operating the seeder do not allow that people be on the machine.
- Do not stay on the seeder in motion.





ATTENTION

- Keep yourself away from the moving elements of the machine (Discs), as they are sharp and can cause accidents.
- In doing any service to the discs use safety gloves on your hands.



ATTENTION

- Before any maintenance on your equipment, make sure it is properly stationary. Avoid getting run over.

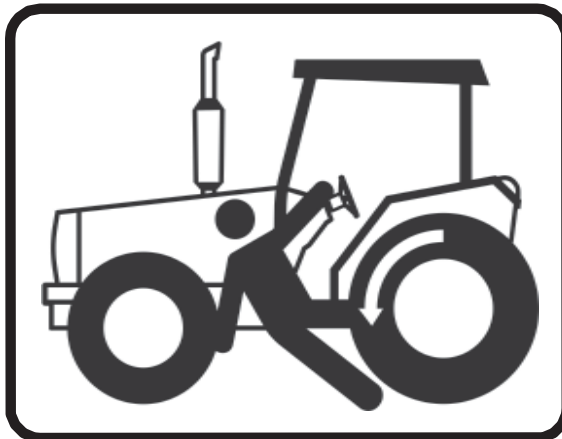

ATTENTION

- Avoid accidents caused by the intermittent action of the line markers.
- When activating the seeder make sure there is nobody under the line markers or in their working area.





ATTENTION

- Check the oil level.
Change the oil from the speed box after the first 30 hours, and after that, every 1500 hours when using mineral oil ISO BV 150 at 40°C (amount of oil used is 1.8 litres).
- Use only an original factory fuse because only it has controlled hardness.

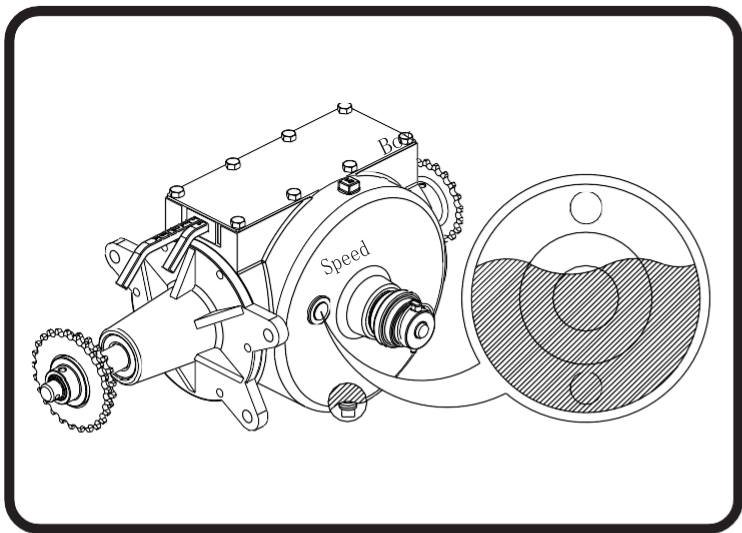

ATTENTION

The turbine can expel toxic waste products used in seed treatment.

- Do not be exposed to the air which leaves the turbine when it is in operation.

Read the label of the product used for the treatment of seeds.

- During handling, application and planting use personal protective equipment (PPE).
- Wash your hands after handling the products.
- Treated seeds should not be exposed to persons outside the service, domestic animals, birds nor come into contact with human or animal consumption products.
- In case of poisoning by inhalation or aspiration, keep the person in a place with fresh air and seek medical attention immediately, taking the label or packaging of the chemical.

















POISONING SYMPTOMS: Weakness, headache, chest tightness, blurred vision, non-reactive pupils, abundant salivation, sweating, nausea, vomiting and abdominal cramps.



ALCOHOLIC DRINKS OR SOME TYPES OF MEDICATION CAN GENERATE LOSS OF REFLECTIONS AND CHANGE THE PHYSICAL CONDITIONS OF THE OPERATOR. SO DO NOT OPERATE THIS EQUIPMENT UNDER THE USE OF SUCH SUBSTANCES.

WARNING: The mishandling of this equipment can result in serious or fatal accidents. Before putting the equipment into operation, please read the instructions in this manual. Make sure that the person responsible for the operation is instructed on the proper and safe handling and if they have read and understood the instruction manual for this product.



- 1 -  When operating the equipment, do not allow people to stay very close to it or on it.
- 2 -  When making any assembly and dismantling service on the discs wear gloves on your hands.
- 3 -  Before you connect or disconnect the hydraulic hoses, relieve the system pressure by triggering the command with the tractor off.
- 4 -  Periodically check the condition of hoses. If there is oil leaking evidence replace the hose immediately because the oil works under high pressure and can cause serious injury.
- 5 -  Do not wear loose clothing as it can curl up on the equipment.
- 6 -  When running the tractor engine, remain properly seated in the operator's seat and be sure to have complete knowledge of the proper and safe handling of both the tractor and the implement. Always place the gearshift lever in neutral, turn off the power supply command and place the hydraulic controls in neutral.
- 7 -  Do not run the engine indoors without adequate ventilation, as the exhaust gases are harmful to health.
- 8 -  When maneuvering the tractor to couple the implement, make sure that you have the necessary space and that there are no people very close, always make maneuvers in low gear and be prepared to brake in an emergency.
- 9 -  Do not make adjustments with the implement in operation.
- 10 -  When working on sloping terrains, proceed with caution when trying to maintain the necessary stability. In the case of an imbalance start, reduce the throttle, turn the tractor wheels towards the downslope of the terrain.
- 11 -  Always drive the tractor at speeds compatible with safety, especially when working in rough terrain or slopes, always keep the tractor engaged.
- 12 -  When driving the tractor on roads, keep the brake pedals connected and use safety signs.
- 13 -  Do not operate the tractor if the front is light. If there is a tendency to lift, add weights at the front or on the front wheels.
- 14 -  When leaving the tractor put the gear lever in neutral and apply the parking brake.

LIGHT DRAG SEEDER SLA Speed Box Air 2500 /3000

02 - COMPONENTS

- 01 Fertilizer tank
- 02 Seed tank
- 03 Complete line marker
- 04 Platform railing
- 05 Complete line
- 06 Seeds double-disc
- 07 Stairs
- 08 Cutting disc
- 09 Support bracket
- 10 Coupling pin
- 11 Full coupling header
- 12 Agricultural cardan
- 13 Hydraulic hoses
- 14 Hydraulic cylinder line marker
- 15 Speed Box
- 16 Assembly
- 17 Mechanical turbine
- 18 Air duct
- 19 Protective Case
- 20 Rear platform
- 21 Seeds double-disc

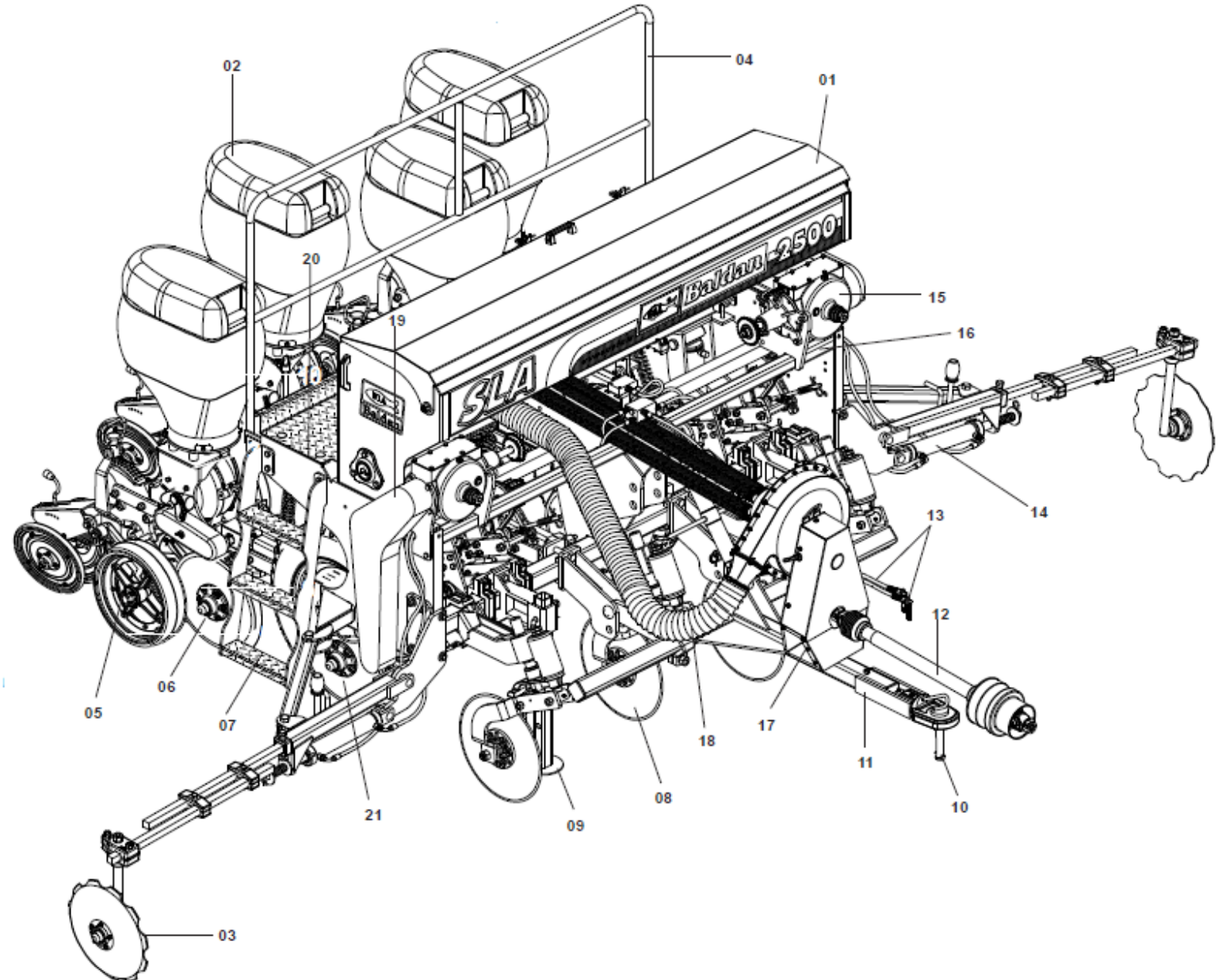

03 - TECHNICAL SPECIFICATIONS

Model	Number of Lines	Power of the tractor HP	Weight Approx. (Kg)	Yield Medium (Ha / Day)	Width Useful (mm)	Width Total (mm)	Height Total (mm)	Fertiliser tank capacity (LT)		Tank capacity of seeds per line (LT)	Wheel set	Number of Wheels
								Metallic	Plastic			
								SLA Air 2500	5			
Model	Number of Lines	Power of the tractor (Hp)	Weight Approx. (Kg)	Yield Medium (Ha / Day)	Width Useful (mm)	Width Total (mm)	Height Total (mm)	Fertiliser tank capacity (LT)		Tank capacity of seeds per line (LT)	Wheel set	Number of Wheels
SLA Air 3000	7	60 - 80	2650	11	2770	3500	1900	570 L	615 L	45	Agricultural 650 x 16 x 10L	02

TABLE 01.

* Working width and spacing, see Table 02 on page 15

- Minimum line Spacing 415 mm
- Minimum spacing between lines in the wheel set 450 mm
- Working depth 0 to 120 mm
- Total length. 4000 mm

BALDAN reserves the right to change the specifications of this product without notice. The technical specifications are approximate and informed in normal working conditions.

04 - COUPLING HEADER

ASSEMBLY

- 1 - The seeder leaves the factory semi-assembled, lacking only the mounting of some components, to be mounted as indicated below:
- 2 - Place the header (1) in the working position by removing the lock (2) and the pin (3) that were placed for transport. **(FIGURE 02)**
- 3 - Place the regulator (4) on the header by fixing it with the pin (5) and lock (6) and the pin (7) and lock (8) on the assembly support. **(FIGURE 03)**

FIGURE 02

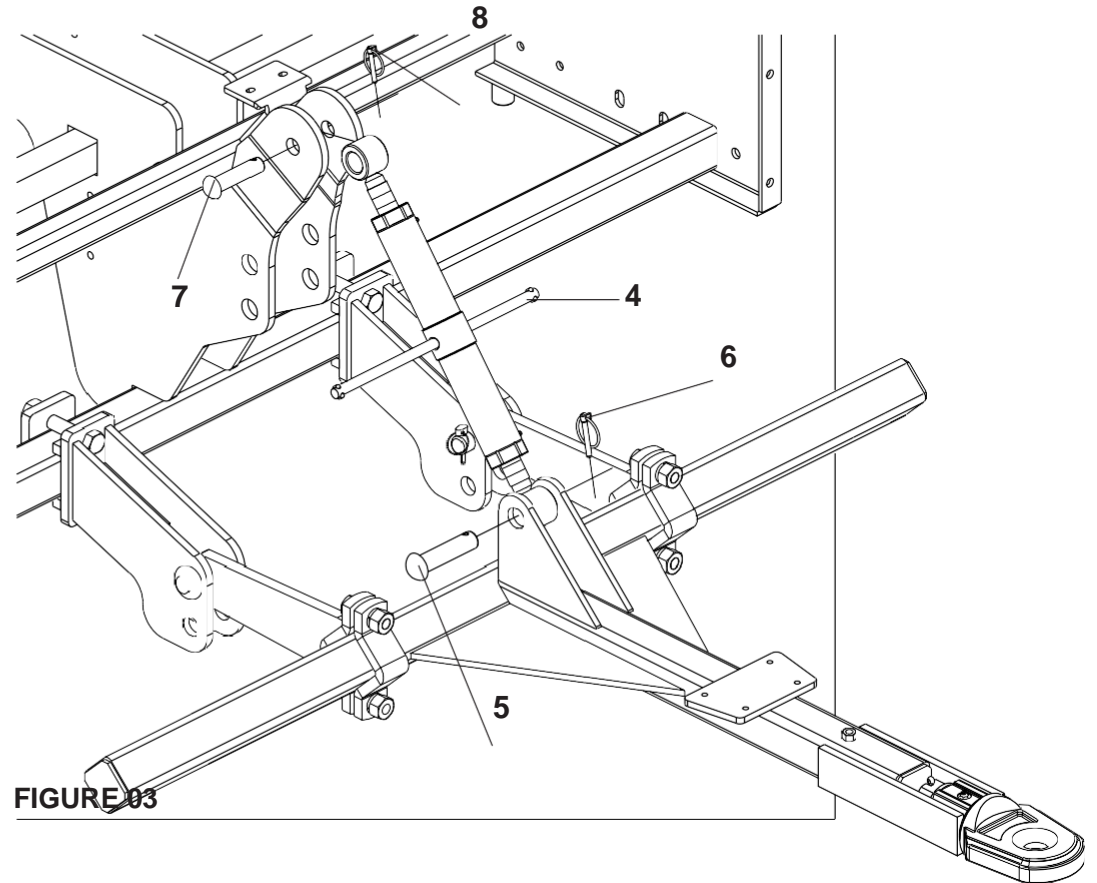
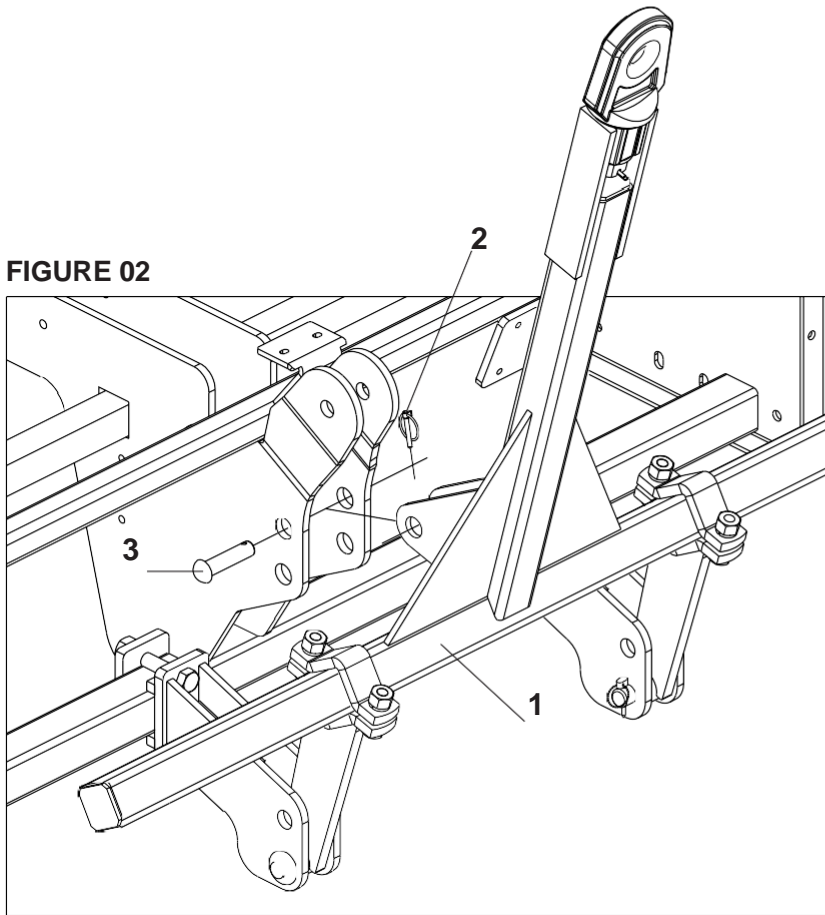

FIGURE 03

ASSEMBLY OF TURBINE TO THE HEADER (FIGURE 04).

- 4 - Attach the turbine (1) to the assembled header (2) using the screws (3), washers and nuts (4).

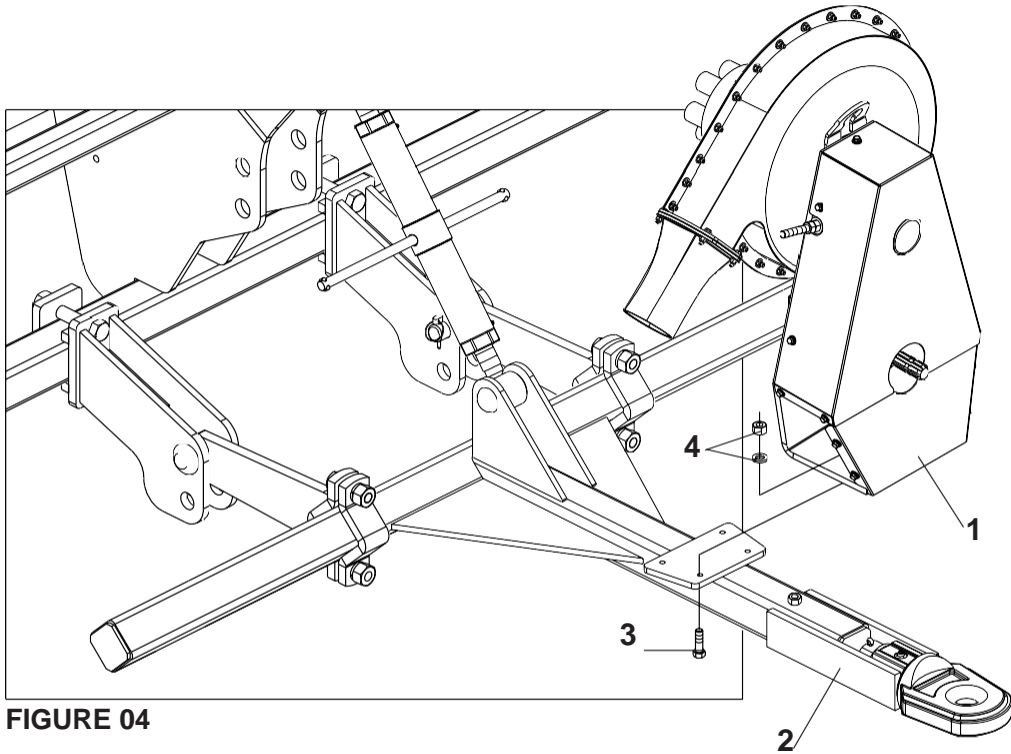

FIGURE 04

TURBINE ASSEMBLY (FIGURE 05).

- 5 - Insert the primary air ducts (6) at the rear entrance of the turbine (7). Fixing it with the clamp (8).
- 6 - Insert the secondary air duct (9) in the side air outlet (10), fixing it with the clamp (11).
- 7 - Pass the hydraulic hoses (12) through the inside of the support welded on the side of the turbine.
- 8 - Couple the cardan (13) in the slotted shaft (14) of the turbine pulley and lock with the safety lock (15) of the cardan itself.

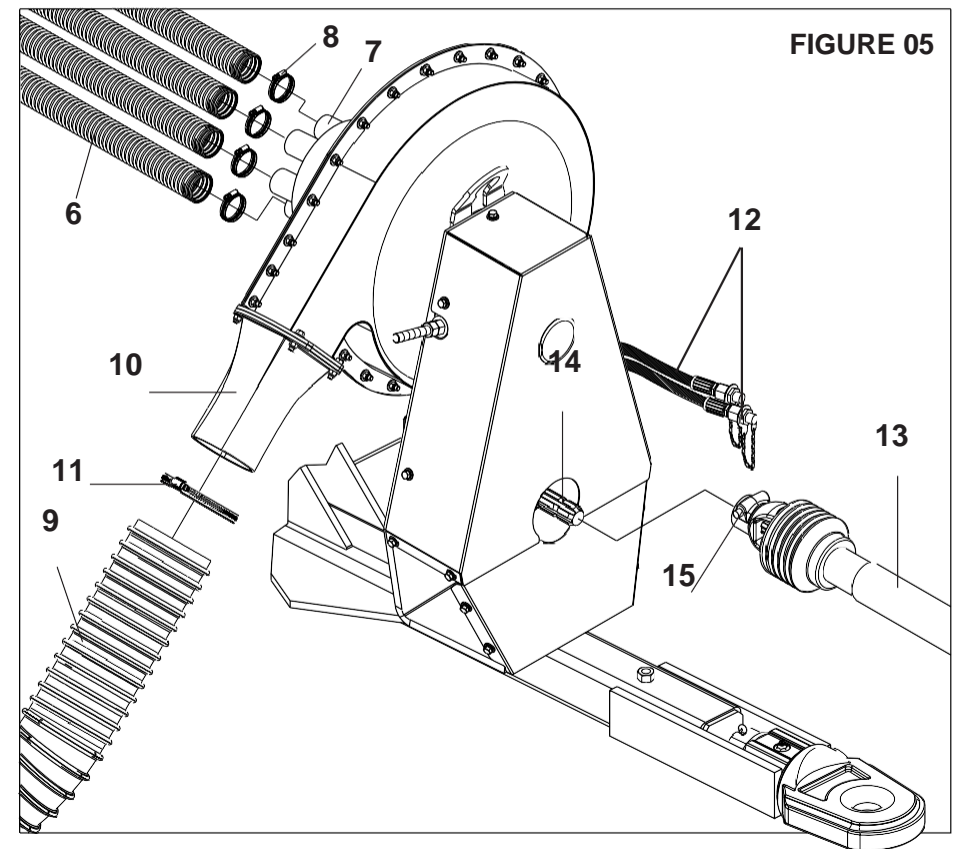

FIGURE 05



IMPORTANT

Always keep the secondary duct (9) facing the rear output of the seeder, since the turbine can expel toxic waste used in seed treatment.

ASSEMBLY OF COMPACTOR WHEELS (FIGURE 06)

1 - Attach the wheel support (1) the wheel cart (2), fixing it with the bushings (3), washer (4) and screw (5). Place the lever (6) fully forward (**position "A"**) and engage the spring (7) on the support of wheel (1).

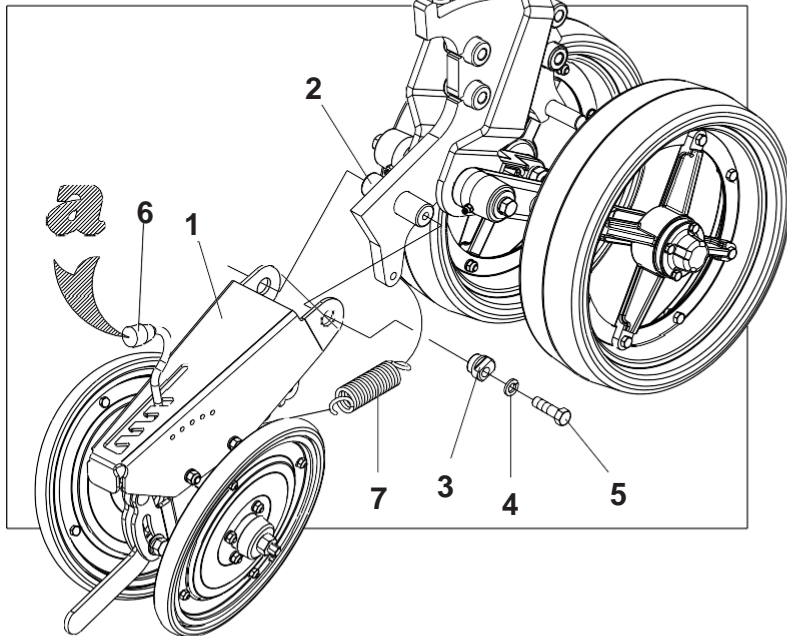

ASSEMBLY OF THE CART OF THE COMPACTOR AND DEPTH WHEEL (FIGURE 07)

2 - Insert the full cart of the wheel (1) between the planting line plates (2), fixing them with the screws (3), washers and nuts (4).

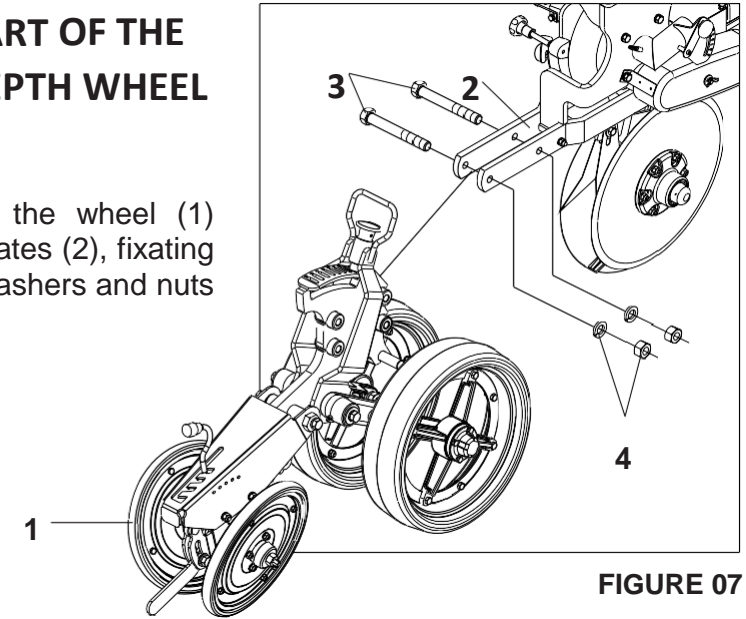

FIGURE 07

LINE MARKER ASSEMBLY (FIGURE 08)

3 - Insert the square bar of the marker (1) in the support (2), fixing it with the screws (3).

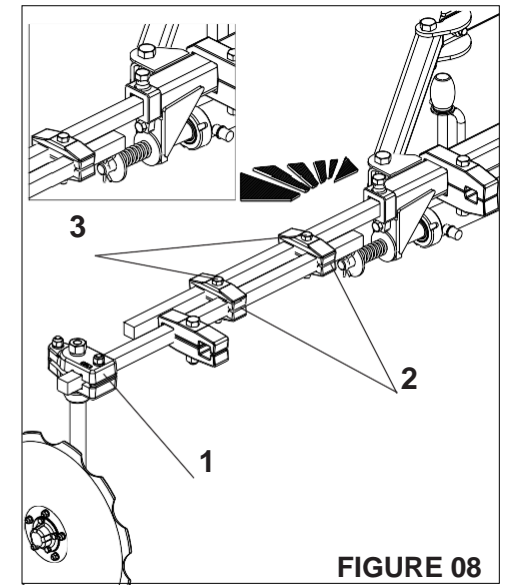

FIGURE 08



IMPORTANT

Once assembled, carry out a general review of the seeder make sure there are no objects (nuts, bolts or others) inside the tanks. Retighten all nuts and bolts, check all pins, cotter pins and locks, check all the hoses.

05 - COUPLING TO THE TRACTOR

1 - Level the header of the seeder in relation to the coupling of the tractor through the regulator (1).

2 - Proceed to couple the seeder to the tractor via pin of coupling (2) place the lock (3). **(FIGURE 09)**

3 -  When engaging the seeder find a safe and easily accessible place, always use a low gear with low acceleration.

4 - Attach the hoses (4) to the quick coupling of the tractor.

5 -  Before connecting or disconnecting the hydraulic hoses, stop the engine and relieve the pressure from the hydraulic system by fully activating the control levers. Make sure that when relieving the system pressure, no one is near the machine's movement area.

SEEDER TRANSPORTATION

6 - Lower the support bracket (1). **(FIGURE 10)**

7 - With the seeder lowered, make sure it is levelled in relation to the tractor, otherwise level it with the header regulator (1). **(FIGURE 09)**

8 - Raise the lines through the activation of the full travel of the hydraulic cylinder. Place the lock (2) on the cylinder rod. **(FIGURE 11)**

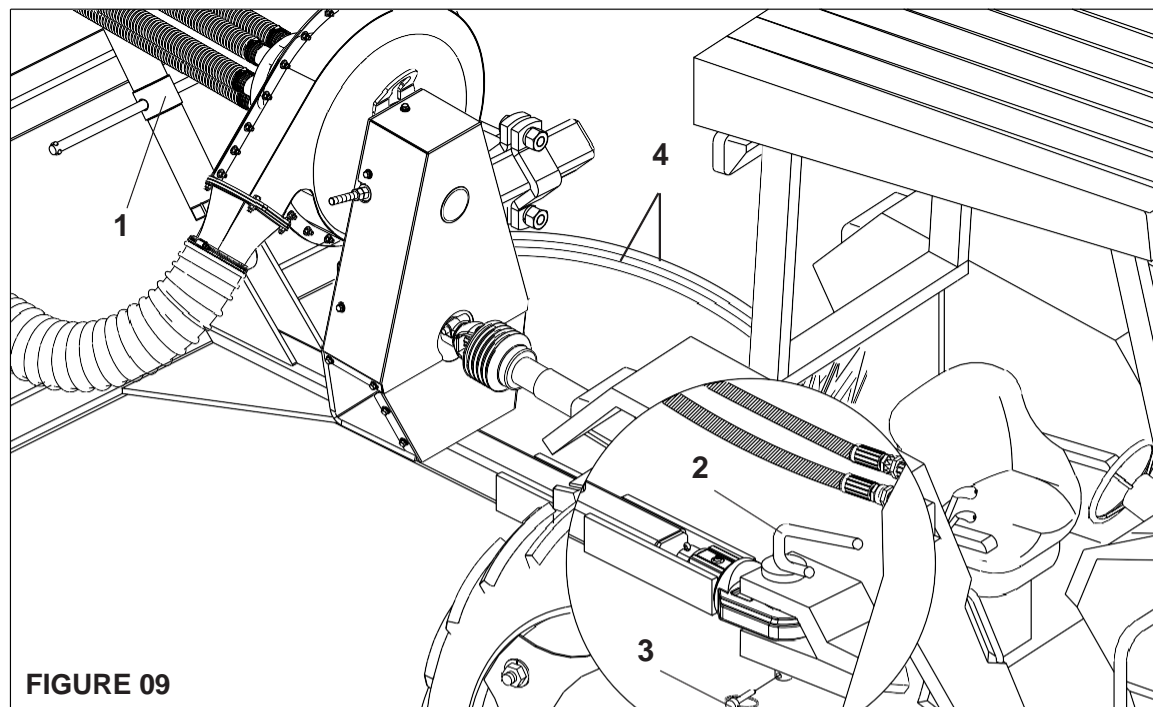

FIGURE 09



IMPORTANT

Do not carry the seeder when loaded, it may damage the equipment. We recommend filling it only in the workplace. If the seeder is to remain in the field for any reason, we recommend covering it with tarpaulin to prevent moisture.

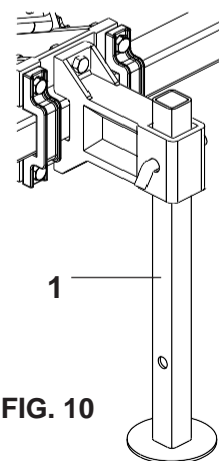

FIG. 10

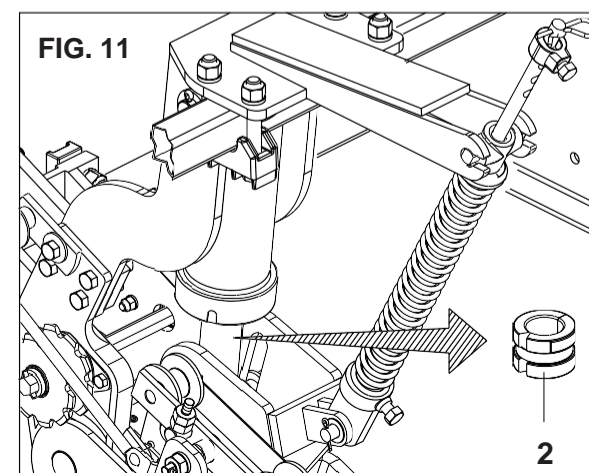
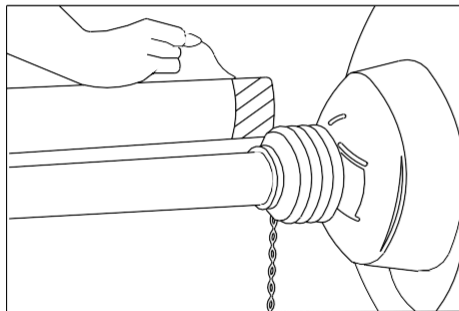

FIG. 11

06 - COUPLING OF THE CARDAN - TYRE SYSTEM W / MECHANICAL TURBINE (FIGURES 12).

01 Before coupling the cardan, check its length in relation to the tractor model that will pull the seeder. If necessary, proceed by cutting the cardan as follows:

FIGURES 12



Fasten the halves of the cardan shaft close to each other in the working position and make the marking of the part to be cut.

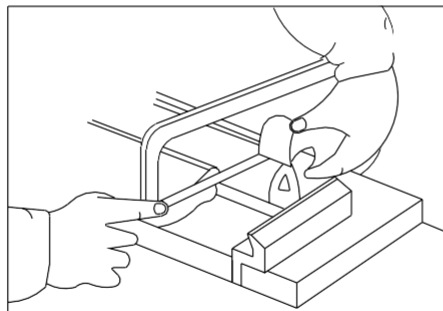

Shorten the inner and outer protective tubes of the cardan proportionally.

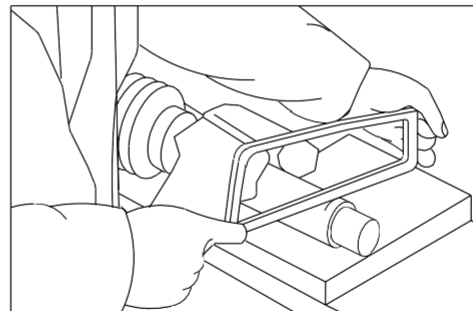

Cut the inner and outer bars of the cardan at the same length as the protective tubes. **NOTE:** Leave a smaller gap of ± 5 cm.

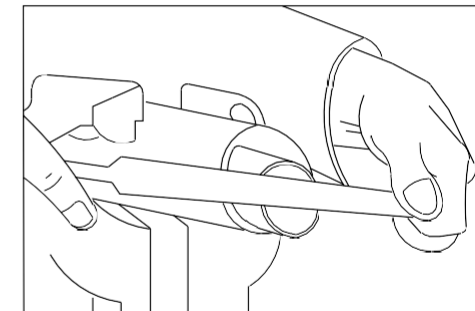

Remove all burrs and tips. Clean and grease the sliders of the cardan.

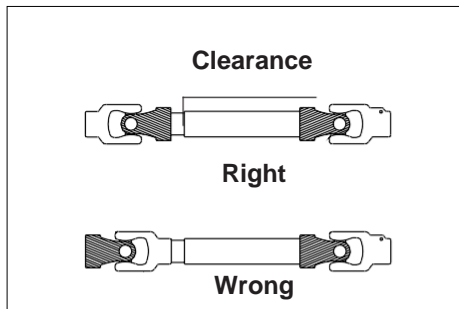

During assembly, note that the internal and external terminals are always aligned in the same plane. Also check the slack in the telescopic shaft, which must be at least 5 cm.

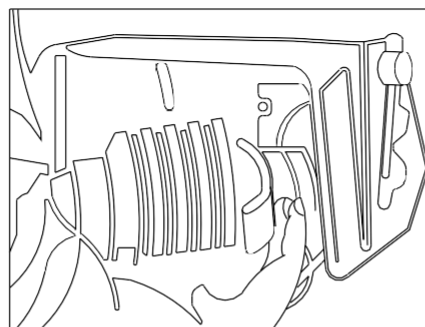

Attach the flange on the shaft of the **TDP** of the Tractor, noting that the coupling will only be complete when the latch jumps.

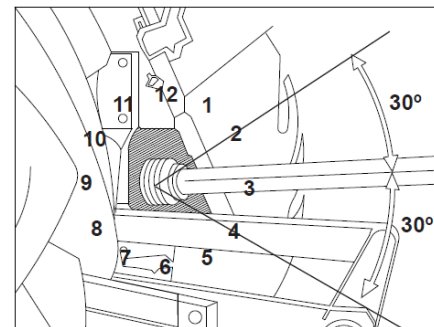

! When coupling the cardan to the **TDP**, the tractor must be with the engine off and the parking brake applied.

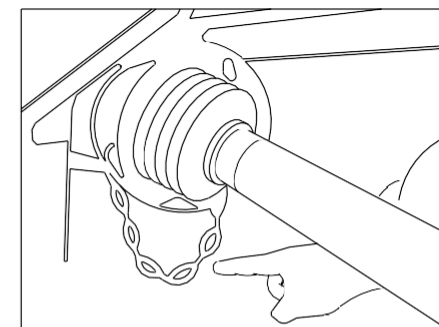

Do not engage the chains of the cardan when stretched. Keep a gap in the installation and consider the angular movements.

IMPORTANT

In excessively tight manoeuvres, disconnect the cardan.

07 - ADJUSTMENTS AND OPERATIONS

LINE SPACING

- 1 - The seeders are provided with spacing according to the number of lines requested, new spacings may be provided according to the desired type of crop.
- 2 - Spacings table.

SPACINGS TABLE:

TABLE 02

Model	No. of lines	Maximum spacing [mm]	Working width [mm]
SLA Air 2500	5	415, 450	2075, 2250
	4	500, 550, 600	2000, 2200, 2400
	3	650, 700, 750, 800, 850, 900	1950, 2100, 2250, 2400, 2550, 2700
Model	No. of lines	Maximum spacing [mm]	Working width [mm]
SLA Air 3000	7	415, 450	2905, 3150
	6	500, 550	3000, 3300
	5	550, 600, 650	2750, 3000, 3250
	4	700, 750, 800, 850, 900	2800, 3000, 3200, 3400, 3600



IMPORTANT

The minimum spacing between the wheel set lines is 450mm.

POSITION OF THE LINES IN THE ASSEMBLY (FIGURES 13)

- 3 - Check on the assembly where the planting lines will be fixed. For an odd number of lines, attach a line in the centre of the assembly, following this for the others, according to the desired spacing.

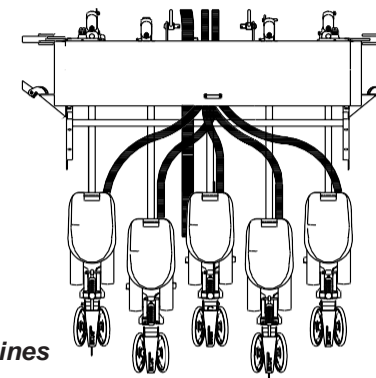

Odd lines

FIGURES 13

- 4 - For the even number of lines, mark the centre of the assembly, divide one spacing and mark 1/2 (half) of a spacing to the left and 1/2 (half) to the right. Attach there the first two lines and based on them set the others in the desired spacing.

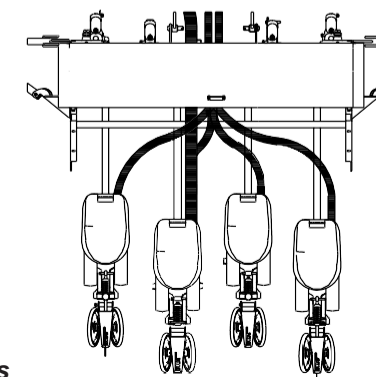

Even lines

FIGURES 13

NEW SPACINGS

1 - To make new spacings between lines, raise the seeder by activating the piston. Place the rear support bracket (1) lower the support bracket (2) with the locking pin (3). **FIGURES 14**

2 - Operate the hydraulic cylinder again so that the planting lines are suspended.

3 - When making new spacings, if necessary, remove some lines to increase spacing, proceed as follows:

FIGURE 15

- Remove the locks (4) from the end of the shaft, loosen the screws (5) securing the transmission gear (6), loosen the screws (7) releasing the locks (8), then remove the hex shaft (9).

- Check the lines to be removed or displaced. Release the nuts of the springs support (10), remove the coupling clamps (11) of the lines and also the spacer bars (12) through the screw with bushing, washer and nut (13);

- Finally, remove the complete planting lines by pulling them back;

- Replace the shaft (9) and the locks (4). Align the gear (6) and retighten the screws (5);

- Slide the rows to the determined spacing. Retighten the nuts of the clamps (11);

- Reposition the locks (8) on the sides and retighten the screws (7);

- Replace the spacer bars (12), making sure the spacing is the same as the spring rod.

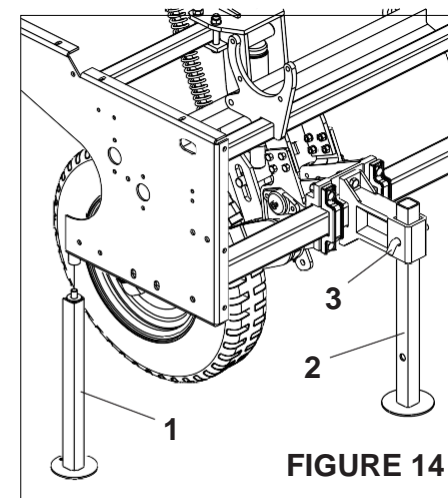

FIGURE 14

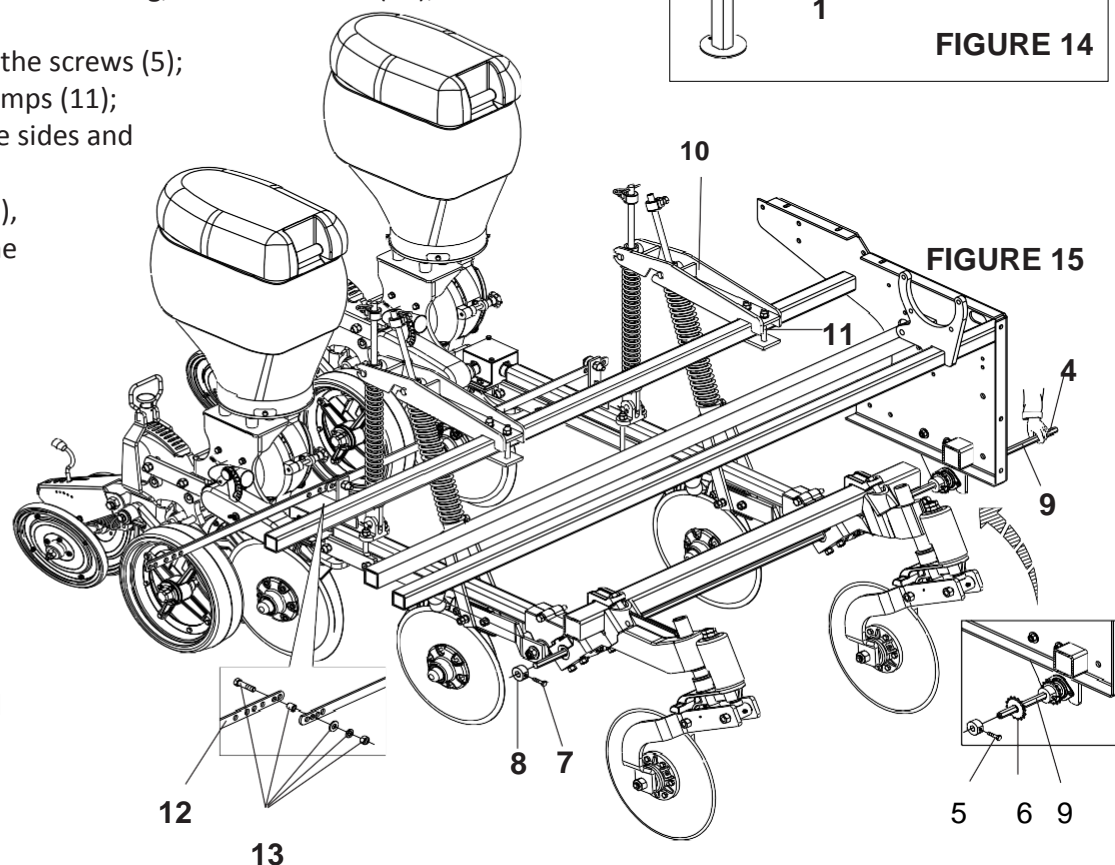
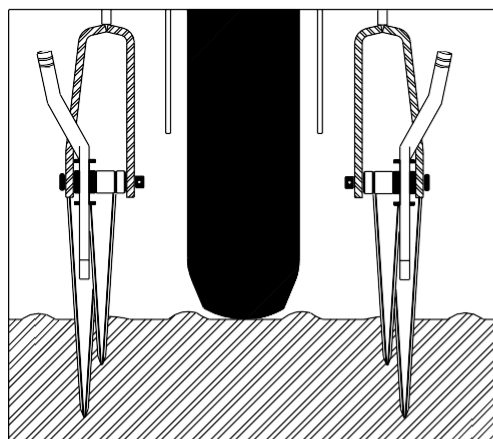

FIGURE 15



IMPORTANT

When repositioning the lines, observe their assembly on the sides of the tires, putting the left line on the right side thereof, as detailed below.

POSITION OF THE WHEEL (FIGURE 16)

- 1 - To change the wheel position, loosen the nuts (1), of the lock support and of the wheel clamps.
- 2 - Loosen the ratchet through the screw (2), releasing the whole set to move it.
- 3 - Slide the wheel sets and ratchet to the desired position, retighten the nuts (1) and lock the ratchet with screw (2).
- 4 - Note the alignment of the wheel gears and ratchet with the transmission chain (3).

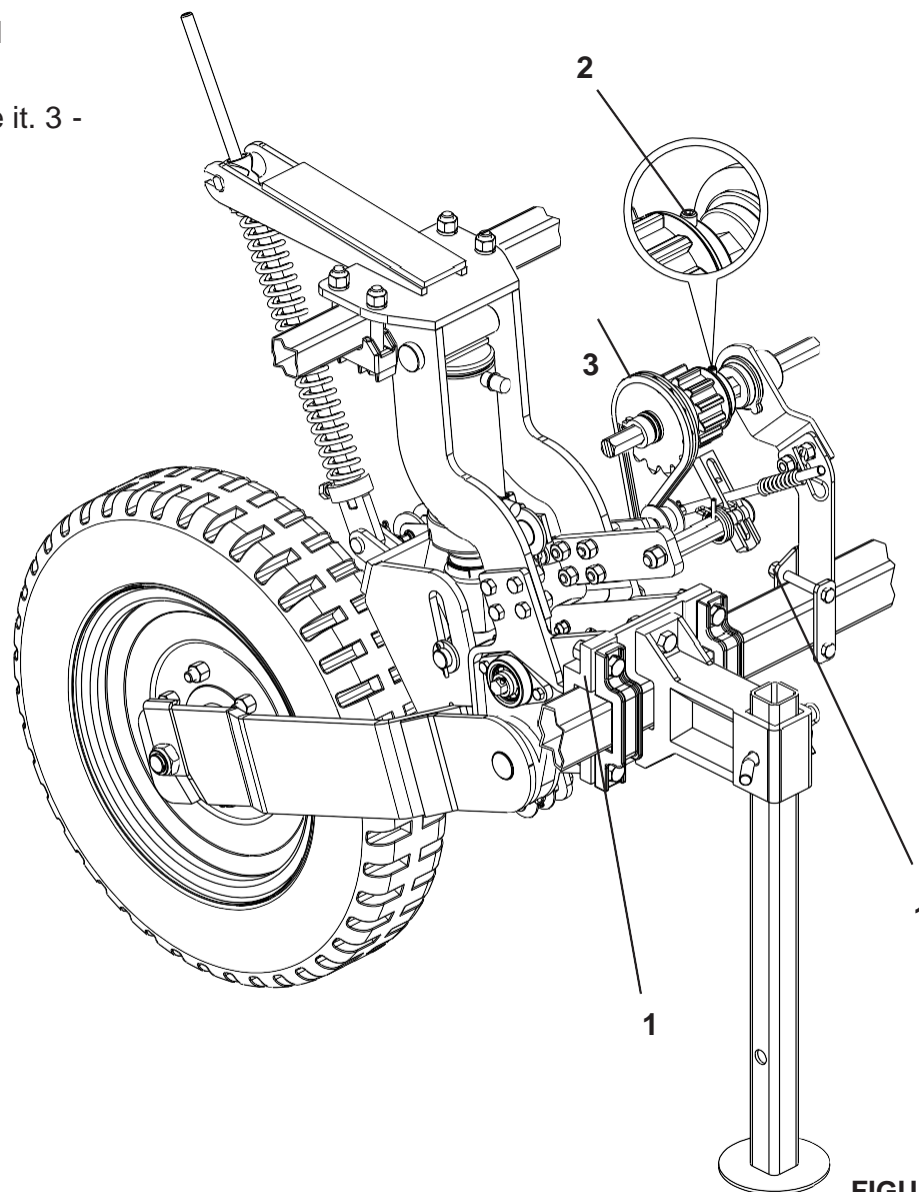

FIGURE 16



IMPORTANT

The minimum spacing between the wheel set lines is 450mm.

- If there is the need for removal of the seed axis (14), tighten the transmission chain (15) through the stiffeners (16). **FIGURE 17**

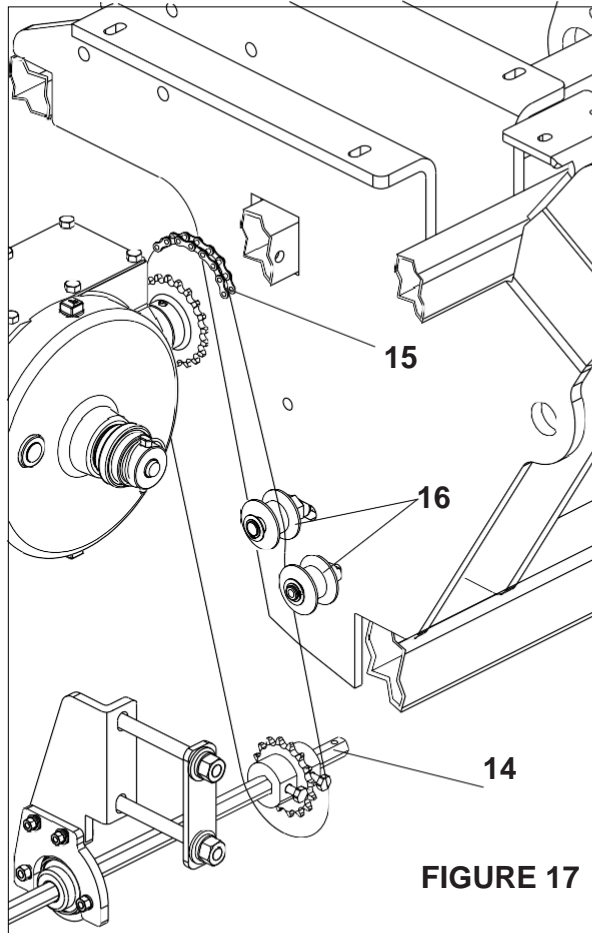

IMPORTANT

Note the alignment between the gears.

1 - Remove the fertiliser hose (17) of the lines that have been removed, close the output of the fertiliser tank with the cap (18).
2 - Close the entrance of the fertiliser inside the tank by placing the cover (19). **FIGURE 18**

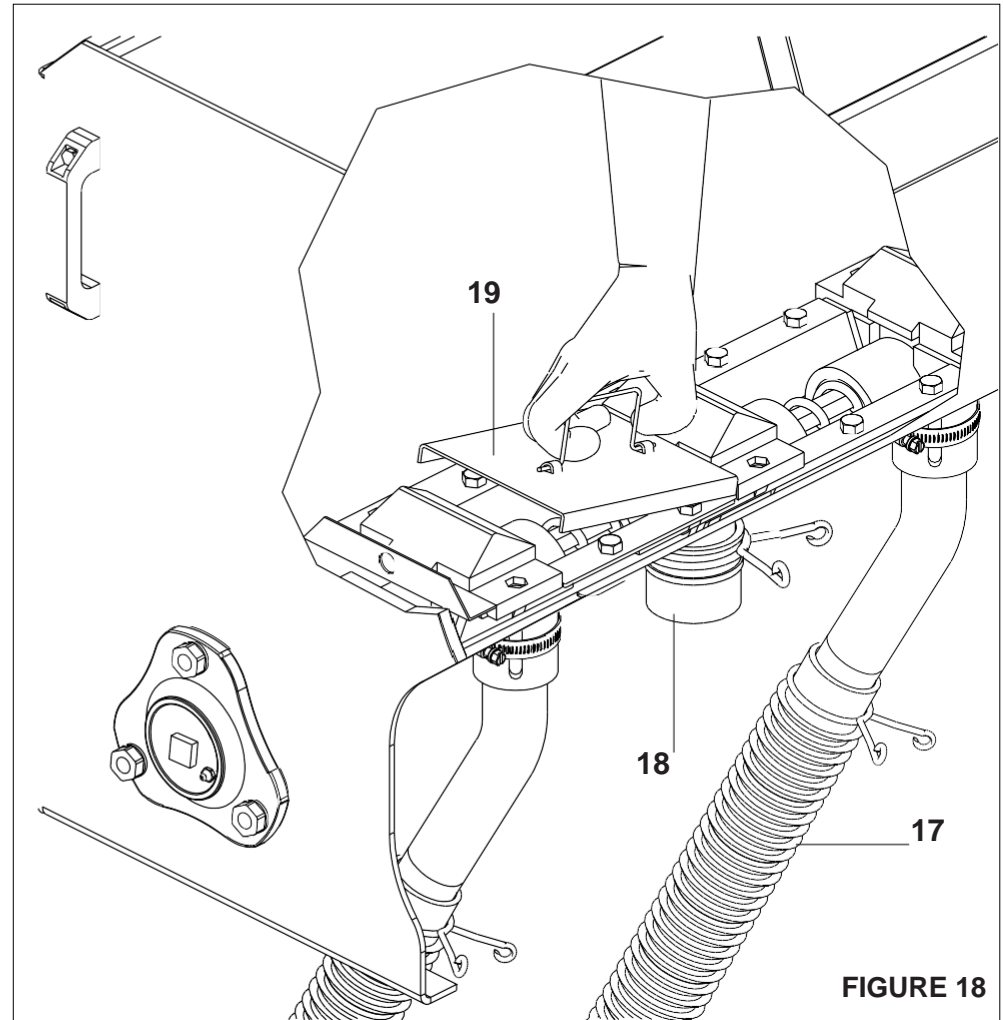

08 - TAILPIECE

SYSTEM WITHOUT TAILPIECE

- SLA *Speed Box Air* 2500. (FIGURE 19)

- The seeder model 2500 is only provided without a tailpiece, as follows;
- 1 - The transmission system comprises shafts for the distribution of fertiliser and seeds, which are driven by two *Speed Boxes*, one for fertiliser and another for seeds.

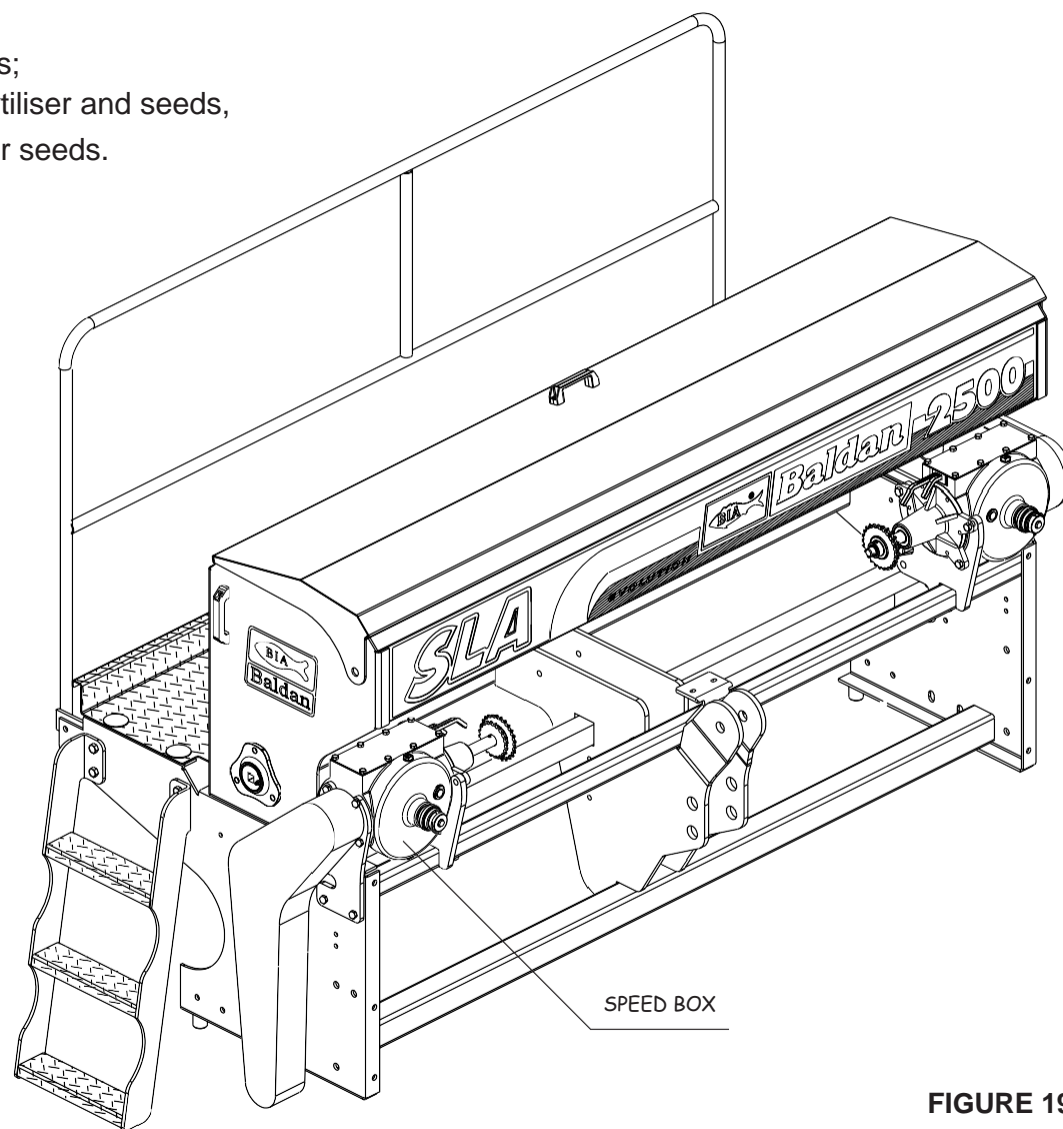

FIGURE 19

SYSTEM WITHOUT TAILPIECE

- **SLA Speed Box Air 3000** without tailpieces. **(FIGURES 20)**

- The seeder acquired without a tailpiece system does not have some accompanying parts, as follows;

2 - On the machine sides, note that there is no lever to disarm and reset the ratchet, the holding plate and compensating bearings. According to "Detail A".

3 - In the front of the machine, two **Speed Boxes** are eliminated. According to details B and C.

FIGURE 20

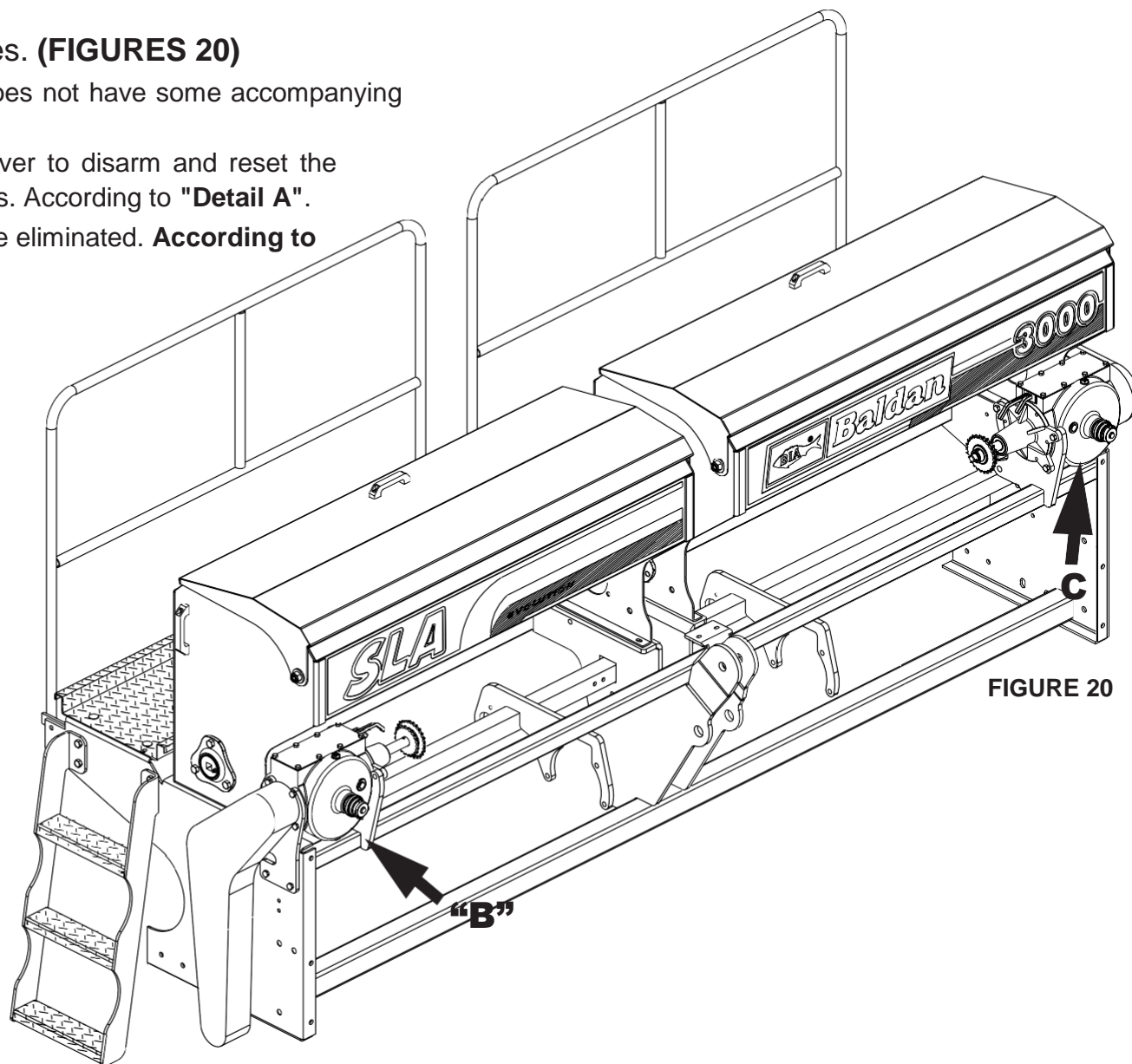
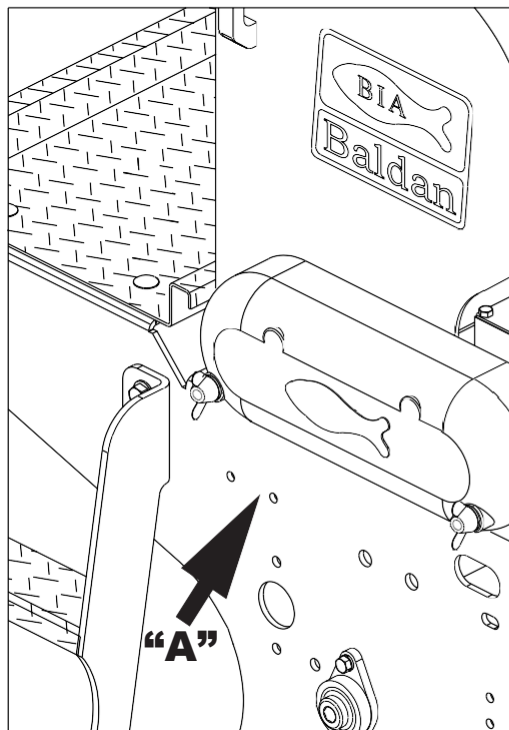

FIGURE 20

SYSTEM WITH TAILPIECE

- SLA Speed Box Air 3000 with tailpieces

- The seeder purchased with a tailpiece system is equipped with the attached parts, as follows;

4 - **Speed Box** (1), lever (2) to disarm and reset of the ratchet, plate (3) and compensating bearings (4). **FIGURES 21**

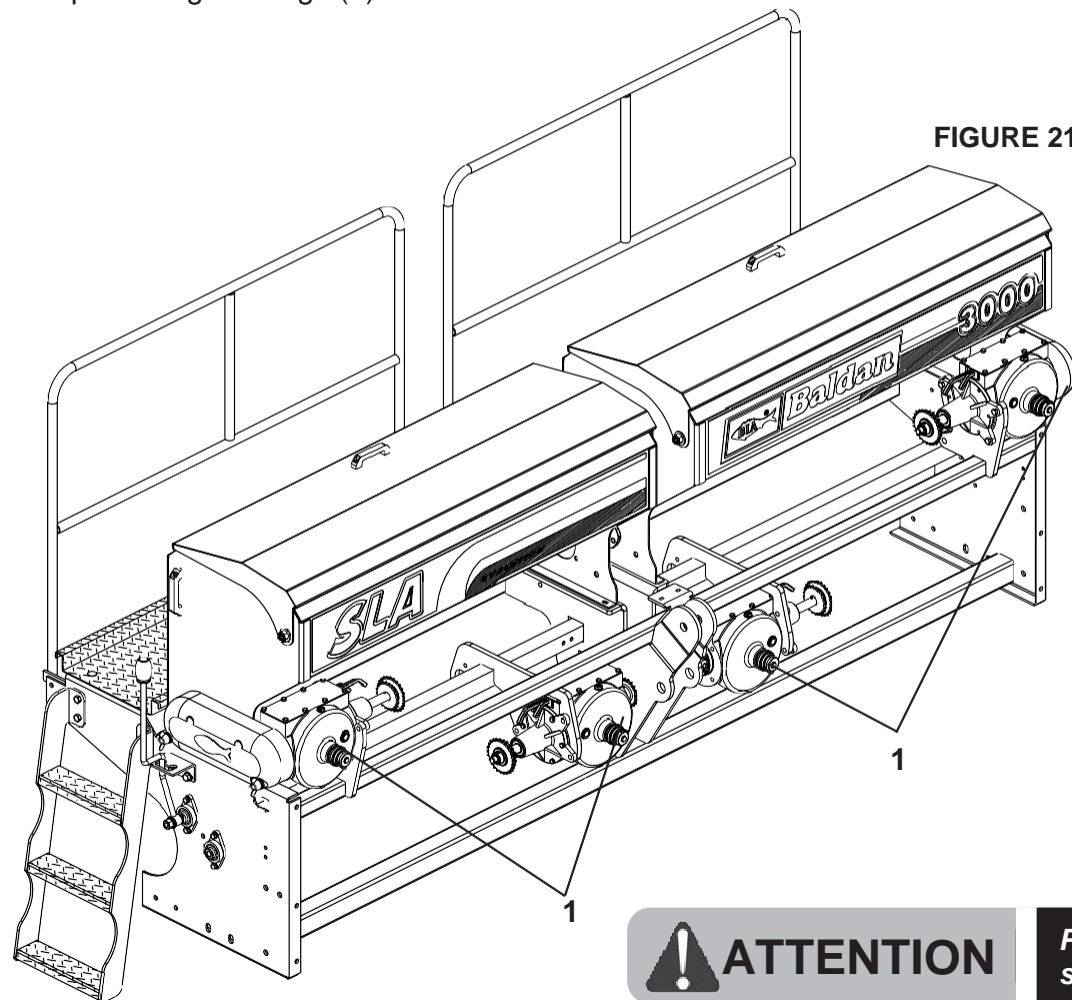

FIGURE 21

5 - The handle (2), when manually actuated allows the tailpiece with only half of the seeder.

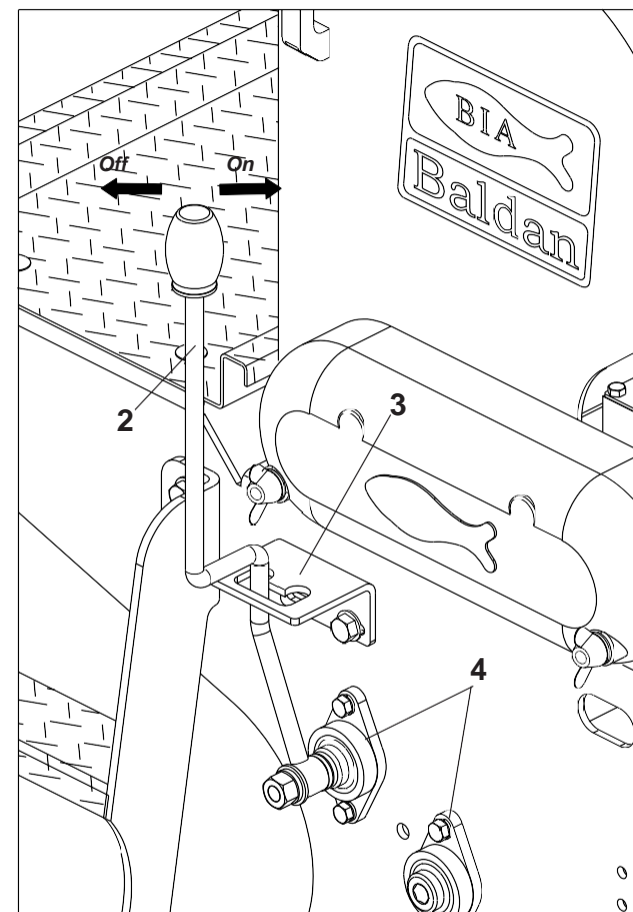

FIGURE 21



ATTENTION

Perform the disarming and resetting operation of the ratchet with the seeder stationary.

ADJUSTING THE LINE MARKERS (FIGURE 22)

1 - The regulating of the line markers is important to obtain evenly spaced planting, making so that the edge line of the seeder is at the same spacing as the last planted line, facilitating future operations.

2 - To adjust the line markers, one should know the spacing between lines, the number of lines to be used in the operation and the front gauge of the tractor. Use the formula below, followed by an example.

Example: For planting with 7 lines in the seeder, a spacing of 0.45 m and front gauge of the tractor at 1.73 m, determine:

3 - Formula:
$$D = \frac{E \times (N+1) - B}{2}$$

Solve:
$$D = \frac{0,45 \times 8 - 1,73}{2}$$

$$D = 0.935 \text{ meters}$$

WHERE:

- E = Line spacing
- N = Number of lines of the seeder
- B = Front tractor gauge
- D = Marker distance

4 - Set the line marker disc at 0.935 m to the centre of the first planting line.

5 - Line markers are alternating, one lowers after the other, so if during planting before the end of the line there is the need to stop work, engage the piston so that the seeder goes up and down twice to continue working with the marker on the right side.

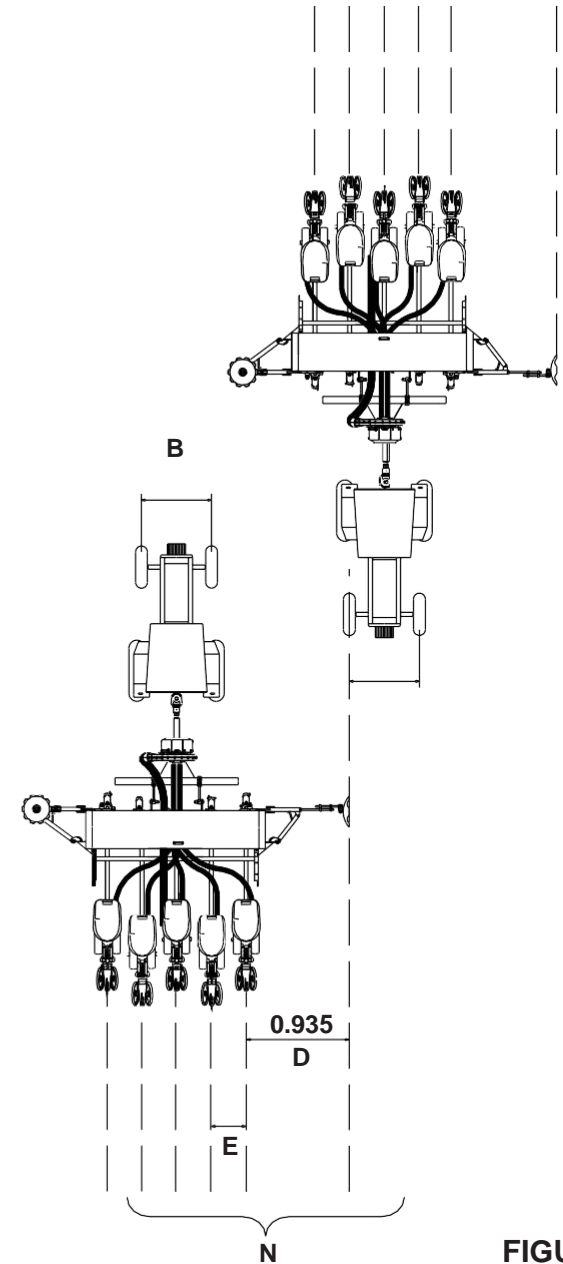

FIGURE 22

9 - SEED ADJUSTMENT (FIGURES 23/24)

PNEUMATIC SEEDS DISTRIBUTION SYSTEM (PNEUMATIC DISPENSER)

Seeders leave the factory with the dispensers mounted with a disc for soy. For changing the type of seeds, eg corn, one should proceed as follows:

- 01 The pneumatic dispenser comprises a cap, the rotor and perforated stainless steel disc, forming an assembly called a vacuum chamber.
- 02 - For assembly or replacement of perforated stainless steel discs, release the pulleys (1), distancing the pneumatic dispenser cover (2), remove the perforated stainless steel disc (3) by disengaging it. Making use of a tool (4), rotate it in the direction of the system operation until the perforated stainless steel disc is completely released, as shown in detail "A" of **FIGURE 23**.
- 03 - After replacing the stainless steel perforated disc, repeat operations as shown in **FIGURE 24**, in the reverse direction.

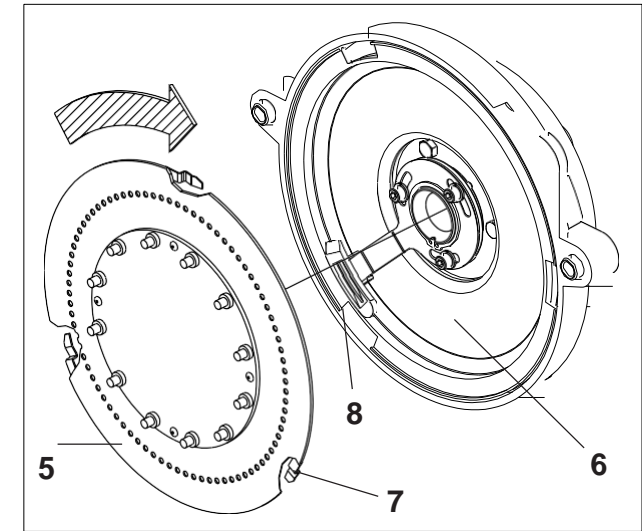

FIGURE 24

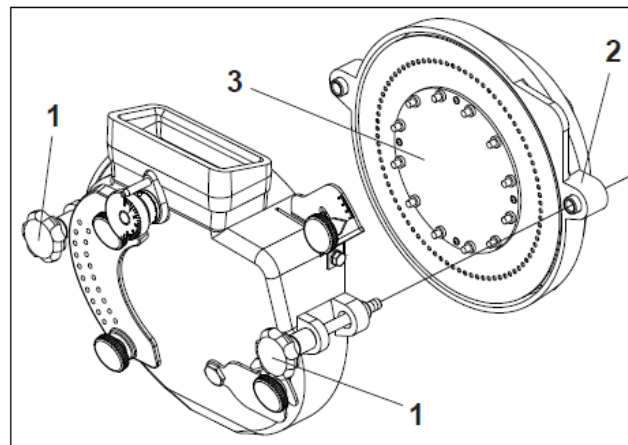

FIGURE 24



ATTENTION

Make sure that the hooks of the perforated stainless steel disc attached to the slots of the rotor, otherwise the discs will function with friction on other parts.



ATTENTION

When reassembling the lid, do not excessively tighten the handles (1), as they may be damaged.

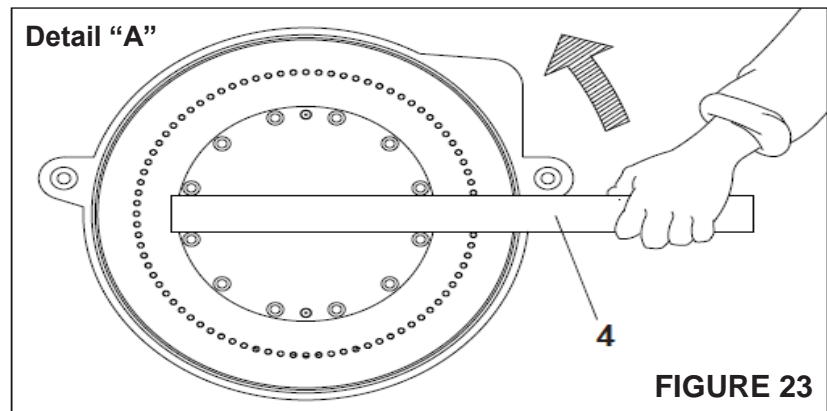

FIGURE 23

- 04 Place the desired perforated stainless steel disc (5) in the rotor (6) through the hooks (7) on the disc itself, securing it on the three slots (8) of the rotor. According to **FIGURE 24**.

DISTRIBUTORS TEST

- 01 - Before you start checking the distributors, make sure the mounted disc is the appropriate disc for the desired planting.
- 02 - Lift the first line and put seeds in its tank.
- 03 - Activate the turbine and regulate the vacuum level.
- 04 - Move a few meters with the seeder and check on the screen if the dispenser is properly regulated, that is, if all the holes in the perforated stainless steel disk are filled correctly. Otherwise, regulate the seeds limiter and the graduated regulator, as shown below:
- 05 - If cases of dual distribution or failure occur, check the adjustment of the limiter and the vacuum level.
- 06 - When the setting is correct, do this for the remaining distributors.

CULTIVATION EXCHANGE

- 07 - Fully close the output of the plastic tank through the plate (1) **FIGURE 25.**
- 08 - Then open the discharge output (2) by turning the pin (3), as per details "A" and "B" of **FIGURES 26.**
- 09 - Through the handle (4) remove the front cover (5), observing detail "C" of **FIGURE 27** how the dispenser leaves the factory. For very large seeds, eg corn-sieve 24, remove the internal limiter (8), by doing the following:

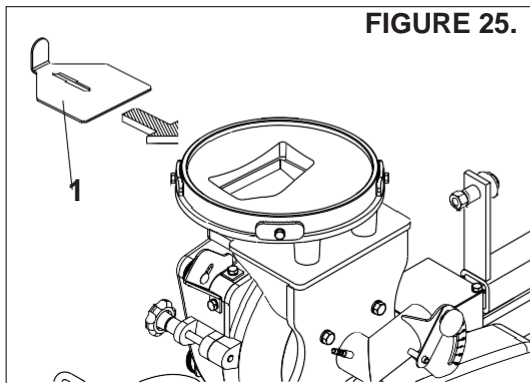

- 10 - Loosen the screw (6) and washer (7) to remove the internal stop (8). then close the cover (5) by the handle (4) and then open the
- 11 - flow exit through plate (1) again.

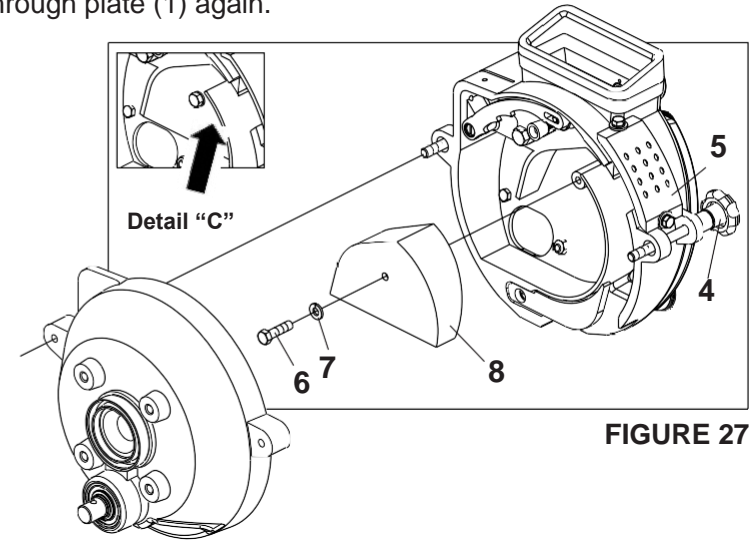

IMPORTANT

The pneumatic dispenser leaves the factory with the internal limiter assembled. Carry out the procedure above whenever you are planting with very large seeds.

Detail "A"

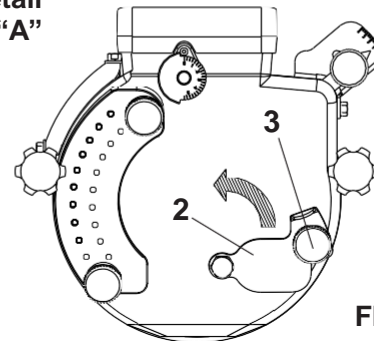

Detail "B"

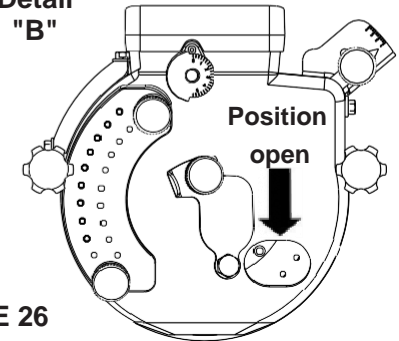
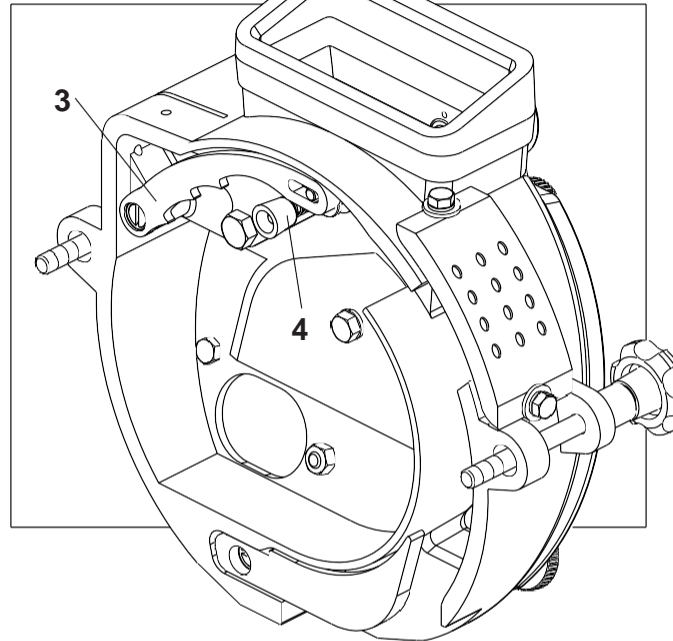
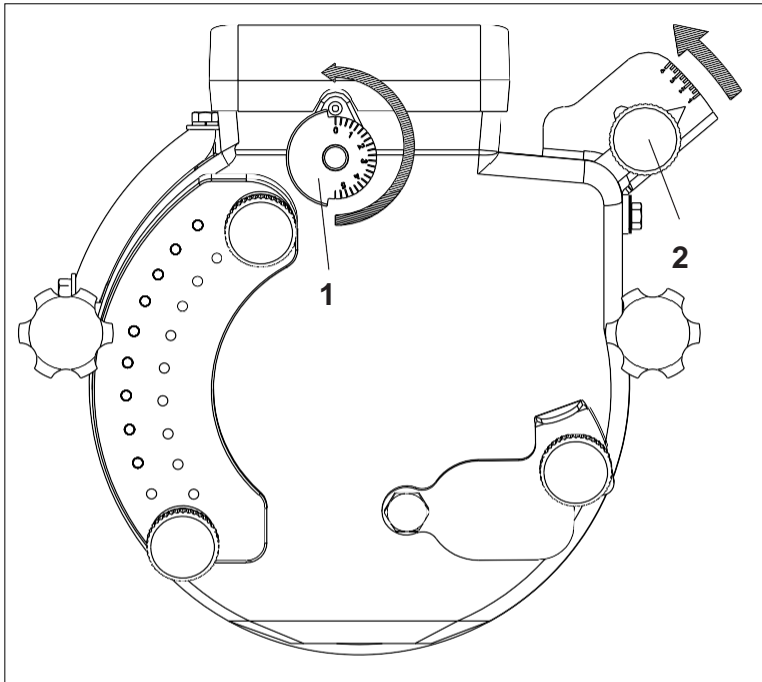

FIGURE 26

SEED LIMITERS ADJUSTMENT (FIGURES 28)

12 - Adjust the distributor of the dispenser according to the size of the seed, through limiters (1) and (2). Thus getting the desired settings of the internal parts (3) and (4) **FIGURES 28**.



FIGURES 28

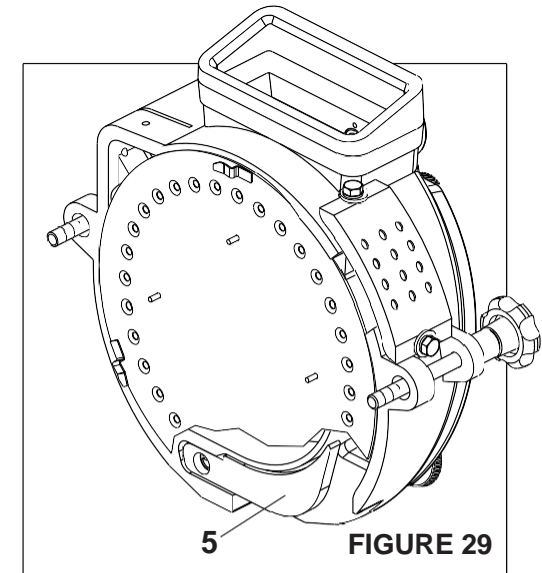

FIGURE 29

- 13 - The number of holes of the discs, as well as the diameter of them, varies according to the desired amount, the specific weight and size of the seeds to be distributed.
- 14 - Discs with a diameter of larger holes should be used for larger seeds. The treated seeds should follow the product manufacturer's instructions.
- 15 - The working speed varies according to the type of crop.
- 16 - The ratio of the disc rotation can be altered by selecting the Speed Box levers, thus obtaining the desired spacing between seeds, according to **tables 6 and 7, pages 29 and 30**.
- 17 - The pneumatic dispenser is provided with a scraper (5), which has the function of performing cleaning by avoiding obstruction thereof with straw, seed hulls, etc. **FIGURE 29**.



IMPORTANT

We recommend the use of graphite powder and/or industrial talc along with the seed, whenever filling the tank. After treatment of the seeds, they should not adhere to each other, to avoid faults in the distribution.

TABLE 03

Type of crop	Speed
Corn / Sunflower	5 to 6 km/h
Beans / Cotton without lint / Sorghum / Pea	km/h
Soybean	km/h

VIEWING OF SEEDS (FIGURES 30/31)

- Two transparent acrylic displays mounted over the windows of the dispenser cover allow the viewing of seeds and consequently the best system for regulating the planting of each crop: corn, sorghum, soybean, sunflower, beans, cotton, etc.

19 - View the operation of the distribution system through the acrylic display (1) and the acrylic lid (2).

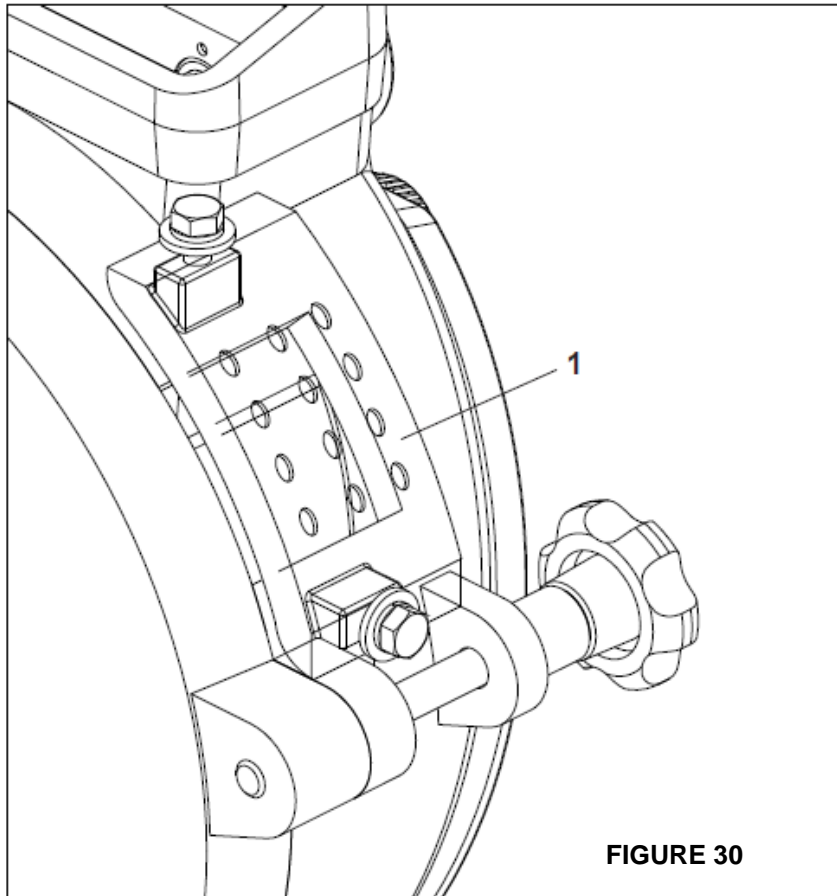

FIGURE 30

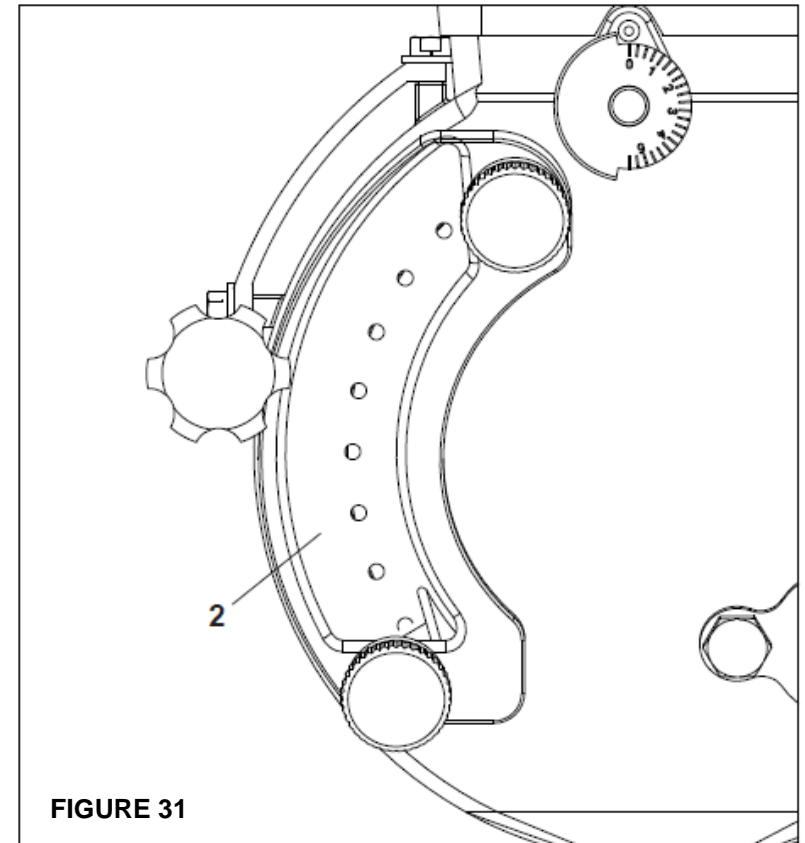

FIGURE 31

TABLE 04

Type of crop	Qty. of discs. Holes	Diameter hole in mm
Corn	32	5
Soybean	75	4,5
Pea / Sunflower Cotton	48	3,0
Sorghum	48	2,0
Beans	56	4,5
Beans (large)	48	5,0

VACUUM ADJUSTMENT (FIGURES 32/33).

- 20 The turbine must generate a determined negative pressure (vacuum) depending on the specific weight of the seed to be used, and should be set as follows:
- 21 - Place the turbine in rotation by the **TDP** of the tractor, which must operate at a constant 540 rpm.
- 22 - Check the vacuum generated that is indicated in **mbar (millibars)** through the vacuum gauge (1); introducing it through the hose on the inlet pipe (2) of the planting line (**FIGURES 32**).
- 23 - In order to increase the vacuum, release the knob (3) by moving it to the desired number in the increasing direction and to decrease the vacuum proceed in reverse. Detail "A" (**FIGURE 33**).
- 24 - The vacuum should be adjusted according to the type of crop, as per **TABLE 05** below:

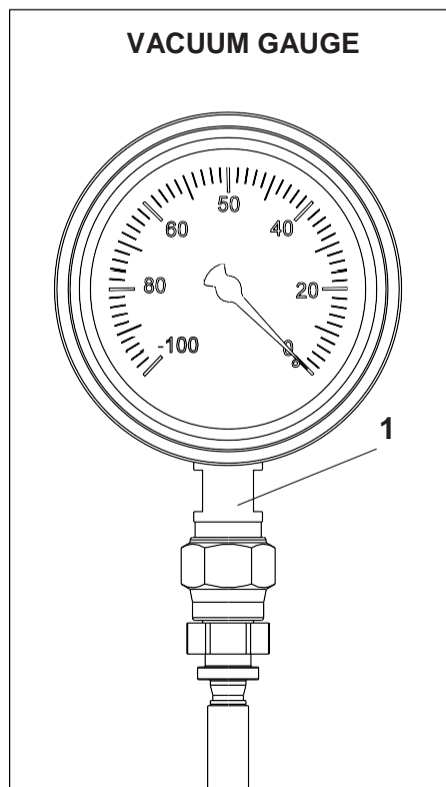

FIGURES 32

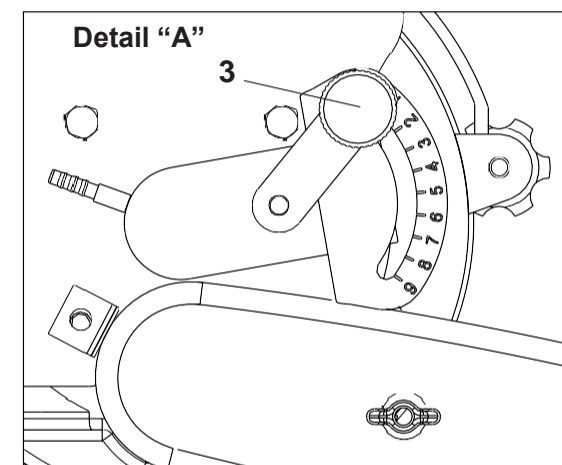
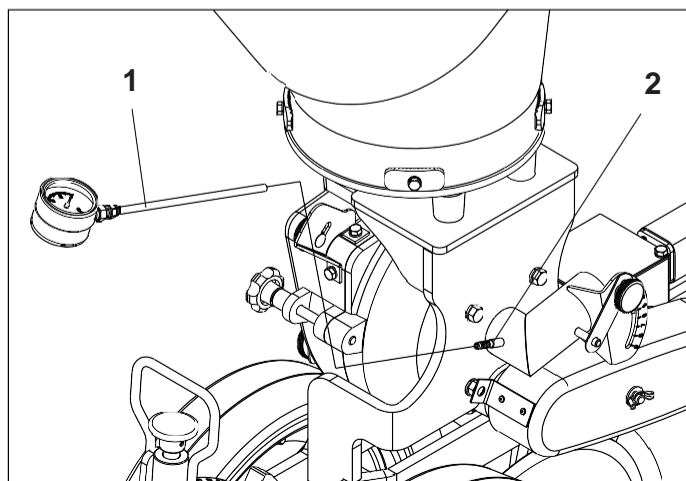

FIGURE 33

TABLE 05

TYPE OF CROP	VACUUM LEVEL
Corn / Bean	70 to 80 mbar
Soybean	60 to 80 mbar
Cotton without lint	50 to 60 mbar
Sunflower / Sorghum	40 to 50 mbar

SPEED BOX (FIGURE 34)

1 - The seeders are equipped with the gear system *Speed Box*, which drives the distribution system with simple adjustments, ensuring fast rotation changes.

2 - For seed setting, select the desired amount in the tables and check the corresponding combination of the cursors (1). Example: position **F 2** indicates that the cursor with letters must be in position "F" and the cursor with numbers must be in the "2" position, according to the detail of (FIGURE 34)

3 - To move the cursors, remove the lock (2), pull the handle (3), then set them. At the end of the combination, return the knob (3) and replace the lock (2).

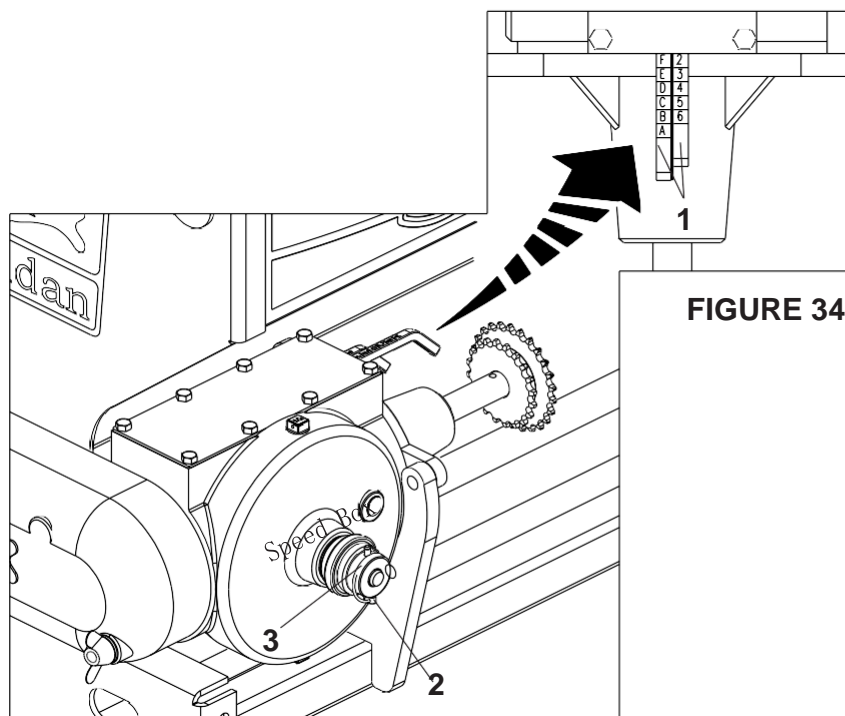

FIGURE 34

10 - ADJUSTING FOR SEED DISTRIBUTION (FIGURE 35)

4 - The seed adjustment is made by the *Speed Box*. For more settings reposition the chain on the motor gears "A" and moved "B".

5 - After carrying out the repositioning, check the chain tension.

6 - The tensioner (1) is provided with a torsion spring for increased flexibility, if increased pressure in the tensioner is necessary, rotate the gear (2) passing the spring latch (3) to the other tooth of the gear.

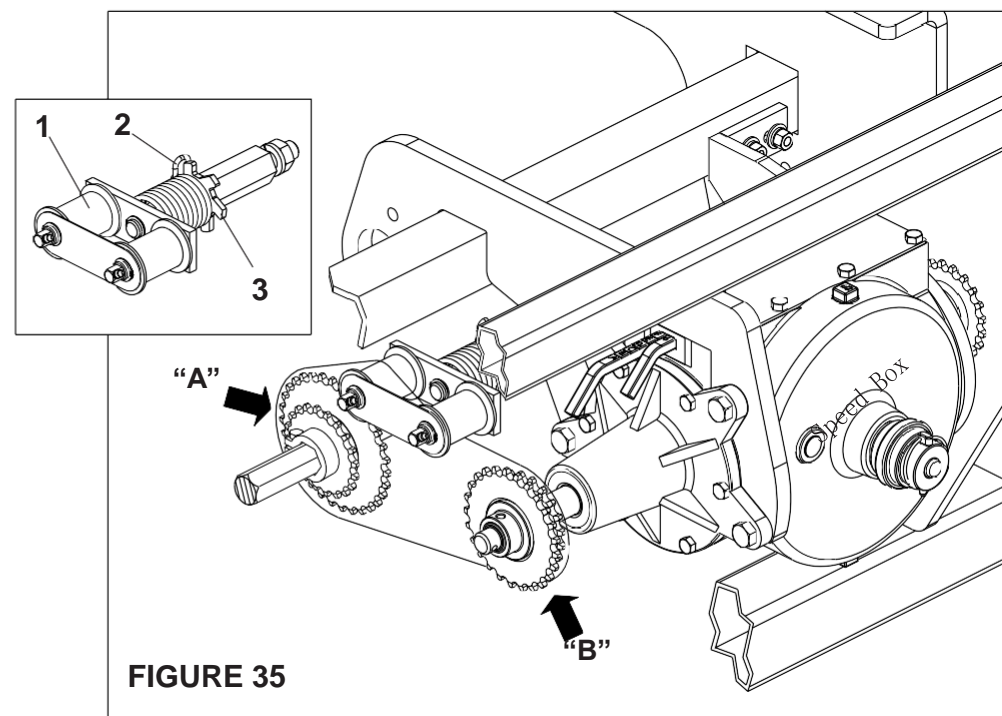

FIGURE 35

Seed distribution table per linear meter of the Seeder SLA *Evolution* 2500/3000 *Speed Box*

Ratchet shaft output gear	20		Input gear of speed Box		25
	Combination	32	Number of holes of the Disc		75
			48	56	
F - 1	2,0	3,1	3,6	4,8	
F - 2	2,3	3,5	4,0	5,4	
E - 1	2,6	3,8	4,5	6,0	
F - 3	2,6	4,0	4,6	6,2	
E - 2	2,9	4,3	5,0	6,8	
D - 1	3,1	4,6	5,4	7,2	
F - 4	3,1	4,6	5,4	7,2	
E - 3	3,3	4,9	5,8	7,7	
D - 2	3,5	5,2	6,1	8,1	
C - 1	3,6	5,4	6,3	8,4	
F - 5	3,7	5,5	6,5	8,6	
E - 4	3,8	5,8	6,7	9,0	
D - 3	4,0	5,9	6,9	9,3	
C - 2	4,0	6,1	7,1	9,5	
B - 1	4,1	6,1	7,2	9,6	
A - 1	4,6	6,9	8,1	10,8	
A - 2	5,2	7,8	9,1	12,2	
B - 3	5,3	7,9	9,2	12,3	
C - 4	5,4	8,1	9,4	12,6	
D - 5	5,5	8,3	9,7	13,0	
E - 6	5,8	8,6	10,1	13,5	
A - 3	5,9	8,9	10,4	13,9	
B - 4	6,1	9,2	10,8	14,4	
C - 5	6,5	9,7	11,3	15,1	
D - 6	6,9	10,4	12,1	16,2	
A - 4	6,9	10,4	12,1	16,2	
B - 5	7,4	11,1	12,9	17,3	
C - 6	8,1	12,1	14,1	18,9	
A - 5	8,3	12,4	14,5	19,4	
B - 6	9,2	13,8	16,1	21,6	
A - 6	10,4	15,6	18,2	24,3	

Table - 06

Seed distribution table per linear meter of the Seeder SLA Evolution 2500/3000 Speed Box

Ratchet shaft output gear	25		Input gear speed Box		20
	Number of holes in the Disc				
Combination	32	48	56	75	
F - 1	3,2	4,8	5,6	7,5	
F - 2	3,6	5,4	6,3	8,4	
E - 1	4,0	6,0	7,0	9,4	
F - 3	4,1	6,2	7,2	9,6	
E - 2	4,5	6,8	7,9	10,6	
D - 1	4,8	7,2	8,4	11,3	
F - 4	4,8	7,2	8,4	11,3	
E - 3	5,1	7,7	9,0	12,1	
D - 2	5,4	8,1	9,5	12,7	
C - 1	5,6	8,4	9,8	13,1	
F - 5	5,8	8,6	10,1	13,5	
E - 4	6,0	9,0	10,5	14,1	
D - 3	6,2	9,3	10,8	14,5	
C - 2	6,3	9,5	11,0	14,8	
B - 1	6,4	9,6	11,2	15,0	
A - 1	7,2	10,8	12,6	16,9	
A - 2	8,1	12,2	14,2	19,0	
B - 3	8,2	12,3	14,4	19,3	
C - 4	8,4	12,6	14,7	19,7	
D - 5	8,6	13,0	15,1	20,3	
E - 6	9,0	13,5	15,8	21,1	
A - 3	9,3	13,9	16,2	21,7	
B - 4	9,6	14,4	16,8	22,5	
C - 5	10,1	15,1	17,6	23,6	
D - 6	10,8	16,2	18,9	25,3	
A - 4	10,8	16,2	18,9	25,3	
B - 5	11,5	17,3	20,2	27,0	
C - 6	12,6	18,9	22,1	29,5	
A - 5	13,0	19,4	22,7	30,4	
B - 6	14,4	21,6	25,2	33,8	

Table - 07

FERTILISER DISTRIBUTION SYSTEM METALLIC TANK (FIGURE 36)

1 - The floating spiral fertiliser distribution system consists of a shaft placed in the bottom of the fertiliser tank, which when begins turning, the fertiliser involves the shaft, carrying it to the outputs, eliminating intermediate bearings.

2 - When determining the number of lines and the desired spacing, connect the hoses (1) to the fertiliser spout (2), making the connection of hoses that are close to the lines, preventing them from getting folded or bent. For better alignment of the hoses if necessary use the spout with grade (3) according to **FIGURE 36**.

3 - The outputs that will not be used should be closed with the covers (4) in the tank and the cap (5) on the external outputs, this will prevent fine particles of fertiliser from falling on the seeder.

4 - The fertiliser dispenser system of the floating spiral type has a number of safety outputs that, when the fertiliser enters the dispenser and any output is clogged, it will begin to leak through the safety outputs "A", ensuring the functioning to the system without damaging it. If this occurs, carry out the cleaning of the dispenser spout located on the double disc or shank, because blockages may occur due to roots, plastic pieces or other objects.

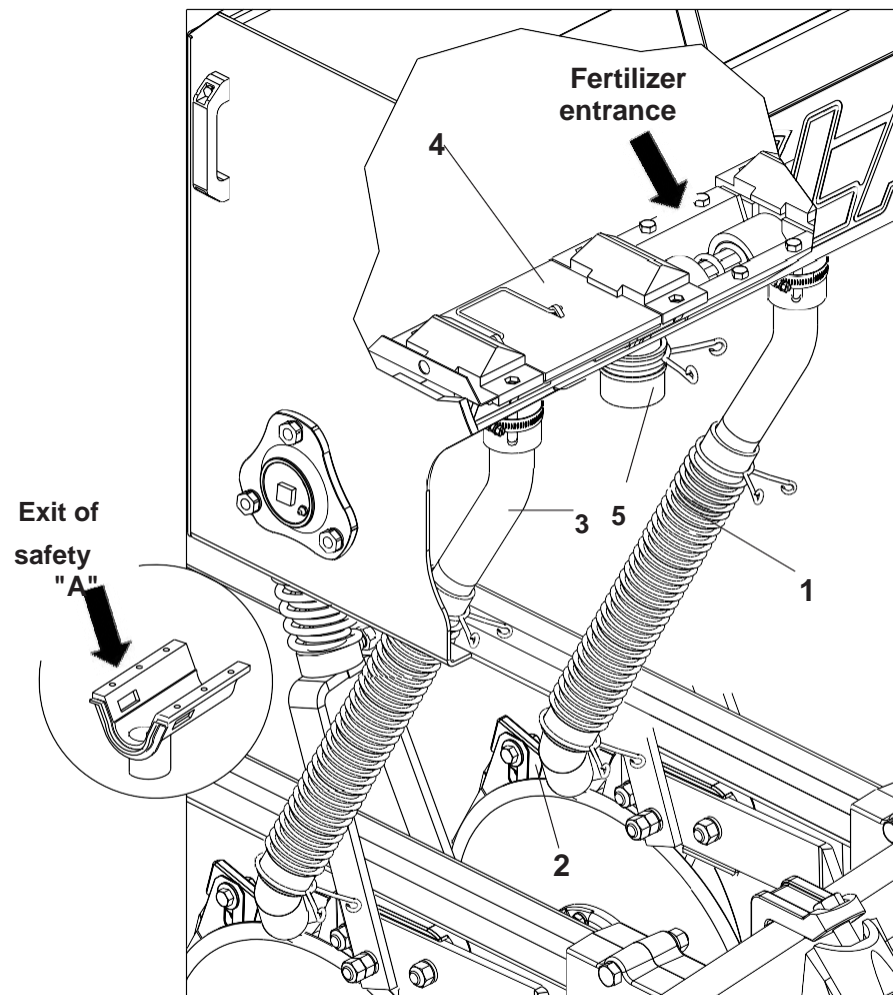

FIGURE 36



Periodically remove the plugs (5) and proceed with cleaning on their outputs. When the fertiliser has impurities or is moist, clean more often.

FERTILISER DISTRIBUTION SYSTEM POLYETHYLENE TANK (FIGURES 37)

- INDEPENDENT SYSTEM

5 - To conduct the fertiliser distributor to the ground, connect the hoses (1) on the distribution spouts (2) of the fertiliser, preventing them from getting bent or folded, **FIGURES 37**.

6 - The individual distribution system has a safety exit **detail "A"** that, when inserting the fertiliser in the dispenser and the hose is clogged, it will begin to leak fertiliser through this safety exit, ensuring the operation of the system without damaging it. If this occurs, proceed to clean the dispenser until the end of the hose next to the shank or double disc, because the clogging of the system can occur by roots, pieces of plastic and other objects.

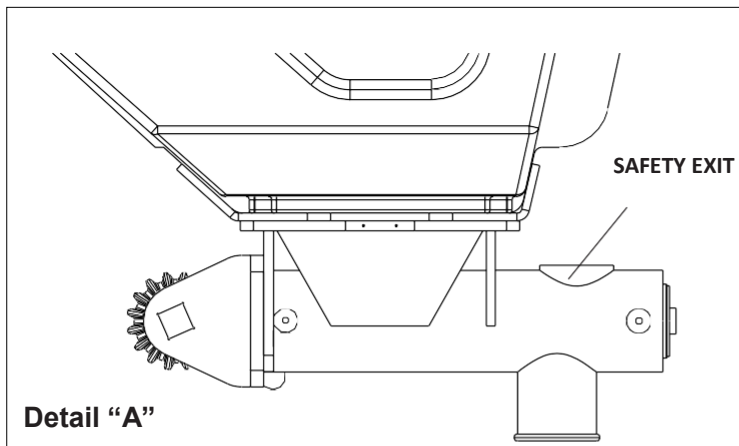
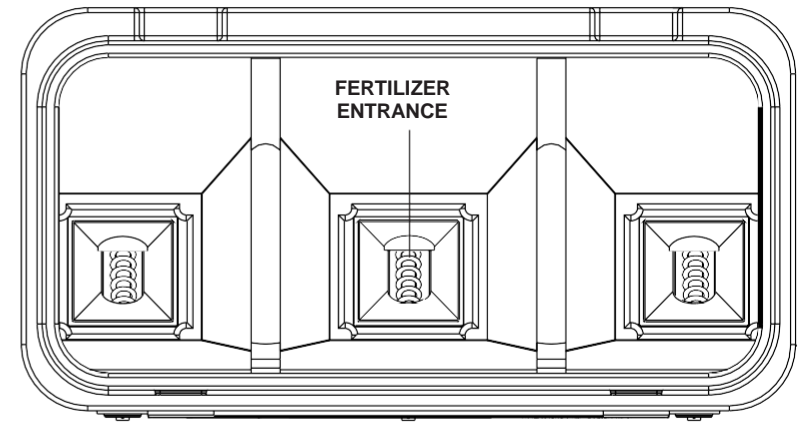
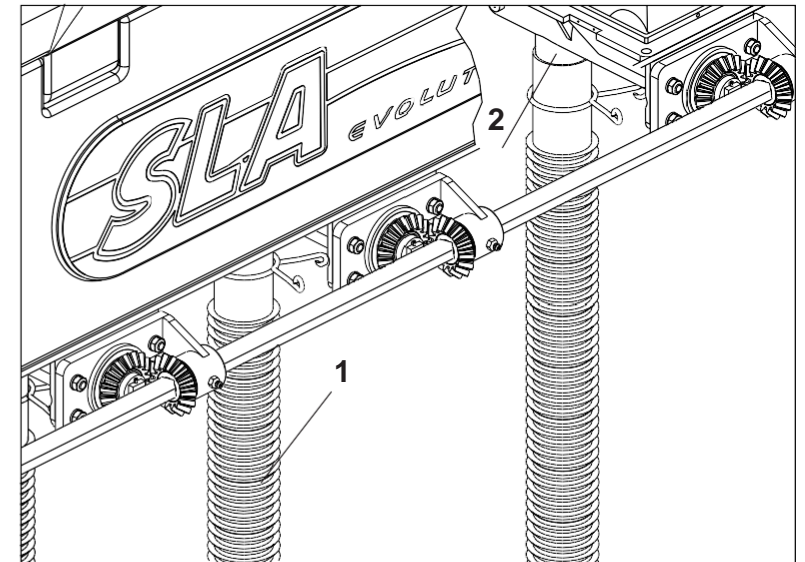

FIGURE 37



FIGURES 37



IMPORTANT

Check distributors and hoses daily, and if necessary, proceed to clean the exits thereof.

SPEED BOX (FIGURE 38)

- 1 - The seeders are equipped with the gearbox speed system **Speed Box**, which triggers the distribution system, with simple adjustments, ensuring practical and quick rotation changes.
- 2 - For settings of fertiliser, select the desired amount in the tables and check the corresponding combination of cursors (1). Example: position **F 2** indicates that the cursor with letters must be in position "**F**" and the cursor with numbers must be in position "**2**", according to **FIGURE 38**.
- 3 - To move the cursor, remove the lock (2), pull the handle (3), then set them. At the end of the combination, return the knob (3) and replace the lock (2).

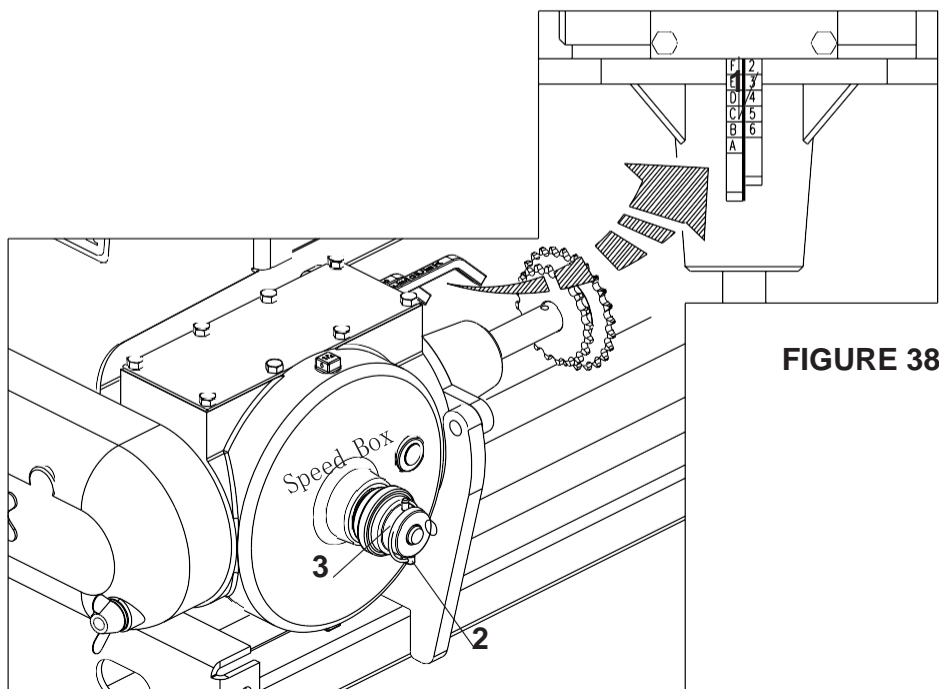

FIGURE 38

11 - ADJUSTING FOR FERTILISER DISTRIBUTION (FIGURE 39)

- 4 - The regulation of the fertiliser is made through the **Speed Box** gearbox. For more settings reposition the chain on the motor gears "**A**" and moved "**B**".
- 5 - After carrying out the repositioning of the gears, check the chain tension.
- 6 - The tensioner (1) is provided with a torsion spring for increased flexibility, if increased pressure in the tensioner is necessary, rotate the gear (2) passing the spring latch (3) to the other tooth of the gear.

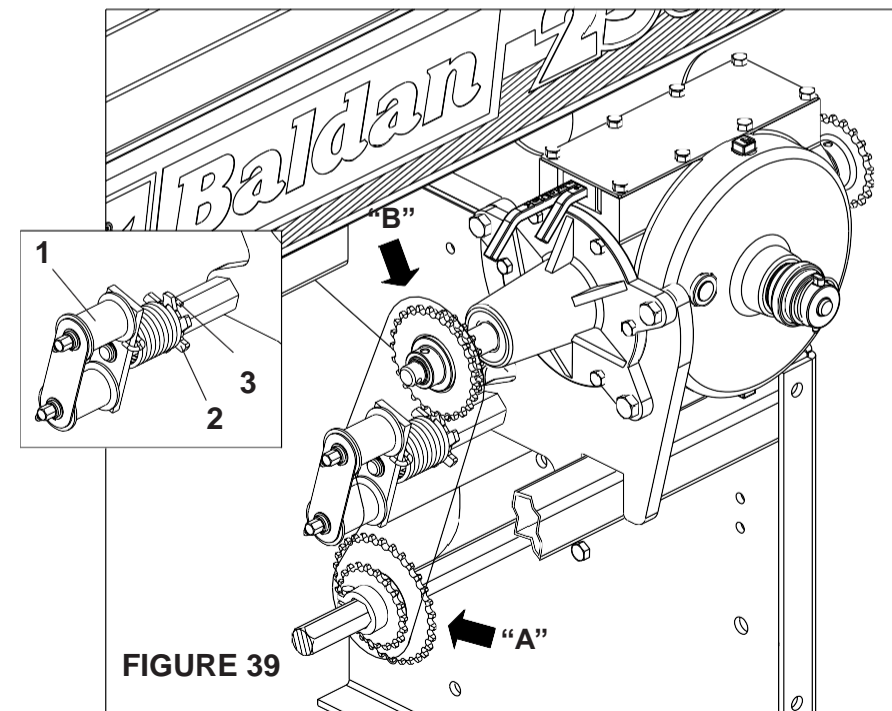

FIGURE 39



Fertiliser Distribution Table of Seeder *SLA evolution* 2500/3000 [kg / ha] - Table prepared using spring Step 2" for fertiliser distribution.

Ratchet shaft output gear	20	Input gear of Speed Box											31
		Spacing between lines [mm]											
Combination	Grammes / 50 m	415	430	450	500	550	600	650	700	750	800	850	900
F - 1	332	160	154	148	133	121	111	102	95	89	83	78	74
F - 2	374	180	174	166	149	136	125	115	107	100	93	88	83
E - 1	415	200	193	184	166	151	138	128	119	111	104	98	92
F - 3	427	206	199	190	171	155	142	131	122	114	107	100	95
E - 2	467	225	217	208	187	170	156	144	133	125	117	110	104
D - 1	498	240	232	221	199	181	166	153	142	133	125	117	111
F - 4	498	240	232	221	199	181	166	153	142	133	125	117	111
E - 3	534	257	248	237	213	194	178	164	152	142	133	126	119
D - 2	560	270	261	249	224	204	187	172	160	149	140	132	125
C - 1	581	280	270	258	232	211	194	179	166	155	145	137	129
F - 5	598	288	278	266	239	217	199	184	171	159	149	141	133
E - 4	623	300	290	277	249	226	208	192	178	166	156	147	138
D - 3	640	309	298	285	256	233	213	197	183	171	160	151	142
C - 2	654	315	304	291	262	238	218	201	187	174	163	154	145
B - 1	664	320	309	295	266	242	221	204	190	177	166	156	148
A - 1	747	360	348	332	299	272	249	230	213	199	187	176	166
A - 2	841	405	391	374	336	306	280	259	240	224	210	198	187
B - 3	854	412	397	380	342	311	285	263	244	228	213	201	190
C - 4	872	420	405	387	349	317	291	268	249	232	218	205	194
D - 5	897	432	417	399	359	326	299	276	256	239	224	211	199
E - 6	934	450	434	415	374	340	311	287	267	249	234	220	208
A - 3	961	463	447	427	384	349	320	296	274	256	240	226	213
B - 4	996	480	463	443	399	362	332	307	285	266	249	234	221
C - 5	1046	504	487	465	418	380	349	322	299	279	262	246	232
D - 6	1121	540	521	498	448	408	374	345	320	299	280	264	249
A - 4	1121	540	521	498	448	408	374	345	320	299	280	264	249
B - 5	1196	576	556	531	478	435	399	368	342	319	299	281	266
C - 6	1308	630	608	581	523	475	436	402	374	349	327	308	291
A - 5	1345	648	626	598	538	489	448	414	384	359	336	316	299
B - 6	1494	720	695	664	598	543	498	460	427	399	374	352	332
A - 6	1681	810	782	747	672	611	560	517	480	448	420	396	374

Table 08

Fertiliser Distribution Table of Seeder *SLA evolution 3000* [kg / ha] - Table prepared using spring Step 2" for fertiliser distribution.

Ratchet shaft output gear		Input gear of Speed Box											
		Spacing between lines [mm]											
Combination	Grammes / 50 m	415	430	450	500	550	600	650	700	750	800	850	900
F - 1	798	385	371	355	319	290	266	245	228	213	199	188	177
F - 2	898	433	417	399	359	326	299	276	256	239	224	211	199
E - 1	997	481	464	443	399	363	332	307	285	266	249	235	222
F - 3	1026	494	477	456	410	373	342	316	293	274	256	241	228
E - 2	1122	541	522	499	449	408	374	345	321	299	280	264	249
D - 1	1197	577	557	532	479	435	399	368	342	319	299	282	266
F - 4	1197	577	557	532	479	435	399	368	342	319	299	282	266
E - 3	1282	618	596	570	513	466	427	395	366	342	321	302	285
D - 2	1346	649	626	598	539	490	449	414	385	359	337	317	299
C - 1	1396	673	649	621	558	508	465	430	399	372	349	329	310
F - 5	1436	692	668	638	574	522	479	442	410	383	359	338	319
E - 4	1496	721	696	665	598	544	499	460	427	399	374	352	332
D - 3	1539	742	716	684	615	560	513	473	440	410	385	362	342
C - 2	1571	757	731	698	628	571	524	483	449	419	393	370	349
B - 1	1596	769	742	709	638	580	532	491	456	426	399	375	355
A - 1	1795	865	835	798	718	653	598	552	513	479	449	422	399
A - 2	2020	973	939	898	808	734	673	621	577	539	505	475	449
B - 3	2052	989	954	912	821	746	684	631	586	547	513	483	456
C - 4	2094	1009	974	931	838	762	698	644	598	558	524	493	465
D - 5	2154	1038	1002	957	862	783	718	663	615	574	539	507	479
E - 6	2244	1081	1044	997	898	816	748	690	641	598	561	528	499
A - 3	2308	1112	1074	1026	923	839	769	710	659	615	577	543	513
B - 4	2394	1154	1113	1064	957	870	798	736	684	638	598	563	532
C - 5	2513	1211	1169	1117	1005	914	838	773	718	670	628	591	558
D - 6	2693	1298	1252	1197	1077	979	898	829	769	718	673	634	598
A - 4	2693	1298	1252	1197	1077	979	898	829	769	718	673	634	598
B - 5	2872	1384	1336	1277	1149	1044	957	884	821	766	718	676	638
C - 6	3142	1514	1461	1396	1257	1142	1047	967	898	838	785	739	698
A - 5	3231	1557	1503	1436	1293	1175	1077	994	923	862	808	760	718
B - 6	3590	1730	1670	1596	1436	1306	1197	1105	1026	957	898	845	798
A - 6	4039	1947	1879	1795	1616	1469	1346	1243	1154	1077	1010	950	898

Tabela 09



12 - PRACTICAL CALCULATION FOR FERTILISER AND SEEDS DISTRIBUTION

1 - Determine the spacing and the amount of fertiliser to be distributed by Bushel (Aa) or Hectare (Ha).

Example: Seeder with 450 mm spacing, to distribute 500 kg of fertiliser per hectare, use the following formula:

Formula:

$$X = \frac{E \times Q}{A} \times D$$

Resolve:

$$X = \frac{450 \times 500}{10,000} \times 50$$

$$X = 22,50 \times 50 = 1125$$

$$X = 1125 \text{ grammes at } 50 \text{ metres per line}$$

Data of the formula:

E = Spacing between lines (mm)

Q = Amount of fertiliser to be distributed [Kg]

A = Area to be fertilised [m²]

D = distance of 50 meters (test) X = Grammes of fertiliser in 50 meters

PRACTICAL TEST TO ASSESS THE QUANTITY OF FERTILISER AND SEED DISTRIBUTION.

2 - For more precision of distribution of both the seed and the fertiliser, carry out the testing for the amount to be distributed on the planting site, because for each field there is a condition.

3 - Check and keep the calibration on the tires of the seeder at 70 lb / square inch in each.

4 - Note the distance of the test in the table, we opted for 50 linear metres.

5 - Fill the tanks of the seeder at least halfway. Move a few meters outside the test area so that the seed and fertiliser fill the dispensers.

6 - Seal the output of seed spouts and place containers to collect the outputs of fertiliser. Move the tractor in the demarcated area, always at the same speed that planting will occur.

7 - After moving the marked space (fertiliser table) in the column (grammes per line of 50 meters), remove the seal of the seed spout and collect them for counting and weigh the collected fertiliser. If necessary to increase or decrease fertiliser and seed proceed through the *Speed Box*.

ADJUSTING THE LINE MARKER DISC (FIGURE 40)

8 - The line marker disc (1) has an angular adjustment marking to facilitate working of the soil. For this adjustment, loosen the nut (2) and turn the disc to the desired position.

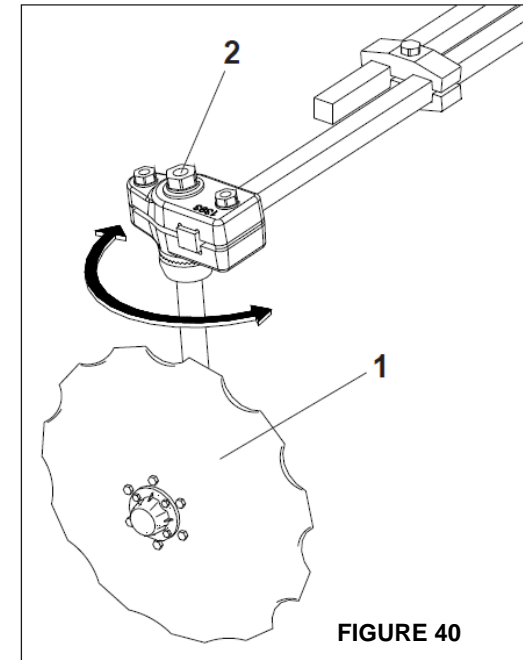

FIGURE 40

13 - DEPTH ADJUSTMENT

GROOVE OPENING AND FERTILISER POSITION IN SOIL

1 - The opening of the groove in the ground allows the fertiliser to be deposited in the following systems:

- Side fertilisation and below the seed.
- Fertilisation in the same line and below the seed.

2 - For setting the distance of the fertiliser line from the seed line, remove the spring rod (6), loosen the nuts (1), remove the housing (2) which is between the plates of the fork (3), pass it to one of the sides of the fork, put the bushings (4) between the plates of the fork and secure with screws (5) washers and nuts (1), as detailed in **(Figures 41)**, then replace the rod of the spring (6), placing the bushings (7) on the same side that was shifted to the housing, fixing with the pin (8) and lock (9).

3 - Observe the section view in the detail of **(Figures 41)**
TRENCHERS POSITION **(FIGURES 42)**

4 - The trencher has two working positions. For this adjustment remove the screw (1), articulate the trencher (2) to the lower hole and replace the screw (1).

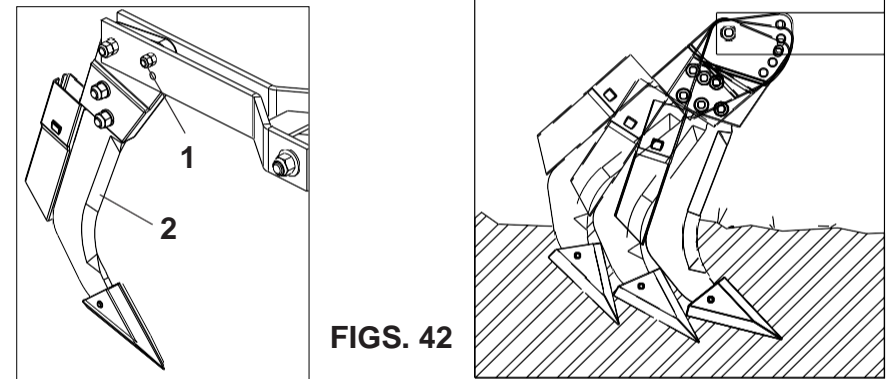
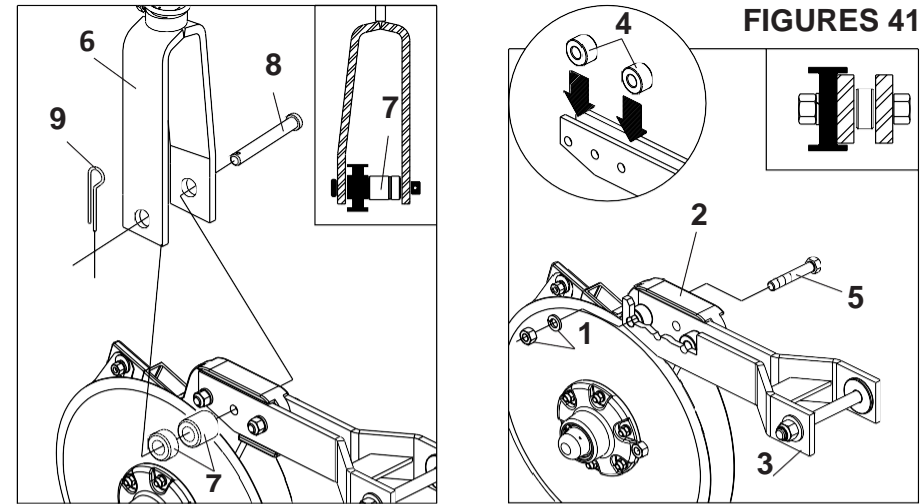

DEPTH ADJUSTMENT OF THE CUTTING DISC **(FIGURE 43)**

5 - To adjust the depth of the cutting disc (1), loosen the screws (2) and move the shaft (3) to the desired setting. Then retighten the screws (2).

6 - The spring (4) leaves the factory with the regulated pressure, do not give more pressure to it to not override the joint action of the cutting disc.



FIGURA 43

ADJUSTMENT OF THE CLEANERS DOUBLE DISCS **(FIGURE 44)**

7 - The double discs have cleaners (1) that are flexible and adjustable by means of screws (2), to remove the dirt adhering to the disks.

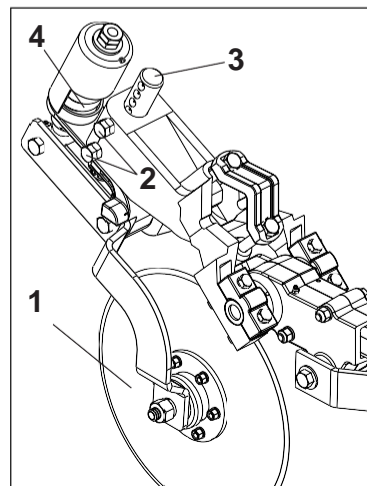
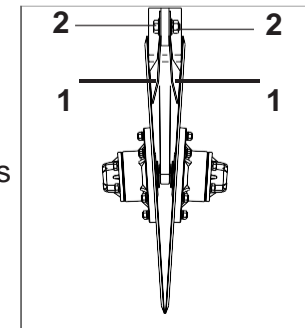

FIGURE 44

DEPTH OF SEEDS (FIGURE 45)

8 - The seed depth is made individually by depth limiting wheels. For this adjustment pull the lock pin (1) through the handle (2) and move the wheel (3) to the hole of the desired depth.

OSCILLATING DEPTH LIMITING WHEEL

9 - The oscillating depth limiting wheels have a single point of support that allows them to oscillate, if they experience any obstacle in the course of one of them or irregularities in the ground, it will rise to transpose it, immediately returning to the starting position without raising the double disc of its position.



NOTE

The settings "A" and "B" (4) provide 18 setting points, 9A and 9B, interleaved.

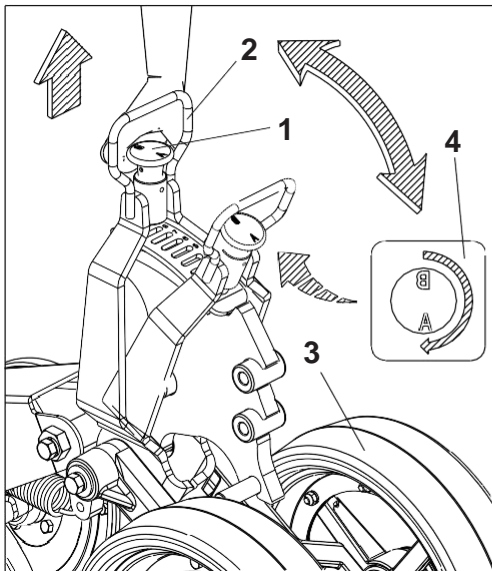

FIGURE 45

ADJUSTING THE COMPACTOR WHEEL IN "V" (FIGURES 46)

10 - The compactor wheels in "V" are intended to press the groove laterally, causing the soil to be immediately placed on the seed, avoiding too much compression, facilitating germination and plant growth.

11 - The wheel pressure (1) is made with the lever (2), which moved back will provide greater pressure on the wheels.

12 - The wheels can be tilted by the lever (3). For this adjustment loosen the screw (4) and move the lever observing the wheel position and its use:

- Position "A" (closed), puts less earth on the seed.
- Position "B" (open), puts more earth on the seed.

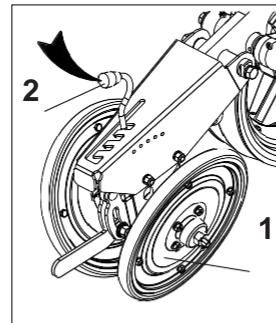

- CUT DISC FOR COVERAGE OF SEED

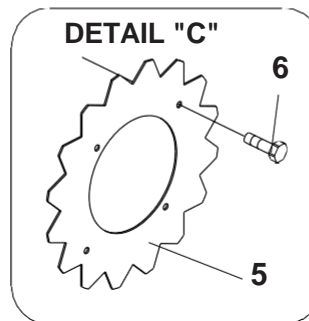

IMPORTANT: Perform the same setting for all compactor wheels and consider the type of soil, seed and planting depth, to not affect the emergence of the plantation.

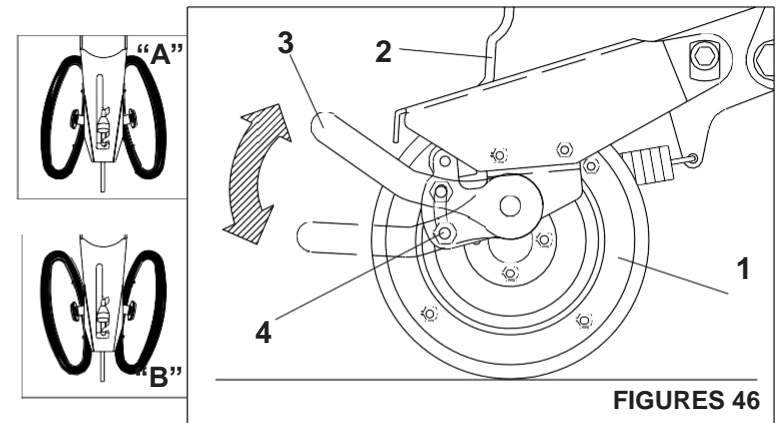

FIGURES 46

- To facilitate the replacement of earth on the seed on compacted soil, place the cut disc to cover (5) using the screw (6) on the compactor wheels in "V" (1). **Detail "C"**.

13 - For horizontal displacement of the wheels, they were developed with special bushings (1), for this adjustment loosen the screws (2) rotate said bushing (1), with a key to operate the wheels and alignment thereof with the groove, placing more or less soil laterally to the seed. **(FIGURES 46)**

14 - This adjustment should be made in accordance with the type of soil and crop.

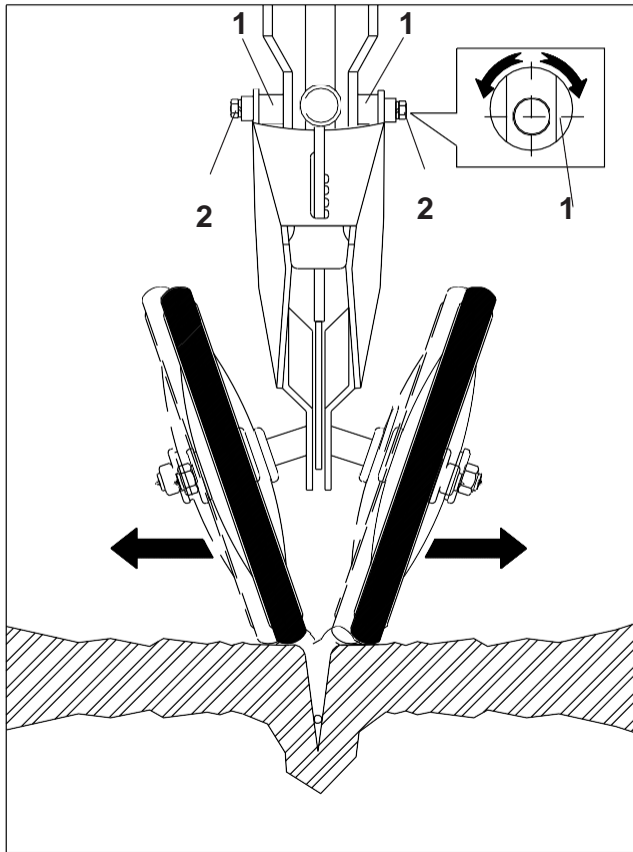

FIGURES 46

DEPTH OF FERTILISER AND PRESSURE ON SEED LINES. **(FIGURE 47)**

15 - The depth adjustment of the fertiliser is made by spring pressure exerted on the planting lines.

This adjustment is made through the bushes, as follows:

16 - To increase the depth, loosen the screw (1) and place the bushing (2) up:

17 - To reduce the depth, place the bushing (2) below

18 - To add more pressure on the spring, loosen the screw (3) and place the bushing (4) upwards.

19 - Leave a gap between the upper bushing (2) and Support of the rod (5), for oscillation of the line.

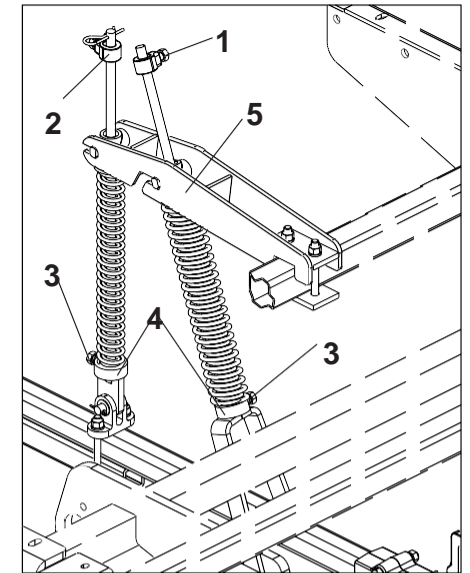

FIGURE 47



IMPORTANT

All lines must have the same setting.

ADJUSTING THE SPRING PRESSURE FOR CONVENTIONAL PLANTING. **(FIGURE 48)**

20 - For conventional planting remove the spring pressure and put limiter rings (1) in the piston rod (2).

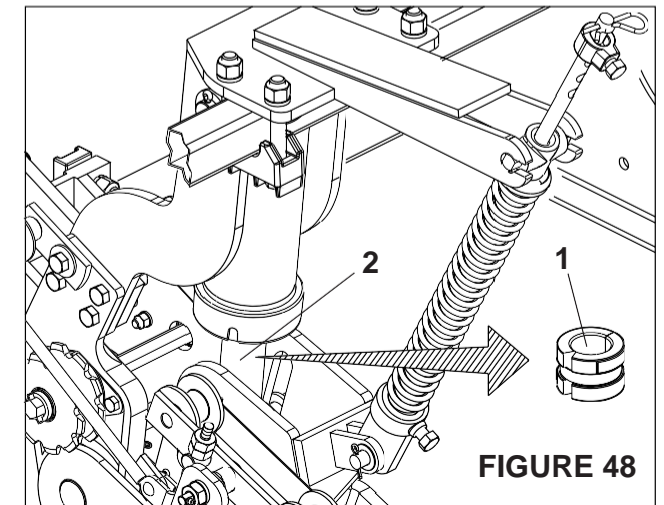

FIGURE 48

14 - FIXATION SYSTEM AND WHEEL ARTICULATION (FIGURE 49)

1 - The tire articulation system makes them become free from the pressure of the springs on the ground, thereby allowing them to oscillate and follow the irregularities of the terrain, making so that the distribution of the fertiliser and seed is not disrupted.

2 - For direct planting, the wheels operate freely and if necessary put 3/4" of water in the tires.

3 - For greater adherence to the ground, the wheel sets are provided with compression springs (1). Do not operate the seeder without them.

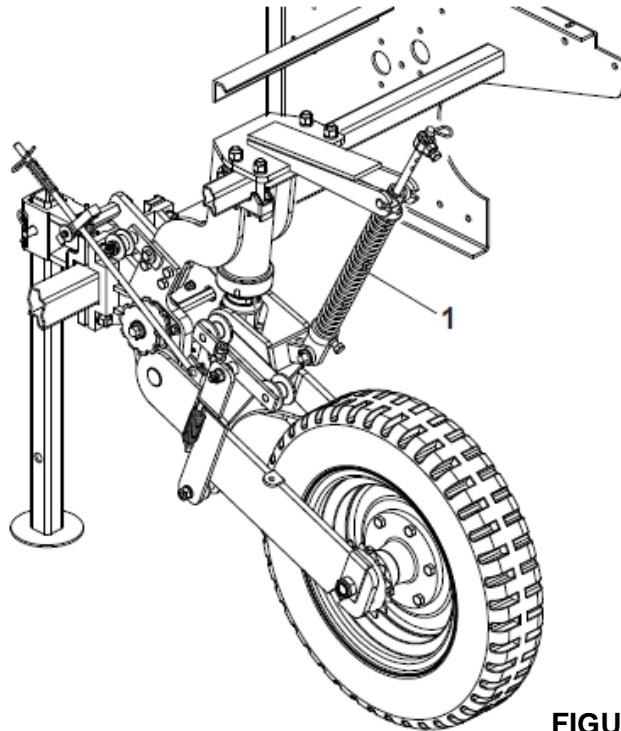

FIGURE 49

OPERATIONS

1 - After the first day of work with the seeder, retighten all screws and nuts. Check the condition of the pins, cotter pins and locks.

2 - Always keep the tires with the same calibration at **(70 lbs / in²)**, to prevent wear and maintain the uniformity of planting.

3 - Observe the lubrication intervals.

4 - When filling the tanks, check for objects in them, such as nuts, bolts, etc. Always use seeds and fertiliser free from impurities.

5 - Always observe the operation of the seeds and fertiliser distribution mechanisms and also the adjustments established at the beginning of planting.

6 - Always keep the seeder levelled, the tractor drawbar must remain fixed and the working speed should remain constant.

7 - Always check the depth of seeds, fertiliser and the pressure of the compactor wheels.

8 - Note the position of the fertiliser in relation to the seed in the soil.

9 - The line markers must be set according to the spacing of the crop to be planted.

15 – MAINTENANCE

TYRE PRESSURE (FIGURE 50)

- 1 - Tires should always be properly calibrated to avoid premature wear due to excess or lack of pressure, also ensuring accuracy in distribution.
- 2 - Calibration of the seeder tyres should be at **70 lb / square inch** for each one.

LUBRICATION

- 3 - Lubrication is essential for good performance and durability of the moving parts of the seeder, helping to reduce maintenance costs.
- 4 - Before starting the operation, carefully lubricate all grease fittings, always observing the lubrication intervals on the following pages. Make sure about the lubricant quality, avoid using products contaminated by water, earth and other agents.

TABLE OF GREASE AND EQUIVALENTS

MANUFACTURER	TYPE OF GREASE RECOMMENDED
PETROBRÁS	LUBRAX GMA 2
ATLANTIC	LITHOLINE MP 2
IPIRANGA	SUPER GRAXA IPIRANGA
	IPIRANGA SUPER GRAXA 2
	IPIFLEX 2
CASTROL	LM 2
MOBIL	MOBILGREASE MP 77
BARDAHL	MAXLUB APG 2 EP
TEXACO	MARFAK 2
	AGROTEX 2
SHELL	RETINAXA
	ALVANIA EP2
ESSO	MULTIPURPOSE GREASE H
	LITHOLINE MP 2

TABLE 10

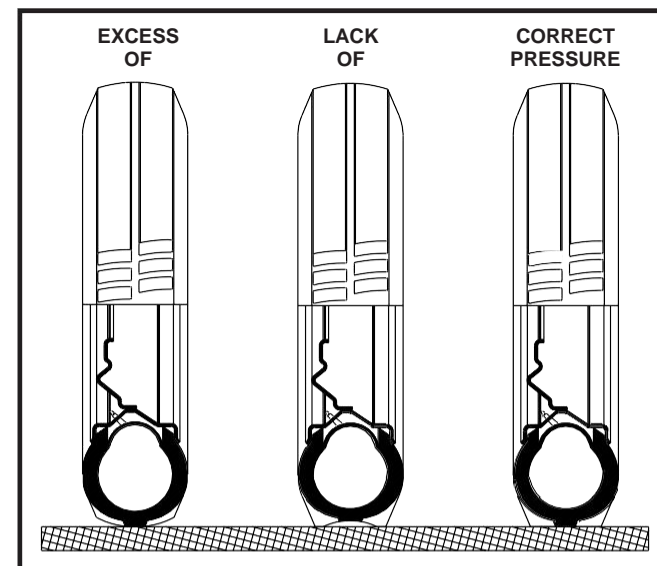

FIGURE 50

CENTRALISED LUBRICATION SYSTEM (FIGURE 51)

- 5 - The centralised lubrication system makes it faster and easier to maintain, allowing lubrication of all lateral and central points of the machine.
- 6 - Before starting the lubrication, clean all grease fittings with a lint-free cloth and replace the damaged ones.
- 7 - Lubricate all grease fittings of the centralised system every 10 hours of service.



FIGURE 51

8 - LUBRICATE EVERY 10 HOURS OF WORK (FIGURES 52)

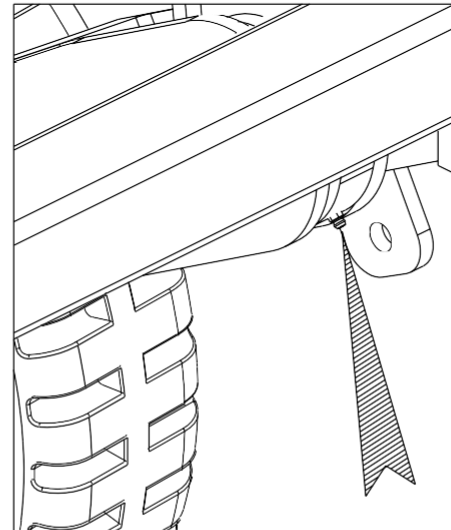
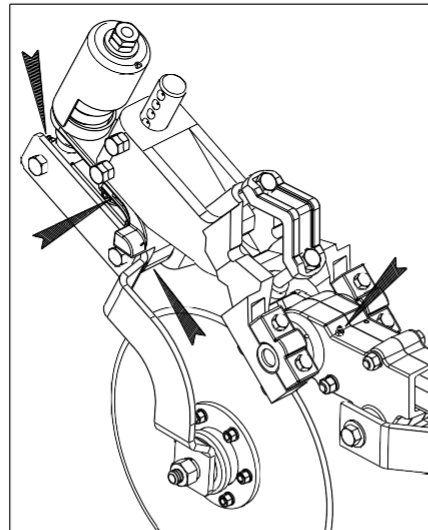
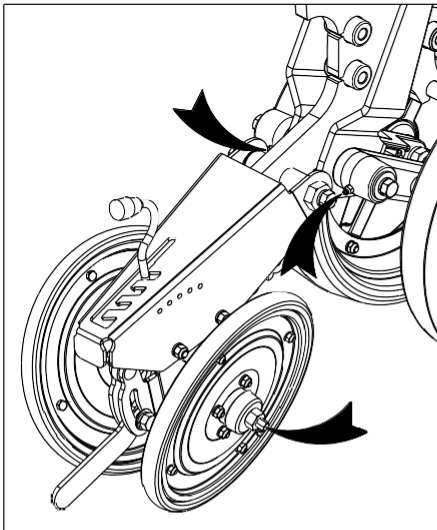
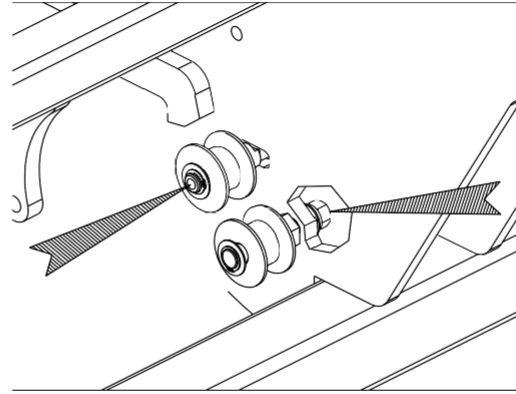
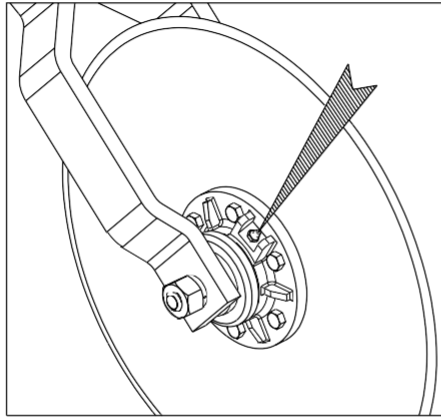
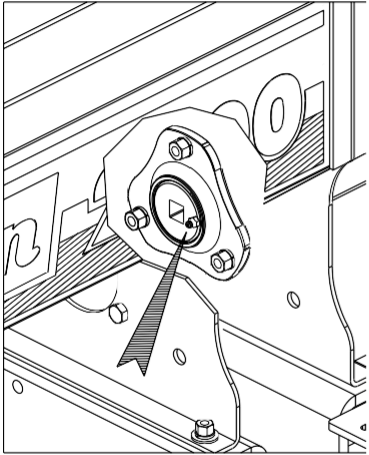

FIGURES 52

9 - LUBRICATE EVERY 30 HOURS OF WORK (FIGURES 53)

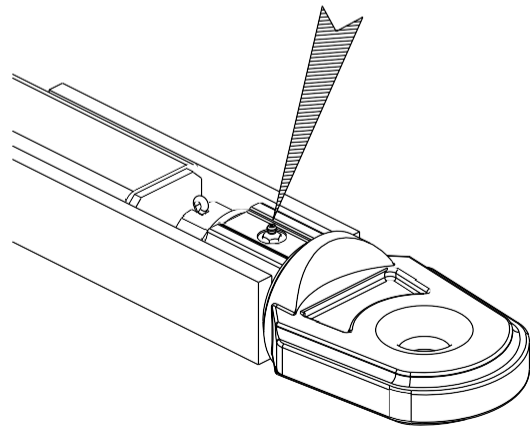

FIGURES 53

10 - LUBRICATE EVERY 60 HOURS OF WORK (FIGURES 54)

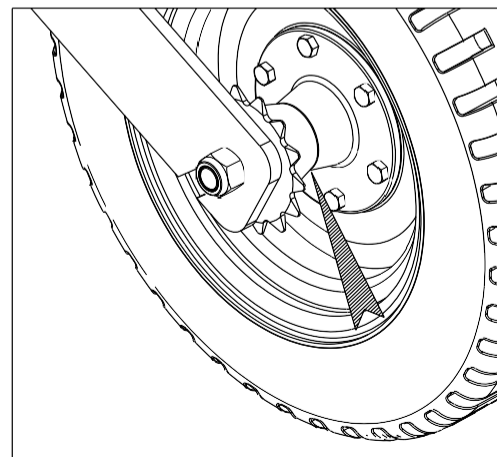
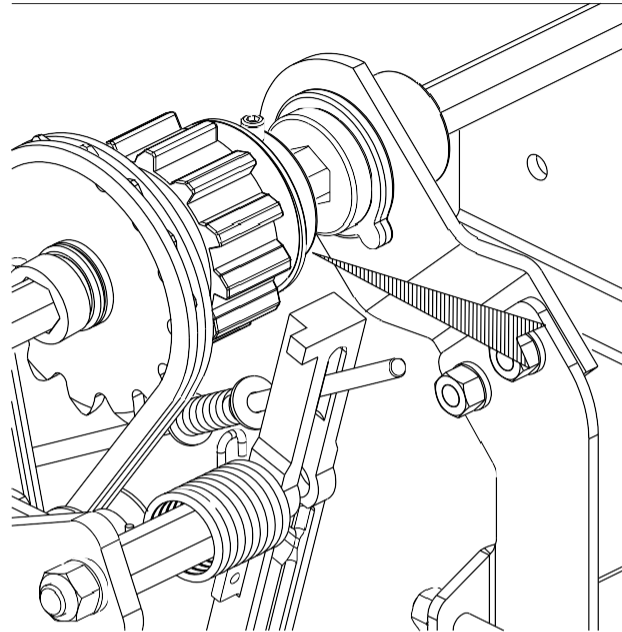

FIGURES 54



IMPORTANT

Do not put excess grease on the latch, respect the lubrication interval of every 60 hours.

11 - LUBRICATE AT EVERY 200 HOURS OF WORK (FIGURE 55)

Periodically lubricate the hubs of the double discs and depth wheels about every 200 hours, and at the end of each harvest as follows:

- Remove the retaining ring (1) of the hub (2).
- Examine the bearings and if there are gaps, adjust using the castle nut (3).
- Place new grease on the cap (4).
- Replace the cap on the hub and secure it with the retaining ring (1).

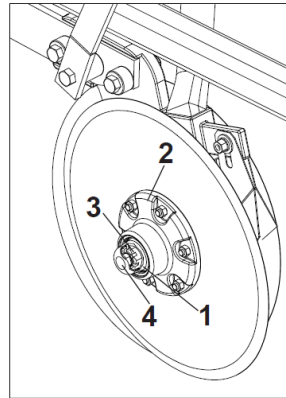

12 - OSCILLATING TENSIONER (FIGURE 56)

16 - The tensioner (5) is equipped with a torsion spring for greater flexibility, if more pressure is necessary on the tensioner, turn the knob (6) passing the spring latch (7) to the other tooth of the knob



FIGURA 56

13 - OIL CHANGE Speed Box (FIGURE 57)

- 1 - Perform an oil exchange of the Speed Box gearbox (1) after the first 30 hours, and thereafter every 1500 hours.
- 2 - The capacity of the reservoir is of 1.8 litres. It is recommended to use mineral oil ISO VG 150 at 40°C.
- 3 - To carry out the oil draining, one must remove the cap (2) located at the bottom of the Speed Box for drainage.
- 4 - To replace the oil, remove the air (3), replace the plug (2) insert the oil and check through the visor (4) if it reached the desired level.

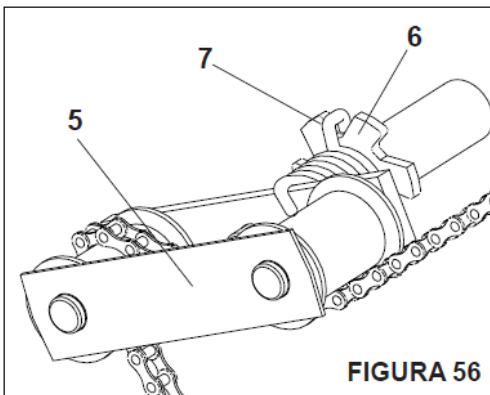

IMPORTANT

Use only the oil recommended by the manufacturer.



FIGURE 57

NOTE: When making the oil change, observe the initial positions of the vent and exhaust plugs, so they can be reassembled correctly. Make sure it is well sealed and has no leakage.

17 - OPERATIONAL MAINTENANCE

TABLE 11

PROBLEMS	PROBABLE CAUSES	SOLUTIONS
During planting fertiliser starts leaking from the safety exits.	Clogged hoses or pieces of plastic in the spiral fertiliser conductors.	Unclog the hose or remove the upper channel that gives access to the spiral, rotate the shaft in the opposite direction until the foreign body that is stuck loosens.
Fertiliser hub axle does not rotate.	Spiral blocked by wet fertiliser or excess fertiliser in the closed line.	Unclog the spirals, check if you have a loose gutter and the fertiliser may be entering by their sides.
Can not make the coupling of the quick couplings of the hoses on the tractor.	The hoses were disengaged with pressure or it is holding the weight of the seeder on the hydraulics.	Drain the hoses or place the seeder on the support feet and finally release the pressure.
A planting line is less deep than the other.	Different pressure adjustments on the depth limiting wheels or the line springs.	Set all depth wheels equally and the pressure of the line springs.
The groove is too open during planting.	Sticky soil that sticks to the discs or excessive speed of work.	Decrease the work speed.
Pistons stop running, they raise the seeder and then do not lower or vice - versa.	Different quick coupler, sphere male type and female needle type or vice - versa.	Proceed by changing the quick coupler, placing two of the same type.
Strange noise when operating or moving with a loaded seeder.	Loose wheels or wheel hub.	Retighten the wheel nuts. Adjust the wheel hub bearings.
The seeder leaves the planting line, sometimes to one side, sometimes to the other in width.	Loose tractor drawbar.	Utilize the pin accompanying the seeder. Secure the tractor drawbar in the centre hole.
It presents faults in the distribution or irregular planting.	Low suction.	Set the vacuum gauge; Check the rotation of the TDP ; Check the air tubing.
	Scraper or maladjusted vacuum switch.	Adjust the scraper; Make sure the vacuum switch is not worn.
	The diameter of the holes of the discs are small.	Adjust the hole diameter according to the seed.
	Excessive work speed	Always operate at the optimal speed for the type of crop.
Distribution in duplicate.	Maladjusted Scraper or vacuum switch	Adjust the scraper; Make sure the vacuum switch is not worn.
	Seed level is high.	Adjust the internal dispenser plate to dose the seed input stream.
	The diameter of the holes of the discs are large.	Adjust the hole diameter according to the seed.
	Excessive work speed.	Always operate at the optimal speed for the type of crop.
	Unoccupied disc row. Existence of lint, pieces of strings, clogging by excessive lubricants.	Stop the tractor, turn off the TDP and clean or repair the feeder by removing the front cover.

18 - CLEANING

FERTILISER SYSTEM METALLIC TANK (FIGURE 58)

- 1 - After planting do not leave fertiliser in the tanks. Carry out cleaning of them as follows:
- 2 - Loosen the nuts and washers (1) only on the outside of the seeder, pull the hub with the complete shaft (2), turning it to facilitate the removal **detail "A"**. Check the pvc channels (3), if they present wear, replace them. **(FIGURE 58)**
- 3 - Clean the tanks and also the shafts and then rinse them under running water.
- 4 - Reassemble the shafts with the correct assembly of the channel assembly, as the fertiliser outlet holes of both the channel and the spout must match according to **(FIGURE 58)**
- 5 - If you will store the seeder, carry out general cleaning and wash it.
- 6 - Make sure the paint is not worn, if this happened, paint a full coat, use protective oil and fully lubricate the seeder.
- 7 - Also remove the hoses conducting fertiliser, wash with water and mild soap and then replace them.
- 8 - Remove the transmission chains and keep them soaked in oil until the next planting.
- 9 - Lubricate the machine completely.

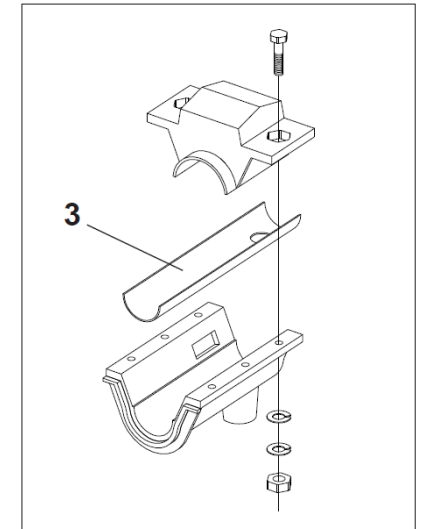
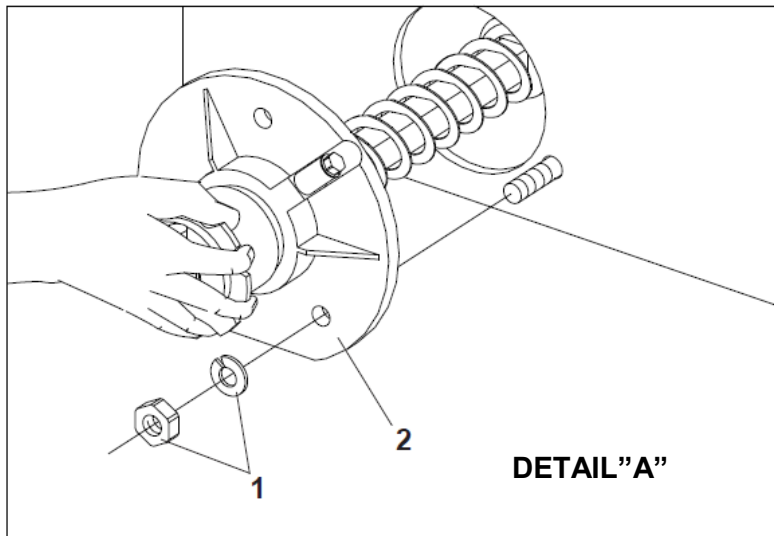

IMPORTANT

Do not use chemical detergents to wash the seeder, this may damage the paint.

FIGURE 58

FERTILISER SYSTEM POLYETHYLENE TANK (FIGURE 59)

After planting do not leave fertiliser in the tank, carry out cleaning as follows:

10 - Release the cotter (1) of the shaft (2) and screws (3) of the distributor cylinder (4). Then pull the shaft (5) backwards, according to **detail "A"** (FIGURE 59). Reassemble the shafts with the correct assembly of the fertiliser distribution system **detail "A"**.

FIGURE 59

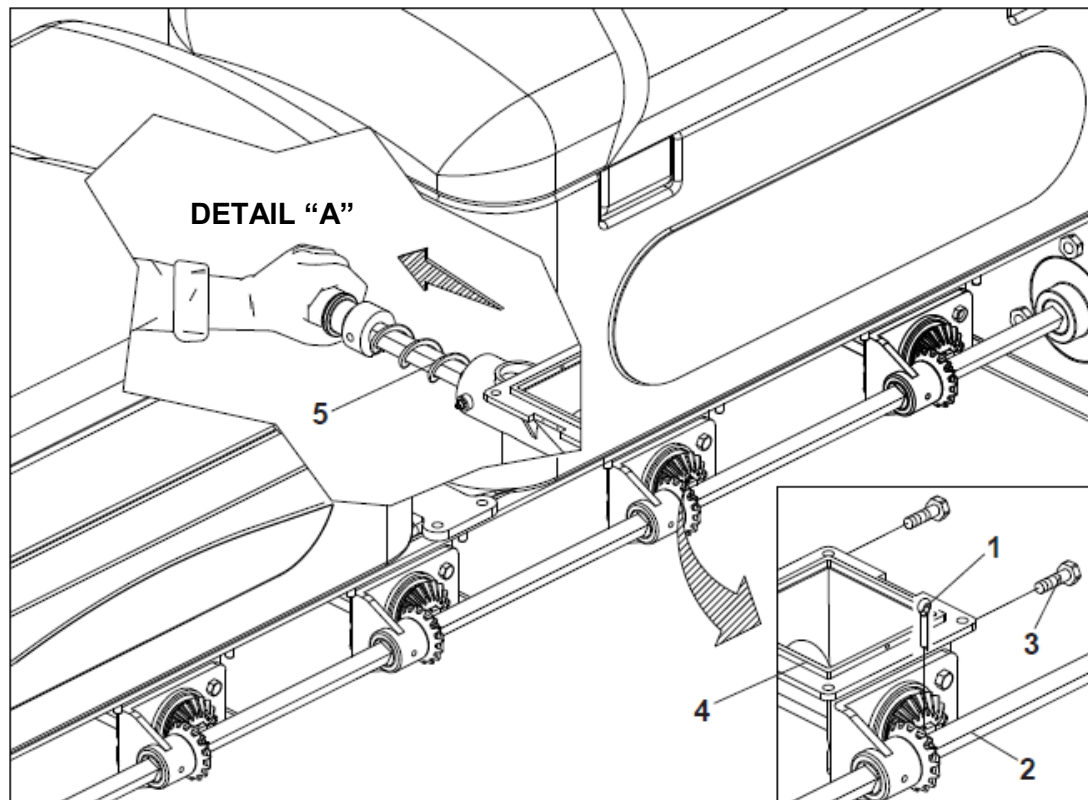

! ATTENTION

Do not insert fingers or objects into holes inside the tank, because the helical fertiliser conductor can cause serious injuries.

👍 NOTE

Always fill the fertiliser tank at the work location. Avoid any kind of impurity in the fertiliser tank. Carry out a measurement of dosage daily.

👉 IMPORTANT

Do not use chemicals to wash the seeder, as that can damage the paintwork.

19 - TURBINE

MECHANICAL TURBINE DRIVE BELT (FIGURES 60/61/62)

01 Check the belt tension daily (1) using the display "A" of the front plate (2). (FIGURE 60)

02 - The normal clearance is ± 1 cm from the centre thereof. To tension it, loosen the nut (3) and tighten the lock nut (4) of the tensioner. (FIGURE 61)



IMPORTANT

After the first hour of work with the seeder, check the belt tension.

* Cardan rotation = 540 rpm

* Turbine rotation = 5800 rpm.

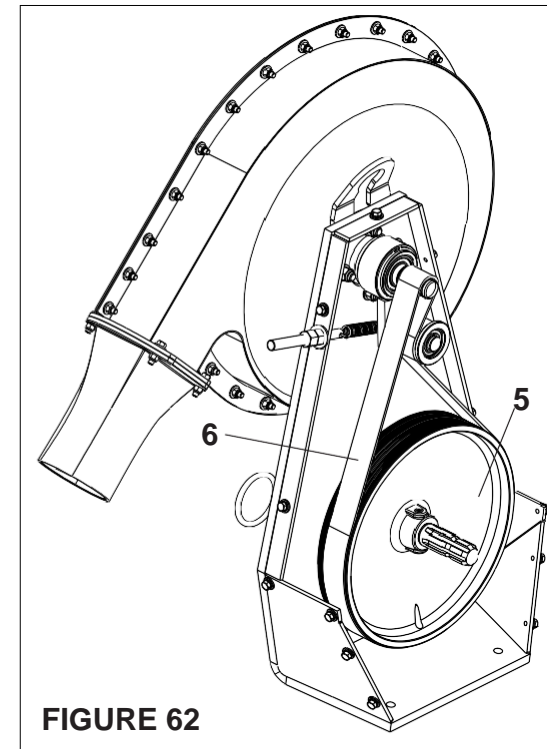

FIGURE 62

COMPENSATION OF ROTATION (FIGURE 62)

The turbines leave the factory assembled and regulated to operate at the standard rotation of 540 rpm. If you need to compensate the rotation to **1000 rpm**, proceed as follows:

14 - Replace the pulley (5) and the belt (6), which are found in the optional module parts catalogue. (FIGURE 62)

* Cardan rotation = 1000 rpm.

* Turbine rotation = 5800 rpm.

FIGURE 60

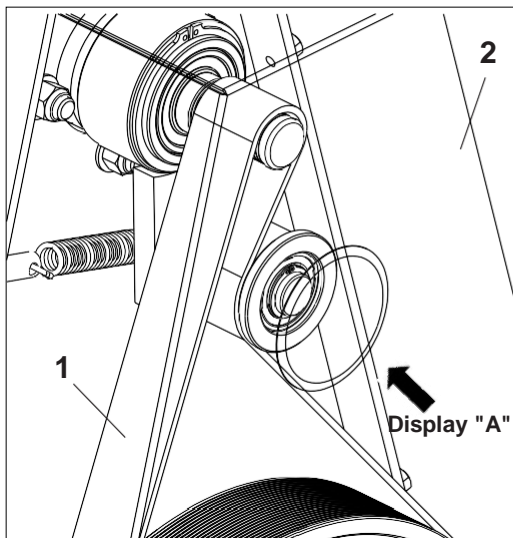
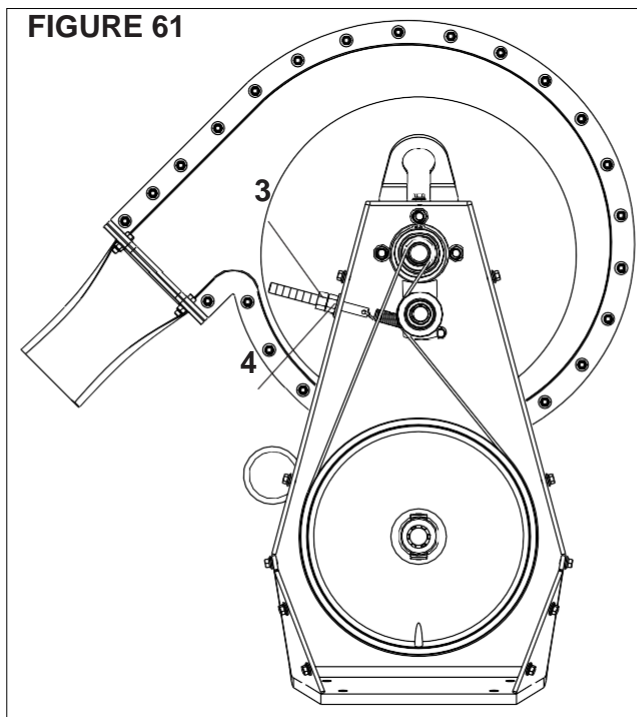
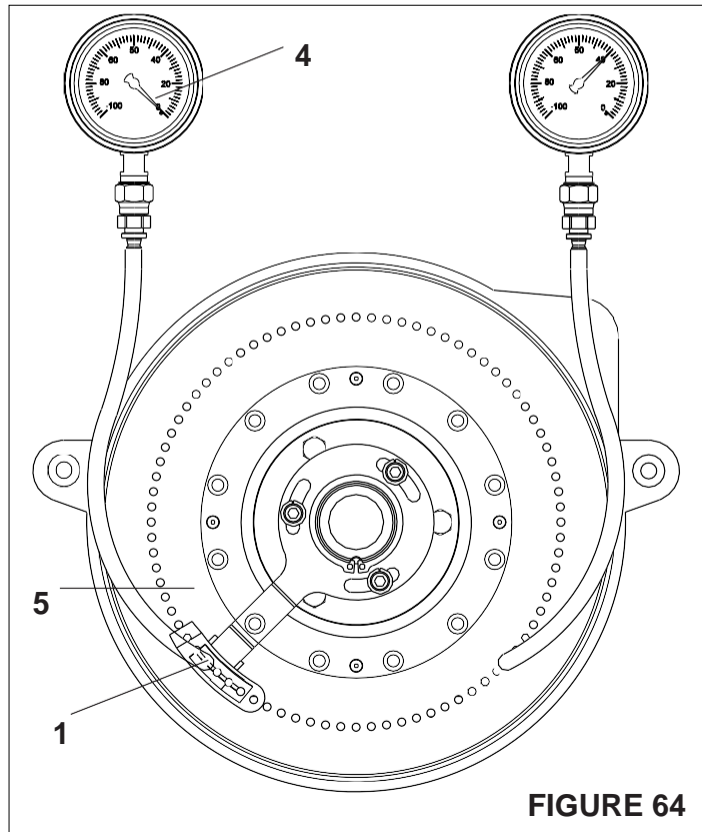

FIGURE 61



VACUUM LEVEL IN PERFORATED DISCS (FIGURES 63/64)

- 4 - Check the correct operation of the vacuum switch (1) every 20 hours, (FIGURE 63) in the following way:
- 5 - Remove the dispenser cover (2) of the distributor display (3) (FIGURE 63).
- 6 - Run the turbine at the working speed of the job.



- 07 - Take the vacuum gauge (4) and place the end of its hose into a seed hole of the perforated stainless steel disc (5). According to (FIGURE 64)

! *Note: The remaining holes should have seeds.*

- 08 - Check the vacuum level, which should be the same as the job, minimal variation may occur.
- 09 - After checking the vacuum level in the disc hole, place the end of the hose in the vacuum gauge hose (4) into the hole on the vacuum switch that must be zero, i.e., the vacuum level should drop to zero. Otherwise, the vacuum switch should be replaced (1). According to (FIGURE 64)
- 10 - To replace the vacuum switch (1), disengage the perforated seed disc of stainless steel (5), removing it from the support (6) and replacing it.
- 11 - The vacuum switch support (6) is fixed to the dispenser rotor (7). This adjustment is made at the factory and should not be modified. According to detail "A" (FIGURE 63)

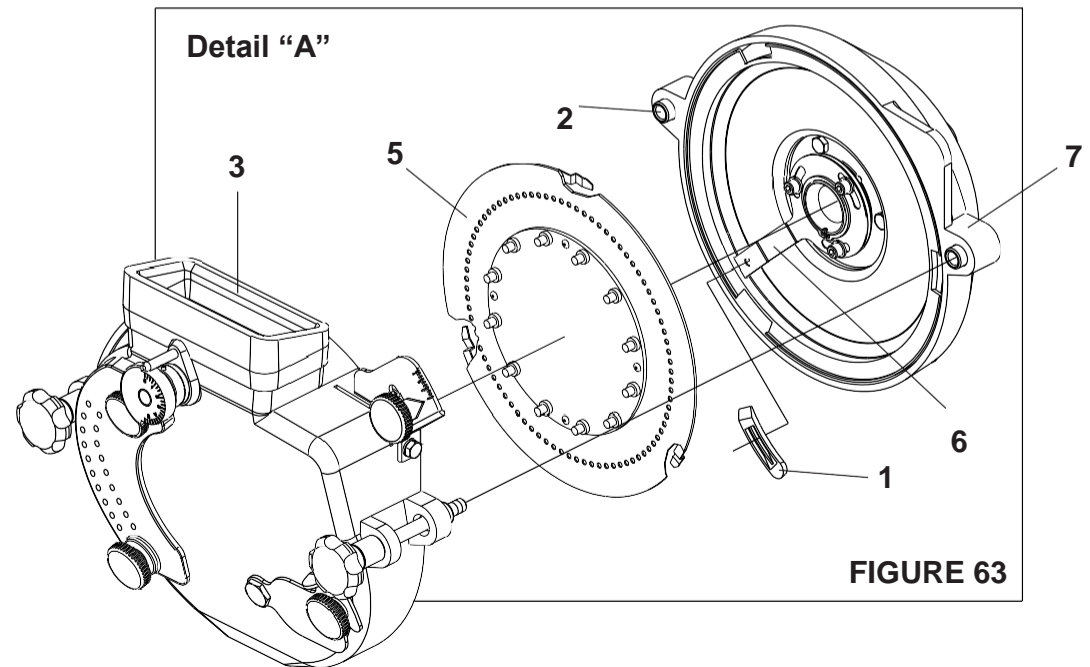

SEED SYSTEM (FIGURES 65/66/67)

- 12 At the end of each working day, we recommend emptying the seed tanks as follows:
- Place a container under the outlet (1) of the doser. **FIGURE 65**
 - Open the gate (2) of the distributor and pull the plate (3) of the deposit. (**FIGURE 66**)
 - Wait for the tank to completely empty and also the seed distributor.
 - Close the hatch (2) and the plate (3) again.
- 13 - For general cleaning of the system proceed as follows:
- Repeat the operations above;
 - Then release the handle cover (4), removing it completely and the stainless steel perforated disc (5). (**FIGURE 67**)
 - Proceed with general cleaning with soap and water throughout the system;
 - **IMPORTANT: Do not wash the acrylic display with solvent, to not affect the transparency of it;**
 - Reassemble the seed distributor:
- 14 **IMPORTANT: Do not allow light fragments, such as shredded paper, or plastics strings to fall together with seeds inside the tanks, this blocks the holes of the discs and causes failures in the planting.**
- **IMPORTANT: When using products for seed treatment (Inoculants, insecticides, graphite, etc.) it is necessary to clean the system twice a day**



IMPORTANT

Use industrial graphite or talc during planting, thus avoiding friction of the seeds with the system (Disc).

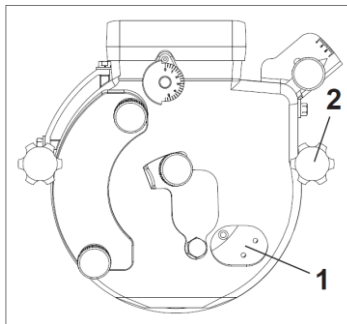

FIGURE 65

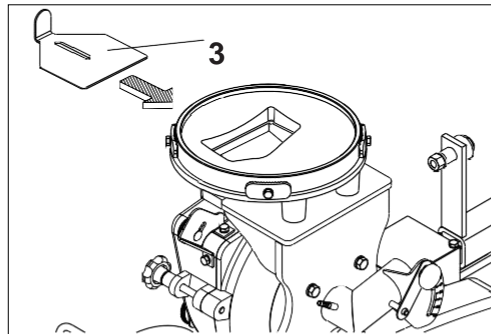

FIGURE 66

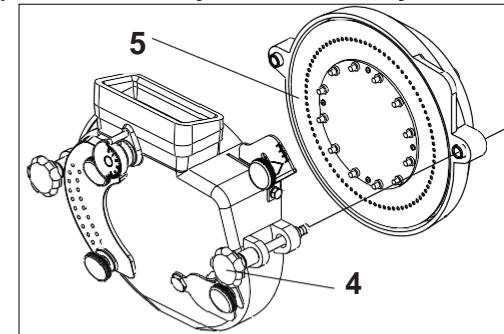

FIGURE 67

20 - OPTIONAL EQUIPMENT

DEPTH LIMITING WHEEL WITH ANGULAR ADJUSTMENT (FIGURES 68/69)

- 1 - Seed depth control is regulated individually by the convex compactor wheels (1) through the screw (2).
- 2 - The wheels are fixed on a shaft with ends at an angle (3), specially designed to enable compression, depth control and burying of the seed. To obtain these adjustments on the wheel, loosen the nut (4) and rotate the shaft (3), observing the wheel movements:
- **Parallel inclinations:** To compact the soil without accumulating earth on the seed (dry land).
 - **Tight Inclines:** To take earth away, preventing more earth from falling on the seed.
- 3 - The compactor wheels are regulated through the pin (5). For higher pressure, pull the pin out and lock it with the counter-pin (6).

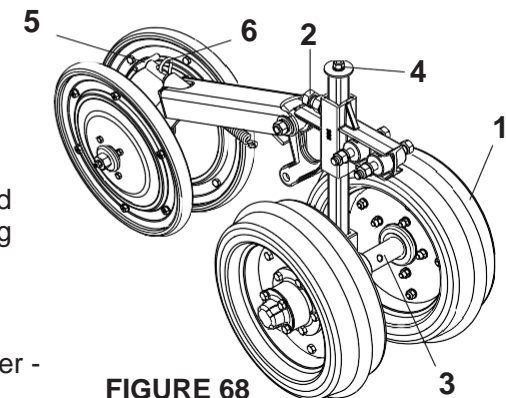
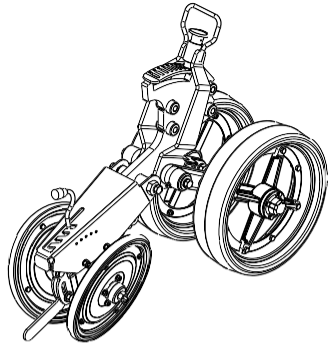
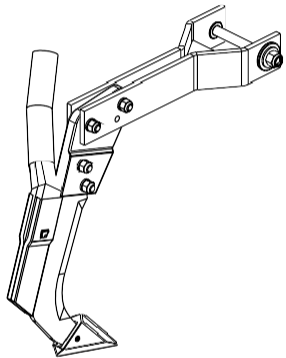

FIGURE 68

4 - CART W / ROD IN "V" AND WHEEL OF OSCILLATING DEPTH



6 - FULL TRENCHERS



8 - CART OF THE CUTTING DISC

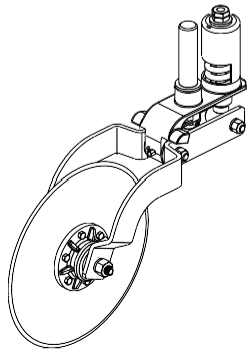

5 - CART W / WHEEL OF FIXED DEPTH AND WHEEL IN "V"

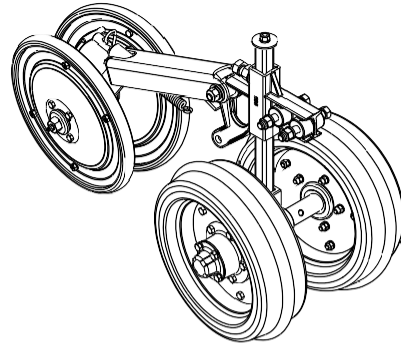

7 - DUAL FERTILISER DISC SUPPORT

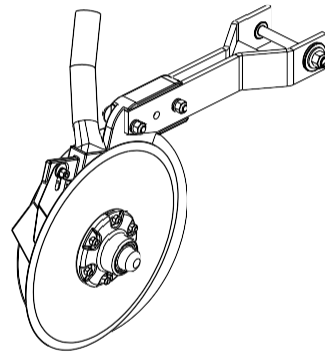

9 - FERTILISER TRENCHERS WITH DEFLECTOR

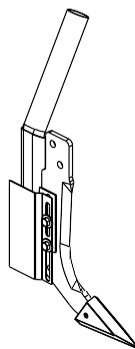

FIGURES 69

21 - PLANTING LINES (FIGURES 70)

10 - The planting line was developed in parallel or staggered systems and can be mounted with various options, such as:

- Compression wheel (1) with angular, pressure and alignment adjustments;
- Oscillating depth limiting wheel (2), with one point of support;
- Offset double disc for seeds (3) with individual cleaners;
- Offset double disc for fertiliser (4) with individual cleaners and internal scraper;
- Cutting disc 16" (5) with independent spring and regulation of individual depth;
- Sharp trencher, offset with a removable nozzle (6).

PLANTING LINE WITH DOUBLE DISC FOR FERTILISER AND CUTTING DISC

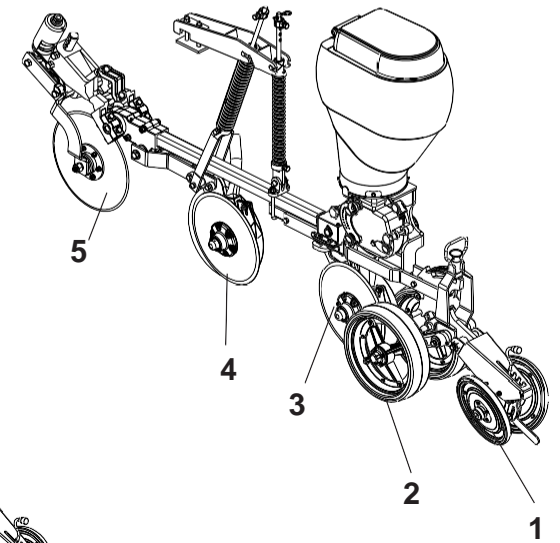

PLANTING LINE WITH TRENCHERS FOR FERTILISER AND CUTTING DISC

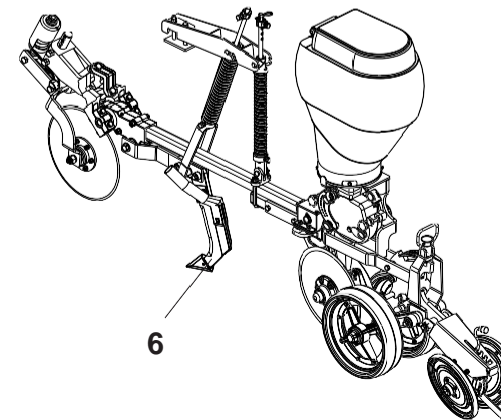

FIGURES 70

22 - IDENTIFICATION

1 - To consult the parts catalogue or request technical assistance from BALDAN, always indicate the model (1), serial number (2) and date of manufacture (3), which is on the identification label (4) of the seeder. **(FIGURE 71)**

2 - ALWAYS DEMAND ORIGINAL BALDAN PARTS.



FIGURE 71

Make identification of the data below to always have accurate information about the life of your seeder.

Owner: _____

Resale: _____

Farm: _____

City: _____ State: _____

Warranty Certificate No.: _____

Model: _____

Serial No.: _____ City: _____

Date of Purchase: ___/___/___ NF. No. _____



ATTENTION

The drawings in this manual are merely illustrative.



CONTACT

*In case of doubt, consult the After Sales Service.
Telephone: 0800-152577 / Email: tecnicoamigo@baldan.com.br*



MARKETING

*Editing of Books
and Manuals*

*Illustration and Layout: Fabricio
Código: 60550105244
Revision: 00
CPT: SLAAIR14417*



23 - CERTIFICATE

WARRANTY CERTIFICATE

BALDAN IMPLEMENTOS AGRÍCOLAS S/A ensures normal operation of the implement to the dealer for a period of six (6) months from the delivery date on the resale invoice to the first end consumer.

During this period BALDAN undertakes to remedy defects in materials and/or workmanship of their responsibility, and the labour, freight and other expenses of the responsibility of the dealer.

During the warranty period, the order and replacement of any defective parts must be made to the dealer in the region, who will send the defective part for analysis at BALDAN.

When such a procedure is not possible and exhausted the resolution capacity of the dealer, the dealer will request support from the Technical Assistance of BALDAN through the specific form distributed to resellers.

After analysing the items replaced by the Technical Assistance of Baldan, and concluded that it is not a warranty issue, so it will be of responsibility of the reseller any costs related to replacement; as well as the cost of materials, travel including accommodation and meals, accessories, lubricant and other expenses resulting from the call to the service, with the Baldan company authorised to make its billing on behalf of the reseller.

Any repairs made to the product that is within the warranty period of the dealer will only be authorised by BALDAN with prior presentation of the budget describing the work of parts and labour to be performed.

It is excluded from this term the product that is repaired or modified in shops that do not belong to the dealer network of BALDAN, as well as the use of non-genuine parts or components in the product of the customer.

This guarantee will become null when it is determined that the defect or damage is the result of improper product use, failure to follow instructions or the inexperience of the operator.

It is agreed that this warranty does not cover tires, polyethylene tanks, drive shafts, hydraulic components, etc., which is equipment guaranteed by their manufacturers.

Manufacturing and or material defects, object of this warranty term, will not constitute, under any circumstances, reason for termination of the purchase and sale contract or compensation of any nature.

BALDAN reserves the right to modify and or improve the technical characteristics of its products without notice and without obligation so to proceed with the products previously manufactured.

INSPECTION AND DELIVERY CERTIFICATE

- **SERVICE BEFORE DELIVERY:** This implement was carefully prepared by the sales organisation, checked in all its parts according to the manufacturer's instructions.
- **DELIVERY SERVICE:** The user is informed about the terms of existing warranty and instructed on the use and maintenance care.
- I confirm that I was informed about the current guarantee terms and instructed about the use and proper maintenance of the implement.

Implement: _____

Serial No: _____

Date: _____ Invoice No.: _____

Resale: _____ City: _____

State: _____ POST CODE: _____

Owner: _____ Phone: _____

Address: _____ Number: _____

City: _____ State: _____

Email: _____

Sale date: _____

Signature / Stamp of Reseller _____

1st - Owner

INSPECTION AND DELIVERY CERTIFICATE

- **SERVICE BEFORE DELIVERY:** This implement was carefully prepared by the sales organisation, checked in all its parts according to the manufacturer's instructions.
- **DELIVERY SERVICE:** The user is informed about the terms of existing warranty and instructed on the use and maintenance care.
- I confirm that I was informed about the current guarantee terms and instructed about the use and proper maintenance of the implement.

Implement: _____

Serial No.: _____

Date: _____ Invoice No.: _____

Reseller: _____ City: _____

State: _____ POST CODE: _____

Owner: _____ Phone: _____

Address: _____ Number: _____

City: _____ State: _____

Email: _____

Date of Sale: _____

Signature/ Stamp of Reseller _____

2nd Owner

INSPECTION AND DELIVERY CERTIFICATE

- **SERVICE BEFORE DELIVERY:** This implement was carefully prepared by the sales organisation, checked in all its parts according to the manufacturer's instructions.
- **DELIVERY SERVICE:** The user is informed about the terms of existing warranty and instructed on the use and maintenance care.
- I confirm that I was informed about the current guarantee terms and instructed about the use and proper maintenance of the implement.

Implement: _____

Serial No.: _____

Date: _____ Invoice No.: _____

Reseller: _____ City: _____

State: _____ POST CODE: _____

Owner: _____ Phone: _____

Address: _____ Number: _____

City: _____ State: _____

Email: _____

Date of Sale: _____

Signature/Stamp of Reseller _____

3rd Manufacturer

Please send this copy filled within 15 days to BALDAN.





1.74.05.0059-5

AC MATÃO
ECT/DR/SP

ANSWER-CARD

STAMP NOT REQUIRED

POSTAGE WILL BE PAID BY:



Baldan



BALDAN IMPLEMENTOS AGRÍCOLAS S/A.

Av. Baldan, 1500 | Nova Matão | CEP: 15993-000 | Matão-SP |
Brasil Phone: (0**16) 3221-6500 | Fax: (0**16) 3382-6500
Home Page: www.baldan.com.br | e-mail: sac@baldan.com.br
Export: Phone: 55 16 3321-6500 | Fax: 55 16 3382-4212 | 3382-2480
e-mail: export@baldan.com.br



BALDAN IMPLEMENTOS AGRÍCOLAS S/A.

Av. Baldan, 1500 | Nova Matão | CEP: 15993-000 | Matão-SP | Brasil

Fone: (16) 3221-6500 | Fax: (16) 3382-6500

Home Page: www.baldan.com.br | e-mail: sac@baldan.com.br

Exportação: Fone: 55 (16) 3221-6500 | Fax: 55 (16) 3382-4212 | 3382-2480

e-mail: export@baldan.com.br



6 0 5 5 0 1 0 5 2 4 4