

SMB MÚTIPLA

4000/5000/6000

Speed Box



Instruction Manual



www.baldan.com.br

INTRODUCTION

We appreciate your purchase and congratulate you for the excellent choice you just made because you have purchased a product manufactured with technology from **BALDAN IMPLEMENTOS AGRÍCOLAS S/A.**

This handbook will guide you through the procedures that are necessary since its acquisition up to the operating procedures of use, security and maintenance.

The **BALDAN** ensures that have delivered this farming implement to the dealer in perfect conditions.

The dealer is responsible for the custody and maintenance of this farming implement and also for the assemblage, retightening, lubrication and overhaul.

In the technical delivery, the dealer must advise the user on its maintenance, security, its obligations under any technical assistance, the strict observance of the guarantee and reading the instruction handbook.

Any request for technical assistance under warranty should be made to the dealer where it was purchased.

We reiterate the need for careful reading of the guarantee certificate and observance of all items in this handbook, as doing so, the useful life of your farming implement will increase.



PRODUCT PRESENTATION

The **Múltipla Baldan - SMB Speed Box** seeder was developed in models 4000, 5000 and 6000 with minimum spacing between lines of 165 mm. **SMB** meets both winter crops and summer crops. It is part of a multiple model in which instead of purchasing one machine for the planting of large grains (summer crop) and one machine for the planting of small grains (winter crop), the farmer purchases only this machine with two options. Its main difference is the versatility to meet all cultures.

The fertilizer tank is provided in stainless steel or carbon steel with epoxy treatment and helical spring system for fertilizer distribution (Baldan unique floating spiral system).

The Baldan sowing machines are the only equipped with gearbox with oil bath (Speed Box) with 62 quick-change adjustment options for fertilizer and seed distribution, with major advantages due to their easiness, accuracy and diversity of options for adjustment that added to their long autonomy, result in higher daily productivity.

Its unique centralized lubrication system provides a reduction in time used to lubricate the machine due to the unification of the main points in the panels.

It has side stairs for the supply of fertilizer and seed tanks, and non-slip platform with protective hand railing.

Articulated wheel system to follow the ground irregularities, keeping the grip of the tire to the ground; this system is equipped with wide, low calibration and high fluctuation tires, which reduces the compaction rate and sliding on the soil.

The fertilizer and seed tanks have been developed with great autonomy in accordance with the machine model, with grooved helical rotor system for winter crops.

Baldan seed distribution system with distributing discs, rings, and Universal distribution box.

The 20" cutting blades have independent pressure spring and individual depth adjustment for the planting of large grains.

The double disc for fertilizer and seeds are off-center with individual internal cleaners and double hub of the spreader discs assembled with two conical bearings of permanent lubrication. The furrow openers for fertilizer application are sharp with replaceable tips and shut-off security system.

The **SMB** is equipped with pantograph system, with front line marker, which can optionally be provided with tank for fine seed distribution.

INDEX

01 - Normas de segurança	4 a 6
02 - Parts.....	7
03 - Technical specifications	8
04 - Assemblage.....	9
<i>Coupling head</i>	9
<i>Assembling the compaction wheel.....</i>	10
<i>Assembling the compaction and depth wheel cart</i>	10
<i>Assemblage of the line marker.....</i>	11
<i>Assemblage of the small seed box - optional.....</i>	12
<i>Assemblage of the planting system.....</i>	13
05 - Tractor coupling.....	15
06 - Adjustments and operations.....	16 a 20
07 - Adjustments for seed distribution	21 a 24
08 - Adjustment for seed distribution - universal system.....	25
09 - Adjustment for the distribution of large seeds.....	26
10 - Adjustment for the distribution of small seeds	27 a 30
11 - Adjustment for fertilizer distribution	31
12 - Practical calculation for fertilizer and seed distribution	40
<i>Practical test for measuring the amount of fertilizer and seed distribution</i>	40
<i>Adjustment of the line marker disc.....</i>	40
13 - Depth adjustment	41
<i>Furrow opening and fertilizer position on the ground.....</i>	41
<i>Seeder system – large seeds.....</i>	41
<i>Furrower position.....</i>	41
<i>Adjustment of the cutting disc depth.....</i>	41
<i>Adjustment of the double disc cleaners</i>	41
<i>Oscillating depth limiting wheel</i>	42
<i>Epth and “v” compaction wheel</i>	42
<i>Adjusting the “v” compaction wheel</i>	42
<i>Adjustment of the pressure spring for conventional planting.....</i>	43
<i>Adjusting the “v” compaction wheel</i>	43
14 - Operations.....	44
15 - Maintenance.....	45 a 47
16 - Oil replacement (speed box).....	48 a 49
17 - Cleaning.....	50 a 51
18 - Optional equipment.....	52
19 - Planting carts.....	53
20 – Mixing set - optional.....	54
21 - Digital hectare meter - baldan	55 a 57
22 - Identification	58

01 - NORMAS DE SEGURANÇA



THIS SYMBOL INDICATES IMPORTANT SAFETY WARNING. WHENEVER YOU FIND IT IN THIS HANDBOOK, CAREFULLY READ THE MESSAGE THAT FOLLOWS AND BE AWARE OF THE POSSIBILITY OF PERSONAL INJURY.

! ATTENTION

- Do not operate the seeder if the transmission hoods are not properly fixed.
- Only remove the hoods to make the replacement of gears, put them back immediately.
- When doing any work in the machine transmission, turn the ratchets off.
- Do not make adjustments with the machine in motion.

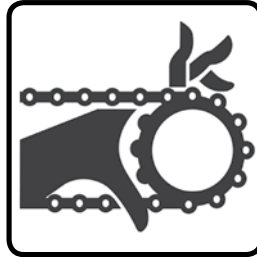
**! ATTENTION**

- The hydraulic fluid is under pressure and can cause serious injuries in case of leaks. Periodically check the conservation condition of the hoses. If there is evidence of leaks, replace them immediately.
- Before connecting or disconnecting hydraulic hoses, relieve the pressure of the system, triggering the command with the tractor off.

**! ATTENTION**

- Keep yourself away from active elements of the machine (Discs) because they are sharp and can cause accidents.
- In doing any maintenance service on the discs, always use safety gloves.

**! ATTENTION**

- When operating the seeder, do not allow the permanence of people on the machine.
- Do not stay on the platforms with the machine in motion.



ATTENTION

- Avoid accidents caused by the intermittent action of line markers.
- When operating the seeder, make sure there are no people on line markers or around their area of action.







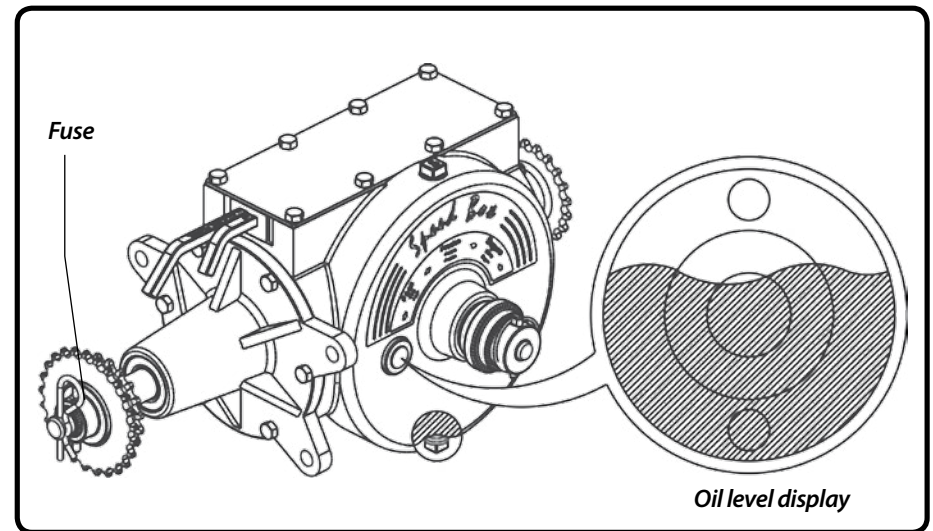









ATTENTION

- Check the oil level daily.
- Replace the oil in the gearbox (Speed Box) after the first 30 hours of work, then every 1500 hours, always using ISO VG 150 mineral oil at 40°C (amount of oil used 1.8 liters).
- Use only factory original fuse, because only this one has controlled hardness.





The mismanagement of this equipment can result in serious or fatal accidents. Before placing the equipment in operation, carefully read the instructions in this handbook. Make sure that the person responsible for the operation is instructed on the proper and safe handling, if has read and understood the handbook of this product.

- 01 -  When operating the equipment, do not allow people to stay very close or on it.
- 02 -  In making any assembling and disassembling service in the discs, always use safety gloves.
- 03 -  Before connecting or disconnecting hydraulic hoses, relieve the system pressure by moving the command with the tractor off.
- 04 -  Periodically check the conservation status of the hoses. If there is evidence of leaks, immediately replace them because the oil works under high pressure and can cause serious injury.
- 05 -  Do not wear loose clothing as they can become entangled in moving parts.
- 06 -  When turning the tractor engine on, be properly seated on the operator's seat and aware of the correct and safe management of both tractor and implement. Always put the selector lever in neutral, turn off the power take-off command and place the hydraulic commands in the neutral position.
- 07 -  Do not run the engine in indoor environments without adequate ventilation, as the exhaust fumes are harmful to health.
- 08 -  When maneuvering the tractor to the implement hitch, make sure that there is plenty of room and that there is nobody very close, always do the maneuvers in low gear and be prepared to brake in emergency situations.
- 09 -  Do not make adjustments with the implement in operation.
- 10 -  When working on slopes, proceed with caution when trying to maintain the necessary stability. In case of early imbalance, reduce the acceleration, turn the tractor wheels to the side of the terrain slope.
- 11 -  Always drive the tractor at speeds compatible with safety, especially when working on uneven ground or slopes, always keep the tractor engaged.
- 12 -  When driving the tractor on roads, keep the brake pedals connected and use of safety signs.
- 13 -  Do not operate the tractor if its front is light. If there is a tendency to rise, add weights on the front or front wheels.
- 14 -  Leaving the tractor, put the selector lever in neutral and pull the parking brake.

SEMEADORA MÚTIPLA BALDAN - SMB SPEED BOX 4000 / 5000 / 6000

(COM DEPÓSITO DE ADUBO / SEMENTE METÁLICO E INOX)

Figure 01

02 - PARTS

- 01 - Chassis
- 02 - Speed Box system - seed
- 03 - Speed Box system - fertilizer
- 04 - Foot support
- 05 - Front line marker
- 06 - Coupling head
- 07 - Head adjustment
- 08 - Wheel set
- 09 - Coupling shackle
- 10 - Marker disc
- 11 - Rear step
- 12 - Handrail
- 13 - Fertilizer and seed tank
- 14 - Tank cap
- 15 - Protective cover of chains
- 16 - Hose Support
- 17 - Hydraulic Hoses
- 18 - Anti-slip platform
- 19 - Short hoses
- 20 - Planting cart
- 21 - Ratchet lever

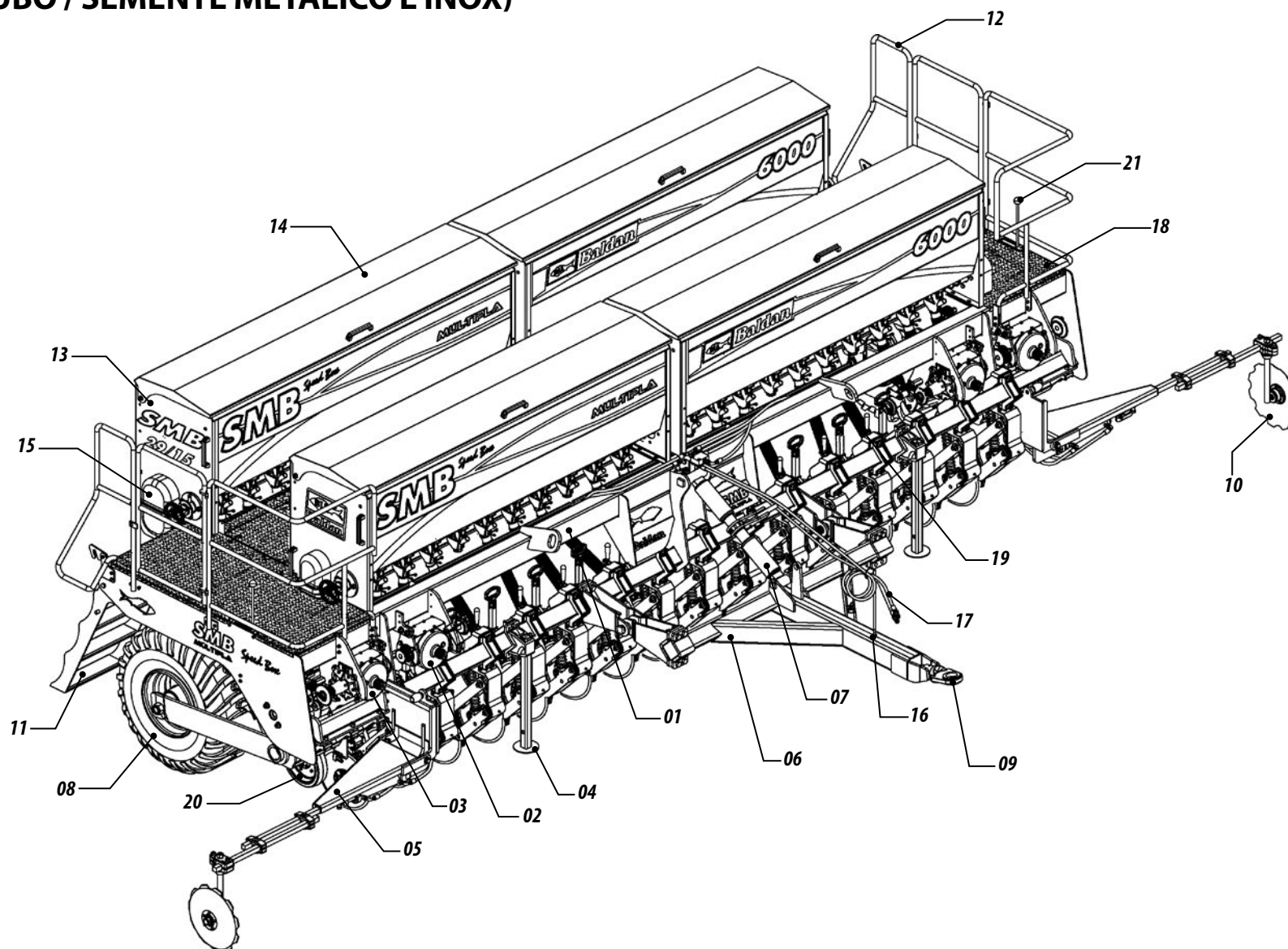

03 - TECHNICAL SPECIFICATIONS

Table 01

Modelo	Nr of rows	Useful width (mm)	Working width (mm)	Row spacing (mm)	Total width (mm)	Hopper capacity (L)			Approx. weighth (Kg)	Tyres	Total heighth (mm)	Total lenght (mm)	Required tractor power (Hp)
						Seed	Fertilizer	Small Seed					
4000	21	3300	3465	165	4980	1048	1316	30	5154	400 x 60 - 15.5 (14 Ply)	2230	4700	100 - 140
	11		3610	310					6380				
	8		3750	450					5579				
5000	25	3960	4125	165	5640	1244	1560	35	6047	400 x 60 - 15.5 (14 Ply)	2230	4700	120 - 160
	13		4270	310					7099				
	9		4410	450					6031				
6000	29	4620	4785	165	6300	1440	1804	41	6200	400 x 60 - 15.5 (14 Ply)	2230	4700	140 - 180
	15		4930	310					7818				
	11		5070	450					6750				

The BALDAN reserves the right to change technical specifications of this product without previous notice.
The technical specifications are approximate and informed under normal working conditions.

04 - ASSEMBLAGE

COUPLING HEAD

- 1- The seeders are factory semi-assembled, and only a few components must be assembled according to directions below:
- 2- Place the head (1) in the working position by removing the lock (2) and pin (3) they were placed for transportation. FIGURE 02.
- 3- Introduce the regulator (4) into the head, fixing with the pin (5) and lock (6).
- 4- Next, place the hose support (7) with the nut (8) in the head (1). FIGURE 03.

Figure 02

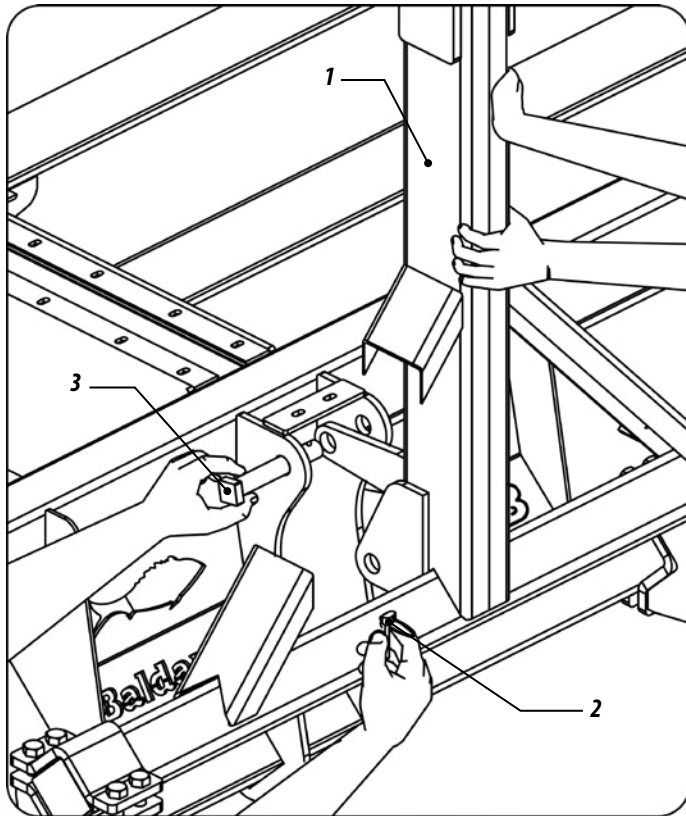
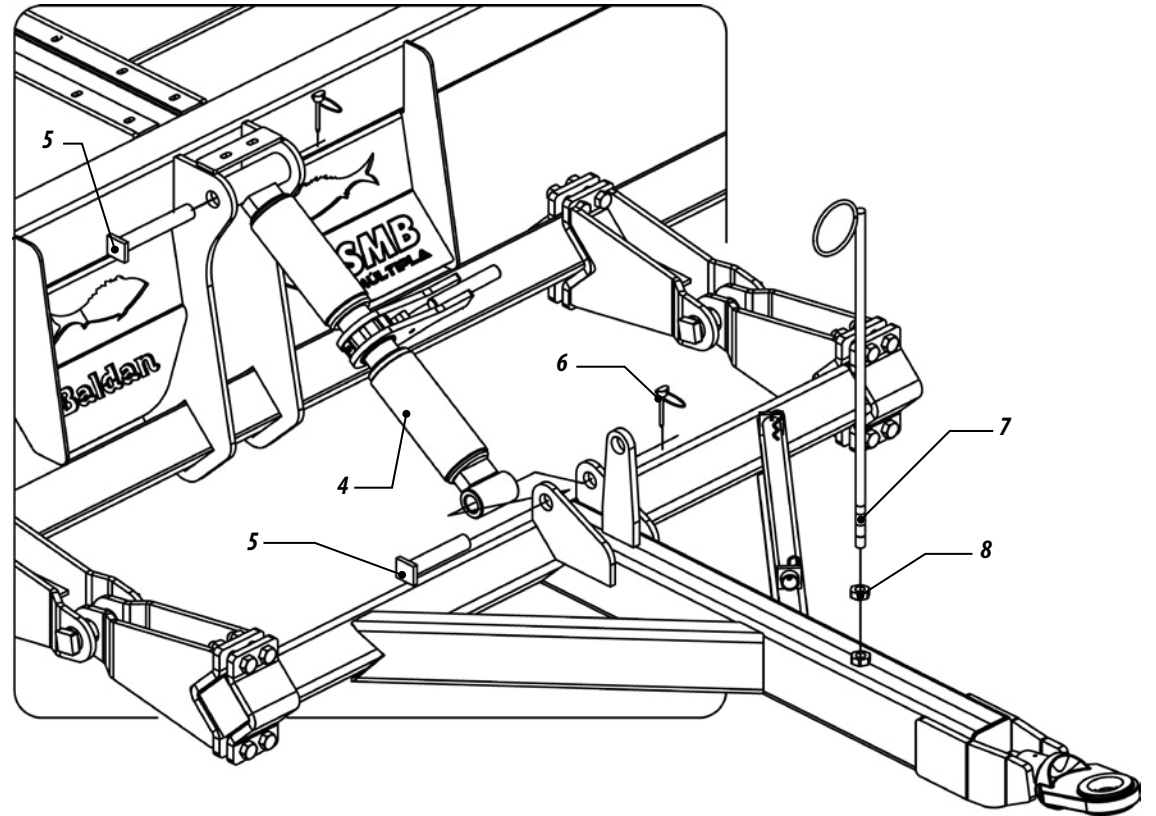

Figure 03



ASSEMBLING THE COMPACTION WHEEL

- 1- Attach the wheel support (1) in the wheel cart (2), fixing it with the sleeve (3), washer (4) and screw (5). Place the lever (6) fully forward (position "A") and hook the spring (7) in the wheel support (1). Figure 04.

Figure 04

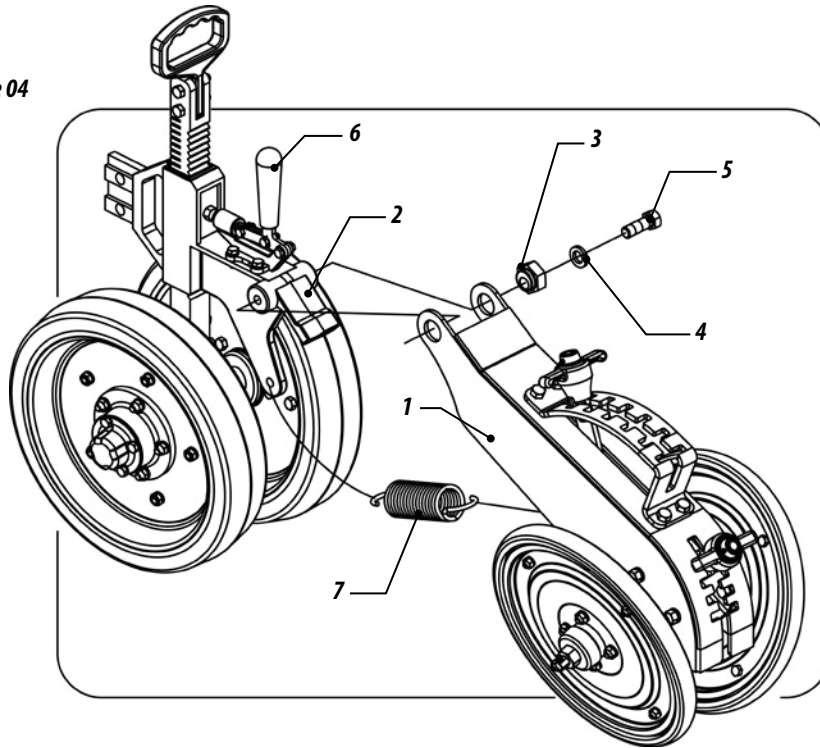

IMPORTANT

When finishing the assemblage, make a general review of the seeder, make sure that there are no objects (nuts, screws or others) inside the tanks.

Retighten all screws and nuts, review all the pins, cotters, locks and hoses.

ASSEMBLING THE COMPACTION AND DEPTH WHEEL CART

- 2- Introduce the complete wheel cart (1) between the planting line plates (2) by fixing it with screws (3), washers and nuts (4). Figure 05.

Figure 05

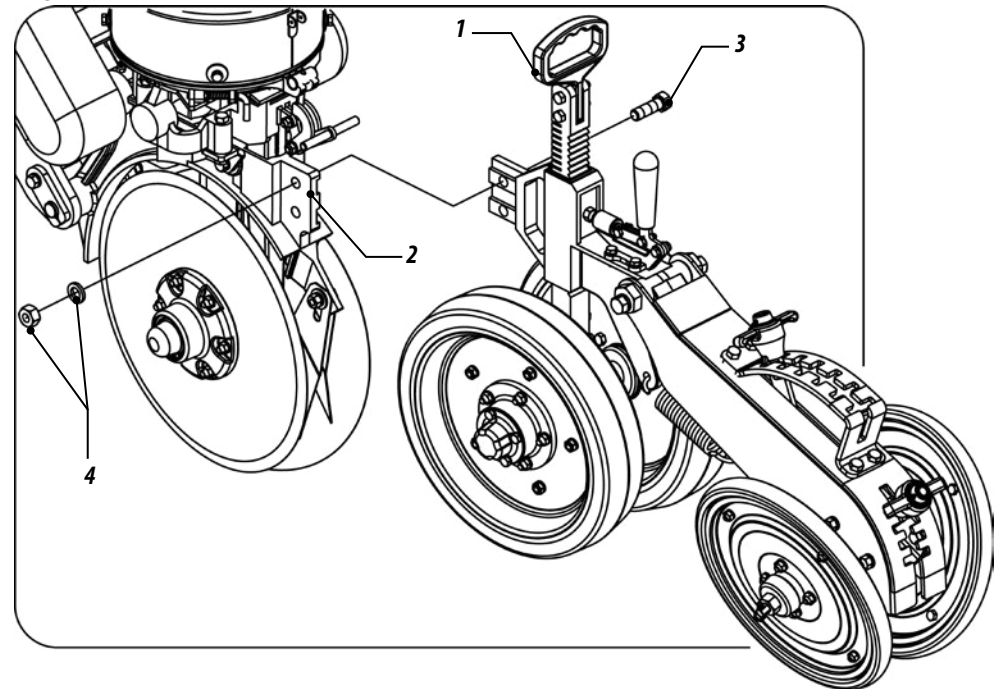

ASSEMBLAGE OF THE LINE MARKER

- 1- Assemble the line marker as follows;
- 2- Place the marker support (1) in the set (2) through the screw (3) washers and nuts (4).
- 3- Fix the frame (5) to the support (1) with screw (6) washers and nuts (7)
- 4- Then, introduce the square bar of the marker (7) in the frame (5) and fix it with screws (8) washers and nuts (9).
- 5- Assemble the maker disc (10) in the bar (7) and tighten it with nut and washer (11).

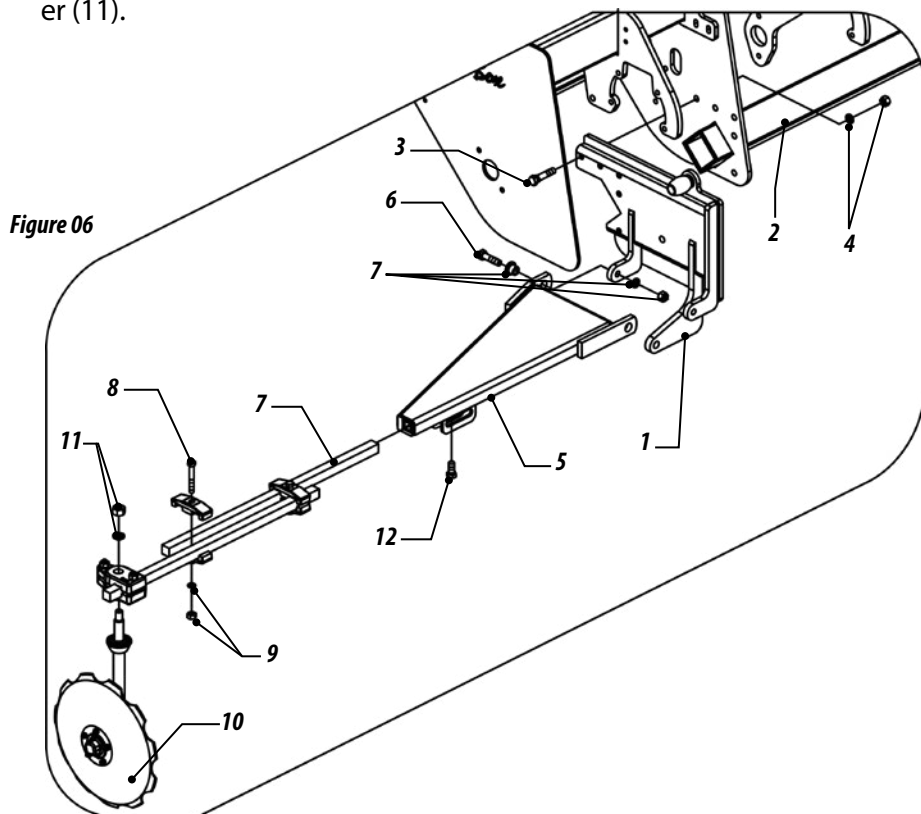

- 6- Lock the marker with screw (12). Figure 06.
- 7- Then, fix the hydraulic cylinder (13) with pins (14) washers and cotter (15).
- 8- Make the connection of hoses (16), make sure that the hoses do not become too stretched, damaging the equipment. Figure 07.

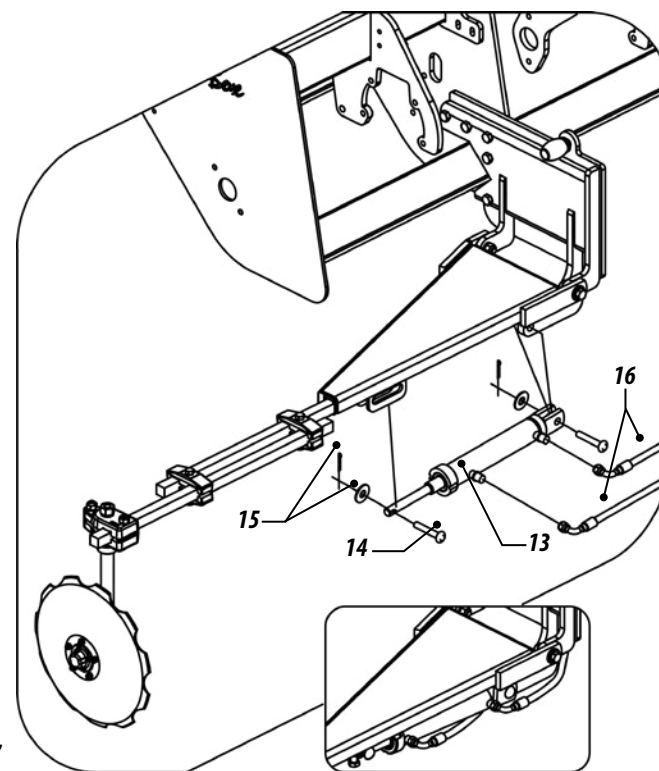

IMPORTANT

Make sure that the hoses do not become too stretched, damaging the equipment.

ASSEMBLAGE OF THE SMALL SEED BOX - OPTIONAL

- 1- Fix the small seed tank (1) in the front part of the fertilizer and seed tank (2) with screws (3) washers and nuts (4).
- 2- Introduce the gear (5) in the hub of the seed tank (6), fixing with screw (7), washers and nuts (8).
- 3- Place the chain (9) between the gears of the small seed box and seed box shaft, stretch the chain through the chain tensioner (10).
- 4- Fix the wheel (11) in the hub of the small seed box with screw (12) and nut (13). Then, place the latch (14).
- 5- Introduce the small seed hoses (15) in the spouts (16). Figures 08.

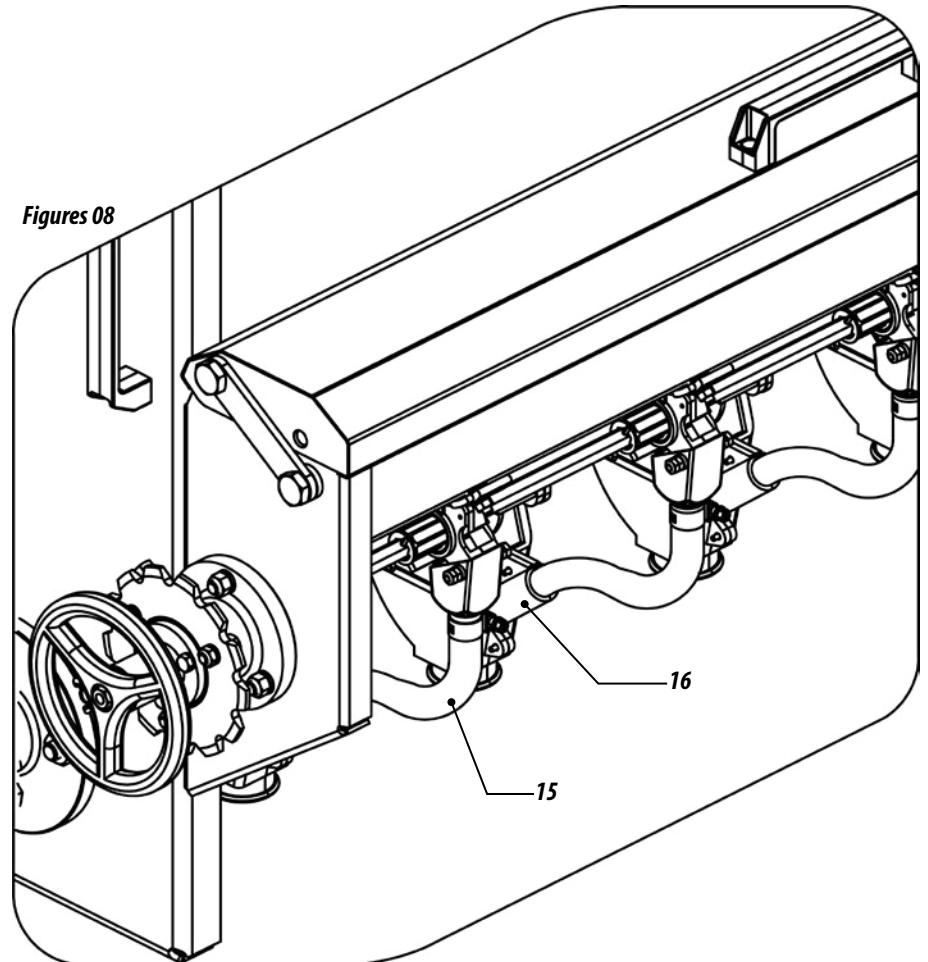
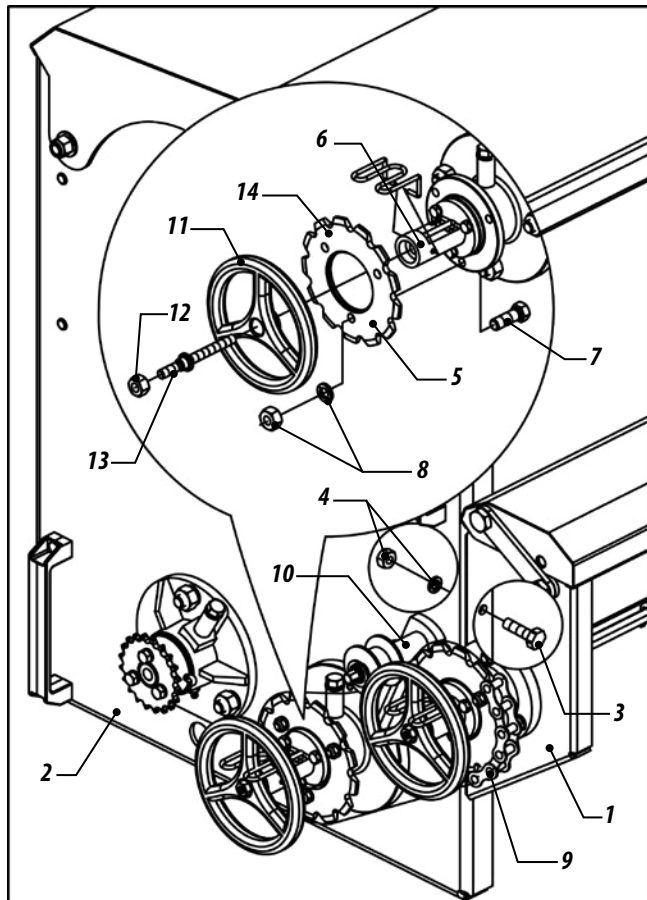

⚠ WARNING

Make sure that the hoses do not become too stretched, damaging the equipment.

ASSEMBLAGE OF THE PLANTING SYSTEM

- 1- When working with the machine in the sowing of large seeds, assemble the planting system as follows;
- 2- Fix the bearings (1) to the chassis of the seeder with screw (2), washers and nuts (3). Fix the brackets (4) and clamp (5) in the life (6) of the set with screw (7), washers and nuts (8)
- 3- Place the hexagonal shaft (9) with sleeve (10) and gears (11)
- 4- With the bearings support already assembled, touch them at the hexagonal shaft ends and lock them with the cotter pin (12). Figure 09.

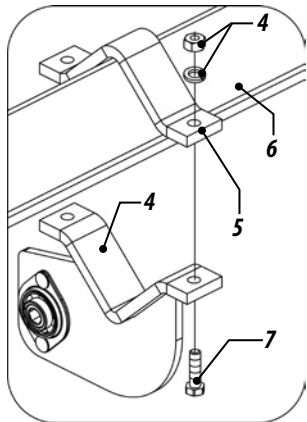
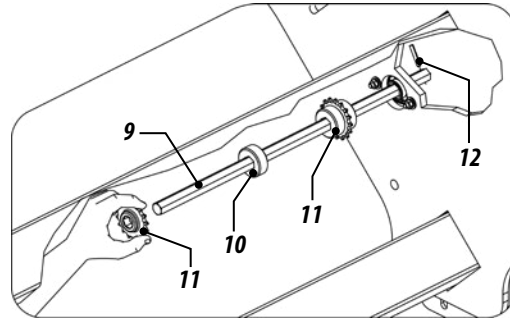
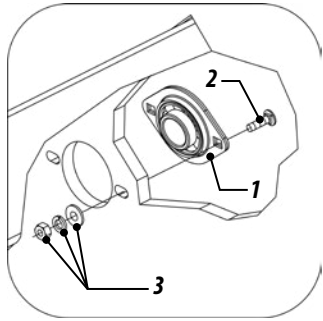

Figures 09

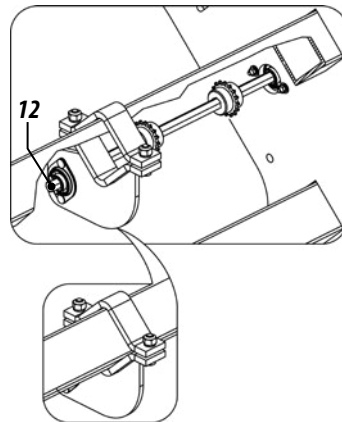

- 5- Then, assemble the other supports at the lower part of the seeder (13) with screw (14) washers and nuts (15), clearing bearings (16), sleeve (17) with screw (18), washers and nuts (19) ;
- 6- Then, fix the bracket (20), clamp (21), chain stretcher (22) with screw (23), washers and nuts (24). Figure 10.

Note: During assemblage, do not tighten the screws of the bearings and supports, leaving this to the end of operation.

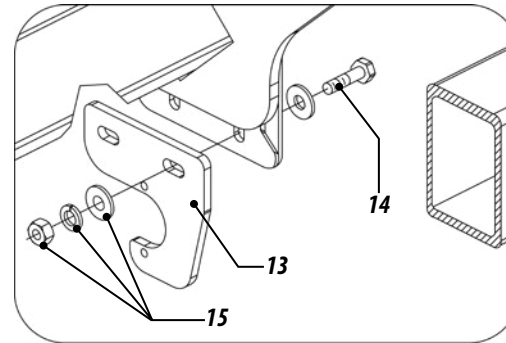

Figures 10

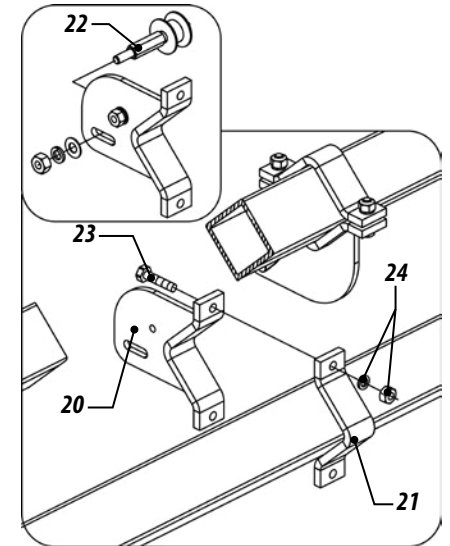
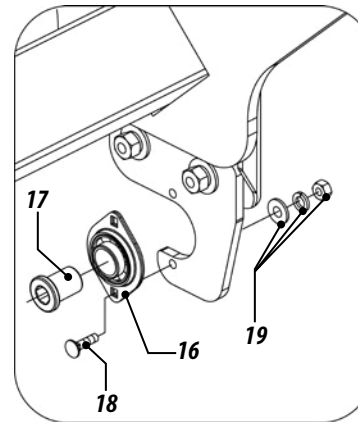

- 7- Finally, pass the hexagonal shaft (25) through the clearing bearings (26) and planting lines (27);
- 8- Then, lock the shaft with cotter pin (28), tighten all screws and check the position and tension of the chains (29) in the chain stretchers (30). Figure 11.

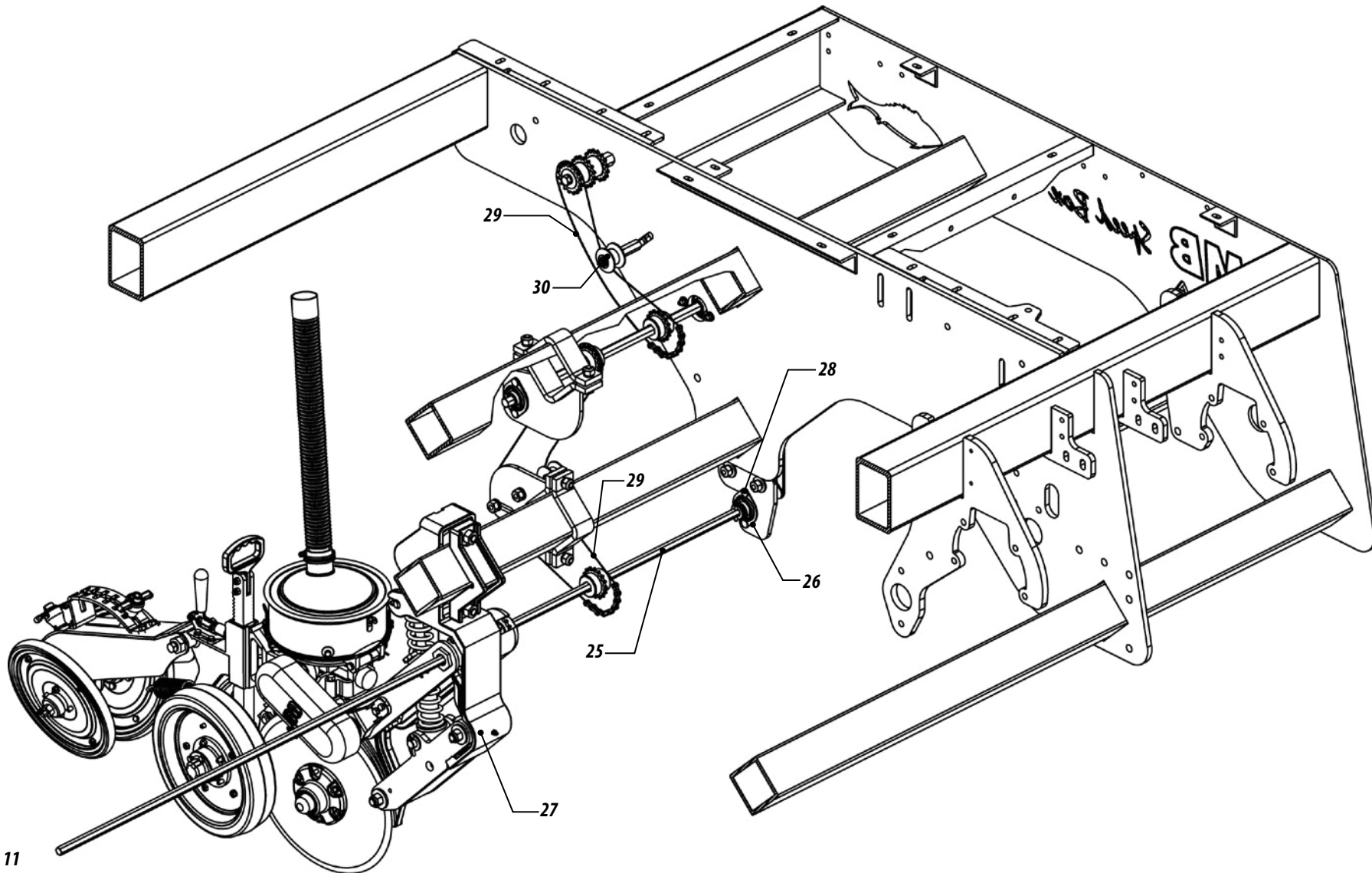
**Figure 11**

05 - TRACTOR COUPLING

- 1- Level the seeder head in relation to the tractor coupling through the regulator (1).
- 2- Couple the seeder to the tractor through the coupling pin (2) place the latch (4). Figure 12.
- 3- Couple the hoses (3) in the tractor coupling.



To this end, find a safe and easily accessible place, always use low gear with low acceleration.



Before connecting or disconnecting the hydraulic hoses, turn off the engine and relieve the pressure of the hydraulic system by moving command levers completely. Make sure that, by relieving the pressure of the system, no one is near the area.

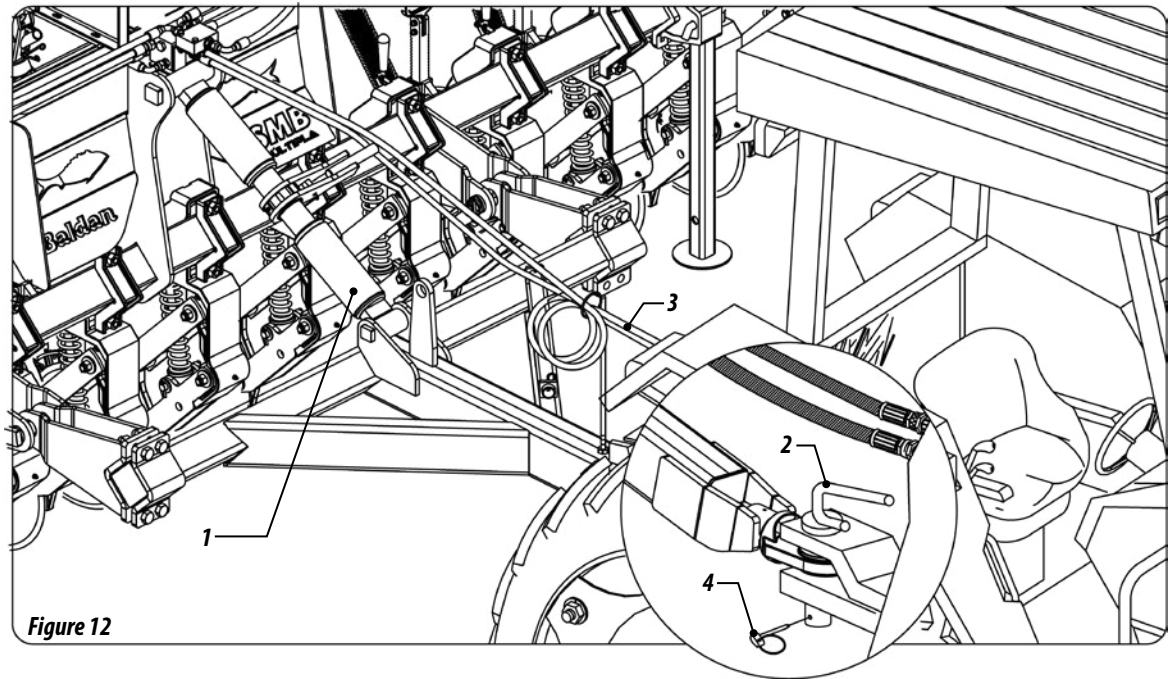

Figure 12

SEEDER TRANSPORT

- 1- Lift the support bracket (1). FIGURE 13.
- 2- With the seeder down, make sure it is at the same level as the tractor. Otherwise, level it through the head regulator (1), Figure 12.
- 3- Raise the lines through the full activation of the hydraulic cylinder. Place the latch (2) on the cylinder rod. Figure 14.



IMPORTANT

Do not carry the seeder if it is loaded, which could damage the equipment. We recommend only load it in the workplace. If the machine is to remain in the field for any reason, we recommend covering it with tarp to prevent moisture.

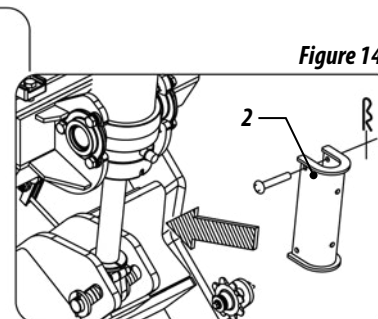
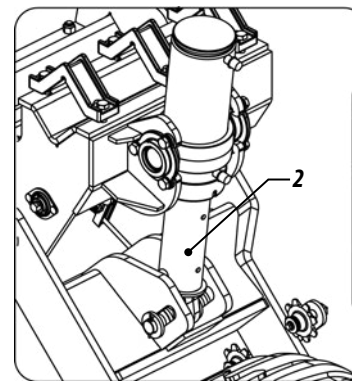
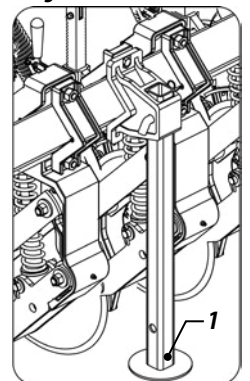

Figure 14

Figure 13



06 - ADJUSTMENTS AND OPERATIONS

NEW SPACING

- 1- To make a new spacing between lines, lift the seeder by pushing the piston.
- 2- Place the support bracket (1) with the locking pin (3). Figure 15.
- 3- Move the hydraulic cylinder again so that the planting lines remain suspended.

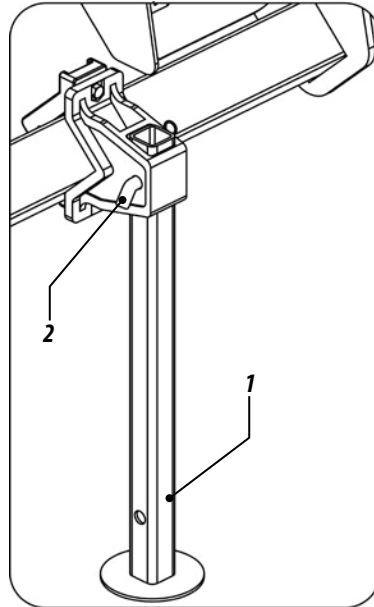

Figure 15

- When making new spacing lines, if necessary remove some of them to increase spacing, proceed as follows;

- 4- Remove the latches (4) from the shaft end (5), on both sides of the machine.
- 5- Check the lines to be removed or displaced. Loosen the nuts and washers (6), screw (7), remove the clamp (8).
- 6- Finally, remove the complete planting lines by pulling them back;
- 7- Replace the shaft (5) and latches (4). Align the gear and retighten the screws.
- 8- Slide the lines for the selected spacing, retighten the nuts of clamps (8).
- 9- Reposition the latches (4) on the sides and retighten the screws. Figure 16.

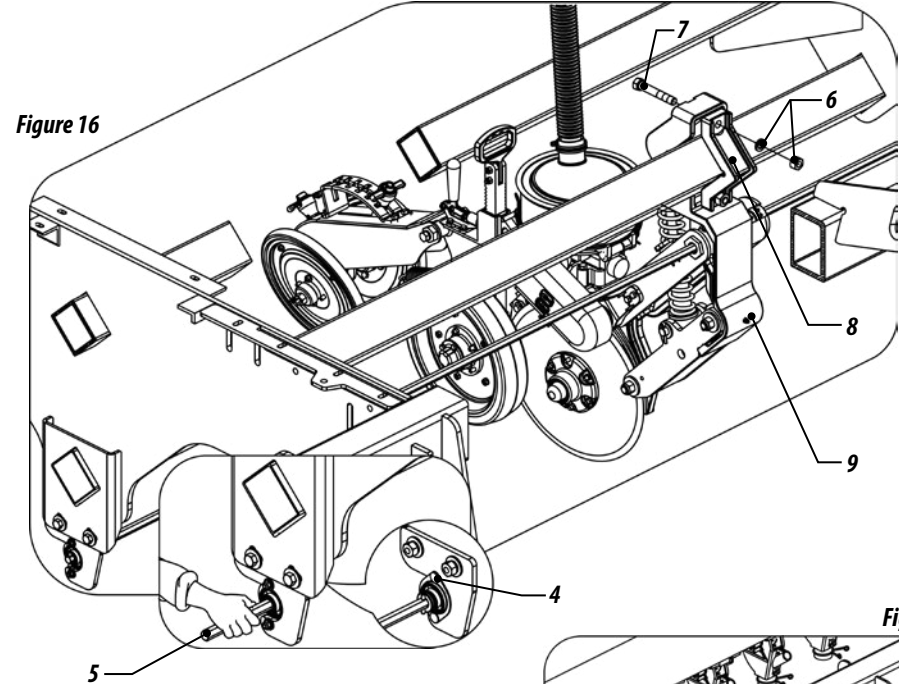

Figure 16

- To make additional spacing lines, proceed as follows:

- 10- Check the lines to be removed or displaced. Loosen the nuts and washers (10), screw (11), remove the clamp (12).
- 11- Slide the lines for the selected spacing. Tighten the nuts of clamps (9). Figure 17.

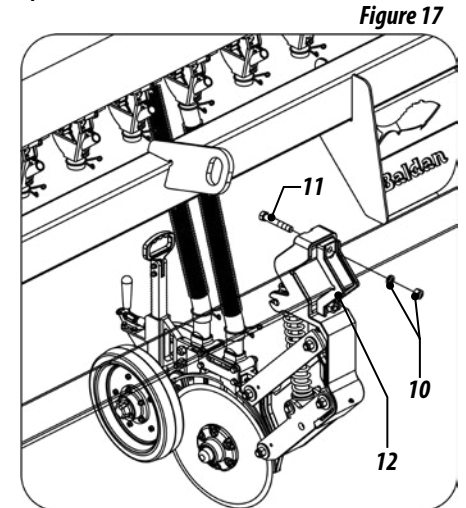
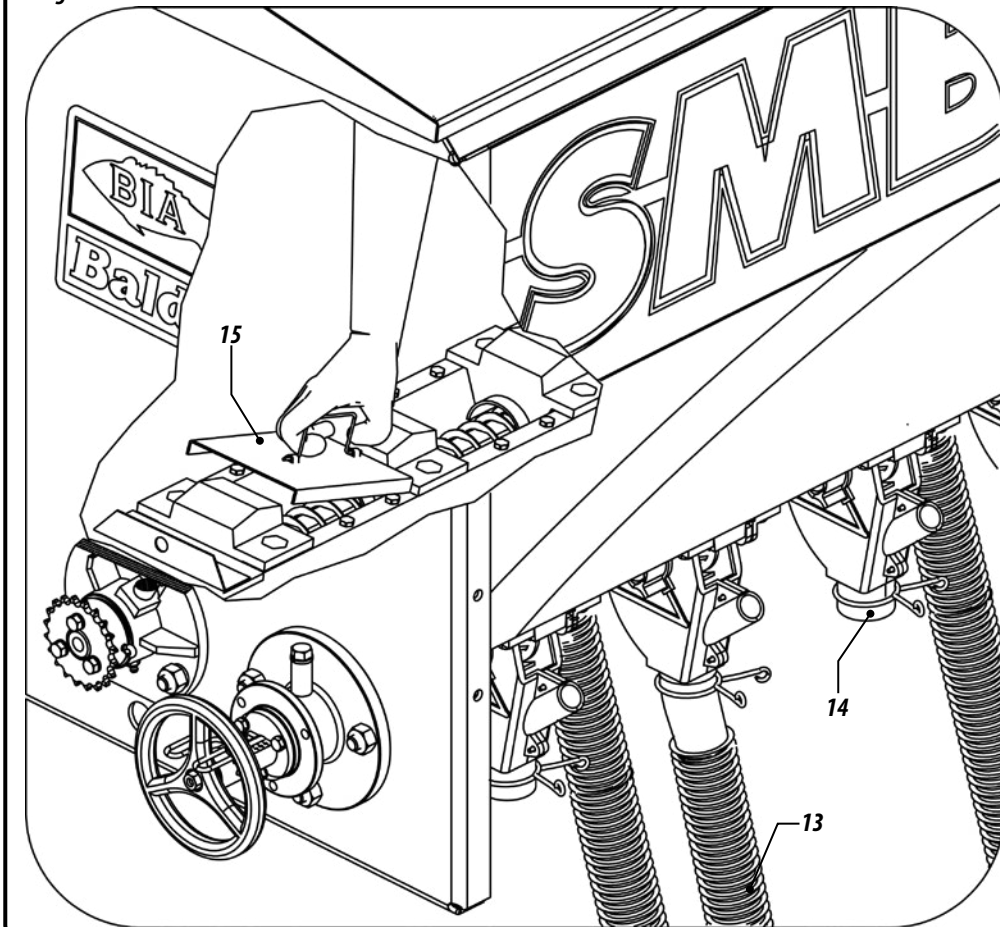

Figure 17

- 12- Remove the small hose that conducts the fertilizer (13) from the lines that were removed, close the outlet of the fertilizer tank with a cover (14).
- 13- Close the input of fertilizer inside the tank by placing the cover (15). Figure 18.

Figure 18



SINGLE SEED TANK

- 14- To transform the single tank only for seeds, remove the plates (16), loosening the screws (17), washers and nuts (18) for the passage of seed between two deposits.
- 15- Place the covers (15) to the fertilizer spout. This will make the tank only for seeds, giving greater autonomy to the machine. Figures 19.

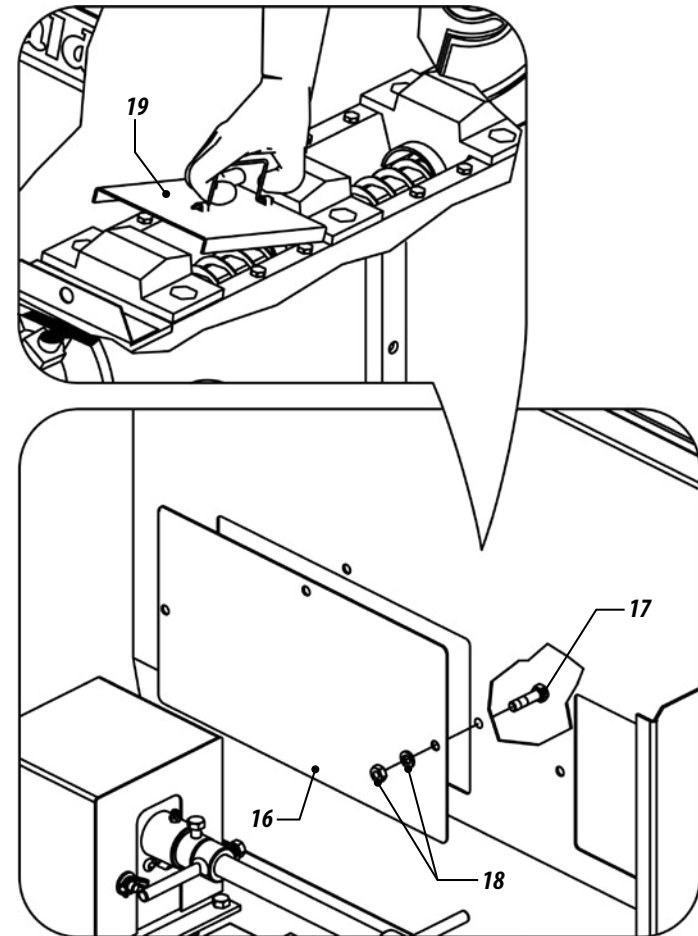

Figure 19

SPACING BETWEEN LINES

1- - The seeders are provided of spacing between lines according to the number of lines, and new types of spacing can be made according to the selected culture.

TABLE OF SPACING - SMALL SEEDS

Table 02

Model	Nr. of Rows	Spacing (mm)	Working width (mm)
4000	13	250	3250
	15	240	3600
	15	230	3450
	15	220	3300
	17	210	3570
	17	200	3400
	17	190	3230
	19	170	3230
	21	165	3465
5000	17	250	4250
	17	240	4080
	17	230	3910
	19	220	4180
	19	210	3990
	21	200	4200
	21	190	3990
	23	170	3910
	25	165	4125
6000	19	250	4750
	19	240	4560
	21	230	4830
	21	220	4620
	23	210	4830
	23	200	4600
	25	190	4750
	27	170	4590
	29	165	4785

TABLE OF SPACING – LARGE SEEDS

Table 03

Model	Nr. of Rows	Spacing (mm)	Working width (mm)
4000	03 / 04	1010	3030 / 4040
	03 / 04	1000	3000 / 4000
	03 / 04	960	2880 / 3840
	03 / 04	950	2850 / 3800
	03 / 04	910	2730 / 3640
	03 / 04	900	2700 / 3600
	03 / 04	860	2580 / 3440
	03 / 04	850	2550 / 3400
	04 / 05	810	3240 / 4050
	04 / 05	800	3200 / 4000
	04 / 05	760	3040 / 3800
	04 / 05	750	3000 / 3750
	04 / 05	700	2800 / 3500
	04 / 05	650	2600 / 3250
	05 / 06	600	3000 / 3600
	06 / 07	550	3000 / 3850
	06 / 07	525	3150 / 3675
	06 / 07	500	3000 / 3500
	08 / 07	450	3600 / 3150
	09 / 08	400	3600 / 3200
10 / 09	350	3500 / 3150	
10 / 11	330	3300 / 3630	
10 / 11	310	3100 / 3410	

TABLE OF SPACING – LARGE SEEDS

Model	Nr. of Rows	Spacing (mm)	Working width (mm)
5000	03 / 04	1010	3030 / 4040
	03 / 04	1000	3000 / 4000
	04 / 05	960	3840 / 4800
	04 / 05	950	3800 / 4750
	04 / 05	910	3640 / 4550
	04 / 05	900	3600 / 4500
	04 / 05	860	3440 / 4300
	04 / 05	850	3400 / 4250
	04 / 05	810	3240 / 4050
	04 / 05	800	3200 / 4000
	05 / 06	760	3800 / 4560
	05 / 06	750	3750 / 4500
	05 / 06	700	3500 / 4200
	06 / 07	650	3900 / 4550
	06 / 07	600	3600 / 4200
	07 / 08	550	3850 / 4400
	07 / 08	525	3675 / 4200
	07 / 08	500	3500 / 4000
	08 / 09	450	3600 / 4050
09 / 10	400	3600 / 4000	
11 / 12	350	3850 / 4200	
11 / 12	330	3630 / 3960	
12 / 13	310	3720 / 4030	

Table 04

Model	Nr. of Rows	Spacing (mm)	Working width (mm)
6000	04 / 05	1010	4040 / 5050
	04 / 05	1000	4000 / 5000
	04 / 05	960	3840 / 4800
	04 / 05	950	3800 / 4750
	04 / 05	910	3640 / 4550
	05 / 06	900	4500 / 5400
	05 / 06	860	4300 / 5160
	05 / 06	850	4250 / 5100
	05 / 06	810	4050 / 4860
	05 / 06	800	4000 / 4800
	05 / 06	760	3800 / 4560
	06 / 07	750	4500 / 5250
	06 / 07	700	4200 / 4900
	07 / 08	650	4550 / 5200
	07 / 08	600	4200 / 4800
	08 / 09	550	4400 / 4950
	08 / 09	525	4200 / 4725
	09 / 10	500	4500 / 5000
	10 / 11	450	4500 / 4950
	10 / 11	420	4200 / 4620
	11 / 12	400	4400 / 4800
12 / 13	350	4200 / 4550	
13 / 14	330	4290 / 4620	
14 / 15	310	4340 / 5100	

Table 05

- 1- - Then, make the new adjustment to the desired spacing on the bar where the seed lines will be set as shown in Figure 20, observing and respecting the useful width of the bar.

Figure 20

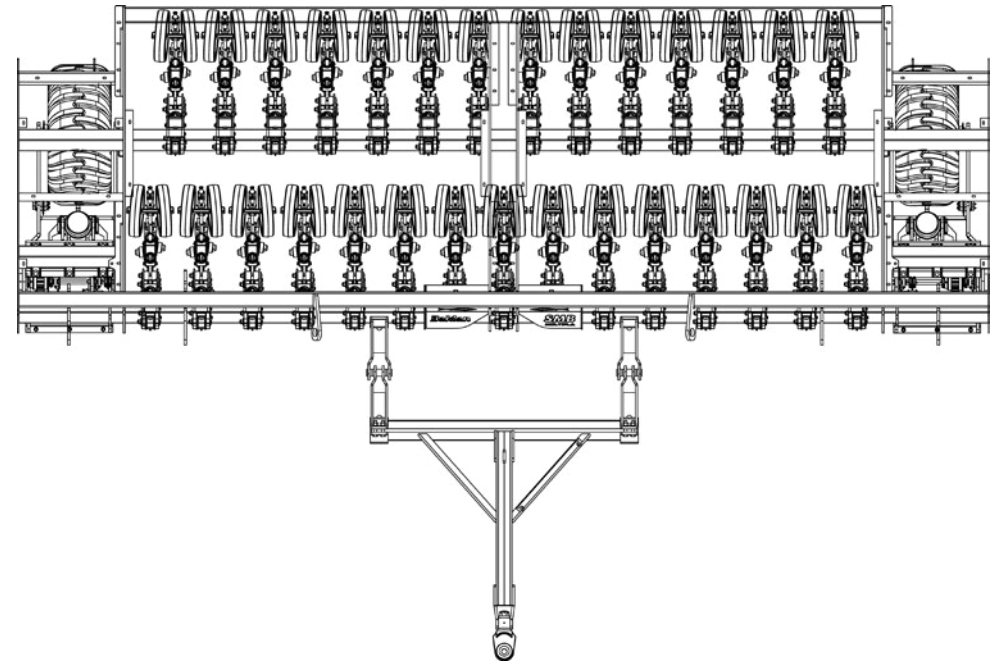

Machine with odd number of lines (seeder)

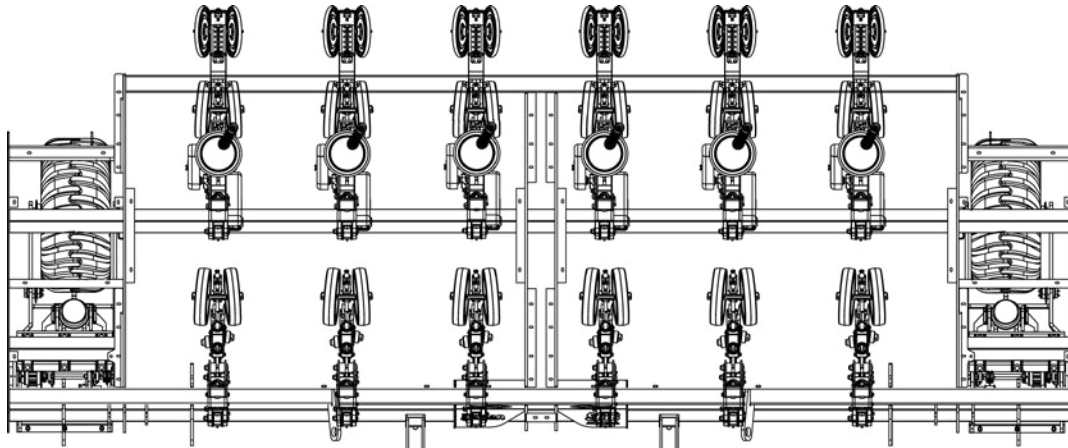

Machine with even number of lines (seeder)

Figures 21

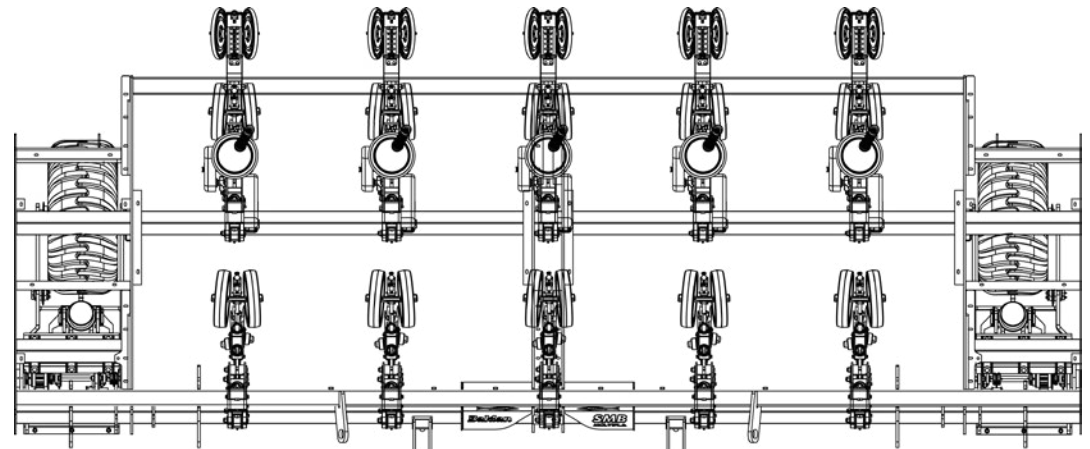

Machine with odd number of lines (seeder)

7 - ADJUSTMENTS FOR SEED DISTRIBUTION

ADJUSTMENT FOR SMALL SEEDS

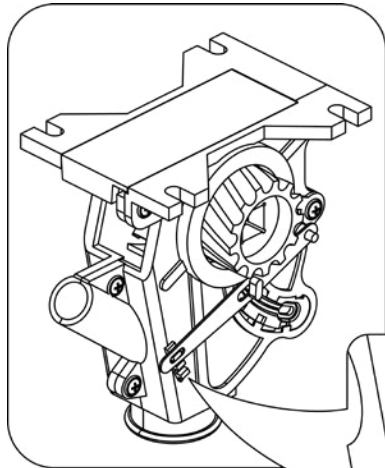

Figure 22

- 1- Adjust the records of the seed distribution boxes for each type of seed and for not to break or cause an irregular seeding. Figure 22.

Regulator 1: Place the record pin (1) in hole 1 of the seed distributor for sowing wheat, sorghum, oats barley, rye and similar seeds.

Regulator 2: Place the record pin (1) in hole 2 of the seed distributor for sowing cotton with no cotton linters, sorghum, soybeans, oats and similar seeds.

Regulator 3: Place the record pin (1) in hole 3 of the seed distributor for sowing rice, oats, peas and similar seeds.

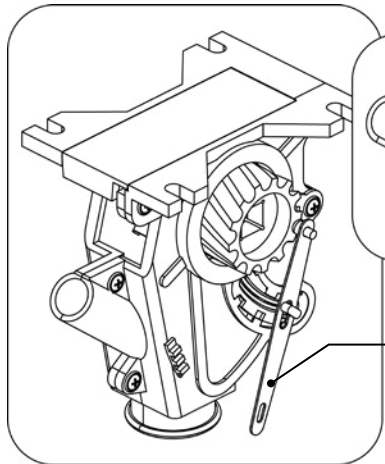
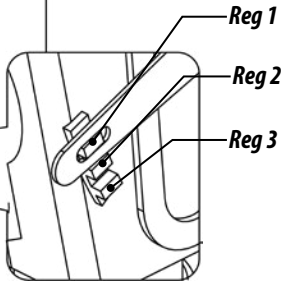
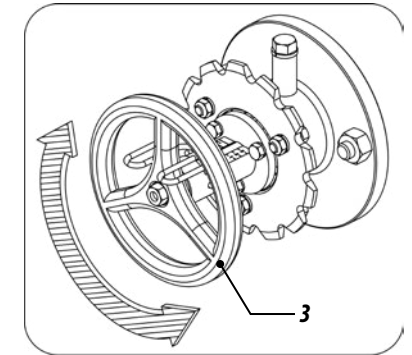
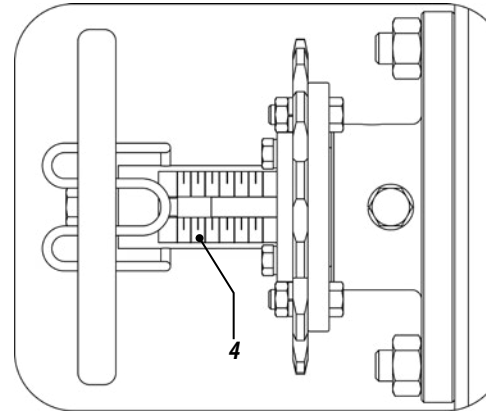

Figure 23

- 2- Pull the lever (1) down to open the hole (2) for the seed output. Figure 23.

- 3- The amount of seed is regulated through the steering wheel (3) of Figure 24.
- 4- Adjust the lever (1) according to the size of each type of seed to be used.



Figures 24

- 5- To obtain the desired adjustment of desired seeds in the distribution boxes, turn the steering wheel (3) in a counterclockwise direction to open the adjustment on the scale (4). Figure 24.

SEED QUANTITY TABLE

Table 06

Culture	No. of seeds per linear meter	Grams of seeds per linear meter	Amount of seeds per hectare	Spacing
Upland rice	40 - 60	1,5 - 2,0	25 - 35	500 - 600
Irrigated rice	60	2,0	30 - 80	300 - 400
Soybeans	25 - 40	-	60	600
Wheat	45 - 60	-	100 - 120	150 - 200
Barley	-	2,0	100 - 140	150 - 200
Oats	-	1,2 - 1,6	60 - 80	200
Sunflower	3 - 5	-	5 - 6	700 - 1000
Sorghum	25	-	10 - 15	700
Lupine	8	-	-	600

ADJUSTMENT OF THE SMALL SEED BOX (OPTIONAL)

- 1- To regulate the distribution of small seeds, do the following;
 - 2- See the table of small seed distribution shown below in the amount of seed required per hectare.
- Example:** To distribute 10 kg / ha seed of colonião grass spaced 170 mm, turn the steering wheel (1) to reach the number of 3.5 of the scale as detail "A". Figure 25.
- 3- Turning the steering wheel to "A" closes the scale.
 - 4- Turning the steering wheel to "B" opens the scale.
- 5- Table of approximate distribution of small seeds per hectare for spacing of 170 mm.

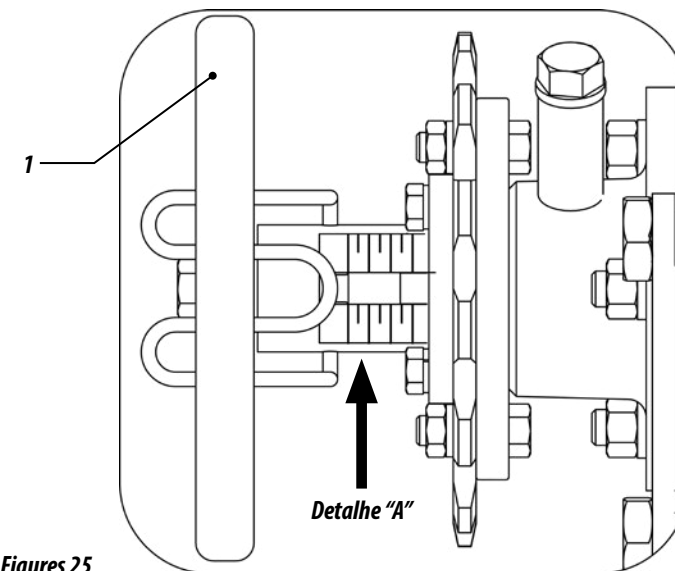

Figures 25

TABLE OF DISTRIBUTION OF PASTURE SEEDS IN KG / HA WITH 170 MM SPACING NUMBER OF THE GROOVED ROTOR OF FIGURE 16

Culture	1	2	3	4	5
<i>Colonião grass</i>	-	12,1	21,8	26,7	31,6
<i>Brachiara decumbens</i>	-	24,3	41,3	53,4	34,0
<i>Brachiara brizantha</i>	-	17,0	34,0	48,5	24,3
<i>Millet</i>	7,3	48,5	77,7	116,5	63,1
<i>Soybeans</i>	8,5	58,2	99,5	143,2	77,7
<i>Alfalfa</i>	9,7	70,4	114,1	157,8	92,2
<i>Birdsfoot trefoil</i>	10,9	72,8	121,3	169,9	97,1
<i>Desmodium</i>	9,2	63,1	104,4	148,0	82,5
<i>Clover</i>	8,7	60,7	101,9	145,6	80,1

Table 07

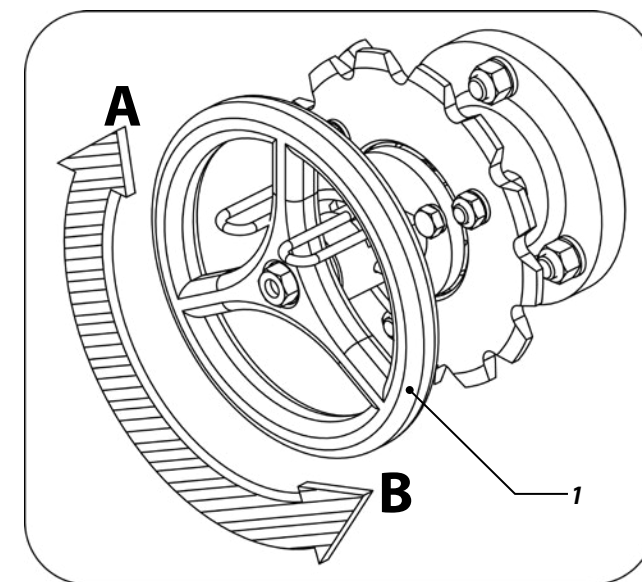

TABLE FOR DISTRIBUTION OF SMALL SEEDS

Table 08

Distribution of seeds in Grams per 100 meters							
Number of the scale in Figure 22							
1	2	3	4	5	6	7	8
Soybean: Average size of 280 seeds per 50 grams							
-	206	578	949	1403	1989	2393	2764
-	248	701	1155	1692	2269	2847	3301
-	309	825	1341	1980	2620	3259	3796
Rice: Average size of 1950 seeds per 50 grams							
-	155	311	466	675	860	1116	1296
-	187	371	559	791	1034	1274	1468
-	203	408	613	876	1155	1434	1658
Wheat: Average size of 1020 seeds per 50 grams							
-	294	587	881	1226	1580	1934	2221
-	335	670	1006	1677	1887	2340	2701
24,3	440	881	1323	1730	2128	2536	2847

To use this table, keep the adjustment of the Speed Box in position F1 - 25-teeth gear and 20-teeth gear of the hexagonal shaft

Figure 26

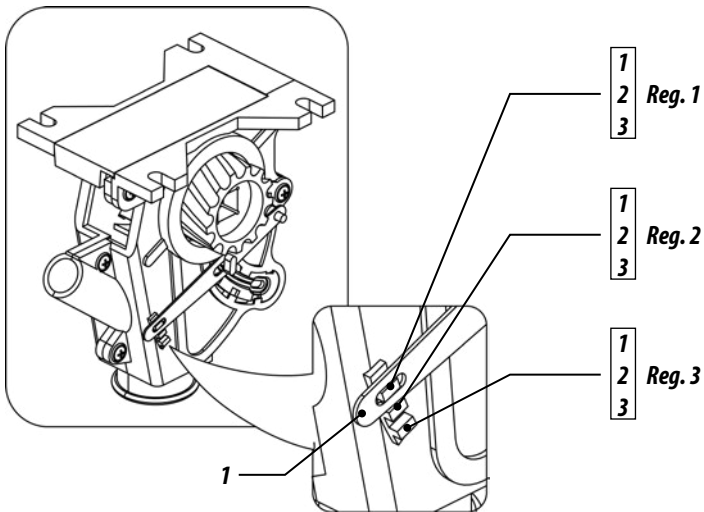

- To obtain the result in Table 06, do the following:
- Know the amount of seed per hectare by multiplying by the spacing and dividing by 100 linear meters.
- Example:** Let's consider 175 kg of wheat seed per hectare, assuming that the average size of the seed to be planted is 1020 seeds equal to 50 grams with spacing of 165 mm at a distance of 100 linear meters.

Formula: $\frac{Q \times E}{D}$

where: Q = amount of seeds
E = spacing between lines
D = 100 linear meters

$$\frac{175 \times 165}{100} = 289 \text{ grams}$$

- The lever (1) for seeds should be placed on the regulator (1) of the seed outlet. Figure 26.
- See page 40 for performing the practical test for seeds and fertilizer.**

ADJUSTMENT OF THE LINE MARKERS

- 1- The adjustment of line markers is important to obtain a planting with uniform spacing, so that the line at the end of the seeder has the same spacing as the last line planted, facilitating future operations. Figure 27.
- 2- To adjust the line markers, one should know the spacing between lines, the number of lines to be used in the operation and the tractor's front gauge. Use the formula below, followed by an example.

Example: For planting with 7 lines, spacing of 0.45 m and tractor's front gauge with 1.73 m, determine:

Formula:
$$D = \frac{E \times (N+1) - B}{2}$$

where: E = spacing between lines

N = Number of lines

B = Tractor's front gauge

D = Distance of the marker

$$D = \frac{0,45 \times 8 - 1,73}{2}$$

D = 0,935 meters

- 3- Adjust the disc with 0.935 m up to the center of the first planting line.
- 4- Line Markers are alternative; they lower one after the other, so that if there is the need to stop work during planting before the end of the line, engage the piston so that the seeder goes up and down twice to continue working with the marker on the right side.

Figure 27

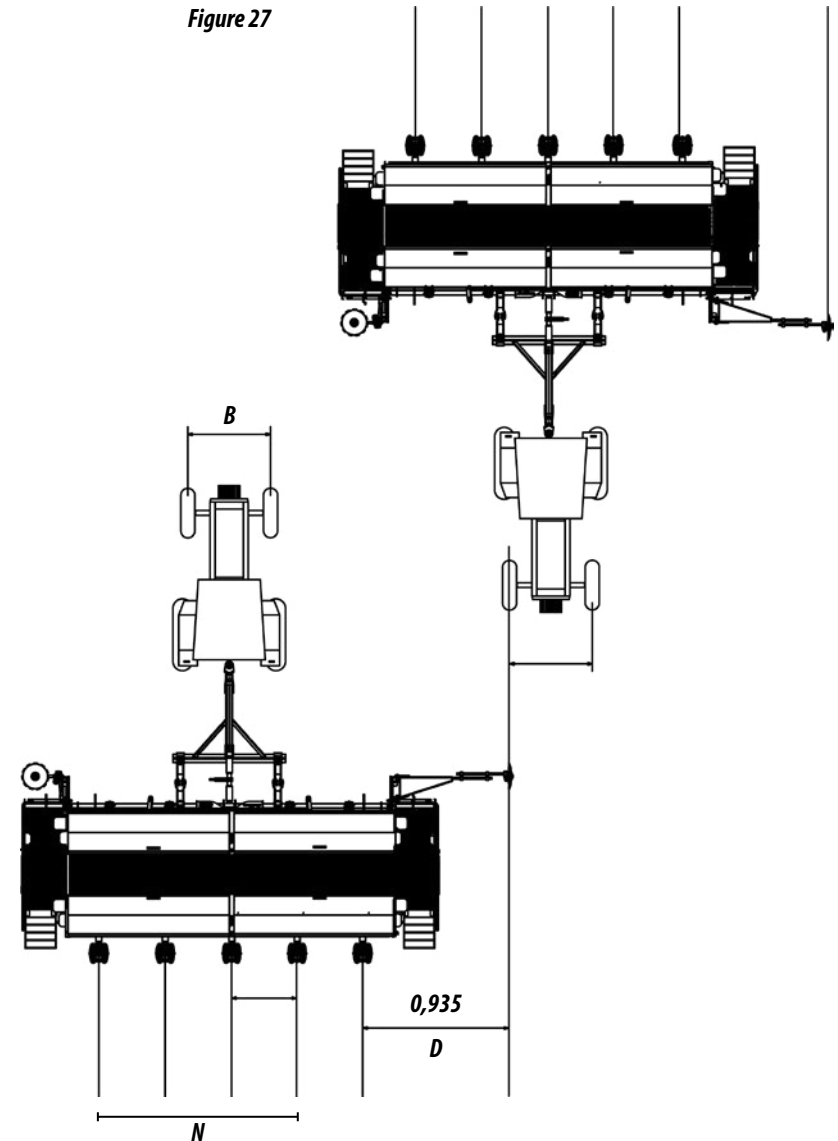

08 - ADJUSTMENT FOR SEED DISTRIBUTION - UNIVERSAL SYSTEM

ADJUSTMENT FOR LARGE SEE

- 1- To exchange or replace the distribution discs, release the latch (1) by pulling it back and lifting the seed box (2).
- 2- Then, replace the disc (3) and the ring (4). Figures 28.

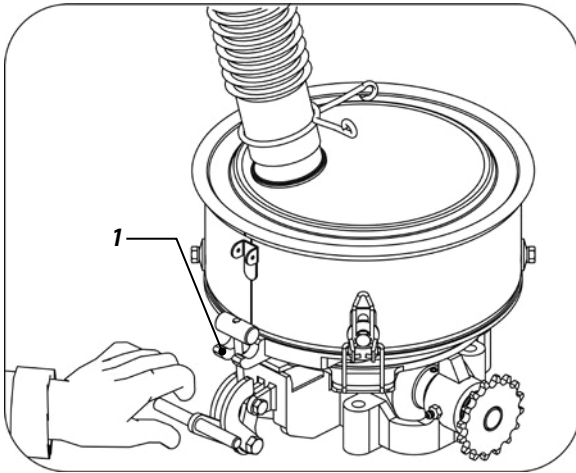

Figures 28

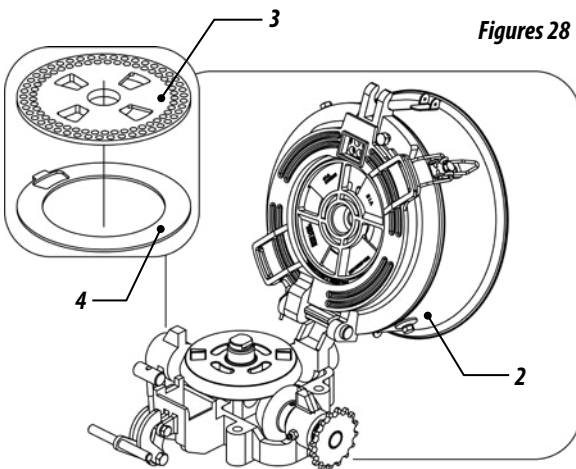

- 3- Select the desired distribution disc and assemble it on the seed box. Check the placement of the rings according to the distribution seed disc as follows;
- 4- To distribution disc of 4.00 mm, use a plastic ring of 4.50 mm.
- 5- To distribution disc of 5.50 mm, use a plastic ring of 3.00 mm. Figures 29.

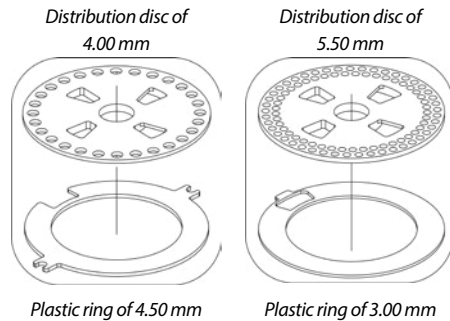

Figures 29

Note: The sum of all seed discs and rings must be equal to 8.5 mm.

SEED DOSING STAR

- 1- The seed distributor comes from the factory assembled with trigger of two dosing stars on discs of double line of holes (2).
- 2- Single line discs (3) use trigger of a single dosing star (4). In order to replace the triggers, see FIGURE 30.

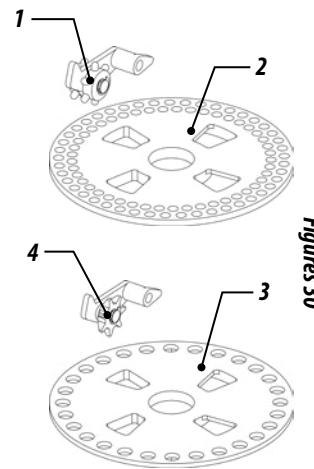

Figures 30

REPLACEMENT OF DOUBLE TRIGGER BY SINGLE TRIGGER

- 3- The seed distributor comes from the factory assembled with trigger of two dosing stars (1) on discs of double line of holes. To replace it for trigger of a single star (2), remove the pin (3), the trigger (1), place the spring (4) in the slot, insert the trigger (2) in the box (5) and lock with the pin (3).

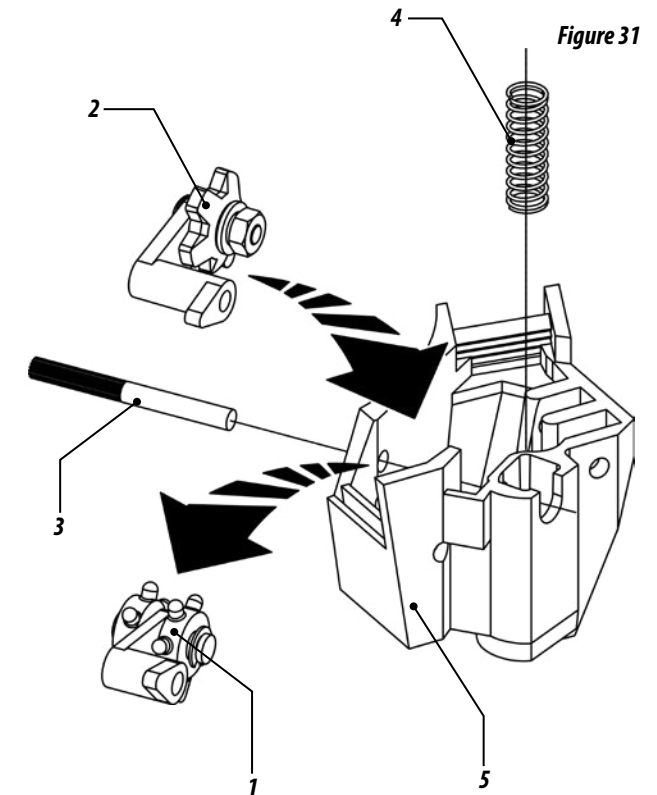

Figure 31

SPEED BOX GEARBOX

- 1- The seeders are equipped with the Speed Box gearbox system that drives the distribution system with easy adjustments, ensuring exchange of fast rotations.
- 2- For seed regulation, select the desired quantity in the tables and check the corresponding combination of cursors (1). Example: position F 6 indicates that the cursor of letters must be in position "F" and the cursor of numbers must be in position "6" as detailed in Figure 32.
- 3- To move the cursor, remove the lock (2), pull the handle (3) and adjust them. At the end of the combination, return the handle (3) and replace the lock (2).

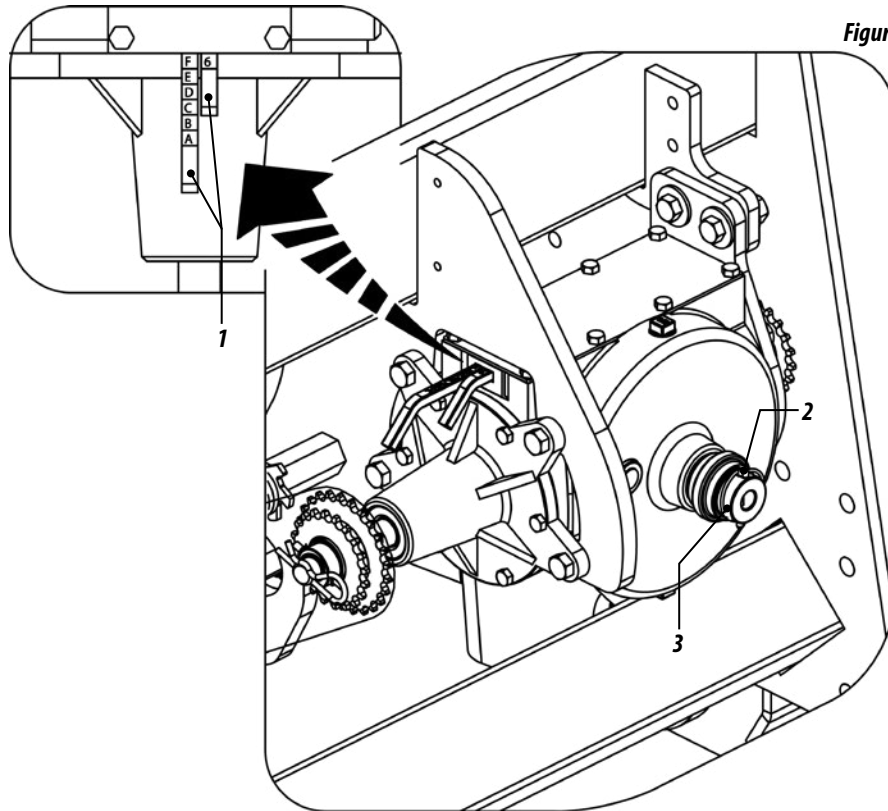

Figure 32

09 - ADJUSTMENT FOR THE DISTRIBUTION OF LARGE SEEDS

- 4- The seed adjustment is performed through the Speed Box. For other adjustments, re-position the chain in motor gear "a" and moved gear "b".
- 5- After repositioning, check the chain tension.
- 6- 6 – The chain tensioner (1) is provided of torsion spring for greater flexibility. In case of greater pressure on the stretcher, turn the rosette (2) through the spring coupler (3) to the other tooth of the rosette. Figure 33.

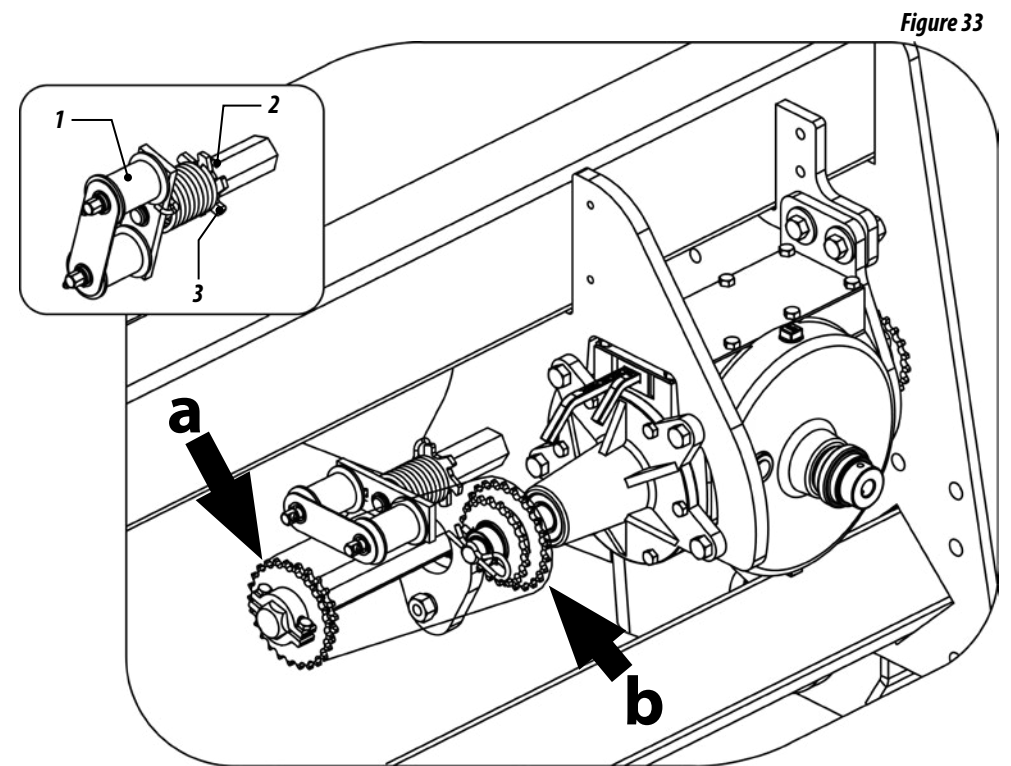
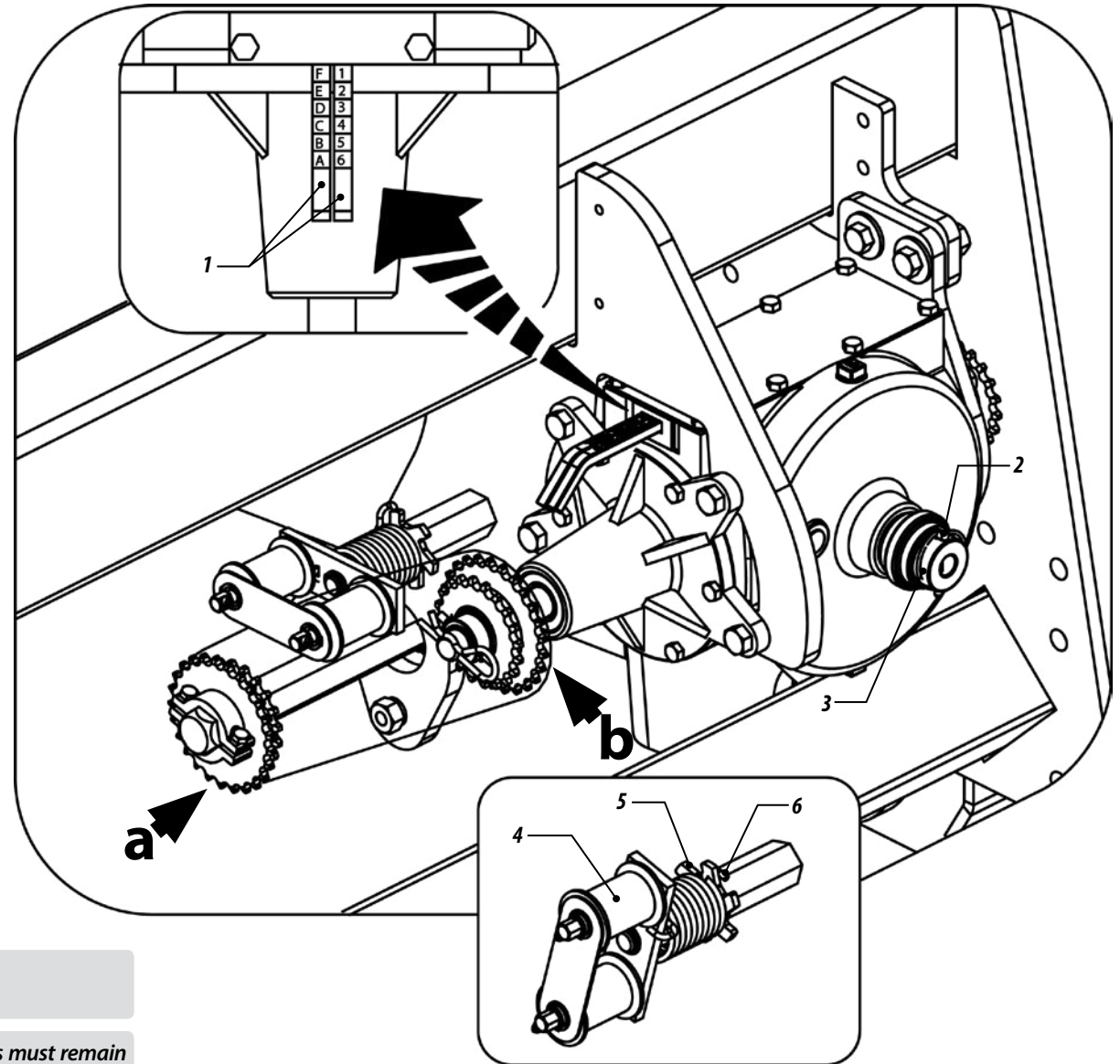

Figure 33

10 - ADJUSTMENT FOR THE DISTRIBUTION OF SMALL SEEDS

- 1- The seeders are equipped with the Speed Box system, which operates the distribution system with easy adjustments, ensuring quick exchange of rotations.
- 2- To put the levers (1) to position "F 1", remove the lock (2), pull the handle (3), and set them. At the end of the combination, return the handle (3) and replace the lock (2).
- 3- The seed adjustment is done through the Speed Box. To do so, re-position the chain in the 20-teeth gear "a" of the ratchet shaft and 25-teeth moved gear "b" of the Speed Box.
- 4- After repositioning, check the chain tension.
- 5- The tensioner (4) is equipped with torsion spring to provide greater flexibility, if greater pressure on the tensioner is required, turn the rosette (5) through the spring coupler (6) to the other tooth of the rosette. Figure 34.



IMPORTANT

When operating the SMB in the seeder system – small seeds- the Speed Box levers must remain only in the working position "F1".



TABLE FOR THE DISTRIBUTION OF LARGE SEEDS PER LINEAR METER – SMB SEEDER – SPEED BOX 4000 / 5000 / 6000

Table 09

Combination	Outlet gear of the ratchet shaft							20	Inlet gear of the Speed Box							25	
	Number of holes in the disc																
	17	18	19	20	24	26	28	30	38	40	48	50	62	64	72	90	100
F-1	1,5	1,6	1,7	1,7	2,1	2,3	2,4	2,6	3,3	3,5	4,2	4,4	5,4	5,6	6,3	7,9	8,7
F-2	1,7	1,8	1,9	2,0	2,4	2,6	2,8	2,9	3,7	3,9	4,7	4,9	6,1	6,3	7,1	8,8	9,8
E-1	1,9	2,0	2,1	2,2	2,6	2,8	3,1	3,3	4,2	4,4	5,2	5,5	6,8	7,0	7,9	9,8	10,9
F-3	1,9	2,0	2,1	2,2	2,7	2,9	3,1	3,4	4,3	4,5	5,4	5,6	7,0	7,2	8,1	10,1	11,2
E-2	2,1	2,2	2,3	2,5	2,9	3,2	3,4	3,7	4,7	4,9	5,9	6,1	7,6	7,9	8,8	11,1	12,3
D-1	2,2	2,4	2,5	2,6	3,1	3,4	3,7	3,9	5,0	5,2	6,3	6,6	8,1	8,4	9,4	11,8	13,1
F-4	2,2	2,4	2,5	2,6	3,1	3,4	3,7	3,9	5,0	5,2	6,3	6,6	8,1	8,4	9,4	11,8	13,1
E-3	2,4	2,5	2,7	2,8	3,4	3,7	3,9	4,2	5,3	5,6	6,7	7,0	8,7	9,0	10,1	12,6	14,0
D-2	2,5	2,7	2,8	2,9	3,5	3,8	4,1	4,4	5,6	5,9	7,1	7,4	9,1	9,4	10,6	13,3	14,7
C-1	2,6	2,8	2,9	3,1	3,7	4,0	4,3	4,6	5,8	6,1	7,3	7,6	9,5	9,8	11,0	13,8	15,3
F-5	2,7	2,8	3,0	3,1	3,8	4,1	4,4	4,7	6,0	6,3	7,5	7,9	9,8	10,1	11,3	14,2	15,7
E-4	2,8	2,9	3,1	3,3	3,9	4,3	4,6	4,9	6,2	6,6	7,9	8,2	10,2	10,5	11,8	14,7	16,4
D-3	2,9	3,0	3,2	3,4	4,0	4,4	4,7	5,1	6,4	6,7	8,1	8,4	10,4	10,8	12,1	15,2	16,9
C-2	2,9	3,1	3,3	3,4	4,1	4,5	4,8	5,2	6,5	6,9	8,3	8,6	10,7	11,0	12,4	15,5	17,2
B-1	3,0	3,1	3,3	3,5	4,2	4,5	4,9	5,2	6,6	7,0	8,4	8,7	10,8	11,2	12,6	15,7	17,5
A-1	3,3	3,5	3,7	3,9	4,7	5,1	5,5	5,9	7,5	7,9	9,4	9,8	12,2	12,6	14,2	17,7	19,7
A-2	3,8	4,0	4,2	4,4	5,3	5,8	6,2	6,6	8,4	8,8	10,6	11,1	13,7	14,2	15,9	19,9	22,1
B-3	3,8	4,0	4,3	4,5	5,4	5,8	6,3	6,7	8,5	9,0	10,8	11,2	13,9	14,4	16,2	20,2	22,5
C-4	3,9	4,1	4,4	4,6	5,5	6,0	6,4	6,9	8,7	9,2	11,0	11,5	14,2	14,7	16,5	20,6	22,9
D-5	4,0	4,2	4,5	4,7	5,7	6,1	6,6	7,1	9,0	9,4	11,3	11,8	14,6	15,1	17,0	21,2	23,6
E-6	4,2	4,4	4,7	4,9	5,9	6,4	6,9	7,4	9,3	9,8	11,8	12,3	15,2	15,7	17,7	22,1	24,6
A-3	4,3	4,5	4,8	5,1	6,1	6,6	7,1	7,6	9,6	10,1	12,1	12,6	15,7	16,2	18,2	22,7	25,3
B-4	4,5	4,7	5,0	5,2	6,3	6,8	7,3	7,9	10,0	10,5	12,6	13,1	16,3	16,8	18,9	23,6	26,2
C-5	4,7	5,0	5,2	5,5	6,6	7,2	7,7	8,3	10,5	11,0	13,2	13,8	17,1	17,6	19,8	24,8	27,5
D-6	5,0	5,3	5,6	5,9	7,1	7,7	8,3	8,8	11,2	11,8	14,2	14,7	18,3	18,9	21,2	26,5	29,5
A-4	5,0	5,3	5,6	5,9	7,1	7,7	8,3	8,8	11,2	11,8	14,2	14,7	18,3	18,9	21,2	26,5	29,5
B-5	5,3	5,7	6,0	6,3	7,5	8,2	8,8	9,4	12,0	12,6	15,1	15,7	19,5	20,0	22,6	28,3	31,5
C-6	5,8	6,2	6,5	6,9	8,3	8,9	9,6	10,3	13,1	13,8	16,5	17,2	21,3	22,0	24,8	31,0	34,4
A-5	6,0	6,4	6,7	7,1	8,5	9,2	9,9	10,6	13,4	14,2	17,0	17,7	21,9	22,6	25,5	31,8	35,4
B-6	6,7	7,1	7,5	7,9	9,4	10,2	11,0	11,8	14,9	15,7	18,9	19,7	24,4	25,2	28,3	35,4	39,3
A-6	7,5	8,0	8,4	8,8	10,6	11,5	12,4	13,3	16,8	17,7	21,2	22,1	27,4	28,3	31,8	39,8	44,2

TABLE FOR THE DISTRIBUTION OF SMALL SEEDS PER LINEAR METER – SMB SEEDER – SPEED BOX 4000 / 5000 / 6000

Table 10

Combination	Outlet gear of the ratchet shaft							25	Inlet gear of the Speed Box							20	
	Number of holes in the disc																
	17	18	19	20	24	26	28	30	38	40	48	50	62	64	72	90	100
F-1	2,3	2,5	2,6	2,7	3,3	3,5	3,8	4,1	5,2	5,5	6,6	6,8	8,5	8,7	9,8	1,3	13,7
F-2	2,6	2,8	2,9	3,1	3,7	4,0	4,3	4,6	5,8	6,1	7,4	7,7	9,5	9,8	11,1	13,8	15,4
E-1	2,9	3,1	3,2	3,4	4,1	4,4	4,8	5,1	6,5	6,8	8,2	8,5	10,6	10,9	12,3	15,4	17,1
F-3	3,0	3,2	3,3	3,5	4,2	4,6	4,9	5,3	6,7	7,0	8,4	8,8	10,9	11,2	12,6	15,8	17,6
E-2	3,3	3,5	3,6	3,8	4,6	5,0	5,4	5,8	7,3	7,7	9,3	9,6	11,9	12,3	13,8	17,3	19,2
D-1	3,5	3,7	3,9	4,1	4,9	5,3	5,7	6,1	7,8	8,2	9,8	10,2	12,7	13,1	14,7	18,4	20,5
F-4	3,5	3,7	3,9	4,1	4,9	5,3	5,7	6,1	7,8	8,2	9,8	10,2	12,7	13,1	14,7	18,4	20,5
E-3	3,7	3,9	4,2	4,4	5,3	5,7	6,1	6,6	8,3	8,8	10,5	11,0	13,6	14,0	15,8	19,7	21,9
D-2	3,9	4,1	4,4	4,6	5,5	6,0	6,5	6,9	8,8	9,2	11,1	11,5	14,3	14,7	16,6	20,7	23,0
C-1	4,1	4,3	4,5	4,8	5,7	6,2	6,7	7,2	9,1	9,6	11,5	11,9	14,8	15,3	17,2	21,5	23,9
F-5	4,2	4,4	4,7	4,9	5,9	6,4	6,9	7,4	9,3	9,8	11,8	12,3	15,2	15,7	17,7	22,1	24,6
E-4	4,4	4,6	4,9	5,1	6,1	6,7	7,2	7,7	9,7	10,2	12,3	12,8	15,9	16,4	18,4	23,0	25,6
D-3	4,5	4,7	5,0	5,3	6,3	6,8	7,4	7,9	10,0	10,5	12,6	13,2	16,3	16,9	19,0	23,7	26,3
C-2	4,6	4,8	5,1	5,4	6,5	7,0	7,5	8,1	10,2	10,8	12,9	13,4	16,7	17,2	19,4	24,2	26,9
B-1	4,6	4,9	5,2	5,5	6,6	7,1	7,6	8,2	10,4	10,9	13,1	13,7	16,9	17,5	19,7	24,6	27,3
A-1	5,2	5,5	5,8	6,1	7,4	8,0	8,6	9,2	11,7	12,3	14,7	15,4	19,0	19,7	22,1	27,6	30,7
A-2	5,9	6,2	6,6	6,9	8,3	9,0	9,7	10,4	13,1	13,8	16,6	17,3	21,4	22,1	24,9	31,1	34,6
B-3	6,0	6,3	6,7	7,0	8,4	9,1	9,8	10,5	13,3	14,0	16,9	17,6	21,8	22,5	25,3	31,6	35,1
C-4	6,1	6,5	6,8	7,2	8,6	9,3	10,0	10,8	13,6	14,3	17,2	17,9	22,2	22,9	25,8	32,3	35,8
D-5	6,3	6,6	7,0	7,4	8,8	9,6	10,3	11,1	14,0	14,7	17,7	18,4	22,9	23,6	26,5	33,2	36,9
E-6	6,5	6,9	7,3	7,7	9,2	10,0	10,8	11,5	14,6	15,4	18,4	19,2	23,8	24,6	27,6	34,6	38,4
A-3	6,7	7,1	7,5	7,9	9,5	10,3	11,1	11,8	15,0	15,8	19,0	19,7	24,5	25,3	28,4	35,5	39,5
B-4	7,0	7,4	7,8	8,2	9,8	10,6	11,5	12,3	15,6	16,4	19,7	20,5	25,4	26,2	29,5	36,9	41,0
C-5	7,3	7,7	8,2	8,6	10,3	11,2	12,0	12,9	16,3	17,2	20,6	21,5	26,7	27,5	31,0	38,7	43,0
D-6	7,8	8,3	8,8	9,2	11,1	12,0	12,9	13,8	17,5	18,4	22,1	23,0	28,6	29,5	33,2	41,5	46,1
A-4	7,8	8,3	8,8	9,2	11,1	12,0	12,9	13,8	17,5	18,4	22,1	23,0	28,6	29,5	33,2	41,5	46,1
B-5	8,4	8,8	9,3	9,8	11,8	12,8	13,8	14,7	18,7	19,7	23,6	24,6	30,5	31,5	35,4	44,2	49,1
C-6	9,1	9,7	10,2	10,8	12,9	14,0	15,1	16,1	20,4	21,5	25,8	26,9	33,3	34,4	38,7	48,4	53,8
A-5	9,4	10,0	10,5	11,1	13,3	14,4	15,5	16,6	21,0	22,1	26,5	27,6	34,3	35,4	39,8	49,8	55,3
B-6	10,4	11,1	11,7	12,3	14,7	16,0	17,2	18,4	23,3	24,6	29,5	30,7	38,1	39,3	44,2	55,3	61,4
A-6	11,7	12,4	13,1	13,8	16,6	18,0	19,4	20,7	26,3	27,6	33,2	34,6	42,8	44,2	49,8	62,2	69,1

FERTILIZER DISTRIBUTION SYSTEM METAL AND STAINLESS STEEL TANK

- 1- The floating spiral fertilizer distribution system consists of a shaft arranged at the bottom of the fertilizer tank that when it starts turning, the fertilizer involves the shaft, which distributes it, avoiding the use of intermediate bearings.
- 2- In determining the number of lines and desired spacing, attach the small hoses (1) to the fertilizer spout (2), making the connection of the hoses that are close to the lines, preventing them from becoming folded, as in Figure 35.
- 3- The outlets that will not be used must be sealed with lids (3) inside the tank and with the cap (4) in the external outlets; this will prevent fine fertilizer particles to fall on the seeder.
- 4- The floating spiral fertilizer dispenser system has several safety outputs, which, upon entering the fertilizer dosimeter and some output is blocked, it will begin leaking through the safety output "A", thus ensuring operating the system without damaging it. If this occurs, clean the fertilizer dosimeter up to the spout located on the double disc or plow rod, since clogging can occur due to the presence of roots, plastic pieces and other objects.

Figure 35

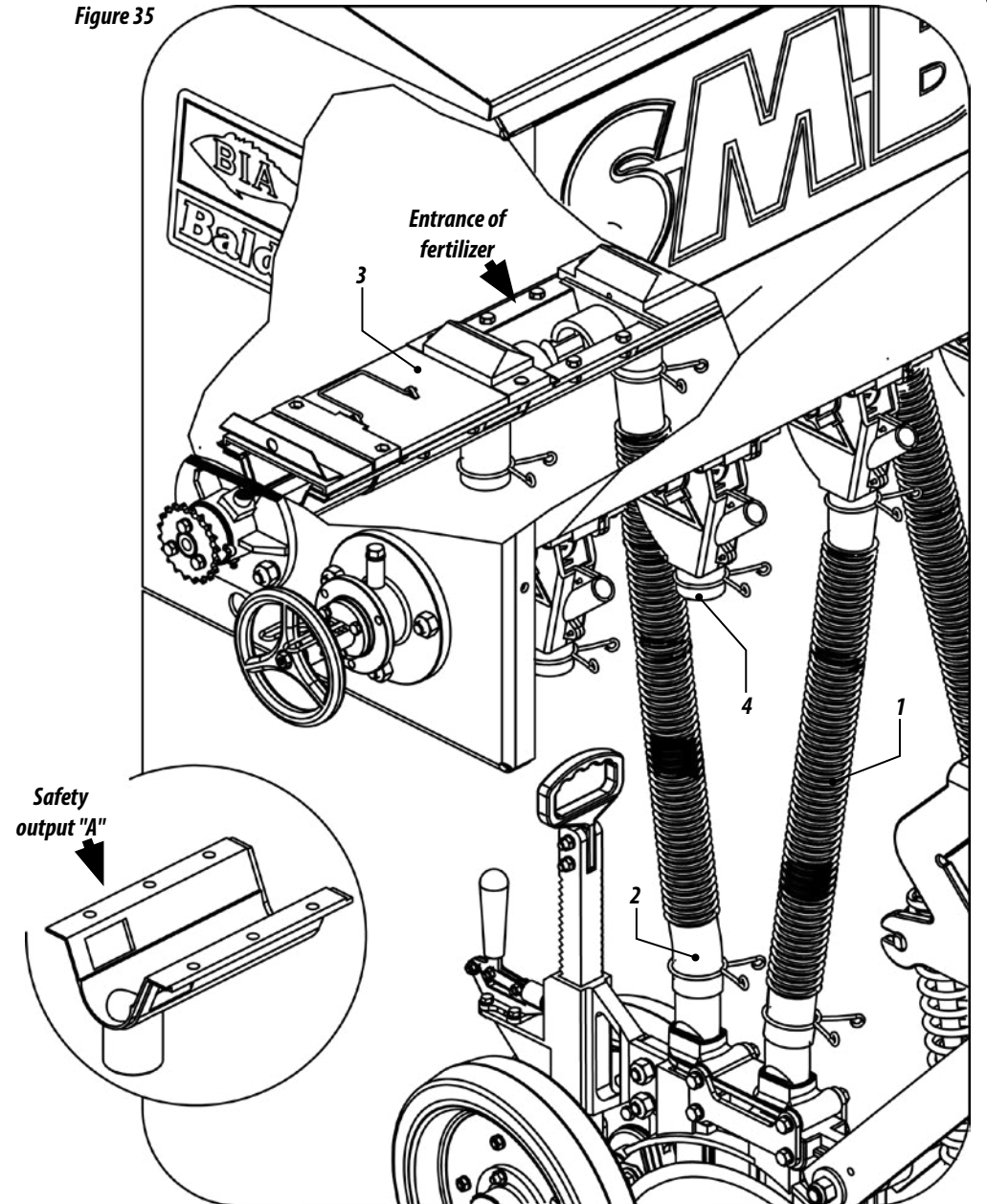

IMPORTANT

Remove the caps (4) periodically and clean their output. When the fertilizer is wet or has impurities, make the cleaning more often.

SPEED BOX SYSTEM

- 1- The seeders are equipped with the Speed Box system, which operates the distribution system, with simple adjustments, ensuring fast and practical exchange of rotations.
- 2- For fertilizer adjustments, select the desired quantity in tables and check the corresponding combination of cursors (1). Example: position F2 indicates that the cursor with letters must be at position "F" and the cursor with numbers must be at position "2" as shown in Figure 36.
- 3- To move the cursor, remove the lock (2), pull the handle (3) and set them. At the end of the combination, return the handle (3) and replace the lock (2).

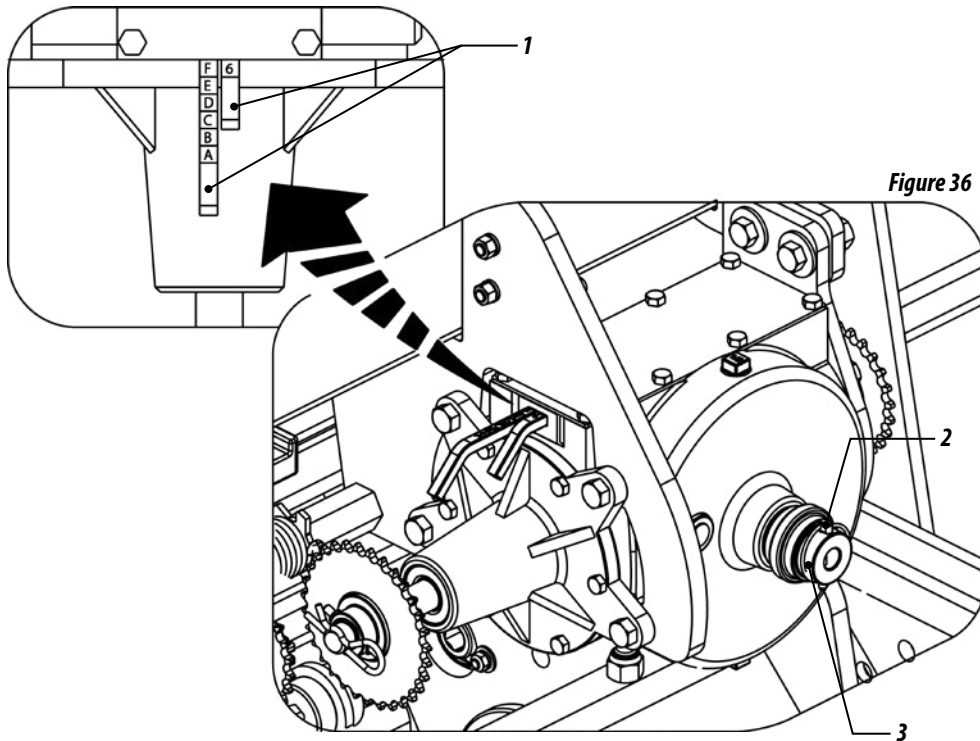

Figure 36

11 - ADJUSTMENT FOR FERTILIZER DISTRIBUTION

- 4- The fertilizer adjustment is made through the Speed Box. For other adjustments, re-position the chain in motor gear "a" and moved gear "b".
- 5- After the repositioning of the gears, check the chain tension.
- 6- The tensioner (1) is provided with a tension spring for greater flexibility, and for greater pressure on the tensioner, turn the rosette (2) through the spring coupler (3) to the other tooth of the rosette. Figure 37.

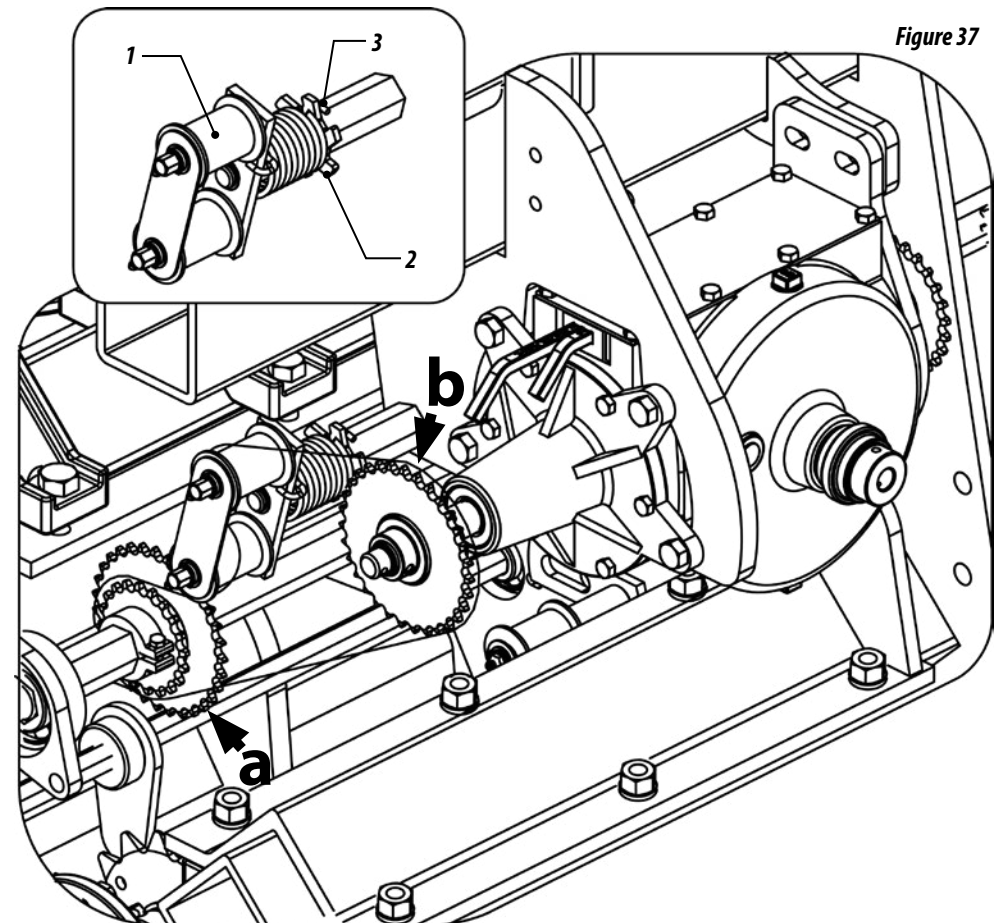

Figure 37

TABLE FOR FERTILIZER DISTRIBUTION– SMB SEEDER – SPEED BOX 4000 / 5000 / 6000

Table 12

Combination	Grams / 50m	Outlet gear of the ratchet shaft															Inlet gear of the Speed Box	
		Spacing between lines																
		165	170	190	310	340	400	450	500	550	600	650	700	750	800	850	900	950
F-1	191	232	225	201	123	113	96	85	77	70	64	59	55	51	48	45	43	40
F-2	215	261	253	227	139	127	108	96	86	78	72	66	62	57	54	51	48	45
E-1	239	290	281	252	154	141	120	106	96	87	80	74	68	64	60	56	53	50
F-3	246	298	289	259	159	145	123	109	98	89	82	76	70	66	62	58	55	52
E-2	269	326	317	282	174	158	135	120	108	98	90	83	77	72	67	63	60	57
D-1	287	348	338	302	185	169	144	128	115	104	96	88	82	77	72	68	64	60
F-4	287	348	338	302	185	169	144	128	115	104	96	88	82	77	72	68	64	60
E-3	308	373	362	324	198	181	154	137	123	112	103	95	88	82	77	72	68	65
D-2	323	391	380	340	208	190	161	144	129	117	108	99	92	86	81	76	72	68
C-1	335	406	394	352	216	197	167	149	134	122	112	103	96	89	84	79	74	70
F-5	344	417	405	363	222	203	172	153	138	125	115	106	98	92	86	81	77	73
E-4	359	435	422	378	231	211	179	159	144	130	120	110	103	96	90	84	80	76
D-3	369	447	434	388	238	217	185	167	148	134	123	114	105	98	92	87	82	78
C-2	377	457	443	397	243	222	188	167	151	137	126	116	108	100	94	89	84	79
B-1	383	464	450	403	247	225	191	170	153	139	128	118	109	102	96	90	85	81
A-1	431	522	506	453	278	253	215	191	172	157	144	132	123	115	108	101	96	91
A-2	484	587	570	510	312	285	242	215	194	176	161	149	138	129	121	114	108	102
B-3	492	596	579	518	317	289	246	219	197	179	164	151	141	131	123	116	109	104
C-4	502	609	591	529	324	295	251	223	201	183	167	155	144	134	126	118	112	106
D-5	517	626	608	544	333	304	258	230	207	188	172	159	148	138	129	122	115	109
E-6	538	652	633	566	347	317	269	239	215	196	179	166	154	144	135	127	120	113
A-3	554	671	651	583	357	326	277	246	221	201	185	170	158	148	138	130	123	117
B-4	574	696	675	604	370	338	287	255	230	209	191	177	164	153	144	135	128	121
C-5	603	731	709	634	389	355	301	268	241	219	201	185	172	161	151	142	134	127
D-6	646	783	760	680	417	380	323	287	258	235	215	199	185	172	161	152	144	136
A-4	646	783	760	680	417	380	323	287	258	235	215	199	185	172	161	152	144	136
B-5	689	835	810	725	444	405	344	306	276	250	230	212	197	184	182	162	153	145
C-6	753	913	886	793	486	443	377	335	301	275	251	232	215	201	188	177	167	159
A-5	775	939	912	816	500	456	387	344	310	282	258	238	221	107	194	182	172	163
B-6	861	1044	1013	906	555	506	431	383	344	313	287	265	246	230	245	203	191	181
A-6	969	1174	1140	1020	625	570	484	431	387	352	323	298	277	258	242	228	215	204

References: Table elaborated by using 1 inch step spring for fertilizer distribution with density of 1 liter equivalent to 1,200 g.





TABLE FOR THE FERTILIZER DISTRIBUTION – SMB SEEDER – SPEED BOX 4000 / 5000 / 6000

Table 13

Combination	Grams / 50m	Outlet gear of the ratchet shaft							20	Inlet gear of the Speed Box							31	
		Spacing between lines																
		165	170	190	310	340	400	450	500	550	600	650	700	750	800	850	900	950
F-1	319	386	375	335	206	187	159	142	127	116	106	98	91	85	80	75	71	67
F-2	358	434	422	377	231	211	179	159	143	130	119	110	102	96	90	84	80	75
E-1	398	483	468	419	257	234	199	177	159	145	133	123	114	106	100	94	88	84
F-3	410	496	482	431	264	241	205	182	164	149	137	126	117	109	102	96	91	86
E-2	448	543	527	472	289	264	224	199	179	163	149	138	128	119	112	105	100	94
D-1	478	579	562	503	308	281	239	212	191	174	159	147	137	127	119	112	106	101
F-4	478	579	562	503	308	281	239	212	191	174	159	147	137	127	119	112	106	101
E-3	512	621	602	539	330	301	256	228	205	186	171	158	146	137	128	120	114	108
D-2	538	652	632	566	347	316	269	239	215	195	179	165	154	143	134	126	119	113
C-1	557	676	656	587	360	328	279	248	223	203	186	172	159	149	139	131	124	117
F-5	573	695	675	604	370	337	287	255	229	209	191	176	164	153	143	135	127	121
E-4	597	724	703	629	385	351	299	265	269	217	199	184	171	159	149	141	133	126
D-3	614	7745	723	647	396	361	307	273	246	223	205	189	176	164	154	145	137	129
C-2	627	760	738	660	405	369	314	279	251	228	209	193	179	167	157	148	139	132
B-1	637	772	750	671	411	375	319	283	255	232	212	196	182	170	159	150	142	134
A-1	717	869	843	754	462	422	358	319	287	261	239	221	205	191	179	167	159	151
A-2	806	977	949	849	520	474	403	358	323	293	269	248	230	215	202	190	179	170
B-3	819	993	964	862	528	482	410	364	328	298	273	252	234	218	205	193	182	172
C-4	836	1014	984	880	539	492	418	372	334	304	279	257	239	223	209	197	186	176
D-5	860	1043	1012	905	555	506	430	382	344	313	287	265	246	229	215	202	191	181
E-6	896	1086	1054	943	578	527	448	398	358	326	288	276	256	239	224	211	199	289
A-3	922	1117	1084	970	595	542	461	410	369	335	307	284	263	246	230	217	205	194
B-4	956	1158	1124	1006	617	562	478	425	382	348	319	294	273	255	239	225	212	201
C-5	1003	1216	1181	1056	647	590	502	446	401	365	334	309	287	268	251	236	223	211
D-6	1075	1303	1265	1132	694	632	538	478	430	391	358	331	307	287	269	253	239	226
A-4	1075	1303	1265	1132	694	632	538	478	430	391	358	331	307	287	269	253	239	226
B-5	1147	1390	1349	1207	740	675	573	510	459	417	382	353	328	306	287	270	255	241
C-6	1254	1520	1476	1320	809	738	627	557	502	456	418	386	358	334	314	295	279	264
A-5	1290	1564	1518	1358	832	759	645	573	516	469	430	397	369	344	323	304	287	272
B-6	1434	1738	1686	1509	925	843	717	637	573	521	478	441	410	382	358	337	319	302
A-6	1613	1966	1897	1698	1040	949	806	717	645	586	538	496	461	430	403	379	358	340

References: Table elaborated by using 2 inch step spring for fertilizer distribution with density of 1 liter equivalent to 1,200 g.

TABLE FOR THE FERTILIZER DISTRIBUTION– SMB SEEDER – SPEED BOX 4000 / 5000 / 6000

Table 14

Combination	Grams / 50m	Outlet gear of the ratchet shaft							31	Inlet gear of the Speed Box							20	
		Spacing between lines																
		165	170	190	310	340	400	450	500	550	600	650	700	750	800	850	900	950
F-1	765	928	900	806	464	450	383	340	306	278	255	235	219	204	191	180	170	161
F-2	861	1044	1013	906	555	506	431	383	344	313	287	265	246	230	215	203	191	181
E-1	957	1160	1125	1007	617	563	478	425	383	348	319	294	273	255	239	225	213	201
F-3	984	1193	1158	1036	635	579	492	437	394	358	328	303	281	262	246	232	219	207
E-2	1076	1305	1266	1133	694	633	538	478	431	391	359	331	308	287	269	253	239	227
D-1	1148	1392	1351	1208	741	675	574	510	459	417	383	353	328	306	287	270	255	242
F-4	1148	1392	1351	1208	741	675	574	510	459	417	383	353	328	306	287	270	255	242
E-3	1230	1491	1447	1295	794	724	615	547	492	447	410	378	351	328	308	289	273	259
D-2	1292	1565	1519	1359	833	760	646	574	517	470	431	397	369	344	323	304	287	272
C-1	1339	1623	1576	1410	864	788	670	595	536	487	446	412	383	357	335	315	298	282
F-5	1378	1670	1621	1450	889	810	689	612	551	501	459	424	394	367	344	324	306	290
E-4	1435	1739	1688	1511	926	844	718	638	574	522	478	442	410	383	359	338	319	302
D-3	1476	1789	1736	1554	952	868	738	656	590	537	492	454	422	394	369	347	328	311
C-2	1507	1826	1773	1586	972	886	753	670	603	548	502	464	431	402	377	355	335	317
B-1	1531	1855	1801	1611	988	900	765	680	612	557	510	471	437	408	383	360	340	322
A-1	1722	2087	2026	1813	1111	1013	861	765	689	626	574	530	492	459	431	405	383	363
A-2	1937	2348	2279	2039	1250	1140	969	861	778	704	646	596	554	517	484	456	431	408
B-3	1968	2385	2315	2072	1270	1158	984	875	787	716	656	606	562	525	492	463	437	414
C-4	2009	2435	2364	2115	1296	1182	1005	893	801	731	670	618	574	536	502	473	446	423
D-5	2066	2505	2431	2175	1333	1216	1033	918	827	751	689	636	590	551	517	486	459	435
E-6	2153	2609	2532	2266	1389	1266	1076	957	861	783	718	662	615	574	538	506	478	453
A-3	2214	2684	2605	2331	1428	1302	1107	984	886	805	738	681	633	590	554	521	492	466
B-4	2296	2783	2701	2417	1481	1351	1148	1020	918	835	765	706	656	612	574	540	510	483
C-5	2411	2922	2836	2538	1555	1418	1205	1071	964	877	804	742	689	643	603	567	536	508
D-6	2583	3131	3039	2719	1666	1519	1292	1148	1033	939	861	795	738	689	646	608	574	544
A-4	2583	3131	3039	2719	1666	1519	1292	1148	1033	939	861	795	738	689	646	608	574	544
B-5	2755	3340	3241	2900	1778	1621	1378	1225	1102	1002	918	848	787	735	689	648	612	580
C-6	3014	3653	3545	3172	1944	1773	1507	1339	1205	1096	1005	927	861	804	753	709	670	634
A-5	3100	3757	3647	3263	2000	1823	1550	1378	1240	1124	1033	954	886	827	775	729	689	653
B-6	3444	4175	4052	3625	2222	2026	1722	1531	1378	1252	1148	1060	984	918	861	810	765	725
A-6	3875	4696	4558	4078	2500	2279	1937	1722	1550	1409	1292	1192	1107	1033	969	912	861	816

References: Table elaborated by using 2 inch step spring for fertilizer distribution with density of 1 liter equivalent to 1,200 g.





TABLE FOR THE FERTILIZER DISTRIBUTION – SMB SEEDER – SPEED BOX 4000 / 5000 / 6000

Table 15

Combination	Grams / 50m	Outlet gear of the ratchet shaft															20		Inlet gear of the Speed Box															31
		Spacing between lines																																
		165	170	190	310	340	400	450	500	550	600	650	700	750	800	850	900	950																
F-1	100	60	59	52	32	29	25	22	20	18	17	15	14	13	12	12	11	10																
F-2	112	68	66	59	36	33	28	25	22	20	19	17	16	15	14	13	12	12																
E-1	124	75	73	65	40	37	31	28	25	23	21	19	18	17	16	15	14	13																
F-3	128	78	75	67	41	38	32	28	26	23	21	20	18	17	16	15	14	13																
E-2	140	85	82	74	45	41	35	31	28	25	23	22	20	19	17	16	16	15																
D-1	149	90	88	79	48	44	37	33	30	27	25	23	21	20	19	18	17	16																
F-4	149	90	88	79	48	44	37	33	30	27	25	23	21	20	19	18	17	16																
E-3	160	97	94	84	52	47	40	36	32	29	27	25	23	21	20	19	18	17																
D-2	168	102	99	88	54	49	42	37	34	31	28	16	24	22	21	20	19	18																
C-1	174	106	102	92	56	51	44	39	35	32	29	27	25	23	22	20	19	18																
F-5	179	109	105	94	58	53	45	40	36	33	30	28	26	24	22	21	20	19																
E-4	187	113	110	98	60	55	47	41	37	34	31	29	27	25	23	22	21	20																
D-3	192	116	113	101	62	56	48	43	38	35	32	30	27	26	24	23	21	20																
C-2	196	119	115	103	63	58	49	44	39	36	33	30	28	26	24	23	22	21																
B-1	199	121	117	105	64	59	50	44	40	36	33	31	28	27	25	23	22	21																
A-1	224	136	132	118	72	66	56	50	45	41	37	34	32	30	28	26	25	24																
A-2	252	153	148	133	81	74	63	56	50	46	42	39	36	34	31	30	28	27																
B-3	256	155	151	135	83	75	64	57	51	47	43	39	37	34	32	30	28	27																
C-4	261	158	154	138	84	77	65	58	52	48	44	40	37	35	33	31	29	28																
D-5	269	163	158	141	87	79	67	60	54	49	45	41	38	36	34	32	30	28																
E-6	280	170	165	147	90	82	70	62	56	51	47	43	40	37	35	33	31	29																
A-3	288	175	169	152	93	85	72	64	58	52	48	44	41	38	36	34	32	30																
B-4	299	181	176	157	96	88	75	66	60	54	50	46	43	40	37	35	33	31																
C-5	314	190	184	165	101	92	78	70	63	57	52	48	45	42	39	37	35	33																
D-6	336	204	198	177	108	99	84	75	67	61	56	52	48	45	42	40	37	35																
A-4	336	204	198	177	108	99	84	75	67	61	56	52	48	45	42	40	37	35																
B-5	358	217	211	189	116	105	90	80	72	65	60	55	51	48	45	42	40	38																
C-6	392	238	231	206	126	115	98	87	78	71	65	60	56	52	49	46	44	41																
A-5	403	244	237	212	130	119	101	90	81	73	67	62	58	54	50	47	45	42																
B-6	448	271	264	236	145	132	112	100	90	81	75	69	64	60	56	53	50	47																
A-6	504	305	296	265	163	148	126	112	101	92	84	78	72	67	63	59	56	53																

References: Table elaborated by using 5/8 inch step spring for fertilizer distribution with density of 1 liter equivalent to 1,200 g.

TABLE FOR THE FERTILIZER DISTRIBUTION – SMB SEEDER – SPEED BOX 4000 / 5000 / 6000

Table 16

Combination	Grams / 50m	Outlet gear of the ratchet shaft							31	Inlet gear of the Speed Box							20	
		Spacing between lines																
		165	170	190	310	340	400	450	500	550	600	650	700	750	800	850	900	950
F-1	50	290	281	252	154	141	120	106	96	87	80	74	68	64	60	56	53	50
F-2	56	326	317	283	174	158	135	120	108	98	90	83	77	72	67	63	60	57
E-1	62	362	352	315	193	176	149	133	120	109	100	92	85	80	75	70	66	63
F-3	64	373	362	324	198	181	154	137	123	112	103	95	88	82	77	72	68	65
E-2	70	408	396	354	217	198	168	149	135	122	112	103	96	90	84	79	75	71
D-1	75	435	422	378	231	211	179	159	144	130	120	110	103	96	90	84	80	76
F-4	75	435	422	378	231	211	179	159	144	130	120	110	103	96	90	84	80	76
E-3	80	466	452	405	248	226	192	171	154	140	128	118	110	103	96	90	85	81
D-2	84	489	475	425	260	237	202	179	161	147	135	124	115	108	101	95	90	85
C-1	87	507	492	441	270	246	209	186	167	152	140	129	120	112	105	98	93	88
F-5	90	522	506	453	278	253	215	191	172	157	144	132	123	115	108	101	96	91
E-4	93	544	528	472	289	264	224	199	179	163	149	138	128	120	112	106	100	94
D-3	96	559	543	486	298	271	231	205	185	168	154	142	132	123	115	109	103	97
C-2	98	571	554	496	304	277	235	209	188	171	157	145	135	126	118	111	105	99
B-1	100	580	563	504	309	281	239	213	191	174	159	147	137	128	120	113	106	101
A-1	112	652	633	566	347	317	269	239	215	196	179	166	154	144	135	127	120	113
A-2	126	734	712	637	391	356	303	269	242	220	202	186	173	161	151	142	135	127
B-3	128	745	724	647	397	362	308	273	246	224	205	189	176	164	154	145	137	129
C-4	131	761	739	661	405	369	314	279	251	228	209	193	179	167	157	148	140	132
D-5	134	783	760	680	417	380	323	287	258	235	215	199	185	172	161	152	144	136
E-6	140	815	791	708	434	396	336	299	269	245	224	207	192	179	168	158	149	142
A-3	144	839	814	728	446	407	346	308	277	252	231	213	198	185	173	163	154	146
B-4	149	870	844	755	463	422	359	319	287	261	239	221	205	191	179	169	159	151
C-5	157	913	886	793	486	443	377	335	301	274	251	232	215	201	188	177	167	159
D-6	168	978	950	850	521	475	404	359	323	294	269	248	231	215	202	190	179	170
A-4	168	978	950	850	521	475	404	359	323	294	269	248	231	215	202	190	179	170
B-5	179	1044	1013	906	555	506	431	383	344	313	287	265	246	230	215	203	191	181
C-6	196	1141	1108	991	608	554	471	419	377	342	314	290	269	251	235	222	209	198
A-5	202	1174	1140	1020	625	570	484	431	387	352	323	298	277	258	242	228	215	204
B-6	224	1305	1266	1133	694	633	538	478	431	391	359	331	308	287	269	253	239	227
A-6	252	1468	1424	1275	781	712	605	538	484	440	404	373	346	323	303	285	269	255

References: Table elaborated by using 5/8 inch step spring for fertilizer distribution with density of 1 liter equivalent to 1,200 g.





TABLE FOR THE FERTILIZER DISTRIBUTION– SMB SEEDER – SPEED BOX 4000 / 5000 / 6000

Table 17

Combination	Grams / 50m	Outlet gear of the ratchet shaft															20		Inlet gear of the Speed Box															31
		Spacing between lines																																
		165	170	190	310	340	400	450	500	550	600	650	700	750	800	850	900	950																
F-1	60	72	70	63	39	35	30	27	24	22	20	18	17	16	15	14	13	13																
F-2	67	82	79	71	43	40	34	30	27	24	22	21	19	18	17	16	15	14																
E-1	75	91	88	79	48	44	37	33	30	27	25	23	21	20	19	18	17	16																
F-3	77	93	90	81	50	45	38	34	31	28	26	24	22	20	19	18	17	16																
E-2	84	102	99	88	54	49	42	37	34	31	28	26	24	22	21	220	19	18																
D-1	90	109	105	94	58	53	45	40	36	33	30	28	26	24	22	21	20	19																
F-4	90	109	105	94	58	53	45	40	36	33	30	28	26	24	22	21	20	19																
E-3	96	116	113	101	62	57	48	43	38	35	32	30	27	26	24	23	21	20																
D-2	101	122	119	106	65	59	50	45	40	37	34	31	29	27	25	24	22	21																
C-1	105	127	123	110	67	62	52	46	42	38	35	32	30	28	26	25	23	22																
F-5	108	130	127	113	69	63	54	48	43	39	36	33	31	29	27	25	24	23																
E-4	112	136	132	118	72	66	56	50	45	41	37	34	32	30	28	26	25	24																
D-3	115	140	136	121	74	68	58	51	46	42	38	35	33	31	29	27	26	24																
C-2	118	143	138	124	76	69	59	52	47	43	39	36	34	31	29	28	26	25																
B-1	120	145	141	126	77	70	60	53	48	43	40	37	34	32	30	28	27	25																
A-1	134	163	158	142	87	79	67	60	54	49	45	41	38	36	34	32	30	28																
A-2	151	183	178	159	98	89	76	67	61	55	50	47	43	40	38	36	34	32																
B-3	154	186	181	162	99	90	77	68	61	56	51	47	44	41	38	36	34	32																
C-4	157	190	185	165	101	92	78	70	63	57	52	48	45	42	39	37	35	33																
D-5	161	196	190	170	104	95	81	72	65	59	54	50	46	43	40	38	36	34																
E-6	168	204	198	177	108	99	84	75	67	61	56	52	48	45	42	40	37	35																
A-3	173	210	203	182	112	102	86	77	69	63	58	53	49	46	43	41	38	36																
B-4	179	217	211	189	116	105	90	80	72	65	60	55	51	48	45	42	40	38																
C-5	188	228	221	198	121	111	94	84	75	68	63	58	54	50	47	44	42	40																
D-6	202	245	237	212	130	119	101	90	81	73	67	62	58	54	50	47	45	42																
A-4	202	245	237	212	130	119	101	90	81	73	67	62	58	54	50	47	45	42																
B-5	215	261	253	226	139	127	108	96	86	78	72	66	61	57	54	51	48	45																
C-6	235	285	277	248	152	38	118	105	94	86	78	72	67	63	59	55	52	50																
A-5	242	293	285	255	156	142	121	108	97	88	81	74	69	65	61	57	54	51																
B-6	269	326	316	283	174	158	134	120	108	98	90	83	77	72	67	63	60	57																
A-6	303	367	356	318	195	178	151	134	121	110	101	93	86	81	76	71	67	64																

References: Table elaborated by using 3/4 inch step spring for fertilizer distribution with density of 1 liter equivalent to 1,200 g.

TABLE FOR THE FERTILIZER DISTRIBUTION– SMB SEEDER – SPEED BOX 4000 / 5000 / 6000

Table 18

Combination	Grams / 50m	Outlet gear of the ratchet shaft							31	Inlet gear of the Speed Box							20	
		Spacing between lines																
		165	170	190	310	340	400	450	500	550	600	650	700	750	800	850	900	950
F-1	144	174	169	151	93	84	72	64	57	52	48	44	41	38	36	34	32	30
F-2	162	196	190	170	104	95	81	72	65	59	54	50	46	43	40	38	36	34
E-1	179	218	211	189	116	106	90	80	72	65	60	55	51	48	45	42	40	38
F-3	185	224	217	194	119	109	92	82	74	67	62	57	53	49	46	43	41	39
E-2	202	245	238	213	130	119	101	90	81	73	67	62	58	54	50	48	45	43
D-1	215	261	253	227	139	127	108	96	86	78	72	66	62	57	54	51	48	45
F-4	215	261	253	227	139	127	108	96	86	78	72	66	62	57	54	51	48	45
E-3	231	280	271	243	149	136	115	103	92	84	77	71	66	62	58	54	51	49
D-2	242	294	285	255	156	143	121	108	97	88	81	75	69	65	61	57	54	51
C-1	251	305	296	265	163	148	126	112	101	91	84	77	72	67	63	59	56	53
F-5	258	313	304	272	167	152	129	115	103	94	86	80	74	69	65	61	57	54
E-4	269	326	317	283	174	158	135	120	108	98	80	83	77	72	67	63	60	57
D-3	277	336	326	291	179	163	138	123	111	101	92	85	79	74	69	65	62	58
C-2	283	343	333	298	182	166	141	126	113	103	94	87	81	75	71	67	63	60
B-1	287	348	338	302	185	169	144	128	115	104	96	88	82	77	72	68	64	60
A-1	323	392	380	340	208	190	162	144	129	117	108	99	92	86	81	76	72	68
A-2	363	441	428	383	234	214	182	162	145	132	121	112	104	97	91	86	81	77
B-3	369	448	434	389	238	217	185	164	148	134	123	114	105	98	92	87	82	78
C-4	377	457	443	397	243	222	188	168	151	137	126	116	108	101	94	89	84	79
D-5	388	470	456	408	250	228	194	172	155	141	129	119	111	103	97	91	86	82
E-6	404	490	475	425	261	238	202	179	162	147	135	124	115	108	101	95	90	85
A-3	415	503	489	437	268	244	208	185	166	151	138	128	119	111	104	98	92	87
B-4	431	522	507	453	278	253	215	191	172	157	144	133	123	115	108	101	96	91
C-5	452	548	532	476	292	266	226	201	181	164	151	139	129	121	113	106	101	95
D-6	485	587	570	510	313	285	242	215	194	176	162	149	138	129	121	114	108	102
A-4	480	587	570	510	313	285	242	215	194	176	162	149	138	129	121	114	108	102
B-5	517	627	608	544	333	304	258	230	207	188	172	159	148	138	129	122	115	109
C-6	565	685	665	595	365	333	283	251	226	206	188	174	162	151	141	133	123	119
A-5	582	705	684	612	375	342	291	258	233	211	194	179	166	155	145	137	129	122
B-6	646	783	760	680	417	380	323	287	258	235	215	199	185	172	162	152	144	136
A-6	727	881	855	765	469	428	363	323	291	264	242	224	208	194	182	171	162	153

References: Table elaborated by using 3/4 inch step spring for fertilizer distribution with density of 1 liter equivalent to 1,200 g.



12 - PRACTICAL CALCULATION FOR FERTILIZER AND SEED DISTRIBUTION

- 1- Determine the spacing between lines and the amount of fertilizer to be distributed by Bushel (Aa) or Hectare (Ha).
- 2- **Example:** Seeder with spacing of 450 mm, to distribute 500 Kg of fertilizer per hectare, use the formula below:

Formula:

$$X = \frac{E \times Q \times D}{A}$$

$$X = \frac{450 \times 500 \times 50}{10.000}$$

$$X = 22.50 \times 50 = 1125$$

$$X = 1125 \text{ grams in 50 meters per line}$$

where:

E = spacing between lines (mm)

Q = Amount of fertilizer to be distributed [kg]

A = Area to be fertilized [m²]

D = distance of 50 meters (test)

X = grams of fertilizer in 50 meters

PRACTICAL TEST FOR MEASURING THE AMOUNT OF FERTILIZER AND SEED DISTRIBUTION

- 3- To more precise distribution of both seeds and fertilizer, perform the test of the amount to be distributed on the planting site because for each land, there is a specific condition.
- 4- Check and keep the tires in adequate calibration with 60 lb / in² each.
- 5- Find the test distance in the table, we have selected 50 linear meters.
- 6- Fill the seed tanks at least halfway. Run some meters outside the testing area, so that the seeds and fertilizer fill the dosimeters.
- 7- Seal the seed spout outlets and place containers for collection in the fertilizer outputs. Move the tractor in the testing area, always at the same speed that will be used in planting.

- 8- After running the delimited space (fertilizer table) in the column (grams per line in 50 meters), remove the sealing of the seed spout and collect them for counting and weighing of the fertilizer collected. If it is necessary to increase or decrease the amount of fertilizer and seed, proceed through the Speed Box.

ADJUSTMENT OF THE LINE MARKER DISC

- 9- The line marker disc (1) has angle adjustment to facilitate the work of ground markings. For this adjustment, loosen the nut (2) and rotate the disc to the desired position. Figure 38.

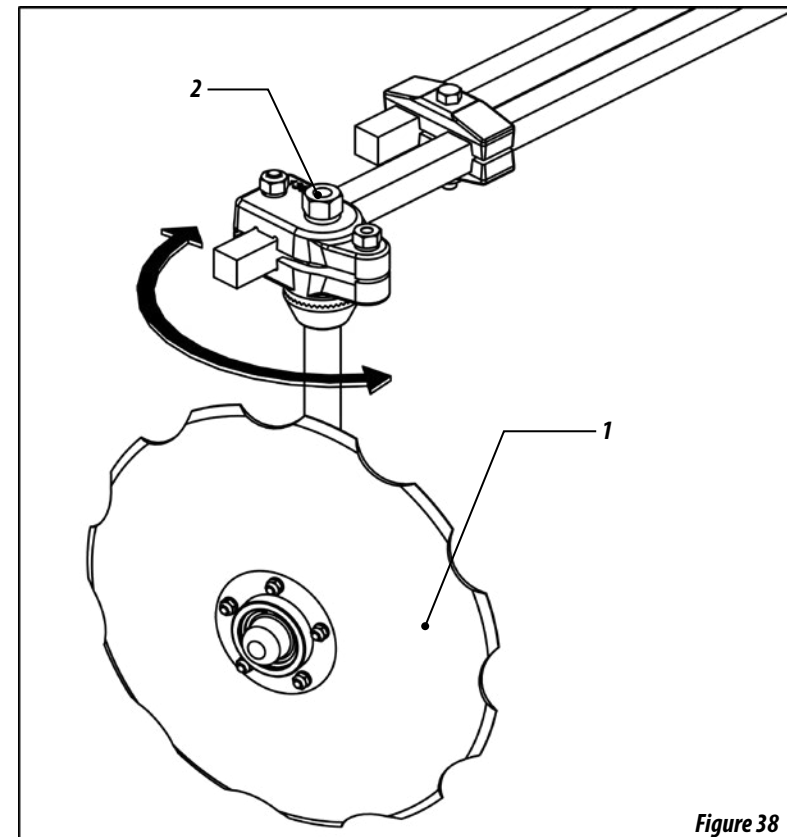

Figure 38

13 - DEPTH ADJUSTMENT

FURROW OPENING AND FERTILIZER POSITION ON THE GROUND SEEDER SYSTEM – LARGE SEEDS

- 1- The furrow opening in the soil so that the fertilizer is deposited is done by or double discs or furrowers in the following systems:
 - Side fertilization and below the seed.
 - Fertilization on the same line and below the seed.

FURROWER POSITION

- 2- The furrower has two working positions. Remove the screw (1), position the furrower (2) through the bottom hole and replace the screw (1).
- 3- If it is necessary to adjust the height of the fertilizer depth, loosen the screws (3) from the furrower (2) moving the spout (4) as
- 4- Adjust the spring pressure (5) of the furrower by removing the lock and washer (6) positioning the pin (7) in the hole - detail "a". Figure 39.

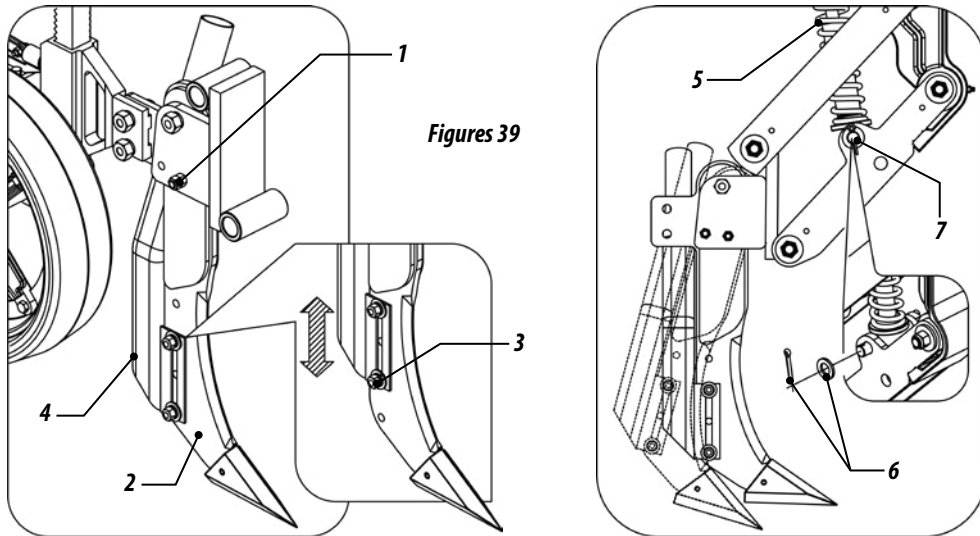

Figures 39

ADJUSTMENT OF THE CUTTING DISC DEPTH

- 5- To adjust the cutting disc depth (1), loosen the screws (2) and move the shaft (3) for the desired setting. Then, retighten the screws (2). Figures 39.
- 6- Adjust the spring pressure (4) of the cutting disc by removing the lock and washer (5) positioning the pin (6) in the hole - detail "b". Figure 41.

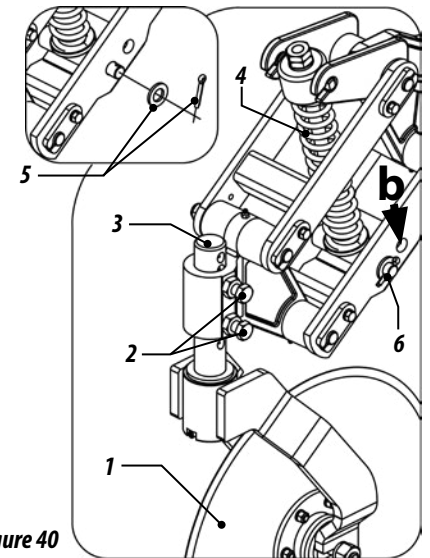

Figure 40

ADJUSTMENT OF THE DOUBLE DISC CLEANERS

- 7- The double discs have cleaners (1) that are flexible and adjustable through screws (2), to remove the soil adhering to them.

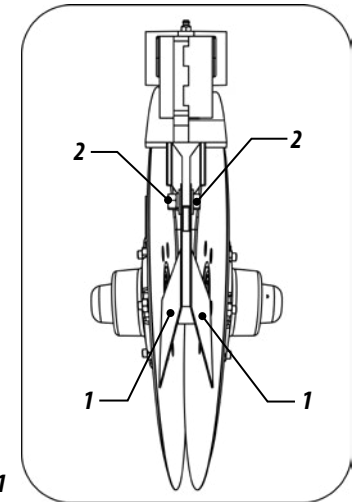

Figure 41

OSCILLATING DEPTH LIMITING WHEEL DEPTH AND "V" COMPACTION WHEEL

- 8- The seed depth is individually made by the depth limiting wheels. For this setting, pull the lock pin (1) through the handle (2) and move the wheel (3) by pushing down or pulling up, leaving it to the desired setting. Make the same setting on all wheels. Then, lock the handle.

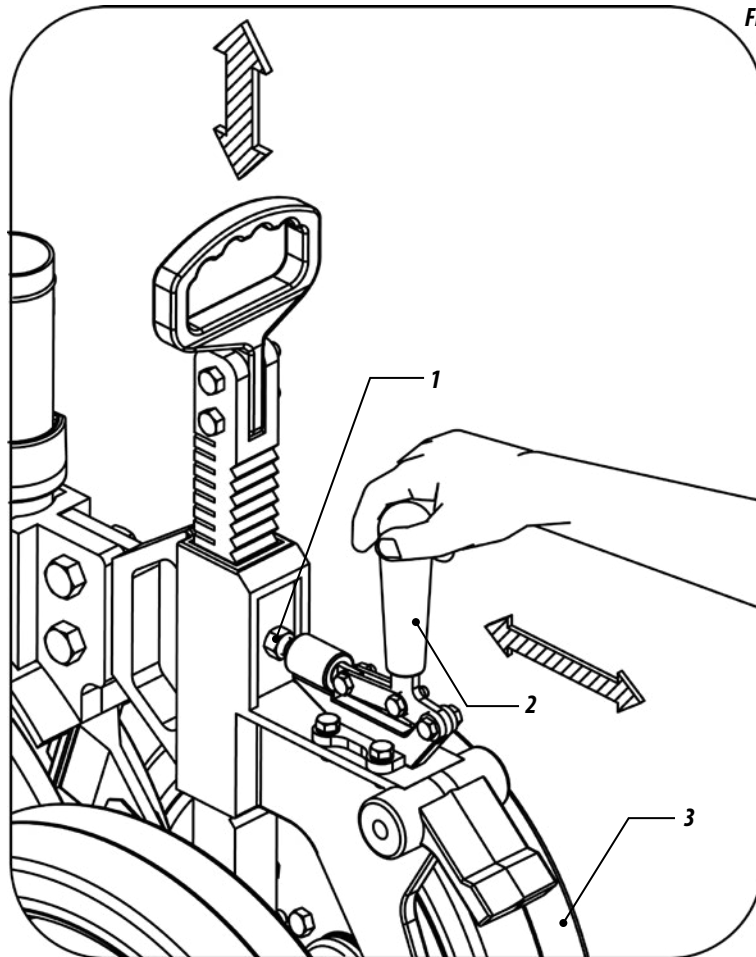
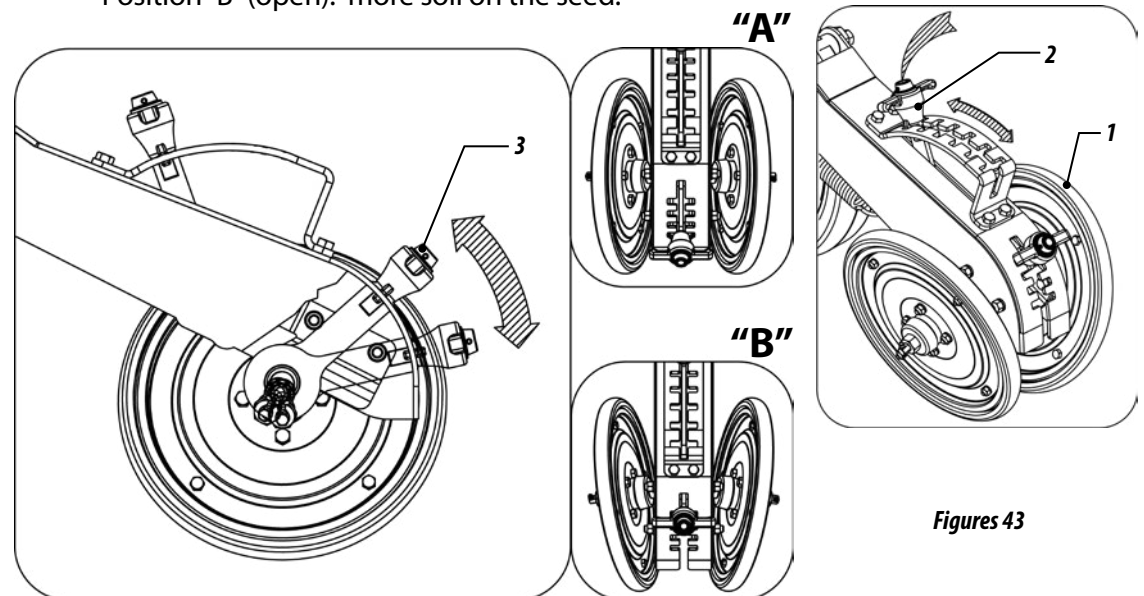

Figure 42

ADJUSTING THE "V" COMPACTION WHEEL

- 9- The "V" compaction wheels are intended to press the furrow laterally, causing the soil to be immediately placed on the seed, avoiding excess compression, facilitating germination and plant development.
- 10- The wheel pressure (1) is made through the lever (2), which when shifted back, give more pressure on the wheels.
- 11- The wheels can be tilted by the lever (3). For this, pull it back and move it, observing the wheel position and its use:
- Position "A" (closed): less soil on the seed.
 - Position "B" (open): more soil on the seed.



Figures 43

ⓘ IMPORTANT

Make the same adjustment for all compaction wheels and consider the type of soil, seed and planting depth in order not to affect the free emergence of plants.

- 12- The wheels were developed with eccentric bushings (1), and for horizontal displacement, loosen the screws (2) rotate the bushing (1), with a key to performance and alignment of the wheels with the furrow, placing a greater or lesser amount of soil laterally to the seed. Figure 44.
- 13- This adjustment should be made according to the type of soil and culture.

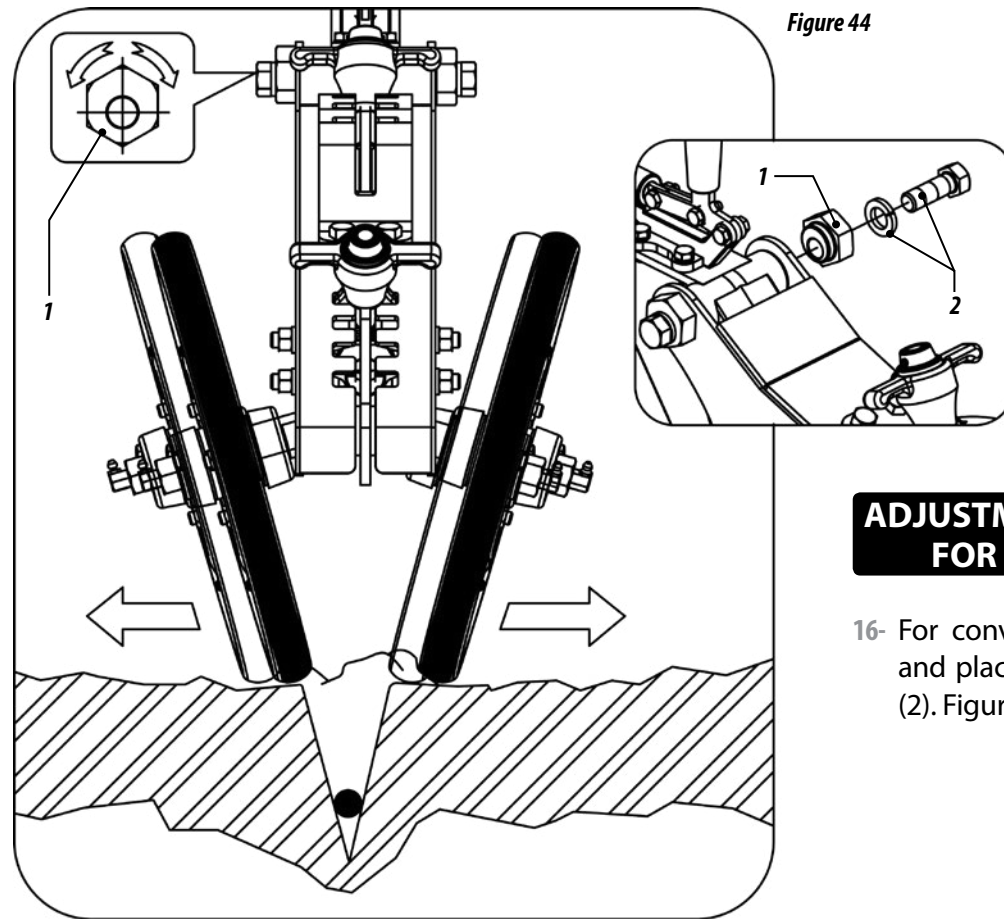

ADJUSTMENT OF THE PRESSURE SPRING FOR CONVENTIONAL PLANTING

- 16- For conventional planting, release the pressure and place the limiting rings (1) to the piston rod (2). Figure 46.

ADJUSTING THE "V" COMPACTION WHEEL

- 14- The depth adjustment of the fertilizer is made through the pressure of springs on the planting lines. This adjustment is done through the nut, as follows;
- 15- To increase the spring pressure, tighten the nut (1) to the rod (2), and vice versa.

IMPORTANT

All lines must have the same adjustment.

Figure 45

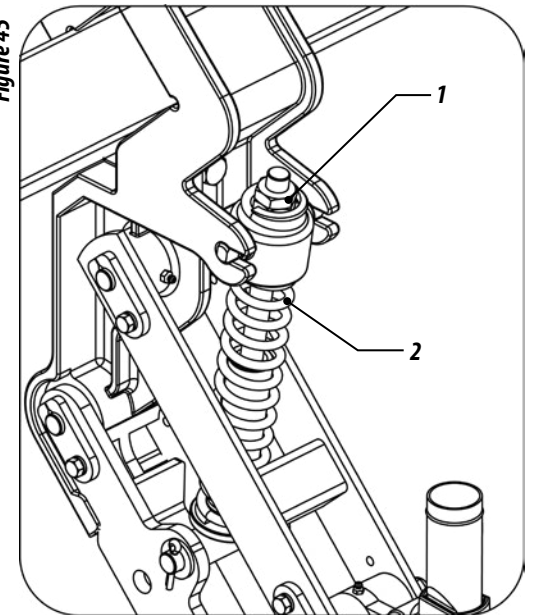
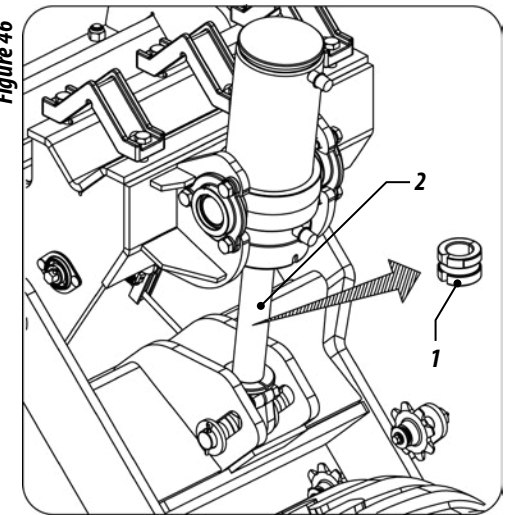

Figure 46



14 - OPERATIONS

- 1- After the first day of work with the seeder, retighten all screws and nuts. Check the conditions of pins, cotter and locks.
- 2- Keep the tires with the same pressure (60 lbs / in²) to prevent wear and maintain uniformity of planting.
- 3- Observe the lubrication intervals.
- 4- When filling the tanks, check for objects inside them such as nuts, screws, etc. Always use seeds and fertilizer free of impurities.
- 5- Always observe the correct functioning of seed and fertilizer distribution mechanisms and also the settings established at the beginning of operation.
- 6- Keep the seeder always leveled; the tractor drawbar must remain fixed and the working speed should remain constant.
- 7- Always check the seed and fertilizer depth, as well as the pressure of compaction wheel.
- 8- Observe the position of the fertilizer in relation to the seed in the soil.
- 9- The line markers must be adjusted according to the spacing of the crop to be planted.

15 - MAINTENANCE

TIRE PRESSURE

- 1- Tires should always be properly calibrated to avoid premature wear due to excess or lack of pressure and ensuring accuracy in the distribution.
- 2- The tire pressure must be 60 lb / in² each.

LUBRICATION

- 3- Lubrication is essential for good performance and durability of the seeder moving parts, helping to reduce maintenance costs.
- 4- Before starting operation, lubricate all grease fittings carefully always observing lubrication intervals in the following pages. Make sure the lubricant is of good quality; avoid using products contaminated by water, dirt and other agents.

TABLE OF GREASE AND EQUIVALENT

MANUFACTURER	TYPE OF RECOMMENDED GREASE
Petrobrás	Lubrax GMA 2
Atlantic	Litholine MP 2
Ipiranga	Super Graxa Ipiranga Ipiranga Super Graxa 2 Ipiflex 2
Castrol	LM 2
Mobil	Mobilgrease MP 77
Texaco	Marfak 2 Agrotex 2
Shell	Retinax A Alvania EP 2
Esso	Multipurpose grease H
Bardahl	Maxlub APG 2 EP

Table 18



If there are other lubricants and / or equivalent greases not listed in this table, refer to the manufacturer's technical handbook.

Excessive pressure

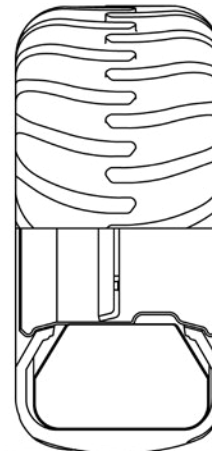

Lack of pressure

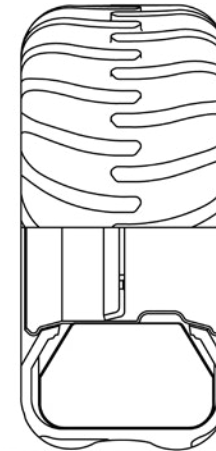

Correct pressure

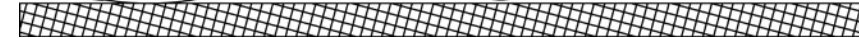
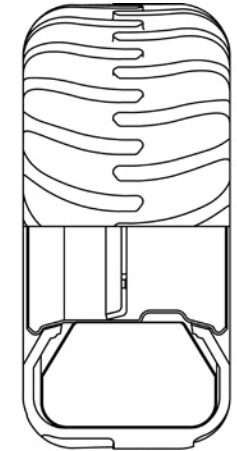

Figure 47

LUBRICATION

- 5- The centralized lubrication system (1) makes maintenance faster and easier, allowing lubricating all lateral and central points of the machine.
- 6- Before starting the lubrication, clean all grease fittings with a soft, lint-free cloth and replace the damaged ones.
- 7- Lubricate all grease fittings every 10 hours.

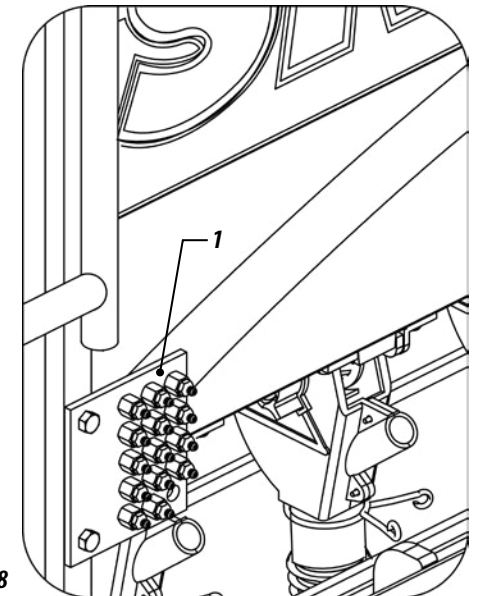
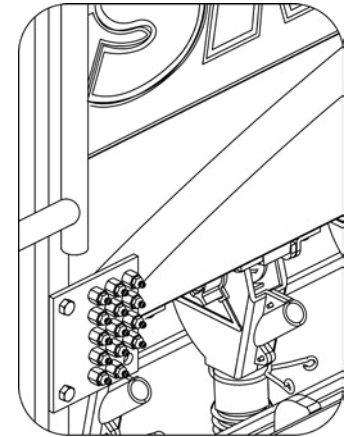
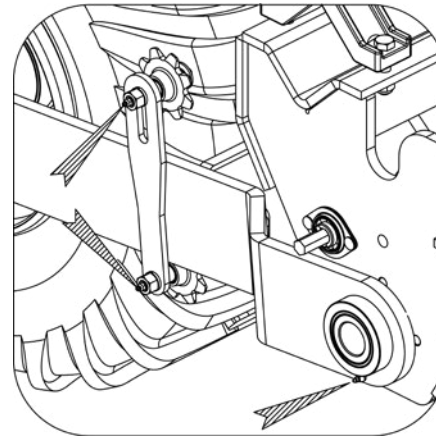
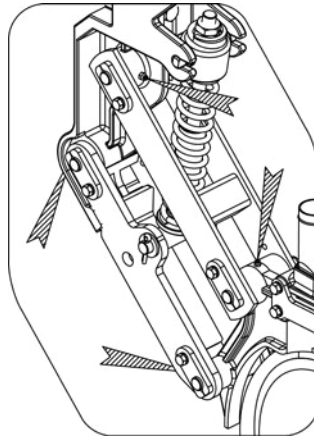
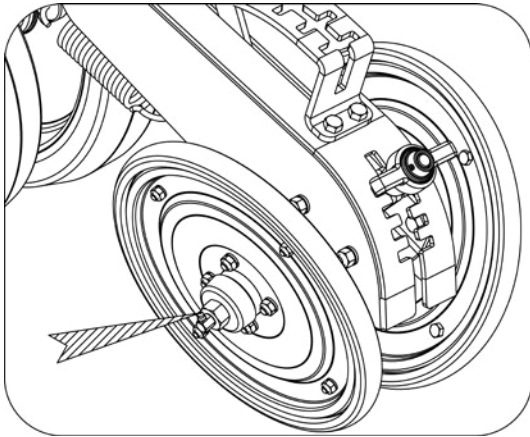
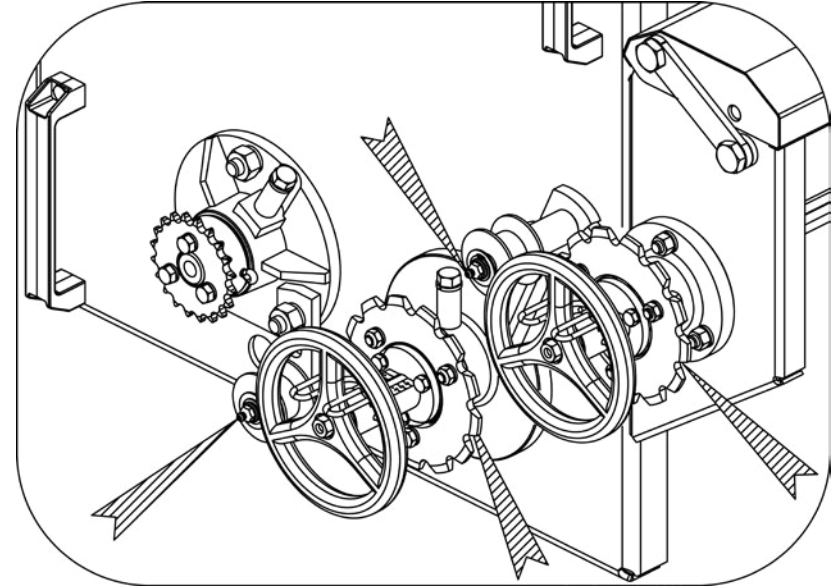
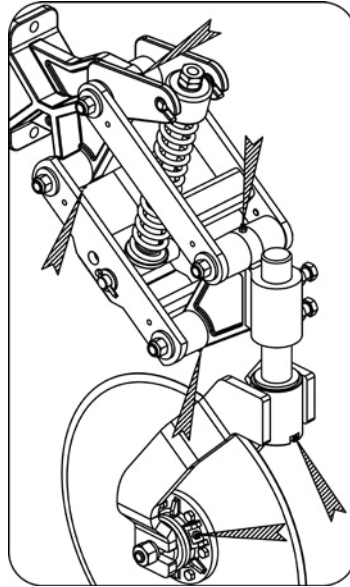
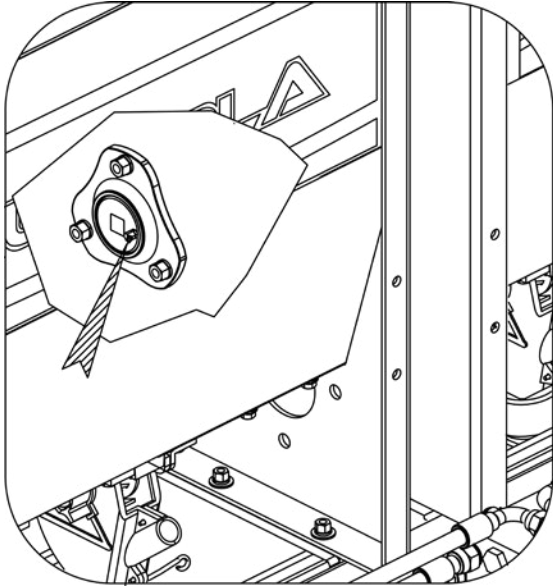

Figure 48

LUBRICATION POINTS

Figures 49

1- Lubricate at every 10 hours of work.



2- Lubricate at every 10 hours of work.

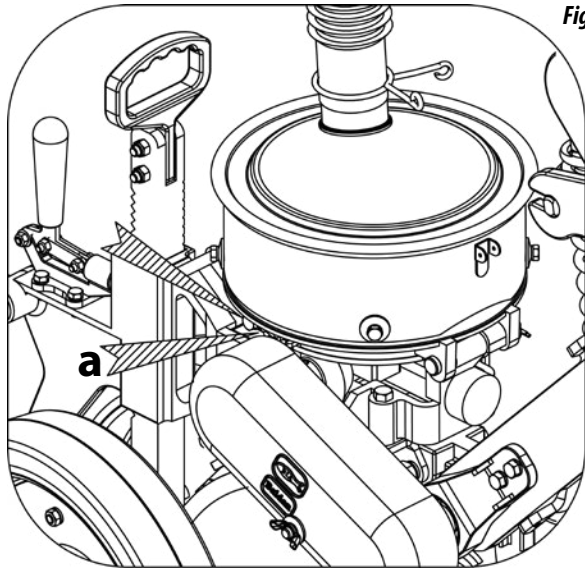

Figure 50

 **IMPORTANT**

Do not put too much grease in the seed distribution crown gear "a", this could clog the seed conductor.

4- Lubricate at every 60 hours of work.

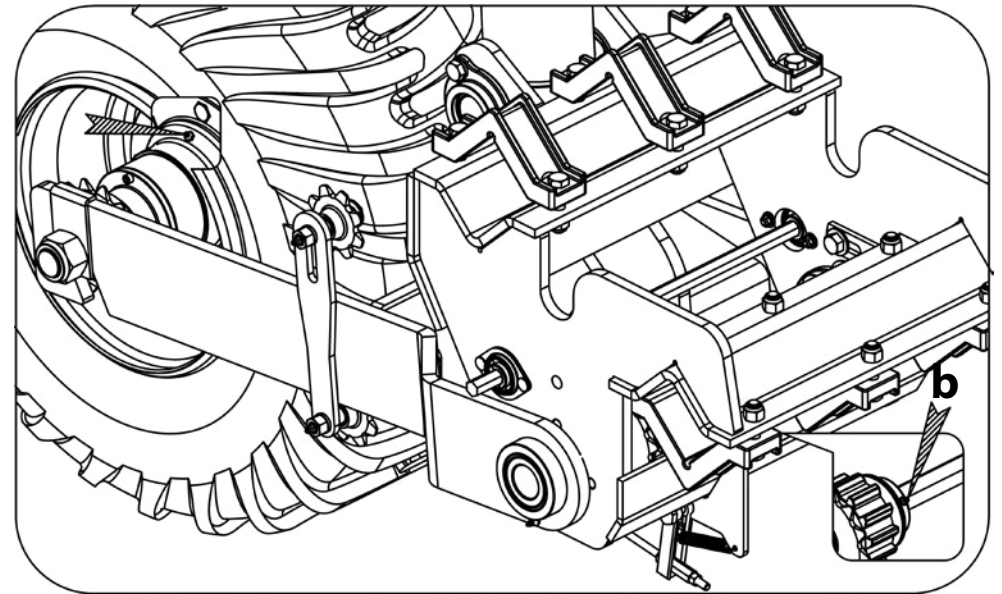
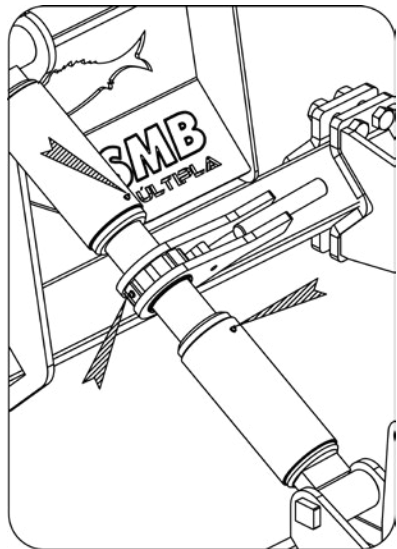

Figure 52

 **IMPORTANT**

Do not put too much grease in the ratchet, respect the interval of 60 hours for relubrication detail "b".

3- Lubricate at every 30 hours of work.



Figures 51

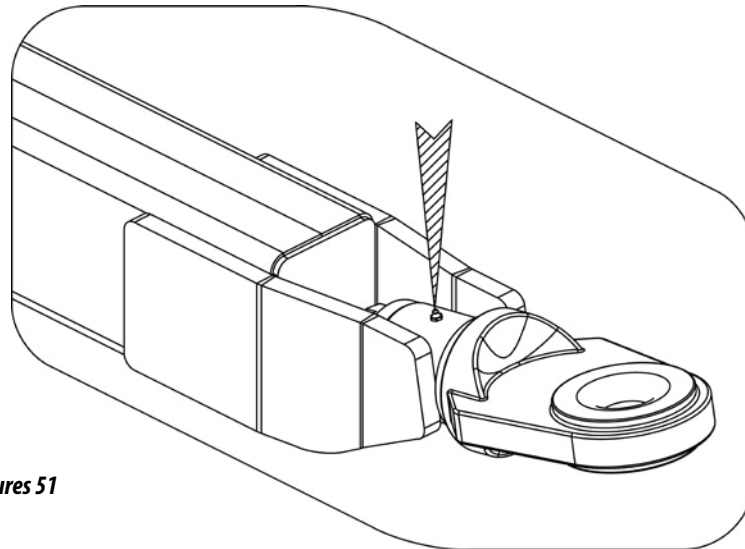

5- Lubricate at every 200 hours of work.

- Periodically lubricate the hubs of double discs and depth wheels approximately every 200 hours and at the end of each harvest season as follows:

- Remove the seal ring (1) the hub (2).
- Examine the bearing, if any clearances, fit through the castle nut (3).
- Put some new grease in the cap (4).
- Replace the cap on the hub and fix it with the seal ring (1). Figure 53.

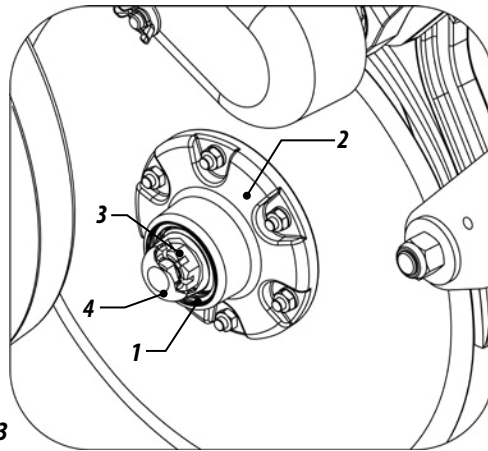

Figure 53

OSCILLATING STRETCHER

6- The Stretcher (5) is equipped with torsion spring for more flexibility. If more pressure on the stretcher is necessary, turn the rosette (6) coupling the spring (7) in the other tooth of the rosette.

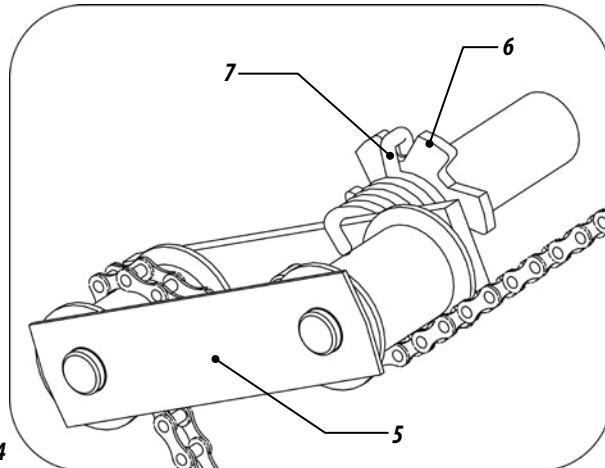

Figure 54

16 - OIL REPLACEMENT (SPEED BOX)

- 1- Perform the oil exchange of the Speed Box (1) after the first 30 hours, then at every 1500 hours.
- 2- The tank capacity is 1.8 liters. It is recommended to use of mineral oil ISO VG 150 at 40°C.
- 3- To make the oil depletion, remove the plug (2) located at the bottom of the gearbox.
- 4- For the oil replacement, remove the vent (3), replace the plug (2) place the oil and check through the viewfinder (4) if the desired level is reached.
- 5- Check the oil level daily through the viewfinder (4).



Only use oil recommended by the manufacturer.



When replacing the oil, observe the initial positions of the vent and depletion plugs, so that they can be reassembled correctly. Make sure it is well sealed and that there are no leaks.

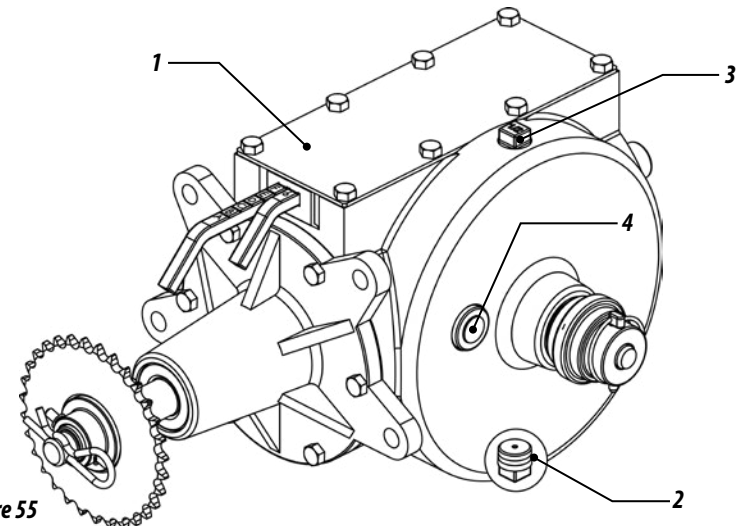

Figure 55

PROBLEMS	PROBABLE CAUSES	SOLUTIONS
During planting, fertilizer leaks through the safety outputs.	Hoses are clogged or there are pieces of plastic in the spiral hoses that conduct the fertilizer.	Unclog the hoses or remove the upper channel that gives access to coil, rotate the shaft to the opposite side until the foreign body is removed.
Hub shaft of the fertilizer tank does not turn.	Spiral blocked with wet fertilizer or excess fertilizer in closed line.	Unclog the coils, check if there is loose gutter and if the fertilizer is coming in through their sides.
Unable to make the coupling of quick couplers of hoses on the tractor.	The hoses were disengaged with pressure or it is bearing the weight of the seeder in the hydraulic system.	Drain hoses or place the seeder on the support feet and finally release the pressure.
A planting line shows depth different from the other.	Different settings of pressure on the depth limiting wheels or in the line springs.	Set all the depth wheels and the pressure of the springs evenly.
The groove is opening up too much during planting.	Soil that sticks to the discs or excessive working speed.	Decrease the work speed.
Pistons stop operating, raise the seeder and do not go down or vice versa.	Different quick coupler, ball-type male and needle-type female or vice - versa.	Replace the quick coupling, placing both of the same type.
Strange noise when operating or riding with the seeder loaded.	Loose wheels or hub with clearance.	Retighten the nuts of the wheel. Adjust the bearings of the wheel hub.
The seeder leaves the planting line, sometimes on one side, sometimes on the other.	Tractor drawbar loose.	Use the pin that came with the seeder. Attach the tractor drawbar in the center hole.
Broken seeds	Too high planting speed.	Decrease the work speed.
	Inadequate disc thickness.	Use adequate disc (thickness and diameter of the holes).
	Disc improperly assembled. The seed sieve is not suitable for the disc selected	Place the disc properly (see the phrase: THIS SIDE DOWN).
	Wet seed	Use dry seeds

Table 19

17 - CLEANING

FERTILIZER SYSTEM - METAL AND STAINLESS STEEL TANK

- After planting, do not let fertilizer in tanks, do their cleaning as follows;

- 1- Remove the transmission protective cover (1), loosen nuts and washers (2) from the hub (3), only from the outside of the seeder, pull the hub with the full shaft (3), rotating it for easy removal. Check the PVC channels (4) that are arranged in the bottom of the tank, if they present wear, replace them.
- 2- Make the cleaning in the tanks and also on the shafts and then wash them with running water. Reassemble the shafts observing the correct assemblage of the channel set, since the fertilizer outlet holes of both the channel and the spout must match as in detail "a" of Figure 56.



When assembling the shaft, it must turn freely, even with a full tank.

SEED SYSTEM

- 3- At the end of each work day, we recommend removing all the seeds from the distribution box and clean it. To clean the seed tank, proceed as follows:
- 4- Remove the seed spouts (5);
- 5- Fully open the cover (6) of the seed distribution box;
- 6- Unlock the lever (7) of the regulator (8) leaving them loose;
- 7- Open wide the steering wheel (9) of the seed tank until the rotor output is fully open;
- 8- Turn the seed shaft (10) with a wrench to drop all seeds;
- 9- Do the cleaning of the seed tank;
- 10- After cleaning, reassemble the tank.



If the seeder is stored, also remove the hoses that conduct fertilizer and seeds, wash them with mild soap and water and replace them.

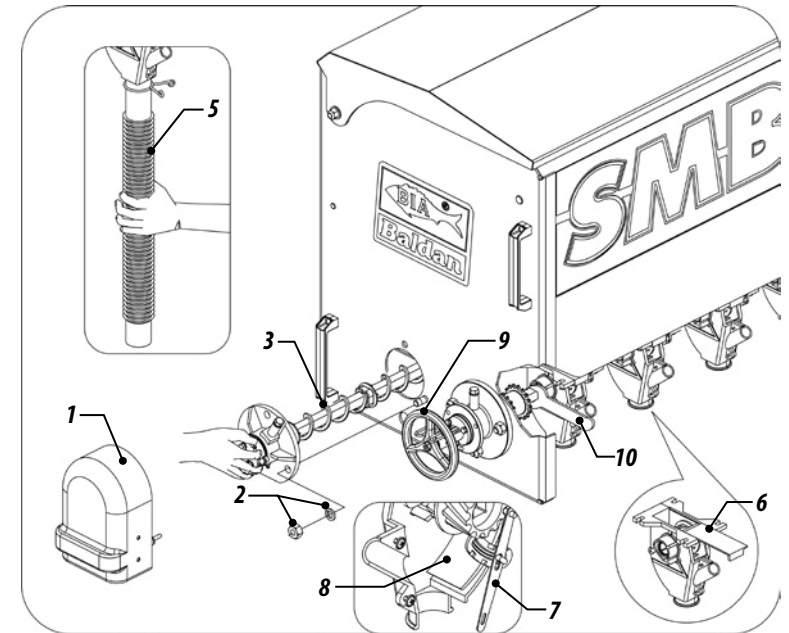

Figures 56

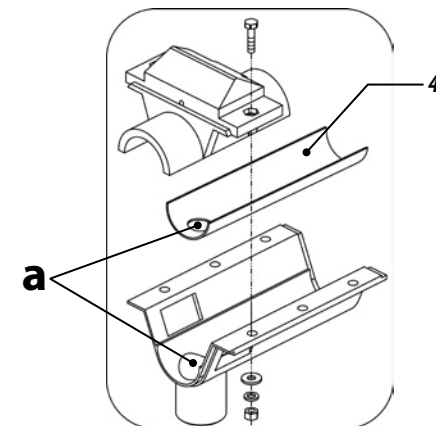

SEED SYSTEM - UNIVERSAL

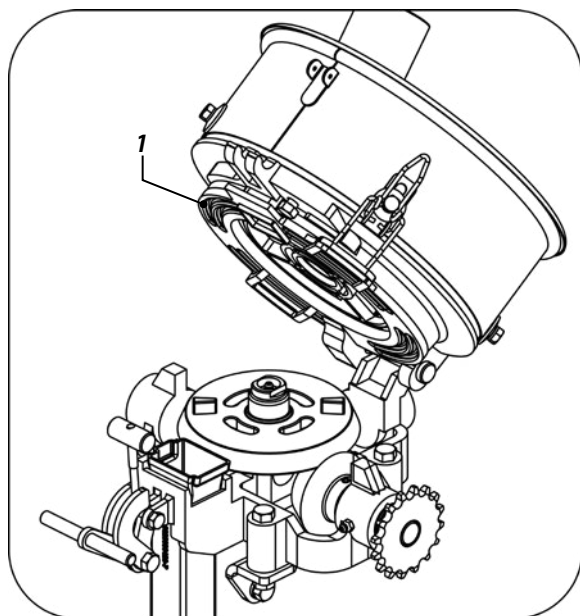

Figures 57

- 1- At the end of each working day, we recommend emptying the seed tanks, remove the distribution discs (1) and clean them, observe the operation of the seed dosimeter (2), by verifying the spring pressure of the triggers, thus ensuring maximum precision in seed distribution.
- 2- When storing the seeder, make a general clean and wash it. Make sure the paint did not wear off, if so, give an overall coat, pass protective oil and completely lubricate the seeder.



When using the products for seed treatment (inoculants, graphite, etc.), it is necessary to clear the system twice a day.

TABLE OF WORKING SPEEDS RECOMMENDED FOR MAIN CROPS

CULTURE	SPEED
CORN	4.5 to 6.0 km / h
SOY	6.0 to 7.0 km / h
BEAN	5.5 to 6.5 km / h
SORGHUM	6.0 to 7.0 km / h



Use graphite or industry talc during the planting operation, thus avoiding friction of the seed with the system (disc).

Table 20



Do not use chemical cleaners to wash the seeder, as this may damage its paintwork.

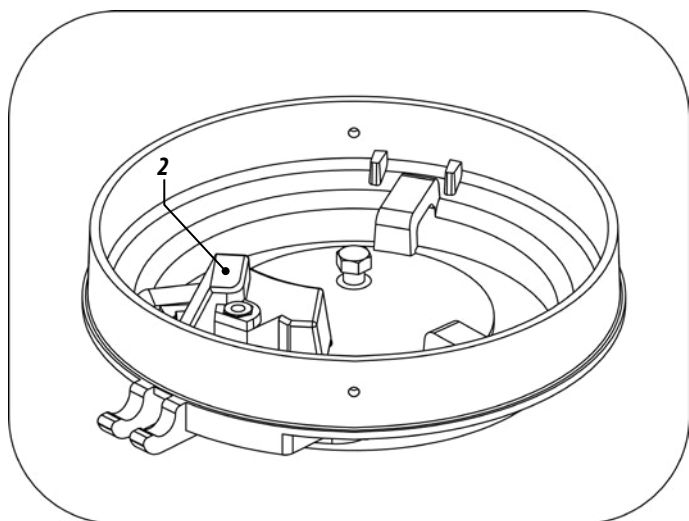

GENERAL CLEANING

- 3- Remove the transmission chains, and keep them immersed in oil until the next use.
- 4- Lubricate the machine completely. Check all moving parts, if they show signs of wear and clearances, make the necessary adjustment or replacement of parts, leaving the machine ready for the next use. Use only original Baldan parts.
- 5- After all the maintenance procedures, store your seeder in a covered and dry place, properly supported. Avoid the discs to be in direct contact with the ground.
- 6- We recommend washing the machine at the beginning of the new planting.

18 - OPTIONAL EQUIPMENT

DEPTH LIMITING WHEEL WITH ANGULAR ADJUSTMENT

- 1- The control of the seed depth is individually performed by convex compacting wheels (1), unlocking the handle (2) and moving the lever (3).
- 2- The wheels are fixed on a shaft with the ends in degree (4), especially designed to enable compression, depth control and bury the seed. For these adjustments, release the latch (5) and rotate the shaft (4), watching the wheel movements:

- **Parallel Inclined:** To compress the soil without accumulating land on the seed (dry land).

- **Closed Inclined:** To remove land, preventing more land to fall on the seed.

- 3- The compacting wheels are regulated by the handle (5). For higher pressure, move it (6) according to the desired pressure.

Figure 58

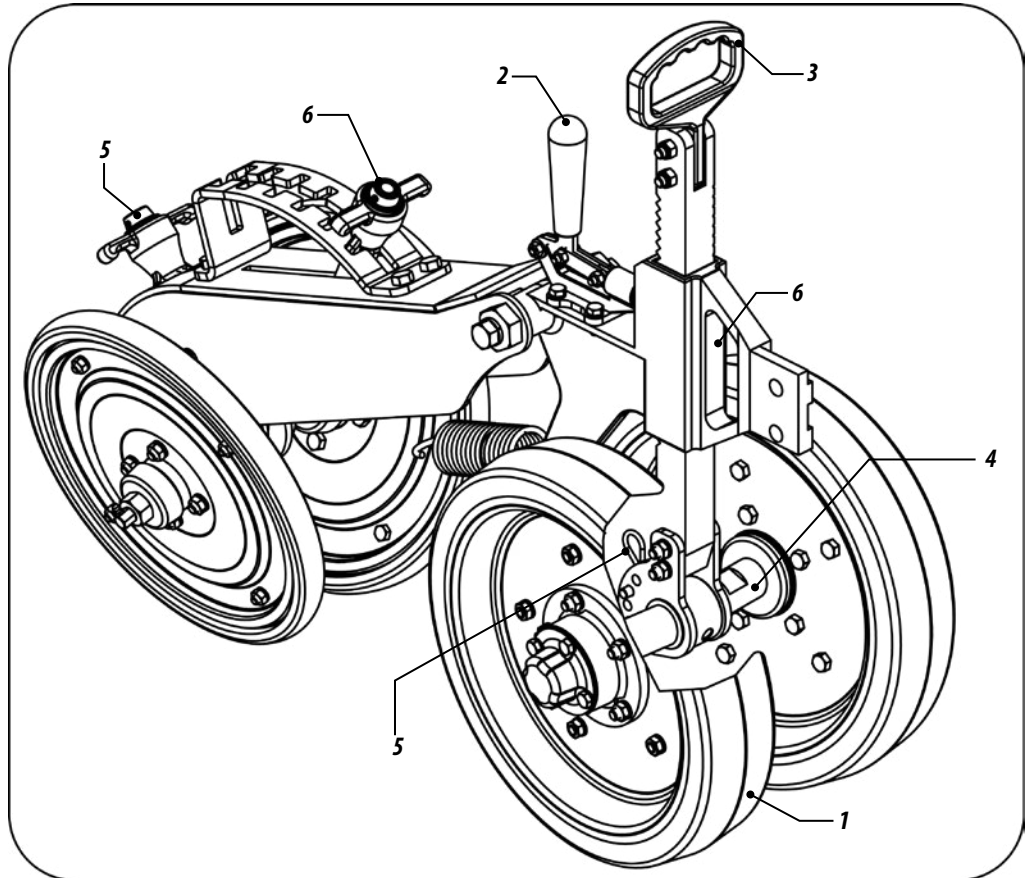

05 cart of the cutting disc

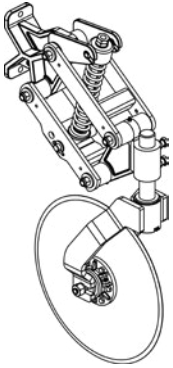

06 cart with fertilizer furrower

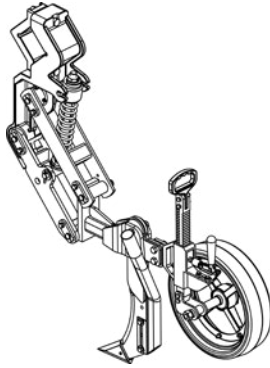

08 cart of the "V" wheel and depth control wheel

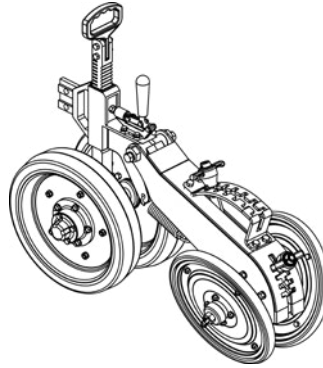

09 eccentric wheel for planter and seeder

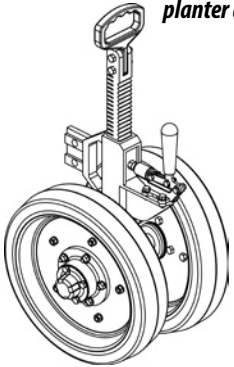

10 rear eccentric depth control wheel

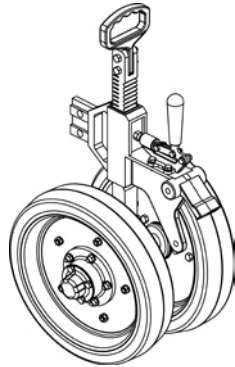

07 cart of the "V" wheel

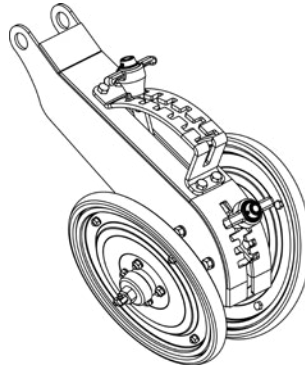

11 minor and major furrower

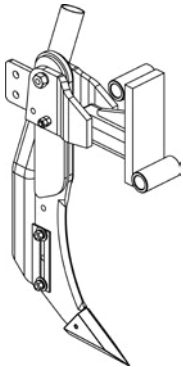

12 depth control wheel with support

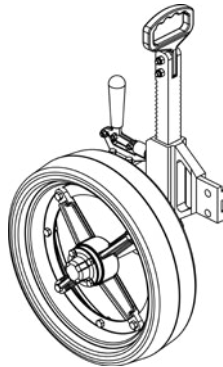

Figures 59

19 - PLANTING CARTS

DEPTH LIMITING WHEEL WITH ANGULAR ADJUSTMENT

- 1- The planting cart was developed in parallel or mismatched systems so that it can be assembled with various accessories such as:
 - Compaction wheel (1) with angle adjustment, pressure and alignment;
 - Eccentric depth control wheel (2)
- 2- - Mismatched double disc (3) for seed and fertilizer with individual cleaners;

Figures 60

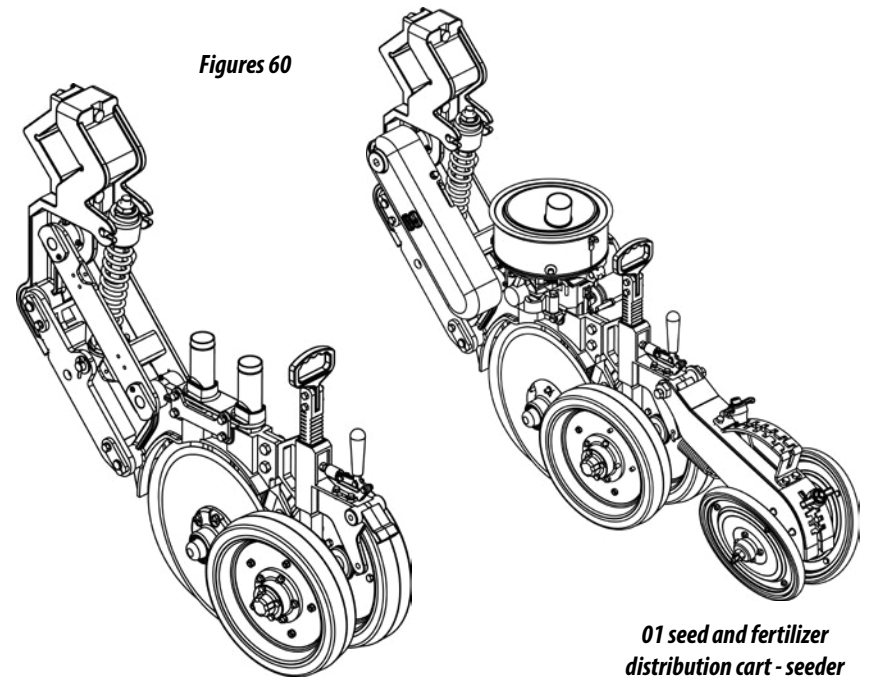

04 seed distribution cart with "V" wheel and eccentric wheel for depth control

01 seed and fertilizer distribution cart - seeder

20 – MIXING SET - OPTIONAL

- 1- - To assemble the mixing set, empty the seed box and do the following:
- 2- Place on the bottom of the seed box (1) the support (2) with screw (3), washer and nut (4), Figure 61;

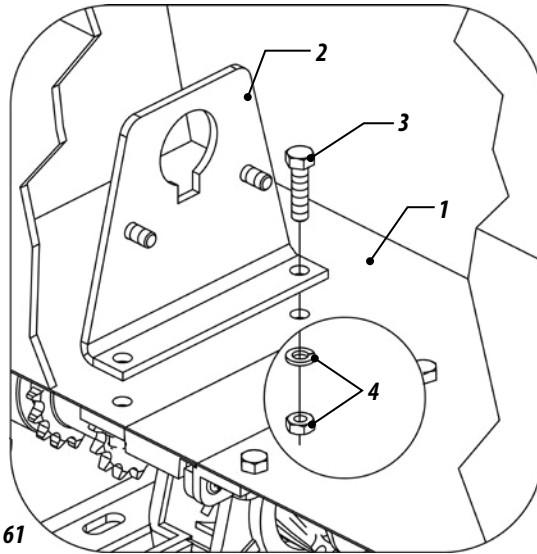

Figure 61

- 3- Fit the bearing (5) to the support and lock it with the cotter pin (6), Figure 62;

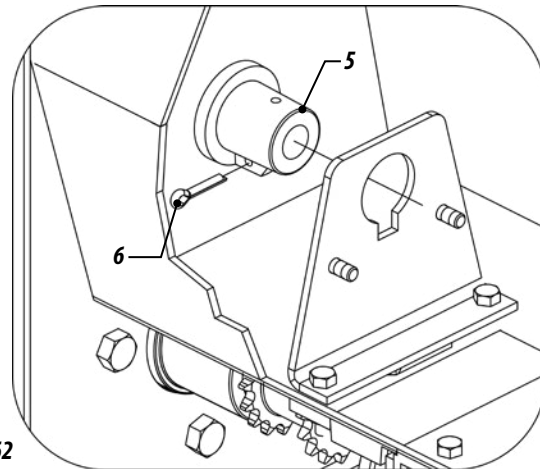

Figure 62

- 4- Then, press the shaft (7) among the mixers (8), bushing (9), fixing with screw (10), Figure 63;

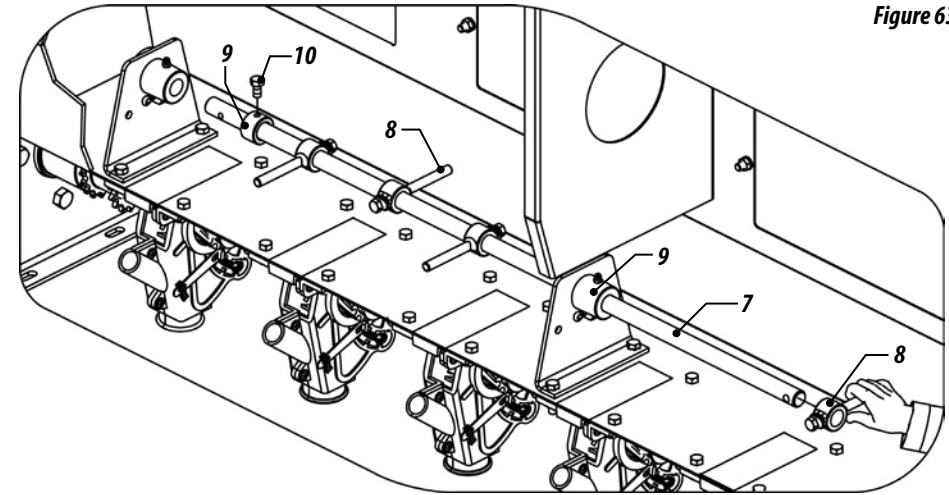

Figure 63

- 5- After assembling the shaft, place the gear (11) at the ends of the shaft with the lock (12). Make the connection of the shafts with bushing (13), screw (14), washers and nuts (15). Figure 64.

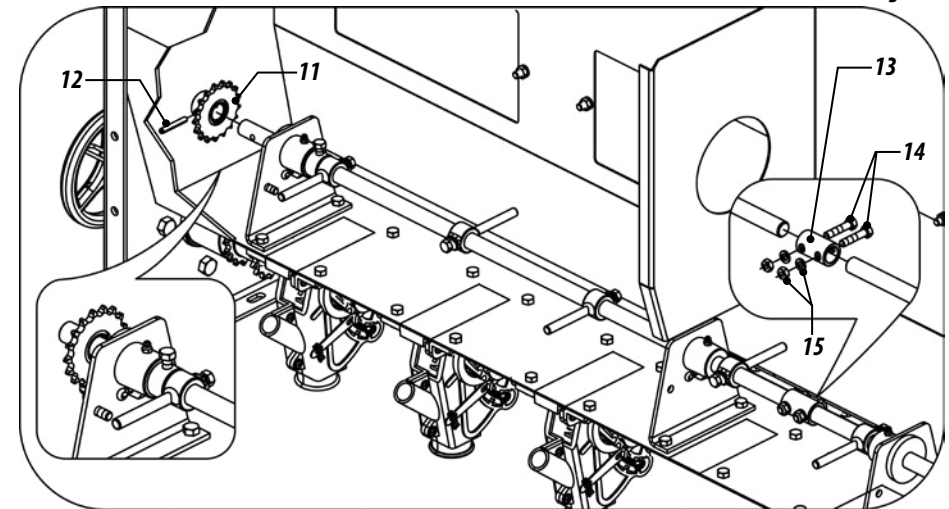
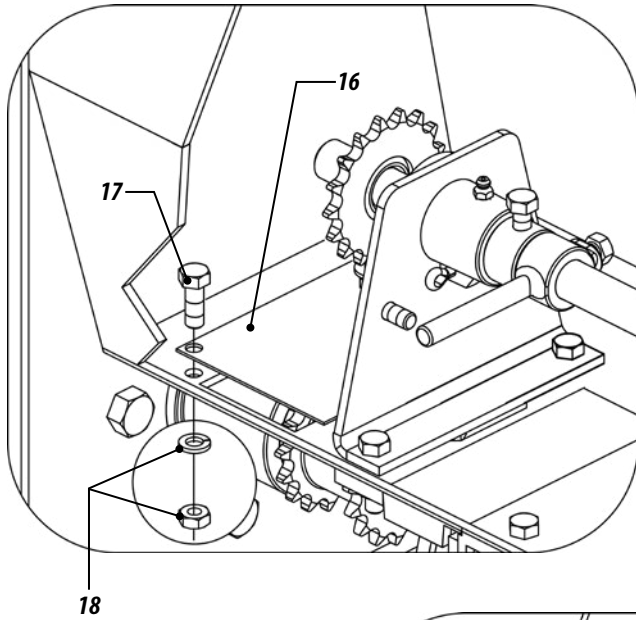
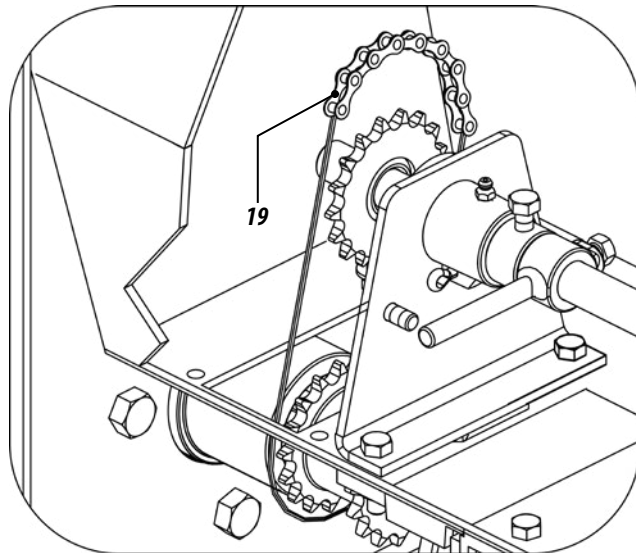

Figure 64

- 6- Remove the cap (16) by loosening the screw (17), washer and nut (18) for the placement of the chain (19). Figures 65;



Figures 65



- 7- Finally place the protective cap (20) with the wing nut (21). Tighten all screws completely. Figure 66.

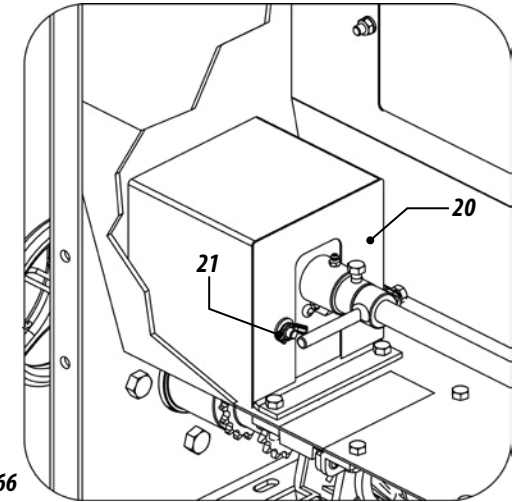

Figures 66

21 - DIGITAL HECTARE METER - BALDAN

- 1- The hectare meter leaves the factory semi-assembled, and needs the assembly of a few components, which must be assembled according to directions below:
- 2- Assemble the rear bracket (1) on the front cover (2) with screw (3), washer and nut (4), Figure 67.

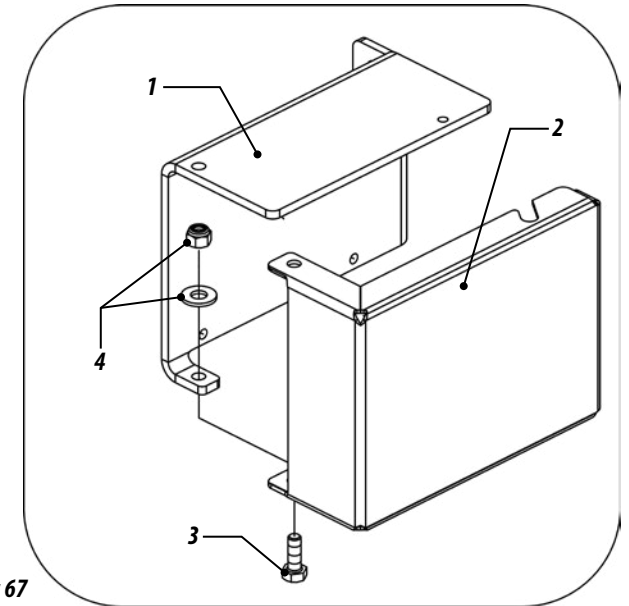

Figures 67

- 3- With the front cover open, assemble the hectare meter (5) on the support (6) with screw (7), washer and nut (8), Figure 68.

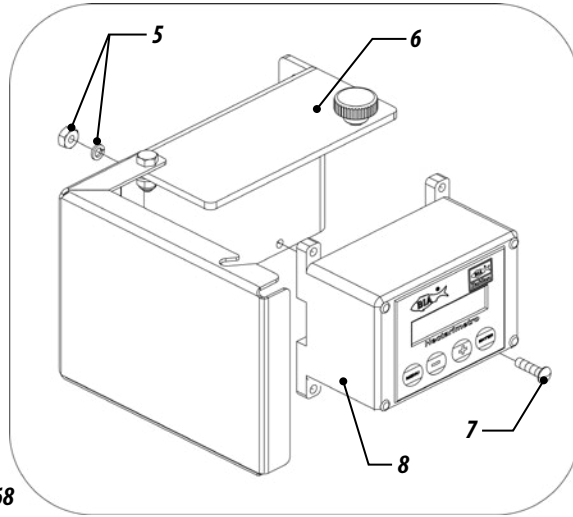

Figures 68

- 4- Place the complete protection box (9) on the chassis (10) of the seeder with screw (11), washer and nut (12), Figure 69.

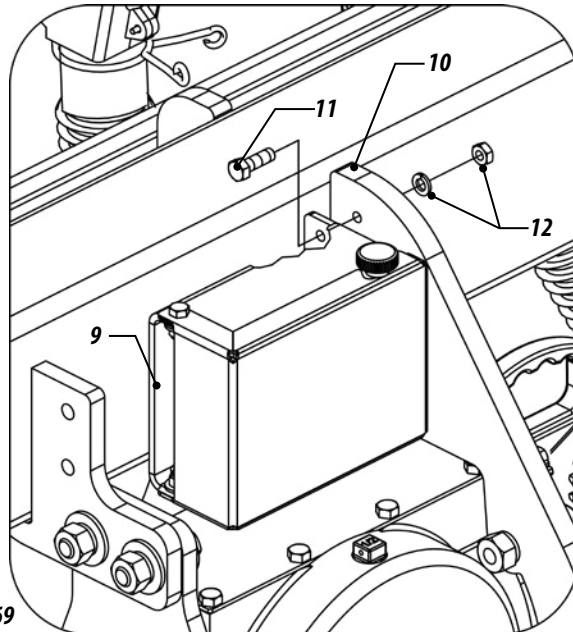

Figures 69

- 5- - Finally, install the magnetic cable that feeds the hectare meter system in the seeder transmission. For this, proceed as follows:
- 6- Place the plate (13) with screw (14), washer and nut (15) on the seeder chassis;
- 7- Insert the magnetic cable (16), fixing with washer (17) and nut (18);
- 8- Then, place the magnetic pin (19) on the transmission shaft (20) with nut (21);
- 9- Run a few meters with the seeder and make the test of reading the hectare meter, following instructions on next page. Figure 70.

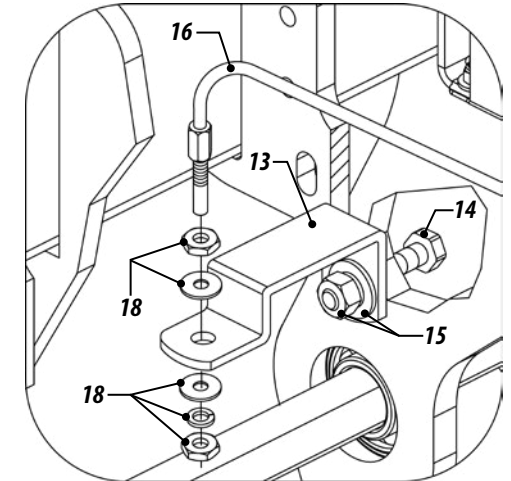
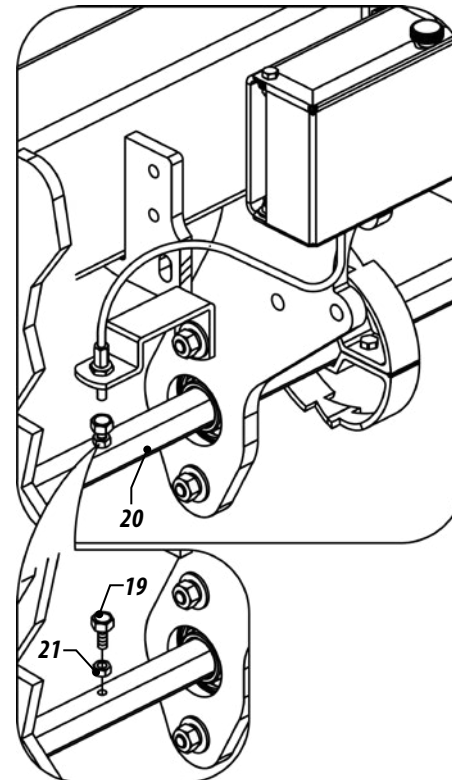

Figures 70

READING OF THE ATB DIGITAL HECTARE METER - BALDAN

1- - To operate the hectare meter, do the reading and interpretation of function keys, as follows:

1- To check HEC PARCIAL and HEC TOTAL

By pressing the MENU key, the display is turned on, the manufacturer name and battery level are shown in five (05) seconds.

After this time, the display shows the message HEC PARCIAL.

If the MENU key has been pressed again, the display shows the message HEC TOTAL. If no key is pressed within twenty (20) seconds, the system turns off the display to save battery, automatically enters into standby.

2- To reset HEC PARCIAL

By pressing the MENU key, the display is turned on, the manufacturer name and battery level are shown in five (05) seconds. After this time the display shows the message HEC PARCIAL. Hold the ENTER key pressed for (04) seconds and the system will offer the possibility to reset the HEC PARCIAL. Press MAIS to reset the HEC

PARCIAL memory or press the MENOS key to maintain the HEC PARCIAL value recorded in the memory. If no key is pressed within twenty (20) seconds, the system automatically enters into standby.

3- Setting up the Hectare meter

Press the MENU key for two (02) times so that the HEC TOTAL information is displayed. Then, press both MENOS and MAIS keys for five (05) seconds to access the configuration area. The first information presented is the NUMBER OF REVOLUTIONS OF THE TRANSMISSION SHAFT. By pressing the MENU key, the user has access to the next screen: LINE ADJUSTMENT. Use MENOS or MAIS keys to adjust the desired value. Press the MENU key for SPACING ADJUSTMENT. Follow the same procedure as above: Use MENOS or MAIS keys to set the desired value. If no key is pressed within twenty (20) seconds, the system automatically enters into standby, already considering the new values set.



BALDAN IMPLEMENTOS AGRÍCOLAS S/A.

Av. Baldan, 1500 | Nova Matão | CEP: 15993-000 | Matão-SP | Brasil

Phone: (0**16) 3221-6500 | Fax: (0**16) 3382-6500

Home Page: www.baldan.com.br | e-mail: sac@baldan.com.br

Export - Phone: 55 16 3221-6500 | Fax: 55 16 3382-4212 | 3382-2480

e-mail: export@baldan.com.br



60550104582