

## PRESENTATION

Thank you for your preference, and congratulations for the excellent choice you just made, since you acquired a state-of-art machine manufactured with advanced technology by “AGRI-TILLAGE DO BRASIL”.

This manual aims to direct you as to necessary procedures, from your acquisition to the operating procedures for use, safety and maintenance.

ATB assures that this implement has been delivered to resale complete and in perfect conditions.

Resale was responsible for keeping and conservation during the period it remained in its possession, as well as for assembly, retightening, lubrication and general review.

At technical delivery, the reseller should direct the consumer regarding maintenance, safety, obligations in occasional technical assistance, strict compliance with the warranty term and reading of instruction manual.

Any request for technical assistance under the warranty should be made to the organization where it was acquired.

When necessary consult the Baldan dealer or, in last instance, the Baldan technical department.

**INDEX**

1 - Safety Rules .....	04 - 06
2 - Components .....	07
3 - Technical Specifications .....	08
4 - Assembling and adjustments .....	09 - 25
5 - Maintenance .....	26 - 29
6 - Cleaning .....	30
7 - Preparing the tractor / Resume of adjustments and operations .....	31
9 - Identification .....	32

## 01 – SAFETY RULES



**Warning:** The incorrect handling of this equipment can result in serious or fatal accidents. Before using the implement, read carefully the instructions of this manual. Be sure that person responsible for the operation is instructed about the correct handling, safety and if read and understood the instruction manual concerning this machine.



### ATTENTION

- Do not operate the seed machine if the transmission lids are not fixed.
- The lids must be taken out only when change is a need
- Do not make any adjustments when the machine is in movement.



### ATTENTION

- The hydraulic oil works in high pressure, so it may be harmful in contact with the skin. Check periodically the hoses conditions. If there is any leakage, change them. To check any leakage use a think card, never use your hands in any case without gloves protection.
- To turn the hydraulic hoses release the pressure.



### ATTENTION

- Never stay close to the discs of the machine, they are sharpened and may cause accidents.
- To do any disc service use gloves



### ATTENTION

- Whenever the seed machine is being operated, watch out for surrounding people.
- Never stay over a platform with the machine in movement.





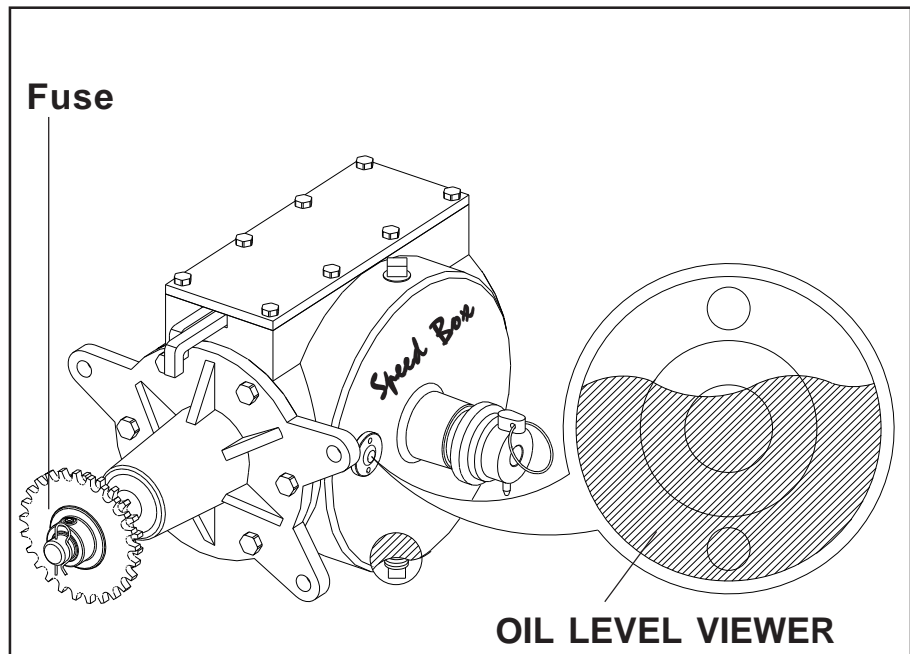
## ATTENTION

- Be careful with the row markers
- When the machines is ready to work, watch out for people close to the row markers.

















## ATTENTION

- Change speed box oil in the first 30 hours of operation. Then, change it after 1500 hours, always using SAE 140 mineral oil.
- Check oil level on a daily basis.
- Use factory-adjusted fuse only, as it has a controlled hardness.



**WARNING:** The incorrect handling of this equipment can result in serious or fatal accidents. Before using the implement, read carefully the instructions of this manual. Be sure that the person responsible for the operation is instructed about the correct handling, safety and if read and understood the instruction manual concerning this machine

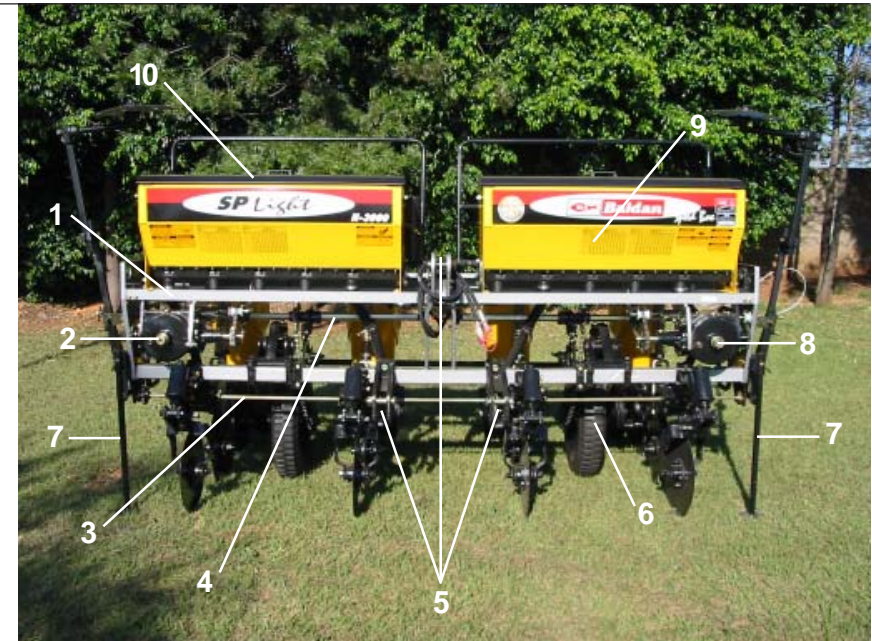


- 1 -  When operate with the implement, do not allow people to stay close or above the implement. (The platforms are used to supply the stores and not to transport people)
- 2 -  During assembly or disassembly the discs section use protection gloves.
- 3 -  When turn on or off the hydraulic hoses, alleviate the circuit pressure.
- 4 -  Check periodically the hose conservation. If there is indicium of oil emptying change it immediately because the oil works under high pressure and may cause serious damages.
- 5 -  Do not use much large clothes because they can fasten the implement.
- 6 -  Plutting in action the tractor, be correctly placed at the operator seat and aware about the correct and safety handling both tractor and implement. Place always the gearshift cranck at the neutral position, turn off the gear of the power command and place the hydraulic commands at the neutral position.
- 7 -  Do not turn on the tractor in a closed place. without appropriate ventilation because the gas is bad for health.
- 8 -  While maneuver the tractor to clamp the implement be sure if there is space enough and nobody is too close, maneuver always in slow gear and be ready to brake in case of emergency.
- 9 -  Do not make adjust the implement working.
- 10 -  Working in inclined soil try to keep the necessary stability. In case of instability reduce the acceleration, turn the wheels to the inclined side of the soil and never lift the implement.
- 11 -  Conduct the tractor always in safety speeds, specially working in irregular or inclined soil, keep the tractor always geared.
- 12 -  In case of conducting the tractor on road, keep the brake pedal connected.
- 13 -  Do not work with the front of the tractor light. If there is trend to lift up add more weight in front and of the tractor at the front wheels.
- 14 -  To leave the tractor, place the gearshift at the neutral position and apply the park brake. Do never let clamped implements to hitched the tractor with the hydraulic system at the lifted position.

## MOUNTED PRECISION ROW CROP PLANTER - SP Light

### 02 - COMPONENTS

- |                                  |                                      |
|----------------------------------|--------------------------------------|
| 01 - Frame                       | 06 - Transmission wheel              |
| 02 - Speed Box System ( seed )   | 07 - Support bar                     |
| 03 - Transmission shaft ( seed ) | 08 - Speed Box System ( fertilizer ) |
| 04 - Main transmission shaft     | 09 - Metallic Fertilizer Hopper      |
| 05 - Hitch                       | 10 - Metallic Fertilizer Hopper lid  |



- |   |
|---|
| 11 - Row Marker                               |
| 12 - Platform Rail                            |
| 13 - Rear Platform                            |
| 14 - Spring rod                               |
| 15 - Seed Hopper                              |
| 16 - "V" type compactation wheels             |
| 17 - Depth control wheels                     |
| 18 - Double discs for seed distribution       |
| 19 - Row marker lock                          |
| 20 - Double discs for fertilizer distribution |
| 21 - Cutting coulter                          |
| 22 - Fertilizer hose                          |
| 23 - Hydraulic hoses ( row marker )           |



FIGURE 01

### 03 - TECHNICAL SPECIFICATIONS

**Table 1**

<i>Model</i>	<i>Nr. of rows</i>	<i>Useful width (mm)</i>	<i>Total width (mm)</i>	<i>Fertilizer storage capacity (LT)</i>	<i>Seed storage capacity per row (LT)</i>	<i>Approx. weight (Kg)</i>	<i>Nr of wheels</i>	<i>Tyre size</i>	<i>Approx. tractor requirement (Cv)</i>	<i>Lifting capacity ** (Kg)</i>
<i>SP Light 2500</i>	<i>5 / 3</i>	<i>1800</i>	<i>2200</i>	<i>250</i>	<i>45</i>	<i>960</i>	<i>2</i>	<i>Militar 5.6 x 15-10 Lonas</i>	<i>60 - 65 (4 x 4) ou (4 x 2) w/ weights</i>	<i>2100</i>
<i>SP Light 2500</i>	<i>5 / 4</i>	<i>1800</i>	<i>2200</i>	<i>250</i>	<i>45</i>	<i>1120</i>	<i>2</i>	<i>Militar 5.6 x 15-10 Lonas</i>	<i>75 - 80 (4 x 4) ou (4 x 2) w/ weights</i>	<i>2500</i>
<i>SP Light 2500</i>	<i>5 / 5</i>	<i>1800</i>	<i>2200</i>	<i>250</i>	<i>45</i>	<i>1280</i>	<i>2</i>	<i>Militar 5.6 x 15-10 Lonas</i>	<i>75 - 80 (4 x 4)</i>	<i>3000</i>
<i>SP Light 3000</i>	<i>6 / 4</i>	<i>2700</i>	<i>3100</i>	<i>320</i>	<i>45</i>	<i>1180</i>	<i>2</i>	<i>Militar 5.6 x 15-10 Lonas</i>	<i>75 - 80 (4 x 4) ou (4 x 2) w/ weights</i>	<i>3000</i>
<i>SP Light 3000</i>	<i>6 / 5</i>	<i>2700</i>	<i>3100</i>	<i>320</i>	<i>45</i>	<i>1340</i>	<i>2</i>	<i>Militar 5.6 x 15-10 Lonas</i>	<i>75 - 80 (4 x 4)</i>	<i>3000</i>
<i>SP Light 3000</i>	<i>6 / 6</i>	<i>2700</i>	<i>3100</i>	<i>320</i>	<i>45</i>	<i>1500</i>	<i>2</i>	<i>Militar 5.6 x 15-10 Lonas</i>	<i>75 - 80 (4 x 4)</i>	<i>3000</i>

- *Minimum spacing between rows* ..... 400 mm
- *Minimum spacing between rows ( within tyres )* ..... 400 mm
- *Working depth* ..... 0 a 120 mm
- *Total height* ..... 1600 mm
- *Total length* ..... 2100 mm
- *Fertilizer flow range* ..... 83 - 2263 kg/ha

*\* Hydraulic row markers and rear platform are not included on the approx. weight.*

*\*\* Lifting capacity at tractor hitching beam grommet.*

ATB reserves the right to change product's technical characteristics without prior notice. Technical specification are approximated and informed under regular conditions of work.

## 04 – ASSEMBLY AND PREPARATION FOR PLANTING

### SPACING BETWEEN ROWS

1 - The planter is supplied with spacings according to the number of rows. New spacing can be set according to the different cultures.

### POSITION OF THE ROWS ON THE FRAME (FIGURE 02)

1 - First mark the frame, where the row units will be fixed. For even number of rows, fix the first unit in the center of the frame, then fix the others according to the desired spacing.

2 - For odd number of rows, mark the center of the frame. Divide and mark 1/2 spacing on each side and fix the two first rows. Then fix all other rows according to the desired spacing.

**THE MINIMUM SPACING BETWEEN ROWS,  
WITHIN THE WHEELS IS 400 MM.**

SP *Light* 2500

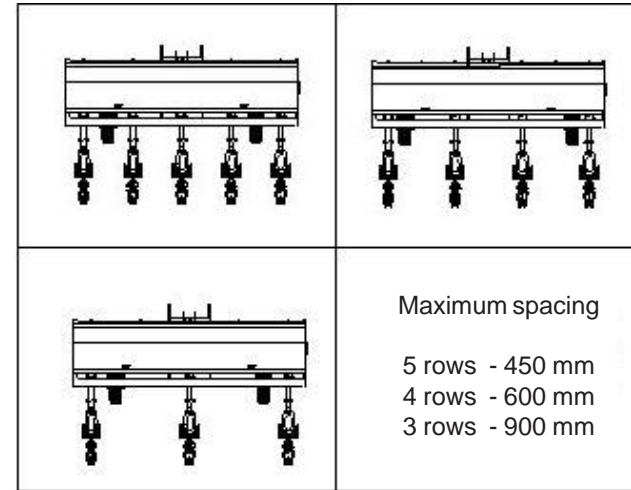
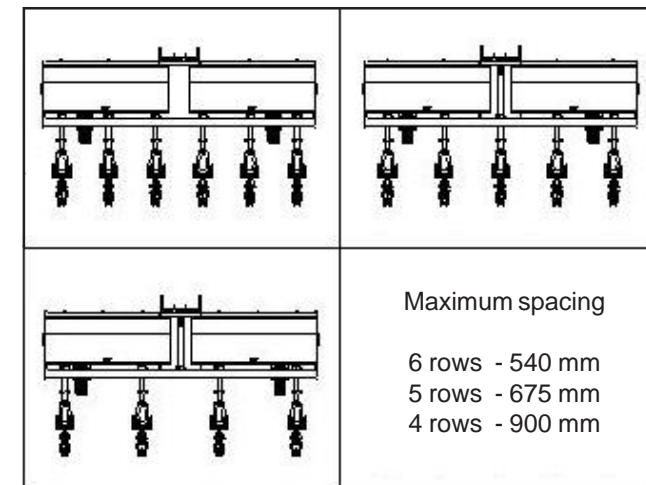


FIGURE 02

SP *Light* 3000



### SETTING NEW SPACINGS (FIGURE 03)

1 - In order to set new spacings between rows, lift up and use the support to stand the planter.

2 - In order to set new spacings, you will have to take off some rows and increase the spacing. Please proceed as follows :

- Take off lock pin (1) from one of the ends of the shaft, and loosen bolts (2) that fix the transmission sprocket., Loosen bolt (3) making locks (4) free. Take off the transmission shaft (5).

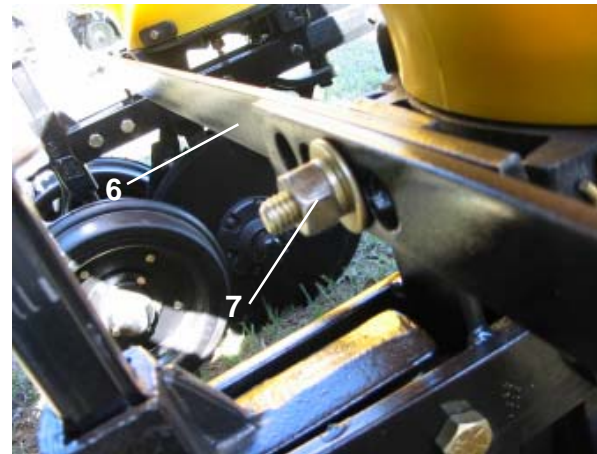
- Identify the rows that will be taken off or displaced. Loosen the nuts from the spring supports taking off the brackets and the spacing lock bars (6) through washer and nut (7). The row unit should come off or be displaced completely.

- The row units come out by pulling them from the rear side of the planter.

- You can also slide the row units to the desired spacing and tighten all bolts and nuts again.

- Replace transmission shaft (5) and lock (1). Line up the sprocket and retighten bolts (2 and 3) .

- Replace and fix the lock bars (6), according to the new spacing. Also make sure that all spring rods (14) are in the absolute vertical position.



**FIGURE 03**

## WHEEL SPACINGS (FIGURE 04)

- 1 - In order to modify the wheel position, loosen nuts (1) of both lock supports and wheel clamps.
- 2 - Loosen sprocket (2) using lock bushing (3). The wheel unit is now ready to be moved.
- 3 - Slide wheel and ratchet sets to the desired position, retighten nuts (1) and lock the ratchet with lock bushing (3).
- 4 - Check the alignment of wheel sprocket (5) with the shaft sprocket (2) and also the transmission chain (4).

FIGURE 04



**IMPORTANT: Check the alignment between both sprockets.**

## PREPARING FOR PLANTING

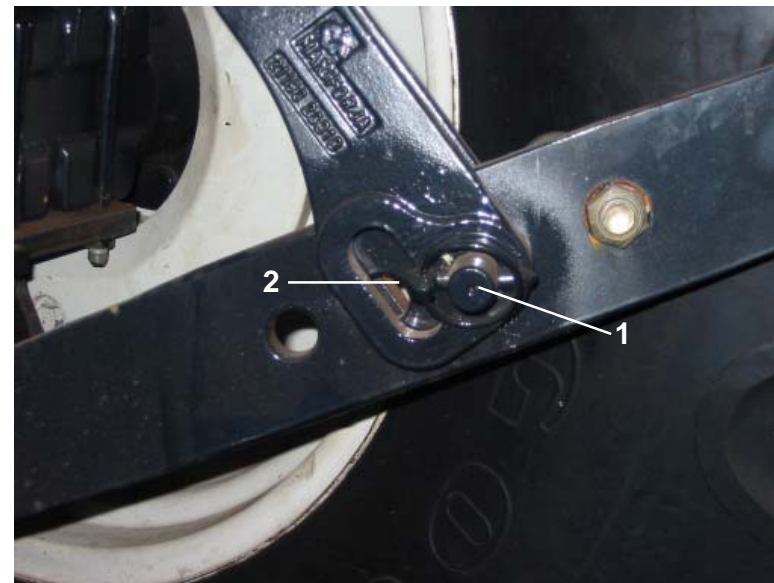
It is very important to prepare the planter before planting operation. In case you have any problems, please contact our after sales department. ( [assist.tecnica@agritillage.com.br](mailto:assist.tecnica@agritillage.com.br) )

## SETTING THE TRACTOR FOR HITCHING

For unlevelled areas, set the pin of the tractors hydraulic arms on the oscillating position. ( **FIGURE 05** )

- 1 - Take off pin (1) from the fix point and change to the oscillating point (2).

FIGURE 05



Obs.: This will provide flotation to the planter behind the tractor, helping to maintain a better depth control of seed and fertilizer.

## CUTTING COULTER DEPTH ADJUSTMENT (FIGURE 06)

This planter was projected and built to work in No-Till conditions, but can also work in tilled areas. In this case, the cutting coulters are not necessary.

1 - In order to adjust the cutting coulters (1), loosen bolts (2) and move bar (3) to the desired cutting depth.

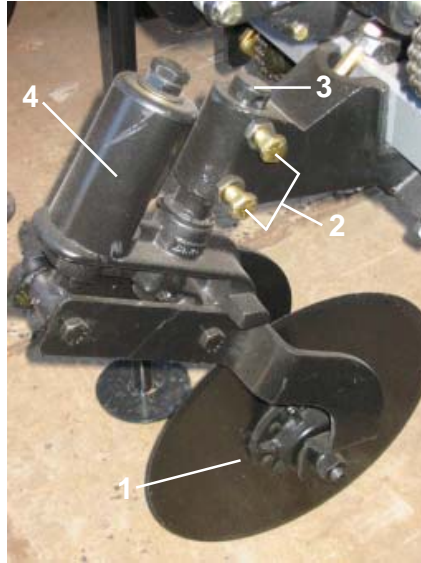


FIGURE 06



Spring (4) is calibrated at the factory and should not be modified.

## ADJUSTMENT OF THE FERTILIZER DISTRIBUTORS.

The fertilizer distribution can be done using double discs or furrowers.

The depth calibration is done through the triple spring device located on each fertilizer row unit.

## DOUBLE DISCS (FIGURE 07)

The calibration should be done after the planter is hitched to the tractor.

1 - Loosen bushing (1) and set it in order to adjust the row flotation. Normally fix it 10 cm above the base.

2 - Loosen bushing (2) to set the depth pressure. In order to have more pressure, lift up the planter and fix the bushing (2) on a higher position of the rod.

## SPRING PRESSURE ADJUSTMENT OF THE PLANTING ROW (FIGURE 07)

1 - Loosen bushing (3) and set it in order to adjust the row flotation.

2 - After lifting the planter, loosen bushing (4) and fix it on the upper position of the rod. That will give more pressure to the planting row unit.

Obs.: Never use too much pressure on the row units. It could cause damage to the unit.



**IMPORTANT :** The penetration capacity is related to the correct pressure adjustment of the spring rod.

FIGURE 07



## DOUBLE DISC SCRAPER ADJUSTMENT (FIGURE 08)



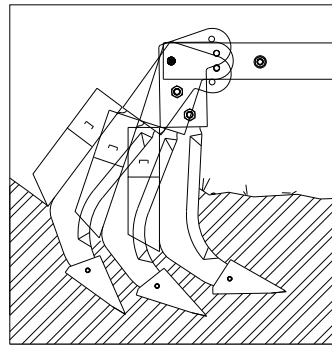
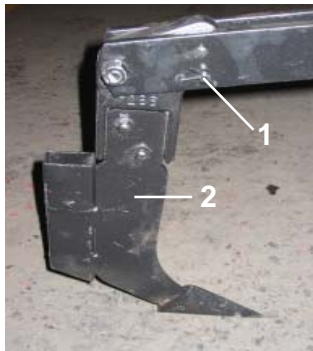
1 - Double disc unit have scrapers (1) which are flexible and adjusted through bolts (2). It's function is to clean the soil that adheres to the discs. The scrapers should be replaced periodically.

**FIGURE 08**

## FURROWER POSITION

1 - The furrower can work in two positions. The working angle can be adjusted by changing the position by pin (1). This will make the furrower (1) working in a different angle.

Obs.: Pin (1) is also a safety device. It should only be replaced by a original Baldan part.

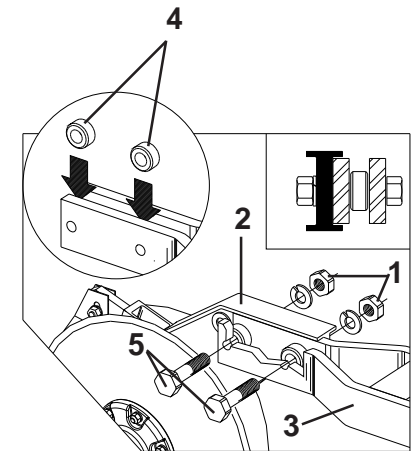
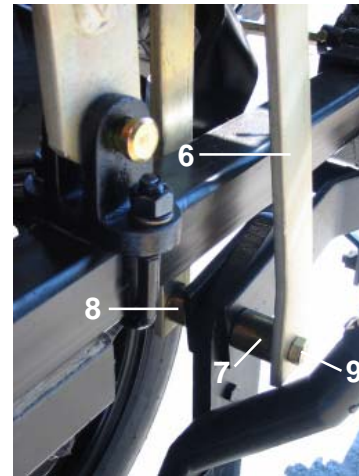


**FIGURE 09**

## FURROW OPENING AND FERTILIZER POSITION IN THE SOIL. (FIGURE 10)

The furrow opening in the soil can be done using the double discs or the furrower device. The fertilizer is applied by the following systems :

- Lateral and under the seed ( double discs )
- Under the seed in the same line ( furrower ) - deep fertilizing



**FIGURE 10**

The row units are normally set by the factory in order to fertilize in the same line, under the seed. For lateral fertilizing, proceed as follows :

Remove spring rod (6), loosen nuts (1), remove unit (2) that is located between fork bar (3), replace it to one of the sides of the fork bar. Place bushings (4) between the fork and fix it through bolts (5) washers and nuts (1), according to **FIGURE 10**. Next, replace spring rod (6), placing bushing - large (7) and small (8) on the same side the unit was placed. Fix it through pin and nut (9).

## SEED DEPTH CONTROL WHEEL AND “V” COMPACTATION WHEEL (FIGURES 11 and 12)

- 1 - Seed depth is controlled by oscillating depth wheels (1), which are adjusted through bolt (2).
- 2 - Wheels are fastened to a shaft with graduate ends (3), specially designed to allow compactation, depth control and cover the seeds. In order to achieve such adjustment, loosen nut (4) and turn shaft (3), checking the wheels angular movements :
- **Parallel position** : For soil compactation without accumulating soil on the seeds. ( dry soils )
- **Opened position** : For wet conditions when you need more soil to cover seeds.



FIGURE 12

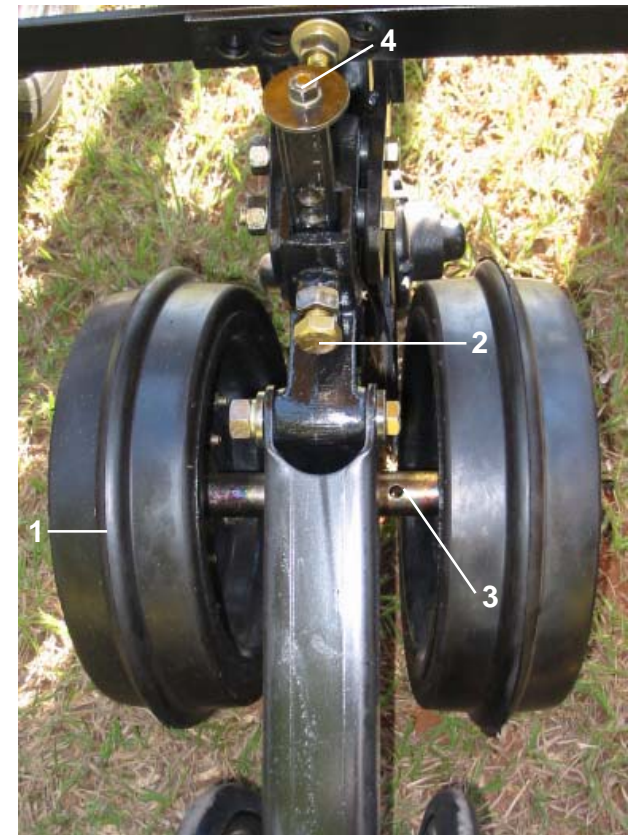


FIGURE 11

- 3 - The ‘V’ compactation wheels are adjusted through pin (5). For more pressure, pull pin (5) and lock with conical pin (6).

**IMPORTANT :** After finishing all adjustments, check if there are no tools or parts in the seed or fertilizer hoppers. retighten all bolts and nuts. Also check if all hoses are fixed.

## ROW MARKER ADJUSTMENTS (Figure 21)

- 14 - Row marker adjustment is important to have a plantation with uniform spacing.
- 15 - To adjust row markers, spacing between rows, the number of rows to be used in the operation and the tractor's front gauge should be known.
- 16 - Use the formula described below, followed by an example.

- Example: For a 6-row planter, spacing of 0.90m spacing and tractor's front gauge with 1.43m, determine:

17 - Formula: 
$$D = \frac{E \times (N+1) - B}{2}$$

**Solve:** 
$$D = \frac{0,90 \times 7 - 1,43}{2}$$

$$D = 2,43 \text{ meters}$$

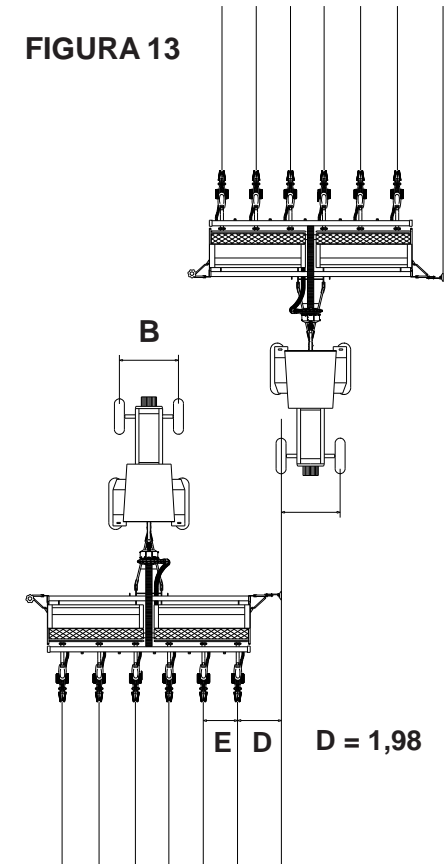
Where:

E = Spacing between rows  
 N = Number of rows at the planter  
 B = Tractor's front gauge  
 D = Marker distance

- 18 - Adjust row marker disc with 2.43m from the center of the first plantation row.
- 19 - The row markers are intermittent what means that if during the planting before determining the row it is necessary to stop the work, turn on the piston to lift and bring down the seed machine twice to continue the work with the marker at the right side.



FIGURA 14



## SEED ADJUSTMENT SP *Light*

### SEED DISTRIBUTING PLATES (Figure 15)

In order to change or replace distributing plates, open seed box, remove butterfly bolt (1), top support with deflector (2) and the distributing plate (3) to be changed.

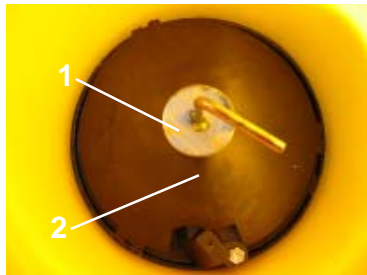


FIGURE 15



### SEED DISTRIBUTOR STAR (Figure 17)

Seed distributor leaves factory assembled with trigger of two distributing stars (1), for use in double hole row plates (2).

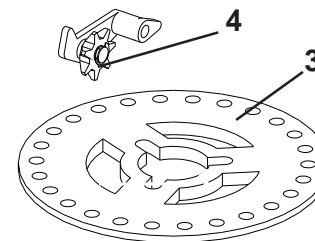
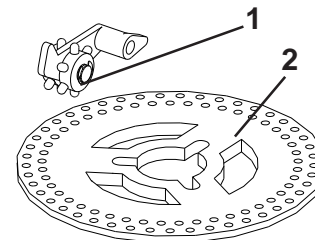


FIGURE 17

Plates with single hole row (3) use trigger of one dispensing star (4). For trigger change, refer to figure 22.

Choose the desired distributing plate and proceed assembly thereof at the seed box. Check placement of rings according to seed distributing plates as follows:

- For a 3mm distributing plate, use a 5mm plastic ring and one 3.5mm metallic ring;
- For a 4.5mm distributing plate, use two 3.5mm metallic rings;
- For a 8mm distributing plate, use one 3.5mm metallic ring.

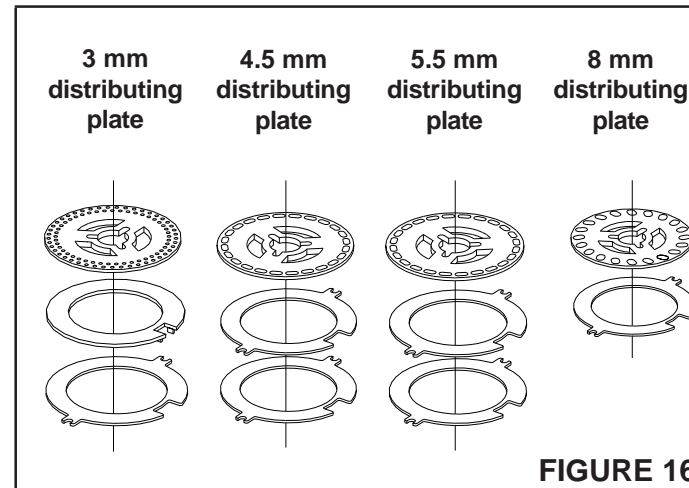


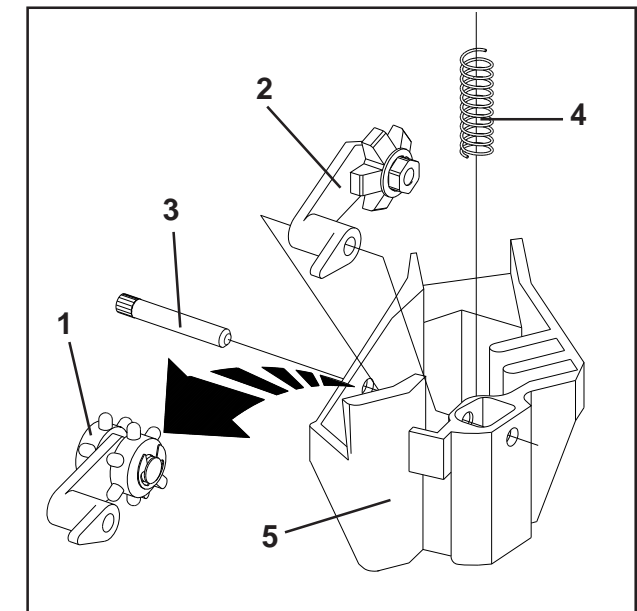
FIGURE 16

### REPLACEMENT OF DOUBLE TRIGGER WITH A SINGLE TRIGGER (Figure 18)

Seed distributor leaves factory with trigger of two distribution stars (1) for double hole row plates. In order to replace it with a one-star trigger (2) remove pin (3), the trigger (1), place spring (4) into the fit, insert trigger (2) into box (5) and lock with pin (3).



FIGURE 18



## SEED ADJUSTMENT *Speed Box* (FIGURE 19)

1 - Seed adjustment is performed through the Speed Box system (2), located on the right side of the planter (rear view). In order to achieve more combinations, you should interchange sprockets "A" (motor) and "B" (moved).

2 - In case you have to interchange the sprockets, check the chain tension. Stretcher (1) is provided with torsion spring for better flexibility.

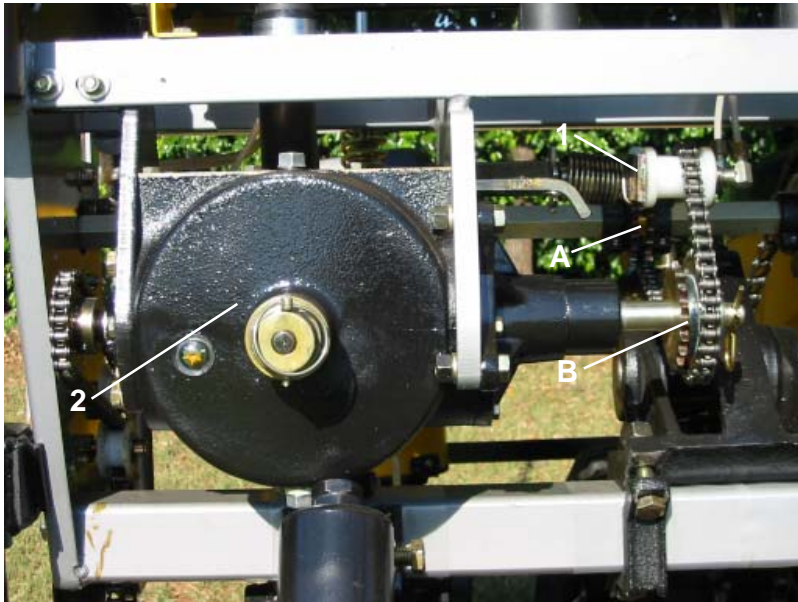


FIGURE 19

## SEED DISTRIBUTION TABLE (TABLES 02 and 03)

Check seed distribution tables in order to see quantity distribution references.

**IMPORTANT :** The seed distribution tables are based on one seed per seed plate hole.

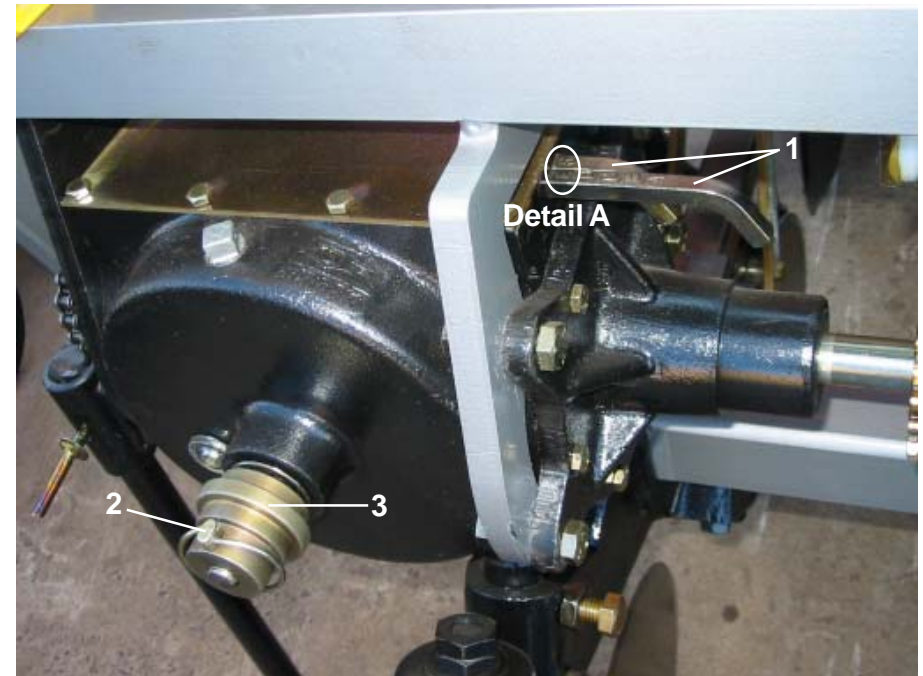
## SPEED BOX SYSTEM (FIGURE 19)

1 - Planter is provided with a Speed Box, that drives a distribution system with simple adjustments (Tools free).

2 - To calibrate the seed quantity per linear meter, choose the correct seed plate and select the desired combination using the number / letter lever (1). Exemplo: Combination **E 6** - detail **A** on **FIGURE 20**, indicates that the letter lever should be placed on position "E" and the number lever should be on position "6" according to **FIGURE 20**.

3 - In order to move levers, remove safety pin (2), pull the handling (3), and find the resired position ( combination ). After placing both levers, push back the handling (3) and lock with safety pin (2).

FIGURE 20



SEED DISTRIBUTION TABLE (PER LINEAR METER)														
Main Shaft Cog					20	Speed Box Cog					25			
Speed Box Combinations	Number of holes on the seed distribution plates													
	19	20	24	26	30	38	40	48	50	62	64	72	90	
F - 1	1,7	1,8	2,2	2,4	2,8	3,5	3,7	4,4	4,6	5,7	5,9	6,6	8,3	
F - 2	1,9	2,1	2,5	2,7	3,1	3,9	4,1	5,0	5,2	6,4	6,6	7,4	9,3	
E - 1	2,1	2,3	2,8	3,0	3,4	4,4	4,6	5,5	5,7	7,1	7,3	8,3	10,3	
F - 3	2,1	2,4	2,8	3,1	3,5	4,5	4,7	5,7	5,9	7,3	7,6	8,5	10,6	
E - 2	2,3	2,6	3,1	3,4	3,9	4,9	5,2	6,2	6,5	8,0	8,3	9,3	11,6	
D - 1	2,5	2,8	3,3	3,6	4,1	5,2	5,5	6,6	6,9	8,5	8,8	9,9	12,4	
F - 4	2,5	2,8	3,3	3,6	4,1	5,2	5,5	6,6	6,9	8,5	8,8	9,9	12,4	
E - 3	2,7	3,0	3,5	3,8	4,4	5,6	5,9	7,1	7,4	9,2	9,4	10,6	13,3	
D - 2	2,8	3,1	3,7	4,0	4,7	5,9	6,2	7,4	7,8	9,6	9,9	11,2	14,0	
C - 1	2,9	3,2	3,9	4,2	4,8	6,1	6,4	7,7	8,0	10,0	10,3	11,6	14,5	
F - 5	3,0	3,3	4,0	4,3	5,0	6,3	6,6	7,9	8,3	10,3	10,6	11,9	14,9	
E - 4	3,1	3,4	4,1	4,5	5,2	6,5	6,9	8,3	8,6	10,7	11,0	12,4	15,5	
D - 3	3,2	3,5	4,3	4,6	5,3	6,7	7,1	8,5	8,9	11,0	11,3	12,8	15,9	
C - 2	3,3	3,6	4,3	4,7	5,4	6,9	7,2	8,7	9,0	11,2	11,6	13,0	16,3	
B - 1	3,3	3,7	4,4	4,8	5,5	7,0	7,3	8,8	9,2	11,4	11,8	13,2	16,5	
A - 1	3,7	4,1	5,0	5,4	6,2	7,9	8,3	9,9	10,3	12,8	13,2	14,9	18,6	
A - 2	4,2	4,7	5,6	6,0	7,0	8,8	9,3	11,2	11,6	14,4	14,9	16,7	20,9	
B - 3	4,3	4,7	5,7	6,1	7,1	9,0	9,4	11,3	11,8	14,6	15,1	17,0	21,3	
C - 4	4,4	4,8	5,8	6,3	7,2	9,2	9,6	11,6	12,1	15,0	15,4	17,4	21,7	
D - 5	4,5	5,0	6,0	6,4	7,4	9,4	9,9	11,9	12,4	15,4	15,9	17,9	22,3	
E - 6	4,7	5,2	6,2	6,7	7,8	9,8	10,3	12,4	12,9	16,0	16,5	18,6	23,3	
A - 3	4,8	5,3	6,4	6,9	8,0	10,1	10,6	12,8	13,3	16,5	17,0	19,1	23,9	
B - 4	5,0	5,5	6,6	7,2	8,3	10,5	11,0	13,2	13,8	17,1	17,6	19,8	24,8	
C - 5	5,2	5,8	6,9	7,5	8,7	11,0	11,6	13,9	14,5	17,9	18,5	20,8	26,0	
D - 6	5,6	6,2	7,4	8,1	9,3	11,8	12,4	14,9	15,5	19,2	19,8	22,3	27,9	
A - 4	5,6	6,2	7,4	8,1	9,3	11,8	12,4	14,9	15,5	19,2	19,8	22,3	27,9	
B - 5	6,0	6,6	7,9	8,6	9,9	12,6	13,2	15,9	16,5	20,5	21,2	23,8	29,8	
C - 6	6,6	7,2	8,7	9,4	10,9	13,7	14,5	17,4	18,1	22,4	23,1	26,0	32,6	
A - 5	6,7	7,4	8,9	9,7	11,2	14,1	14,9	17,9	18,6	23,1	23,8	26,8	33,5	
B - 6	7,5	8,3	9,9	10,7	12,4	15,7	16,5	19,8	20,7	25,6	26,5	29,8	37,2	
A - 6	8,4	9,3	11,2	12,1	14,0	17,7	18,6	22,3	23,3	28,8	29,8	33,5	41,9	

Table 02

SEED DISTRIBUTION TABLE ( PER LINEAR METER )													
Main Shaft Cog					25				Speed Box Cog				20
Speed Box Combinations	Number of holes on the seed distribution plates												
	19	20	24	26	30	38	40	48	50	62	64	72	90
F - 1	2,6	2,9	3,4	3,7	4,3	5,5	5,7	6,9	7,2	8,9	9,2	10,3	12,9
F - 2	2,9	3,2	3,9	4,2	4,8	6,1	6,5	7,8	8,1	10,0	10,3	11,6	14,5
E - 1	3,3	3,6	4,3	4,7	5,4	6,8	7,2	8,6	9,0	11,1	11,5	12,9	16,1
F - 3	3,3	3,7	4,4	4,8	5,5	7,0	7,4	8,9	9,2	11,4	11,8	13,3	16,6
E - 2	3,7	4,0	4,8	5,2	6,1	7,7	8,1	9,7	10,1	12,5	12,9	14,5	18,2
D - 1	3,9	4,3	5,2	5,6	6,5	8,2	8,6	10,3	10,8	13,3	13,8	15,5	19,4
F - 4	3,9	4,3	5,2	5,6	6,5	8,2	8,6	10,3	10,8	13,3	13,8	15,5	19,4
E - 3	4,2	4,6	5,5	6,0	6,9	8,8	9,2	11,1	11,5	14,3	14,8	16,6	20,8
D - 2	4,4	4,8	5,8	6,3	7,3	9,2	9,7	11,6	12,1	15,0	15,5	17,4	21,8
C - 1	4,6	5,0	6,0	6,5	7,5	9,5	10,0	12,1	12,6	15,6	16,1	18,1	22,6
F - 5	4,7	5,2	6,2	6,7	7,8	9,8	10,3	12,4	12,9	16,0	16,5	18,6	23,3
E - 4	4,9	5,4	6,5	7,0	8,1	10,2	10,8	12,9	13,5	16,7	17,2	19,4	24,2
D - 3	5,0	5,5	6,6	7,2	8,3	10,5	11,1	13,3	13,8	17,2	17,7	19,9	24,9
C - 2	5,1	5,7	6,8	7,3	8,5	10,7	11,3	13,6	14,1	17,5	18,1	20,3	25,4
B - 1	5,2	5,7	6,9	7,5	8,6	10,9	11,5	13,8	14,4	17,8	18,4	20,7	25,8
A - 1	5,9	6,5	7,8	8,4	9,7	12,3	12,9	15,5	16,1	20,0	20,7	23,3	29,1
A - 2	6,6	7,3	8,7	9,4	10,9	13,8	14,5	17,4	18,2	22,5	23,3	26,2	32,7
B - 3	6,7	7,4	8,9	9,6	11,1	14,0	14,8	17,7	18,5	22,9	23,6	26,6	33,2
C - 4	6,8	7,5	9,0	9,8	11,3	14,3	15,1	18,1	18,8	23,4	24,1	27,1	33,9
D - 5	7,0	7,8	9,3	10,1	11,6	14,7	15,5	18,6	19,4	24,0	24,8	27,9	34,9
E - 6	7,3	8,1	9,7	10,5	12,1	15,3	16,1	19,4	20,2	25,0	25,8	29,1	36,3
A - 3	7,5	8,3	10,0	10,8	12,5	15,8	16,6	19,9	20,8	25,7	26,6	29,9	37,4
B - 4	7,8	8,6	10,3	11,2	12,9	16,4	17,2	20,7	21,5	26,7	27,6	31,0	38,8
C - 5	8,2	9,0	10,9	11,8	13,6	17,2	18,1	21,7	22,6	28,0	28,9	32,6	40,7
D - 6	8,8	9,7	11,6	12,6	14,5	18,4	19,4	23,3	24,2	30,0	31,0	34,9	43,6
A - 4	8,8	9,7	11,6	12,6	14,5	18,4	19,4	23,3	24,2	30,0	31,0	34,9	43,6
B - 5	9,4	10,3	12,4	13,4	15,5	19,6	20,7	24,8	25,8	32,0	33,1	37,2	46,5
C - 6	10,3	11,3	13,6	14,7	17,0	21,5	22,6	27,1	28,3	35,0	36,2	40,7	50,9
A - 5	10,5	11,6	14,0	15,1	17,4	22,1	23,3	27,9	29,1	36,0	37,2	41,9	52,3
B - 6	11,7	12,9	15,5	16,8	19,4	24,5	25,8	31,0	32,3	40,0	41,3	46,5	58,1
A - 6	13,2	14,5	17,4	18,9	21,8	27,6	29,1	34,9	36,3	45,1	46,5	52,3	65,4

Table 03

## SEED DISTRIBUTION PLATES

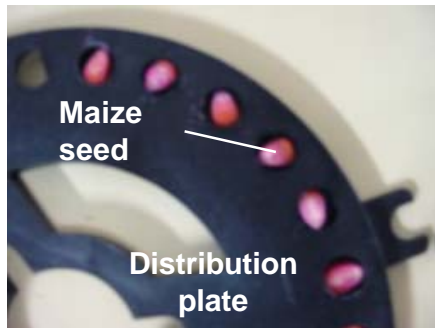
The planter is supplied with 7 sets of seed plates. Optional plates are also available and can be supplied separately, as spare parts. Please indicate the optional plates when ordering the planter, by informing the parts number ( code ).

**Table 04**

TYPE OF SEED	STANDARD SEED PLATES	
SOYA	90 Holes (8,5 x 9,0 mm)	x 4,5 mm
	40 Holes (8,0 x 15,0 mm)	x 8,0 mm
	40 Holes (7,5 x 15,0 mm)	x 8,0 mm
MAIZE / RICE	26 Holes (13,5 mm)	x 4,5 mm
	26 Holes (13,0 mm)	x 4,5 mm
	26 Holes (11,0 mm)	x 4,5 mm
BEANS	72 Holes (7,0 x 12,0 mm)	x 5,5 mm

### \* MAIZE (FIGURE 21)

1 - In order to choose the correct plate to distribute maize, you first have to collect seed samples from the lot that will be used, and check if they fit in the seed plate holes ( only one seed per hole ). Notice that the seed has to pass through the hole. In case to have double seeds per hole, or the seed does not pass, try another seed plate, until you find the best option.



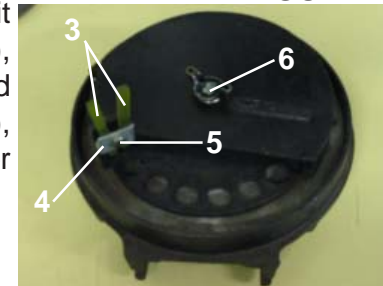
**FIGURA 21**

TYPE OF SEED	OPTIONAL SEED PLATES	
SOYA	38 holes (7,5 x 18,0 mm)	x 4,5 mm
	38 holes (8,0 x 18,0 mm)	x 4,5 mm
	62 holes (8,5 x 9,0 mm)	x 4,5 mm
MAIZE	24 holes (9,0 x 14,0 mm)	x 4,5 mm
	24 holes (10,0 x 15,0 mm)	x 4,5 mm
	24 holes (11,0 x 15,0 mm)	x 4,5 mm
	48 holes (9/32")	x 4,5 mm
SORGHUM	50 holes (4,8 mm)	x 3,0 mm
	90 holes (5 x 5,5 mm)	x 3,0 mm
BEANS	64 holes (8,0 x 12,0 mm)	x 5,5 mm
PEANUTS**	19 holes (19,0 mm)	x 6,0 mm
SUNFLOWER	20 holes (7,0 x 16,0 mm)	x 4,5 mm
COTTON W/O LINTER	30 holes (5,5 x 11,0 mm)	x 4,5 mm
	40 holes (7,5 x 12,5 mm)	x 4,5 mm
OTHERS	17 holes (9/32")	x 3,0 mm
	18 holes (9/32")	x 3,0 mm
	30 holes (8,5 x 12,0 mm)	x 4,5 mm
	30 holes (9,0 x 13,5 mm)	x 4,5 mm
	30 holes (10,0 x 14,5 mm)	x 4,5 mm
	30 holes (11,0 x 15,5 mm)	x 4,5 mm
	40 holes (8,0 x 13,5 mm)	x 4,5 mm
	90 holes (5,0 x 5,5 mm)	x 3,0 mm
	90 holes (7,0 x 7,5 mm)	x 4,5 mm
	Blank seed plates for special holes.	

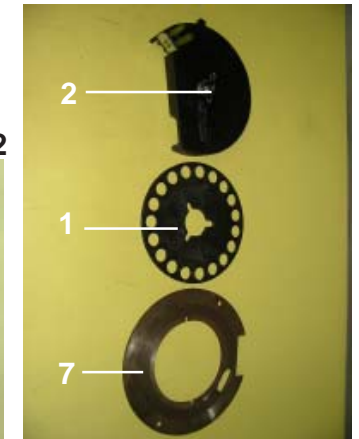
**Obs.:** The total thickness of seed plate and rings should be 11.5 mm. This is very important, otherwise the system will lock and damage the transmission system. Check if all rows are assembled correctly before running the planter

### \*\* PEANUTS (FIGURE 22)

1 - For peanuts, use the special kit with a 19 holes x 3/4" x 6mm (1), internal flow regulator (2) seed fingers (3), seed finger support (4), bolt, nut and washer (5), nut/washer (6) and dual side metallic ring (7).



**FIGURE 22**



## FERTILIZER DISTRIBUTION SYSTEMS (Figure 23)

- 01 - Floating coil fertilizer distribution system consists of a shaft arranged in the bottom of the fertilizer hopper, which when beginning to rotate, the fertilizer involves shaft, thereby transporting it to outlets, without needing intermediate bearings.
- 02 - When determining the number of rows and spacing desired, couple hoses (1) to fertilizer tube (2), making connection of hoses which are nearest to rows, thereby preventing the same to become crossed or folded. For a better alignment of hoses, use the graduate tube (3) if necessary, according to details.
- 03 - Outlets which will not be used should be closed with caps (4) inside the hopper and with plug (5) in external outlets. This will prevent fine particles of fertilizer falling on the planter.
- 04 - Se for any reason the fertilizer exits get blocked stopping the distribution an the row, the fertilizer will start coming out through. The safety outlets, advising the operator that the row should be checked. (figure 27)

**ATTENTION**  
**REMOVE PLUG (2) CLEANING THE OUTLETS ON DAILY**  
**BASIS.**

**FIGURE 23**



## FERTILIZER CALIBRATION *Speed Box* (FIGURE 24)

- 1 - The fertilizer calibration is done through the *Speed Box* (2) located at the left side of the planter ( rear view ). In order to achieve more combinations, you should interchange sprockets "A" ( motor ) and "B" ( moved ).
- 2 - In case you have to interchange the sprockets, check the chain tension. Stretcher (1) is provided with torsion spring for better flexibility.

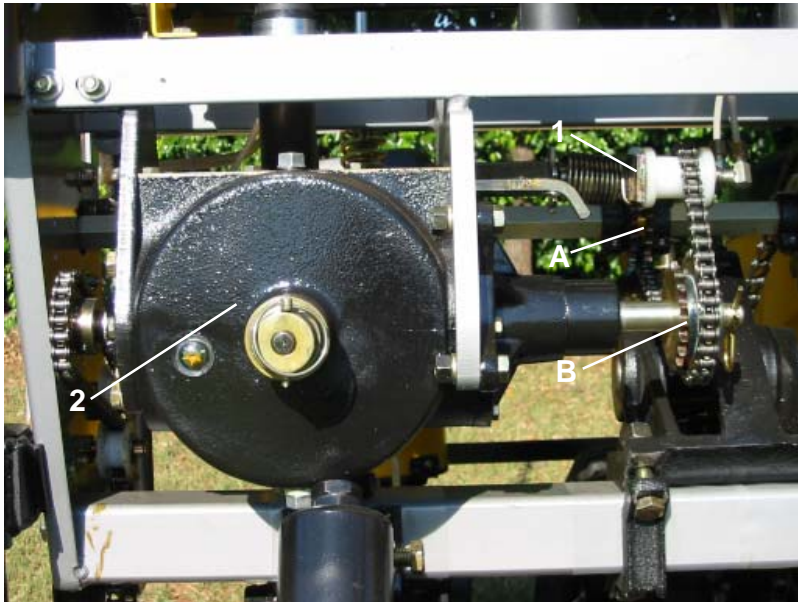


FIGURE 24

## SPEED BOX SYSTEM *Speed Box* (FIGURA 25)

- 1 - 1 - Planter is provided with a Speed Box, that drives a distribution system with simple adjustments ( Tools free ).
- 2 - To calibrate the seed quantity per linear meter, choose the correct seed plate and select the desired combination using the number / letter lever (1). Exemplo: Combination **E 6** - detail **A** on **FIGURE 20**, indicates that the letter lever should be placed on position " E " and the number lever should be on position "6" according to **FIGURE 20**.
- 3 - In order to move levers, remove safety pin (2), pull the handling (3), and find the resired position ( combination ). After placing both levers, push back the handling (3) and lock with safety pin (2).

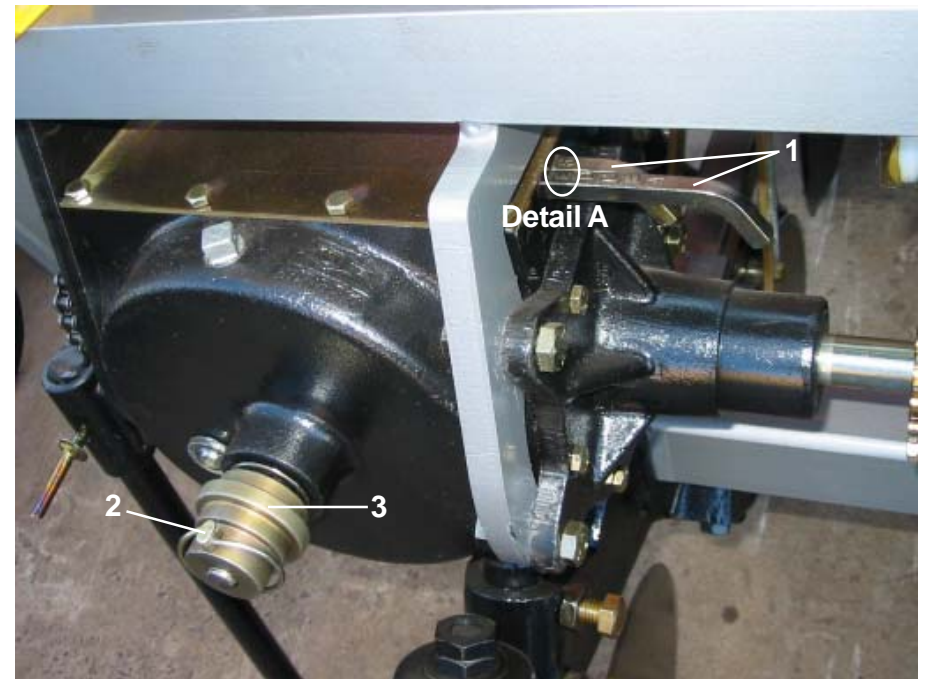


FIGURE 25

FERTILIZER DISTRIBUTION TABLE [ Kg/Ha ]													
Main Shaft Cog		20						Speed Box Cog				31	
Speed Box Combinations	Grams / 50 m	Spacing between Rows [ mm ]											
		400	430	450	500	550	600	650	700	800	900		
F - 1	372	186	173	165	149	135	124	115	106	93	83		
F - 2	419	209	195	186	167	152	140	129	120	105	93		
E - 1	465	233	216	207	186	169	155	143	133	116	103		
F - 3	478	239	223	213	191	174	159	147	137	120	106		
E - 2	523	262	243	233	209	190	174	161	150	131	116		
D - 1	558	279	260	248	223	203	186	172	159	140	124		
F - 4	558	279	260	248	223	203	186	172	159	140	124		
E - 3	598	299	278	266	239	217	199	184	171	150	133		
D - 2	628	314	292	279	251	228	209	193	179	157	140		
C - 1	651	326	303	289	261	237	217	200	186	163	145		
F - 5	670	335	312	298	268	244	223	206	191	167	149		
E - 4	698	349	325	310	279	254	233	215	199	174	155		
D - 3	718	359	334	319	287	261	239	221	205	179	159		
C - 2	733	366	341	326	293	266	244	225	209	183	163		
B - 1	744	372	346	331	298	271	248	229	213	186	165		
A - 1	837	419	389	372	335	304	279	258	239	209	186		
A - 2	942	471	438	419	377	343	314	290	269	236	209		
B - 3	957	478	445	425	383	348	319	294	273	239	213		
C - 4	977	488	454	434	391	355	326	301	279	244	217		
D - 5	1005	502	467	447	402	365	335	309	287	251	223		
E - 6	1047	523	487	465	419	381	349	322	299	262	233		
A - 3	1077	538	501	478	431	391	359	331	308	269	239		
B - 4	1116	558	519	496	447	406	372	344	319	279	248		
C - 5	1172	586	545	521	469	426	391	361	335	293	261		
D - 6	1256	628	584	558	502	457	419	386	359	314	279		
A - 4	1256	628	584	558	502	457	419	386	359	314	279		
B - 5	1340	670	623	595	536	487	447	412	383	335	298		
C - 6	1465	733	682	651	586	533	488	451	419	366	326		
A - 5	1507	754	701	670	603	548	502	464	431	377	335		
B - 6	1675	837	779	744	670	609	558	515	478	419	372		
A - 6	1884	942	876	837	754	685	628	580	538	471	419		

Table 06

FERTILIZER DISTRIBUTION TABLE [ Kg / Ha ]													
Main Shaft Cog		31						Speed Box Cog				20	
Speed Box Combinations	Grams / 50 m	Spacing between rows [ mm ]											
		400	430	450	500	550	600	650	700	800	900		
F - 1	894	447	416	397	358	325	298	275	255	224	199		
F - 2	1006	503	468	447	402	366	335	309	287	251	224		
E - 1	1118	559	520	497	447	406	373	344	319	279	248		
F - 3	1150	575	535	511	460	418	383	354	328	287	255		
E - 2	1257	629	585	559	503	457	419	387	359	314	279		
D - 1	1341	671	624	596	536	488	447	413	383	335	298		
F - 4	1341	671	624	596	536	488	447	413	383	335	298		
E - 3	1437	718	668	639	575	523	479	442	411	359	319		
D - 2	1509	754	702	671	604	549	503	464	431	377	335		
C - 1	1565	782	728	695	626	569	522	481	447	391	348		
F - 5	1609	805	749	715	644	585	536	495	460	402	358		
E - 4	1676	838	780	745	671	610	559	516	479	419	373		
D - 3	1724	862	802	766	690	627	575	531	493	431	383		
C - 2	1760	880	819	782	704	640	587	542	503	440	391		
B - 1	1788	894	832	795	715	650	596	550	511	447	397		
A - 1	2012	1006	936	894	805	732	671	619	575	503	447		
A - 2	2263	1132	1053	1006	905	823	754	696	647	566	503		
B - 3	2299	1150	1069	1022	920	836	766	707	657	575	511		
C - 4	2347	1174	1092	1043	939	853	782	722	671	587	522		
D - 5	2414	1207	1123	1073	966	878	805	743	690	604	536		
E - 6	2515	1257	1170	1118	1006	914	838	774	718	629	559		
A - 3	2587	1293	1203	1150	1035	941	862	796	739	647	575		
B - 4	2682	1341	1248	1192	1073	975	894	825	766	671	596		
C - 5	2816	1408	1310	1252	1127	1024	939	867	805	704	626		
D - 6	3018	1509	1404	1341	1207	1097	1006	928	862	754	671		
A - 4	3018	1509	1404	1341	1207	1097	1006	928	862	754	671		
B - 5	3219	1609	1497	1431	1288	1170	1073	990	920	805	715		
C - 6	3521	1760	1637	1565	1408	1280	1174	1083	1006	880	782		
A - 5	3621	1811	1684	1609	1448	1317	1207	1114	1035	905	805		
B - 6	4023	2012	1871	1788	1609	1463	1341	1238	1150	1006	894		
A - 6	4526	2263	2105	2012	1811	1646	1509	1393	1293	1132	1006		

Table 07

## Practical calculation for fertilizer distribution

Determine spacing between rows and the quantity of fertilizer to be distributed by Ha.

Example: Planter with 0.45m spacing to distribute 500 kg of fertilizer per row, use the following formula:

$$X = \frac{E \times Q}{A} \times D$$

Formula data:

E = Spacing between rows (mm)

Q= Quantity of fertilizer to be distributed

A = Area to be fertilized (m<sup>2</sup>)

D = 50 meter distance (Test)

X = Grams of fertilizer in 50 meters

Solve:

$$X = \frac{450 \times 500}{10.000} \times 50$$

$$X = 22,50 \times 50 = 1125$$

X= 1125 grams in 50 meters per line

## Practical test to check fertilizer and seed distribution quantity.

Check and hold keep planter tyre gauging with 32 lb/inch<sup>2</sup>.

Mark test distance. At the table, we made an option for 50 linear meters. fill planter hoppers at least by the half. Run some meters out of the test area, in order that both seed and fertilizer fill the dispensers.

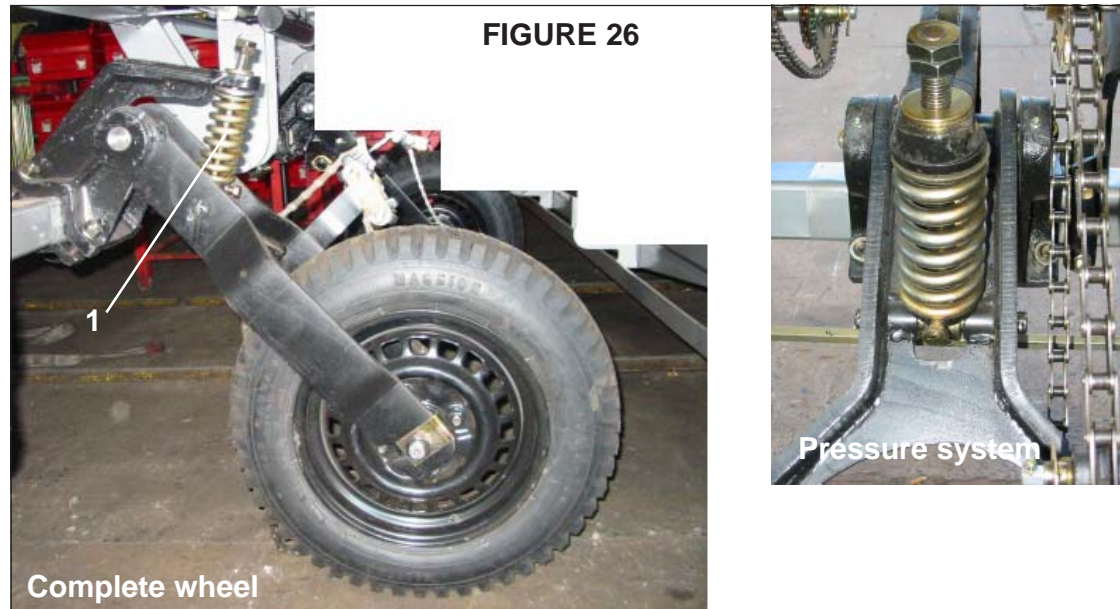
Seal seed tube outlets and place sacks at fertilizer outlets. With tractor in the delimited area, always at the same speed of plantation. After running the delimited space (Fertilizer Table) at the column (grams per line in 50 meters), remove seed tube sealing and collect the same for counting. If necessary, make new tests, changing gears.

## WHEEL ARTICULATION SYSTEM (FIGURE 26)

1 - The wheel articulation system was developed so both wheels can make the transmission and also copy the irregular surface, making sure that seed and fertilizer will be distributed without interruption.

2 - During No-Till, the wheels will work with oscillation. If necessary, add 3/4 of water in each tyre, in order to maintain a regular transmission.

3 - For more adherence, both wheels are equipped with a pressure system (1). Never work without the pressure system.



## OPERATIONS (CHECK LIST)

- 1 - Retighten all bolts and nuts after the first day of work.
- 2 - Always maintain the correct calibration of the tyres. **(32 lbs/pol<sup>2</sup>)**, in order to prevent planting and fertilizing variations.
- 3 - Remember to lubricate all nipples according to this instruction manual.
- 4 - When loading the hoppers, make sure they are completely clean.
- 5 - Notice all seed and fertilizer distribution mechanism and also the initial calibrations before starting to work.
- 6 - Make sure the planter is levelled behind the tractor. The working seed should always remain constant.
- 7 - Check the seed and fertilizer depth. Also check the pressure of the compactation wheels.
- 8 - Check the position of the fertilizer and seed in the furrow.
- 9 - Check the spacing between rows, according to the crop that is being distributed.

## 7 - MAINTENANCE

### TYRE PRESSURE (Figure 27)

- 1 - Tyres must be always correctly gauged, thereby preventing premature wear and tears for excess or lack of pressure.
- 2 - Seed tyre gauging should be 32 lb/inch<sup>2</sup> .

### LUBRICATION

- 1 - Lubrication is indispensable for a good performance and higher durability to moving parts of the machine thereby helping to save maintenance costs
- 2 - Prior to beginning operation, lubricate carefully all grease nipples, always watching relubrication intervals. Certify lubricant quality as to its effectiveness and purity, avoiding use of products contaminated by water, earth and other agents.

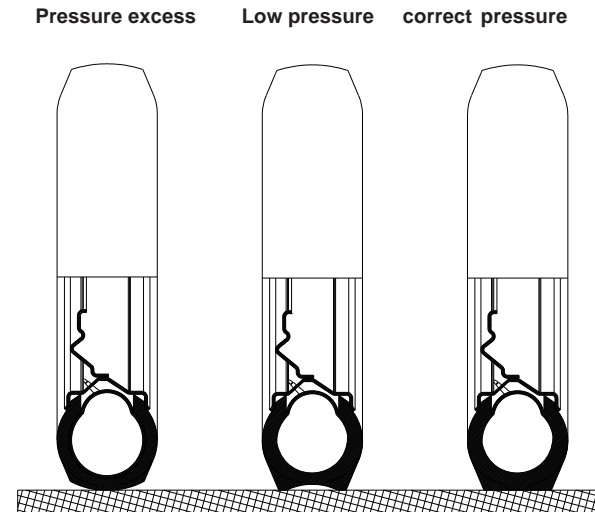


FIGURE 27

### TABLES FOR GREASE AND EQUIVALENTS

MANUFACTURER	TYPE OF GREASE RECOMMENDED
PETROBRÁS	LUBRAX GMA2
ATLANTIC	LITHOLINE MP 2
IPIRANGA	SUPER GRAXA IPIRANGA IPIRANGA SUPER GRAXA 2 ISAFLEX 2
CASTROL	LM 2
MOBIL	MOBILGREASE MP 77
TEXACO	MARFAK MP 2 AGROTEX 2
SHELL	RETINAX A ALVANIA EP2
ESSO	MULTIPURPOSE GREASE H LITHOLINE MP 2
BARDAHL	MAXLUB APG 2EP

If other lubricants and/or equivalent grease brands not included in the table exist, refer to technical manual of the own manufacturer.

Table 7

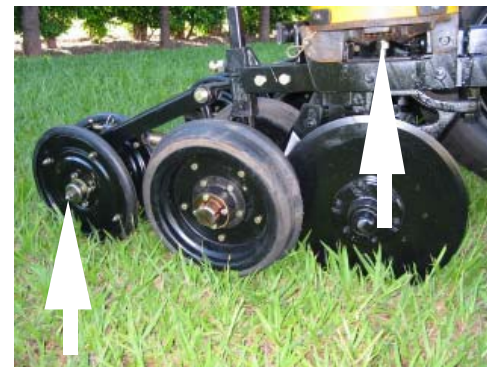
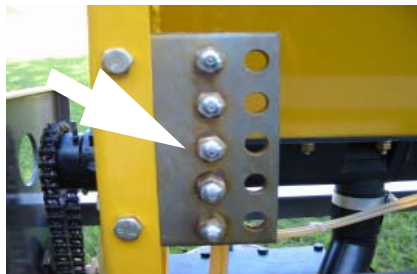
### Centralized lubrication system (Figure 28)

- 1 - Central lubricating system makes maintenance quicker and easier, thereby allowing to lubricate all lateral and central points of machine.
- 2 - Prior to beginning lubrication, clean all grease fittings with a fine thread-free clean cloth, and replace damage ones.
- 3 - Lubricate all nipples of the central system every 10 working hours



FIGURE 28

LUBRICATE AT EVERY 10 WORKING HOURS



**IMPORTANT:** Make sure you do not exceed when greasing the seed distribution base. It can block the seed exit.

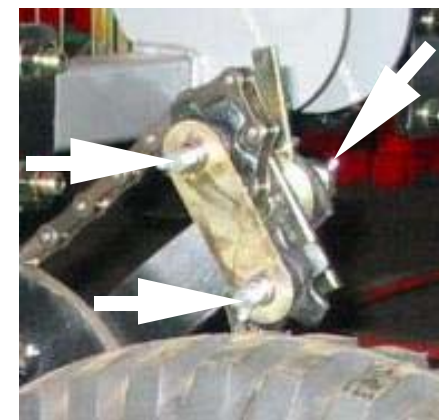
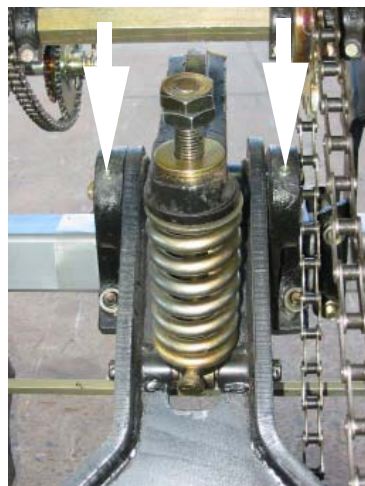
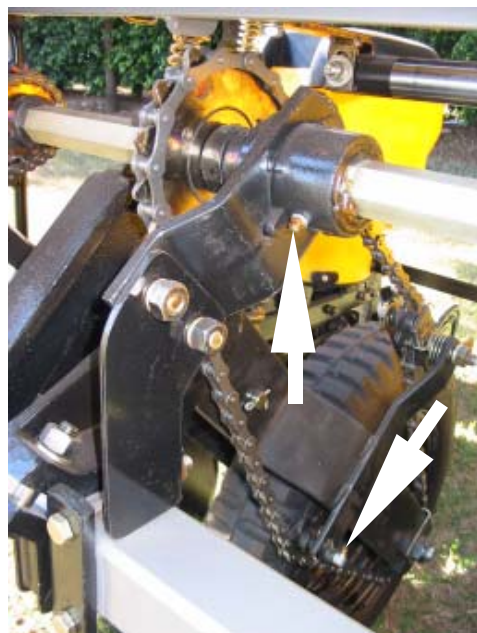


FIGURE 29

## LUBRICATE AT EVERY 60 WORKING HOURS



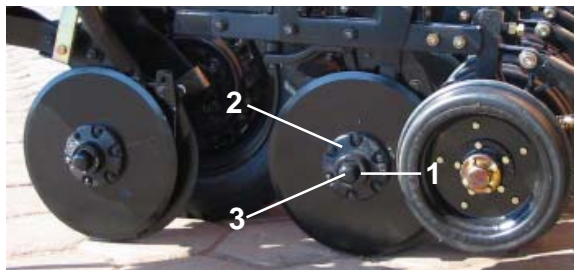
**FIGURE 30**

## LUBRICATE AT EVERY 200 WORKING HOURS (FIGURE 31)

Lubricate double disc hubs and depth control wheels at every 200 working hours.

Proceeding as follows :

- 1 - Remove retaining ring (1) from hub (2)
- 2 - Check the bearings and retighten if necessary, through lock nut.
- 3 - Insert grease inside hub cover (3).
- 4 - Replace hub cover and fix it with retaining ring (1).



**FIGURE 31**

## SPEED BOX (FIGURE 32)

- 1 - Change the Seed Box (1) oil after the first 30 working hours. Then, after every 1500 hours. Always use mineral oil SAE 140 ( total oil capacity storage is 1,8 liters )
- 2 - Check oil level on daily basis. Oil Level can be checked through window (2).
- 3 - Use only original safety lock pin (3) supplied from the factory, due to hardness control.

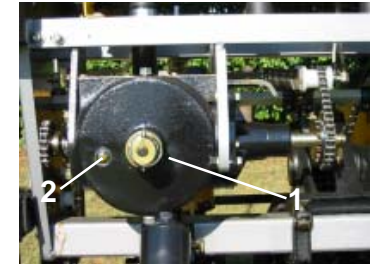


## CHAIN STRETCHER

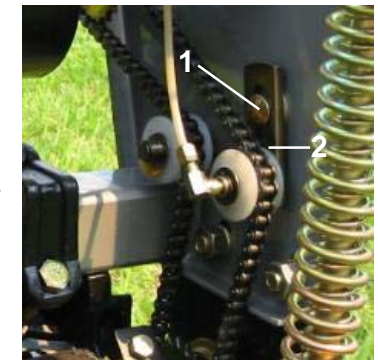
### FIX STRETCHER (FIGURE 33)

- 1 - Check chain tension on daily basis. The normal gap should be  $\pm 1$  cm ( from the center ).
- 2 - In order to stretch the chain, loosen bolt (1) and displace the stretcher (2) until you achieve the desired tension. Retighten the bolt.

**FIGURE 32**

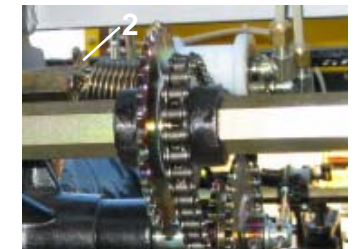


**FIGURE 33**



## OSCILATING STRETCHER(FIGURE 34)

- 1 - Stretcher (1) is composed by a torsion spring with large flexibility. If necessary, you can increase the pressure by stwisting sprocket (2) and lock at the required position.



**FIGURE 34**



OPERATIONAL MAINTENANCE

**Table 09**

PROBLEMS	CAUSES	SOLUTIONS
During operation, fertilizer starts flowing through the safety outlets.	Clogged hoses or pieces of plastics inside the distribution system.	Clean the outlet that is blocked, until fertilizer starts flowing normally through the hose down to the conducting tube.
Fertilizer hub shaft does not rotate.	Coil blocked with wet fertilizer or excessive fertilizer in the closed exit.	Unclog the fertilizer coil. Check if there are any loose chute exits and the fertilizer has entered through the lateral thereof.
Planting units with different depth.	Check if pressure springs and depth control wheels are with the same calibrations.	Calibrate all pressure springs and depth control wheels at the same point.
Furrow is opening too much during operation.	Wet soil sticks to the discs/furrowers and excessive working speed.	Use double discs to fertilize and reduce working speed.
Seed breakage	High working speed. Incorrect plate thickness. Seed plate is not set correct. Seed size is not correct according to plate. Seed with humidity.	Reduce working speed. Use correct seed plate. ( check diameter of holes ) Place the seed plate correctly ( see manual ) Choose another seed size Always use dry seeds
Tractor lifts the front during transport or when planter is liften.	No front weight available on the tractor.	Place front weights to the tractor.
Planter moves to the sides during operations in irregular areas.	Hydraulic arms of the tractor are loose.	Tighten both hydraulic arms and centralize planter behind the tractor.

## 08 - CLEANING

### FERTILIZER SYSTEM (FIGURE 35)

Always clean the fertilizer distribution system after planting operation.

This can be done as follows :

- 1 - Loosen bolt (1), and remove pin (2), loosen nuts (3) and remove hub and sprocket (4). Now you can remove shaft (5). Check all PVC covers and replace them if necessary.
- 2 - Clean all hoppers and shafts, washing with neutral water. Assemble all parts, checking if the PVC covers exits are in the correct position.

**IMPORTANT: After assembling the fertilizer shaft, make sure it turns free. Otherwise check if all parts were assembled correctly. This is very important in order to prevent any kind of breakage to the system.**

### GENERAL CLEANING

- 1 - Remove all transmission chains and keep them on oil until the next planting season.
- 2 - Lubricate the planter completely.
- 3 - Check if all moving parts are OK. or need to be replaced.

### SEED DISTRIBUTION SYSTEM

After planting operation is finished, we recommend you to empty all hoppers and clean the distribution system ( on daily basis ).

Also check all distribution moving parts and replace if necessary. This is very important in order to maintain the seed distribution precision.

**IMPORTANT : In case you have to use chemical products for seed treatment, we recommend you clean the system twice a day, or at every reload.**

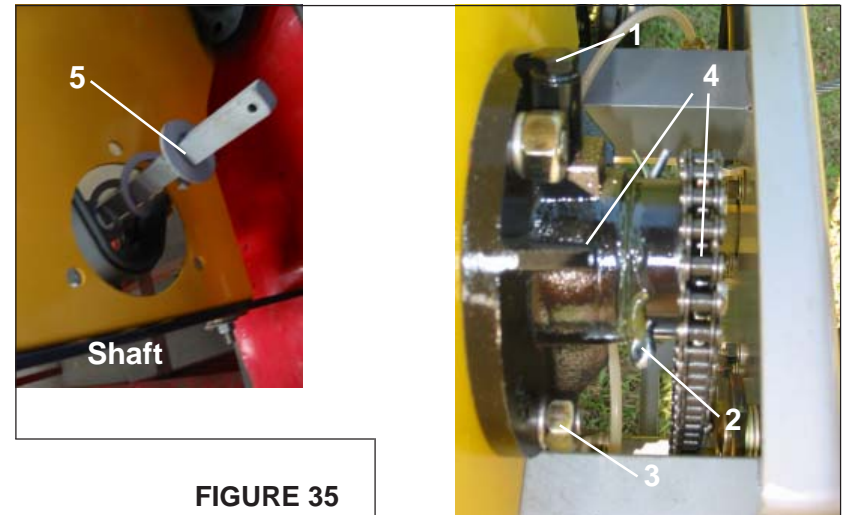


FIGURE 35

- o. Use Baldan original parts.

- 4 - After all cleaning procedures are done, park your planter under roof. We recommend you lower the cutting coulters and double discs on top of wooden basis.
- 5 - Wash and clean the planter before starting your next planting season.



**IMPORTANT: Do not use chemical products to wash the planter. It can damage the original paint.**

## **7 - PREPARING THE TRACTOR**

For a perfect planting operation, make a general check-up on your tractor.

Check tyre pressure according to manufacturer recommendations. fill in rear tyres with water ( 75% ).

When working with mounted planters ( SP light ) check if front weights are on the tractor. ( 120 - 150Kg ). The weights will change according to the tractor that is being used.

Adjust the distance between the front tyres of the tractor, according to the table below

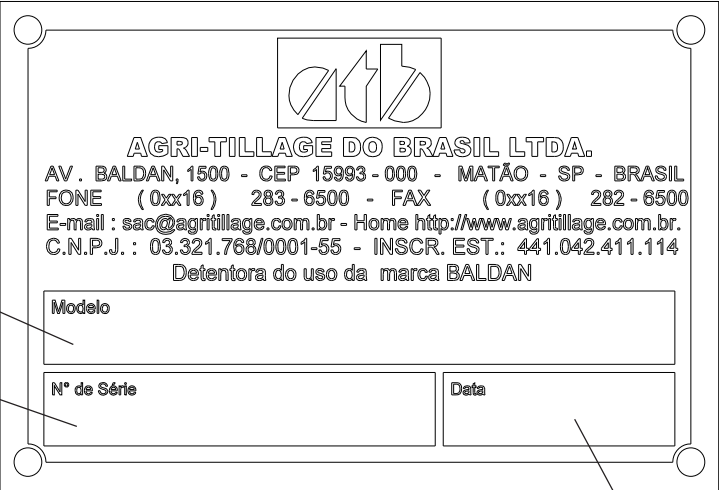
## **8 - RESUME OF THE OPERATION ADJUSTMENTS**

- 1 - Lubrication;
- 2 - Hitching to the tractor;
- 3 - Row marker;
- 4 - spacing between rows;
- 5 - Seed distribution;
- 6 - Fertilizer distribution;
- 7 - Practical seed/fertilizer distribution test;
- 8 - Fertilizer position and depth;
- 9 - Furrow opening and seed depth control;
- 10 - Cutting coulter;
- 11 - Covering and compactation;
- 12 - Operations - Important points.

**9 - IDENTIFICATION CPT:SPLIGHT05417**

1 - In order to refer to part catalogs or apply for Baldan technical assistance, always indicate model (1), serial number (2) and date (3) of manufacture located on the identification tag (4).

2 - ALWAYS REQUIRE BALDAN ORIGINAL PARTS.



**FIGURE 36**

Fill in the following data for having always the correct information regarding your planter's warranty.

Owner: \_\_\_\_\_

Dealer: \_\_\_\_\_

Farm: \_\_\_\_\_

City: \_\_\_\_\_ State: \_\_\_\_\_

Warranty Certificate Number: \_\_\_\_\_

Model: \_\_\_\_\_

Serial number: \_\_\_\_\_

Date of purchase: \_\_\_\_\_

Invoice No.: \_\_\_\_\_

Remarks: \_\_\_\_\_

\_\_\_\_\_  
\_\_\_\_\_  
\_\_\_\_\_  
\_\_\_\_\_  
\_\_\_\_\_  
\_\_\_\_\_

