

SPD *Speed Box*

No-Till Seed Drill

Series 3000 / 4000 / 5000



Instruction Manual



www.baldan.com.br

PRESENTATION

We appreciate your purchase and congratulate you for the excellent choice you just made because you have purchased a product manufactured with technology from **BALDAN IMPLEMENTOS AGRÍCOLAS S/A.**

This instruction manual will guide you through the procedures that are necessary since its acquisition up to the operating procedures of use, security and maintenance.

BALDAN ensures that has delivered this farming implement to the dealer in perfect conditions.

The dealer is responsible for the custody and maintenance of this farming implement and also for the assemblage, retightening, lubrication and overhaul.

In the technical delivery, the dealer must advise the user on its maintenance, security, its obligations under any technical assistance, the strict observance of the guarantee and reading of the instruction manual.

Any request for technical assistance under warranty should be made to the dealer where it was purchased.

We reiterate the need for careful reading of the **Warranty Certificate** and observance of all items in this instruction manual, as doing so, the useful life of your farming implement will increase.



Instruction Manual



INDEX

Safety rules	6	<i>Adjustment of the fine seed hopper (optional)</i>	44
Components	11	<i>Independent system</i>	45
Technical specifications	12	Fertilizer distribution system	45 - 48
Mounting	13	Practical calculation for seed and fertilizer distribution	49
<i>Coupling header</i>	13	<i>Practical test to check the quantity of fertilizer and seed distribution</i>	49
<i>Mounting of compaction wheels</i>	13	<i>Adjustment of row markers</i>	50
<i>Mounting of the optional fine seed hopper</i>	14	<i>Adjustment of row marker disc</i>	50
<i>Assembling the rows markers- optional</i>	15	<i>Pressure of the springs</i>	51
<i>Mounting of the mechanical kit for side transport - optional</i>	16	Depth adjustment	51 - 55
<i>Mounting of the hydraulic kit for side transport - optional</i>	17	<i>Finisher system</i>	56
<i>For seed drills sold with conventional header</i>	17	<i>Fixation and joint system of the wheels</i>	57
<i>Front frame</i>	17	<i>Single seed hopper</i>	57
<i>Rod coupler</i>	18	No-till kit (cpd) - optional	58
<i>Header stabilizing bar</i>	18	<i>Cpd mounting - no-till kit (cpd) - optional</i>	59
<i>Wheelset for transport (front side of frame)</i>	19	<i>Cpd kit seed adjustment</i>	60
<i>Wheelset for transport (rear side of frame)</i>	20	<i>Adjustment of the cpd seed distribution system</i>	61
<i>Side frame</i>	21	<i>Seed distribution discs for cpd kit for each crop</i>	62
<i>Opening piston and lock bar of header</i>	21	<i>Cpd seed depth control wheel adjustment</i>	63
<i>Coupling header</i>	21	<i>Adjustment of "v" compaction wheels</i>	64
<i>Electrical system</i>	22	<i>Adjustment of the double disc cleaners</i>	65
<i>Connection of the control panel</i>	23	<i>Position of the furrower</i>	65
Preparation of the seed drill for transport	24 - 25	<i>Opening of the furrow and position of the fertilizer in the soil</i>	65
Header opening operation for work	26 - 30	Maintenance	66
Closing of the header	30	<i>Tire pressure</i>	66
<i>Lubricate every 60 hours of work</i>	36	<i>Lubrication</i>	66 - 68
Lubrication (side transport spd - 5000)	36	Operating maintenance	69
<i>Lubricate every 200 hours of work</i>	36	Optional equipments	70
Coupling to the tractor	37 - 39	Mixer set	71
Operation	39 - 42	<i>Hectare counter - location and mounting</i>	72
<i>Spacing between rows</i>	40	<i>How to calculate the planted area</i>	72
<i>Table of maximum spacings</i>	40	Cleaning	73
<i>Position of rows on the frame</i>	40	<i>Fertilizer system</i>	73
<i>New spacings</i>	41	<i>Seed System</i>	73
<i>Seed adjustment</i>	42	<i>Cpd seed system cleaning</i>	74
Seed rate configurations	42	<i>General cleaning</i>	74
<i>Table of seed quantity</i>	42	Operations	74
<i>Approximate seed distribution table</i>	43	Identification	75

01

SAFETY RULES

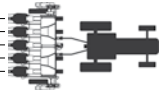

THIS ALERT SYMBOL INDICATES IMPORTANT SAFETY NOTES. WHENEVER YOU FIND IT IN THIS MANUAL, READ THE MESSAGE WITH ATTENTION TO AVOID ANY ACCIDENT.

 **ATTENTION**

- Read the instruction manual carefully, so you can learn the recommended safety practices.

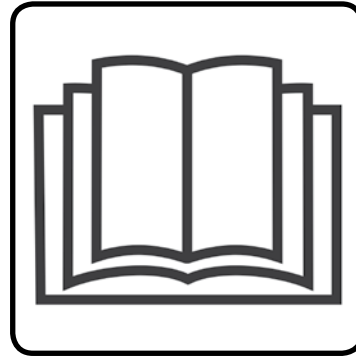
 **ATTENTION**

- Do not operate the tractor if the front is light. With a tendency to rise, add weights on the front of the tractor or front wheels.

 **ATTENTION**

- Only begin operating the tractor when are properly accommodated and with the seat belt fastened.

 **ATTENTION**

- There are risks of serious injury by tumbling when working on slopes.
- Do not use excessive speed.



ATTENTION

- Do not work the equipment if the gears protection wasn't properly placed.
- Just take off the protections to proceed gears change, replace it immediately.
- To do any service on gears machine, disable the turnstiles.
- Do not do any regulations with the equipment working.

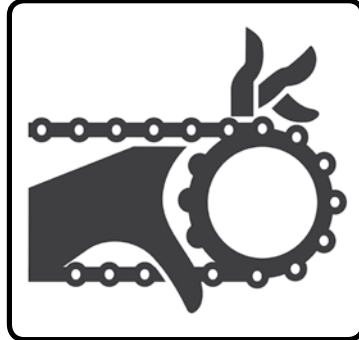

ATTENTION

- When looking for a possible leak in the hoses, use a piece of cardboard or wood, never use your hands.
- Avoid the incision of fluid in the skin.

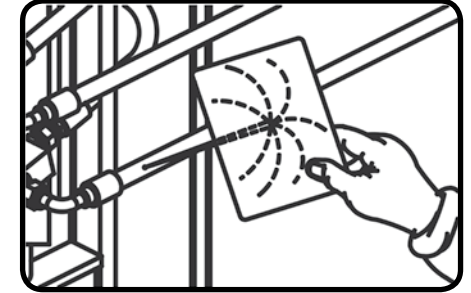

ATTENTION

- Keeps far from active elements (Discs),
- They are sharp and can cause injury.
- To proceed any service on discs use safety gloves.



ATTENTION

- Before performing any maintenance on your equipment, make sure it is turned off. Avoid getting hit.

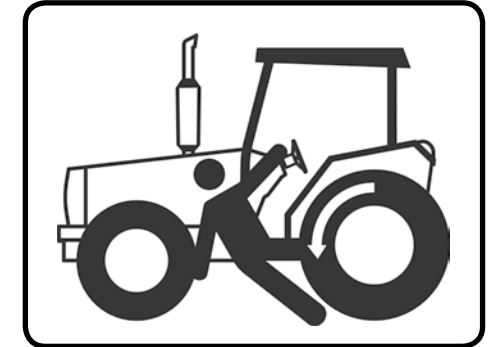

ALCOHOL OR DRUGS CAN GENERATE SOME LOSS OF REFLEXES AND CHANGE THE OPERATOR'S PHYSICAL CONDITIONS. SO, NEVER OPERATE THIS EQUIPMENT UNDER USE OF THESE SUBSTANCES.

! ATTENTION

- The hydraulic oil works under pressure and can cause serious injury, if has any leak. always check the hoses condition. If has any leakage replace it.
- Before connect and disconnect the hydraulic hoses release the pressure.

**! ATTENTION**

- Avoid accidents caused by intermittent action of rows mark
- Make sure if has anybody closer to the row mark.

**! ATTENTION**

- It's forbidden operate the equipment if has people over it.
- Do not stay over the platform with the equipment moving.

**! ATTENTION**

- Whenever the seed machine is being operated, watch out for surrounding people.
- Never stay over a platform with the machine in movement.



ALCOHOL OR DRUGS CAN GENERATE SOME LOSS OF REFLEXES AND CHANGE THE OPERATOR'S PHYSICAL CONDITIONS. SO, NEVER OPERATE THIS EQUIPMENT UNDER USE OF THESE SUBSTANCES.

ATTENTION



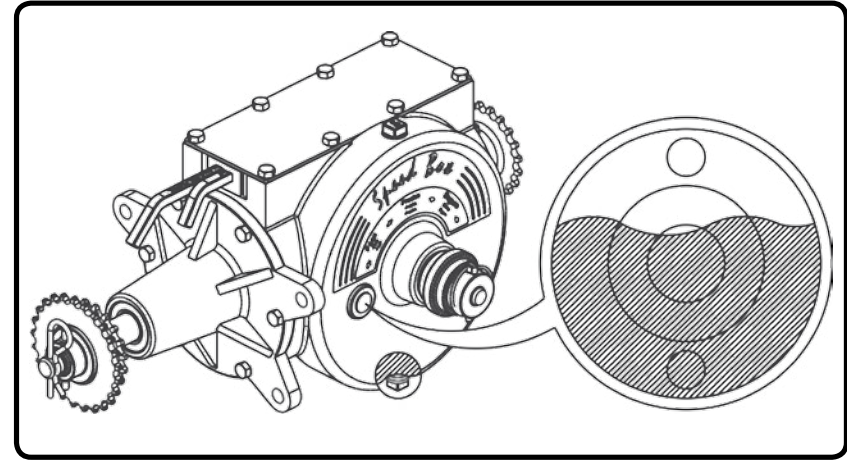













- *Check the oil level daily.*
- *Replace the oil in the gearbox (Speed Box) after the first 30 hours of work, then every 1500 hours, always using ISO VG 150 mineral oil at 40°C (amount of oil used 1.8 liters).*
- *Use only factory original fuse, because only this one has controlled hardness.*



ALCOHOL OR DRUGS CAN GENERATE SOME LOSS OF REFLEXES AND CHANGE THE OPERATOR'S PHYSICAL CONDITIONS. SO, NEVER OPERATE THIS EQUIPMENT UNDER USE OF THESE SUBSTANCES.



THE INCORRECT HANDLING OF THIS EQUIPMENT CAN RESULT IN SERIOUS OR FATAL ACCIDENTS. BEFORE USING THE IMPLEMENT, READ CAREFULLY THE INSTRUCTION OF THIS MANUAL. BE SURE THAT THE PERSON RESPONSIBLE FOR THE OPERATION IS INSTRUCTED ABOUT THE CORRECT HANDLING, SAFETY AND IF READ AND UNDERSTOOD THE INSTRUCTION MANUAL CONCERNING THIS MACHINE.

- 01-  When operating the equipment, prevent people from staying too close to or over the equipment.
- 02-  Use safety gloves on your hands when performing mounting and dismounting services on the discs.
- 03-  Before connecting or disconnecting the hydraulic hoses, release the pressure of the system, activating the control with the tractor switched off.
- 04-  Periodically check the state of conservation of the hoses. Immediately replace the hose in the case of leaks because the oil operates at high pressure and can cause serious injuries.
- 05-  Do not use loose clothing as it can get caught on the equipment.
- 06-  When activating the tractor engine, be properly seated on the operator seat and conscious of the complete knowledge of the correct and safe handling of the tractor as well as the equipment. Always put the brake handle in neutral position, switch off the power control and put the hydraulic controls in neutral position.
- 07-  Do not start the engine in a closed setting without suitable ventilation because the exhaust gases are dangerous to health.
- 08-  When maneuvering the tractor to the coupler of the equipment, make sure there are enough space and no one close to it, always maneuver in reduced speed and be prepared to brake in an emergency.
- 09-  Do not make adjustments with the equipment in operation.
- 10-  When working on inclined lands, proceed carefully, always maintaining the necessary stability. In the case of misbalance, reduce the speed, and turn the wheels of the tractor towards the slope side of the land.
- 11-  Always drive the tractor at speeds compatible with the safety, especially in works on uneven lands or slopes, always keep the tractor coupled.
- 12-  When driving the tractor on roads, keep the brake pedals interconnected and use the safety sign.
- 13-  Do not work with the tractor if the front is light. Add weights to the front or front wheels in case it may be raised.
- 14-  When leaving the tractor, put the brake handle in the neutral position and use the parking brake.
- 15-  Alcoholic beverages and some medications can cause loss of reflexes and change the operator's physical conditions. Therefore, never operate this equipment under the influence of these substances.
- 16-  Read or explain all the procedures above to the operator who cannot read.

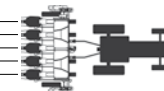

SPD NO-TILL SEED DRILL SPEED BOX 3000 / 4000 / 5000

Figure 1

- 1- Frame
- 2- Row drive piston
- 3- Parking support
- 4- Beater
- 5- Flow divider valve
- 6- Wheel drive piston
- 7- Fertilizer and seed hopper
- 8- Drive shaft of the rows
- 9- Rear platform
- 10- Transmission system
- 11- Wheelset
- 12- Spring rod
- 13- Complete row
- 14- Header adjuster
- 15- Coupling header
- 16- Coupling shackle
- 17- Hydraulic hoses
- 18- Hose support
- 19- Manual Container and Catalogue
- 20- Fertilizer hopper cover
- 21- Small hopper cover

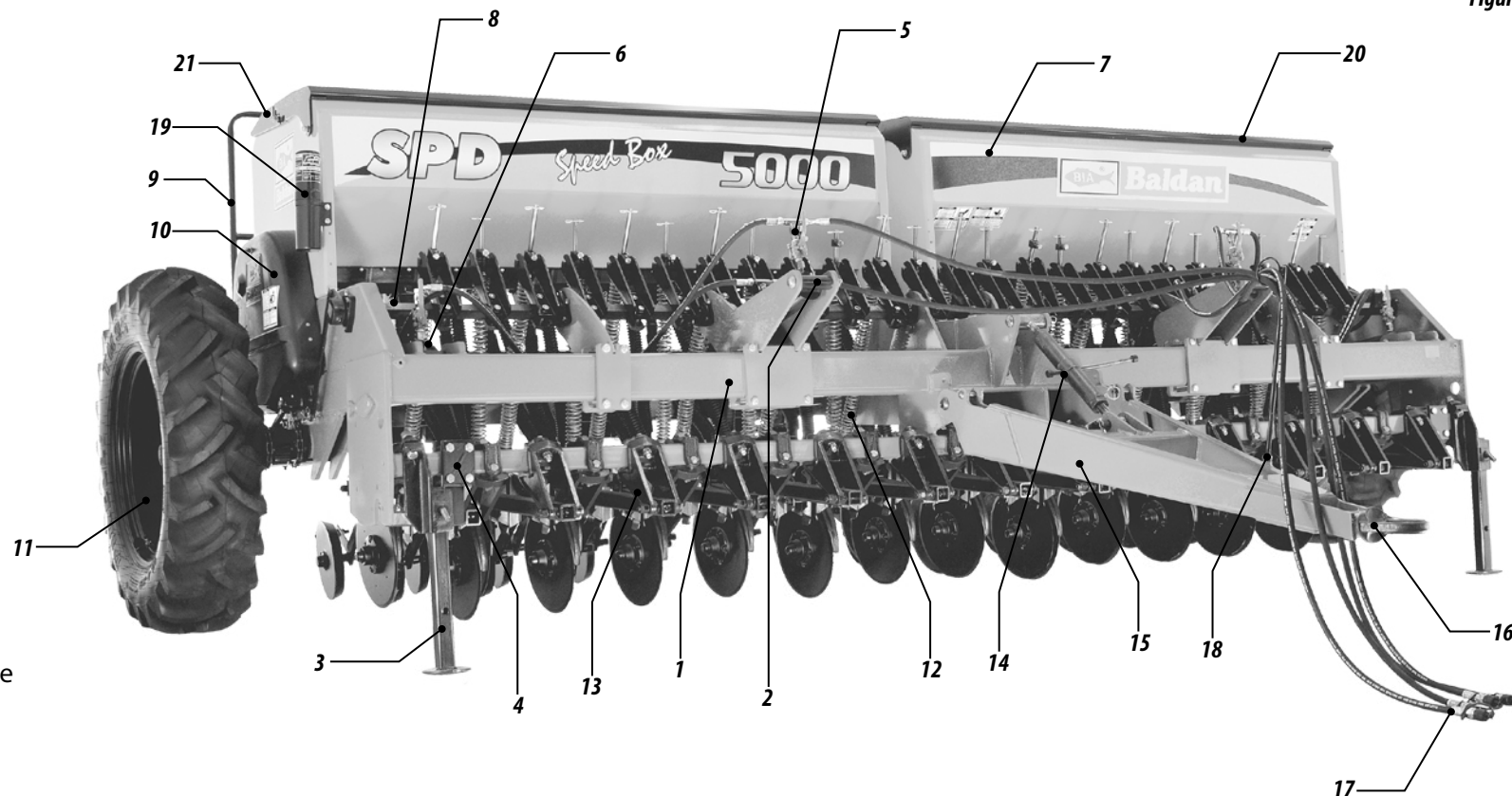

03 TECHNICAL SPECIFICATIONS

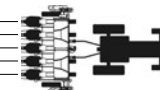
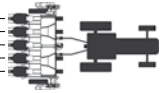

Table 1

Model	Nr of rows	Useful width (mm)	Working width (mm)	Total Width (mm)	Hopper Capacity for:			Approximate weight (Kg)	Approximate tractor power (Hp)	Maximum spacing between rows (mm)	Nr. of Wheels	Number of counterweights	Average yield (Ha/Day)
					Fertilizer (Lt)	Seed (Lt)	Fine Seed (Lt)						
3000	16	2910	3104	4210	620	580	100	3401	75 - 95	194	2	16	18
4000	20	3590	3778	4890	710	660	124	3812	95 - 110	188	2	20	23
5000	24	4270	4455	5570	810	740	140	4223	115 - 130	185	2	24	28

- Minimum spacing between rows 170mm
- Working depth 0 to 120 mm
- Double disc diameter 15"
- Total height 1850 mm
- Total length 3600 mm
- Quantity of water in tires 120 Liters

The BALDAN reserves the right to change specifications of this product without notice.
 The technical specifications are approximate and reported in normal working conditions.



- The seed drills leave the factory semi-mounted, remaining only the mounting of some components. It should be mounted as indicated below:

COUPLING HEADER

- Return the header (1) to the working position by removing the latch and pin (2) that were placed for transport.
- Insert the adjuster (3) into the header fixing with the pin and latch (4), in the arm of the frame with the pin and latch (5).

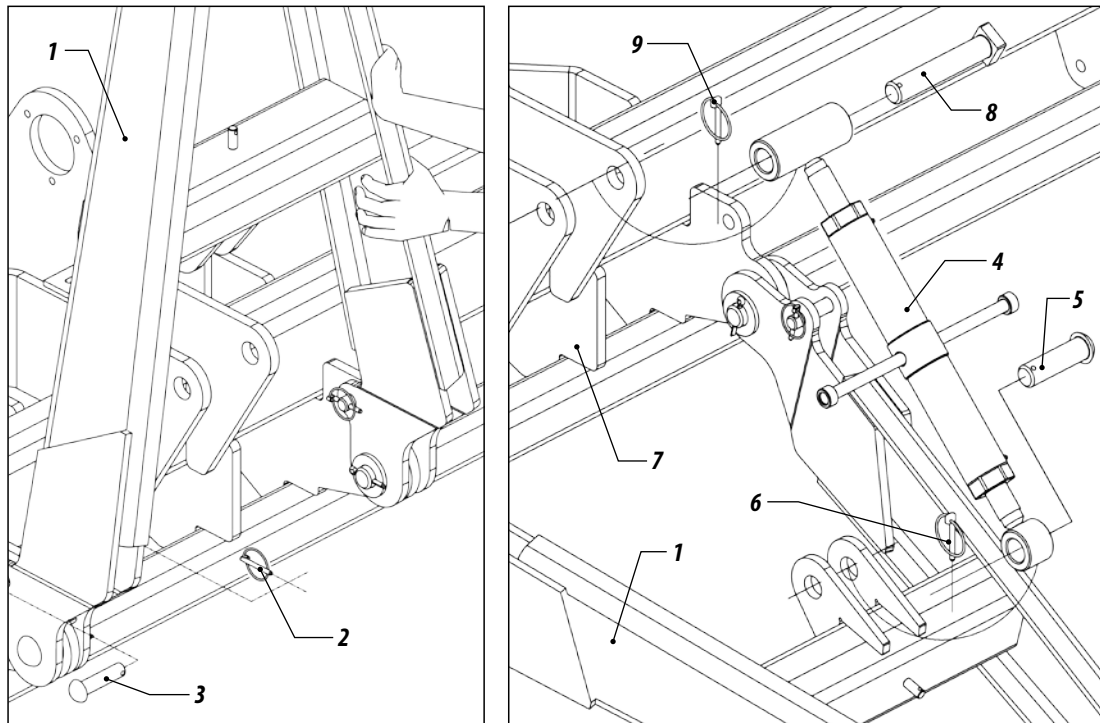

Figures 2

MOUNTING OF COMPACTION WHEELS

- Insert the spring (1) into the rear bracket of the row (2), inset the complete wheel in "V" (3) in the same by attaching the screw, spacer bushing, a bushing on each side, washer and nut (4).
- Pull the pin (5) back and insert the latch (6) to tighten the wheel.

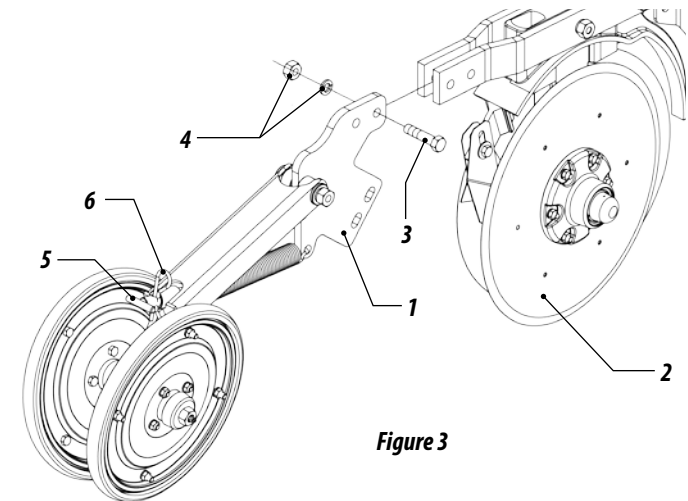

Figure 3

IMPORTANT

Make the assembly process up to the other rows.

! ATENTION

After mounting, perform a general revision on the seed drill to check for objects (nuts, screws or others) inside the hoppers. Retighten all screws and nuts, check all pins, retaining pins and latches, and revise all hoses.

MOUNTING OF THE OPTIONAL FINE SEED HOPPER

- 05 - Attach the fine seed hopper (1) to the back part of the hopper (2) with the screws (3), washers and nuts (4).
- 06 - Insert the separator (5) into the seed gear hub (6), the gear (7) fixing it with screw (8), washers and nuts (9).
- 07 - Put the chain (10) between the gears of the fine seed hopper and the seed shaft, tighten the belt through the stretcher (11).
- 08 - Pass the hose (12) through the cup (13).

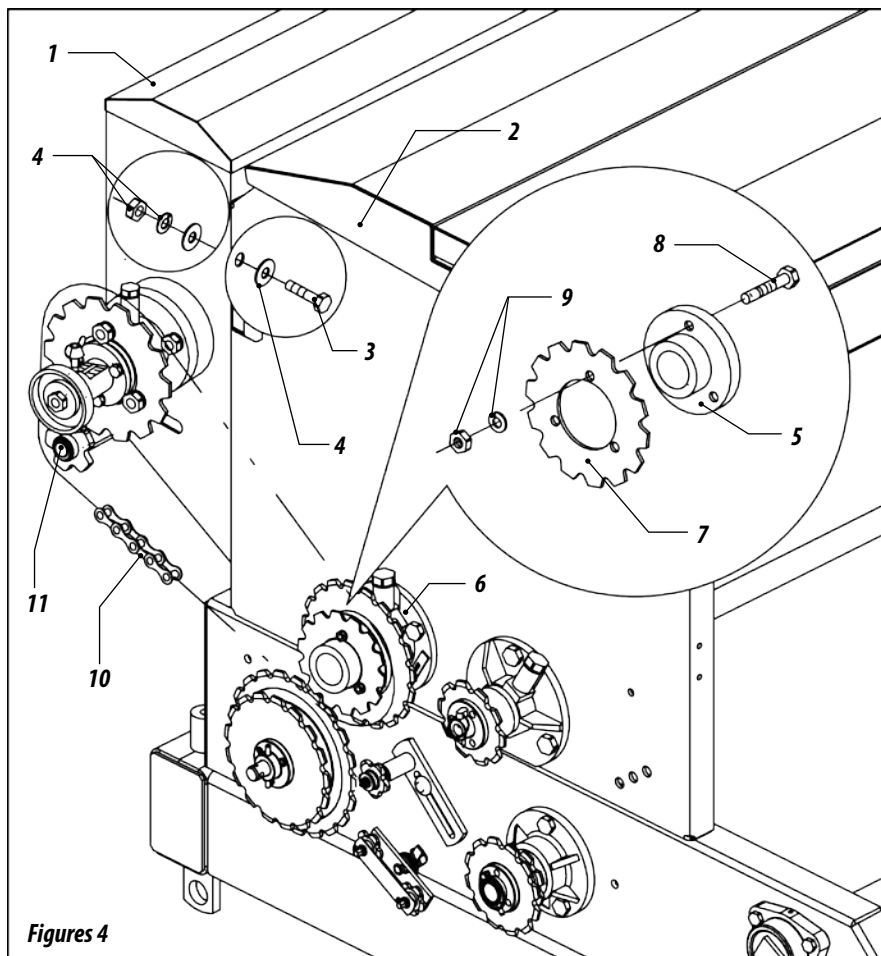

Figures 4

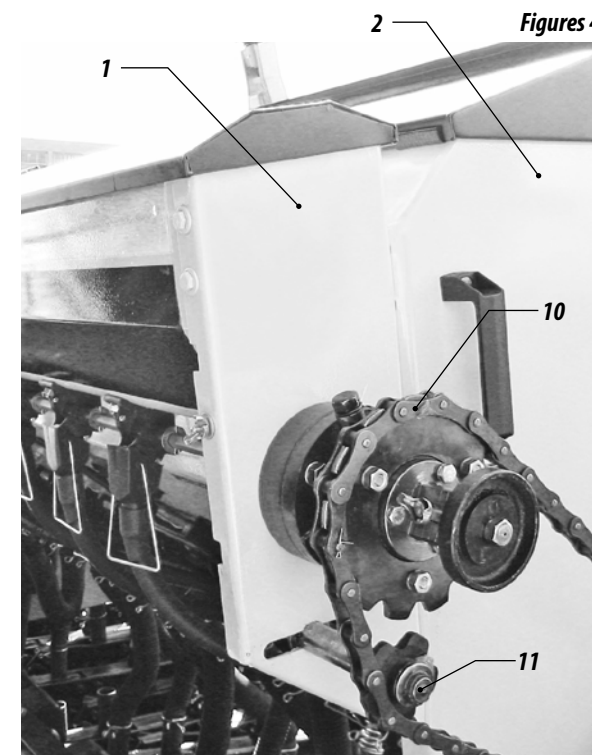
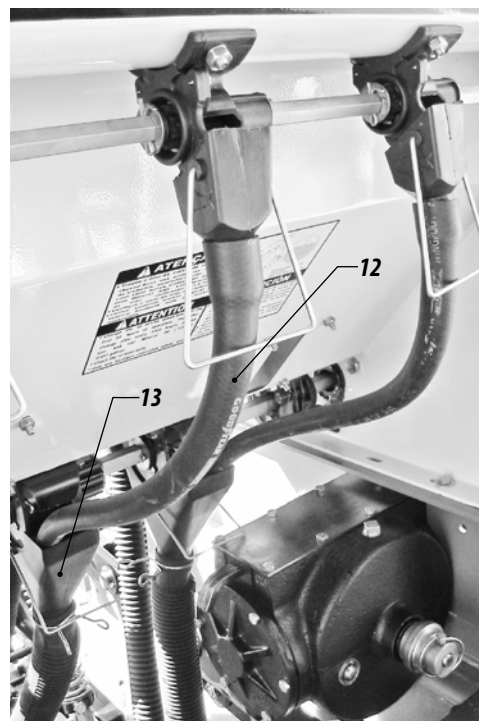

Figures 4

⚠ ATENTTION

After mounting, perform a general revision on the seed drill to check for objects (nuts, screws or others) inside the hoppers. Retighten all screws and nuts, check all pins, retaining pins and latches, and revise all hoses.

ASSEMBLING THE ROWS MARKERS- OPTIONAL

• For assembling the row marker front, proceed as follows:

09- Fix the support (1) in the main frame (2) by screws (3), washers and nuts (4).

10- Then fix the base (5) in the support (1) by bush (6), screws (7), washers and nut (8).

11- After, insert the bar (9) in the base (5) fixing with screws (10).

12- Fix the cylinder (11) in the base (5), by pin (12), washer and split pin (13) and the shank of the cylinder with (14), washer and lock (15).

13- Finally, fix the chain (16) by washer and screws (17).

Figure 5

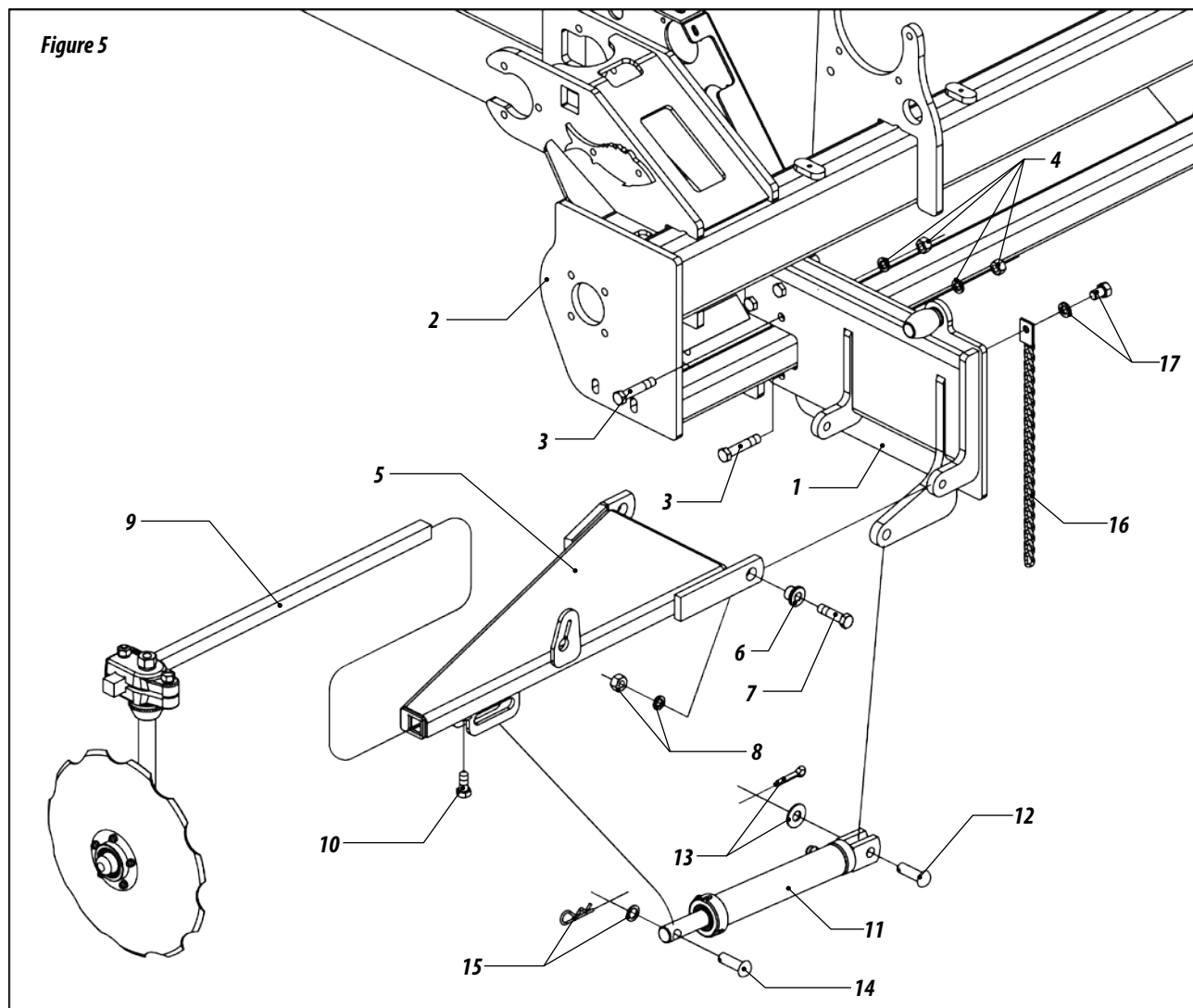

ATTENTION

After end the assembly process with front right row marker, repeat it for assembly the front left row marker.

MOUNTING OF THE MECHANICAL KIT FOR SIDE TRANSPORT - OPTIONAL

• For models SPD 3000 and 4000:

14- Remove the nuts (1) of the wheel (2), place the coupling flange (3) and replace the nuts (1), retightening them.

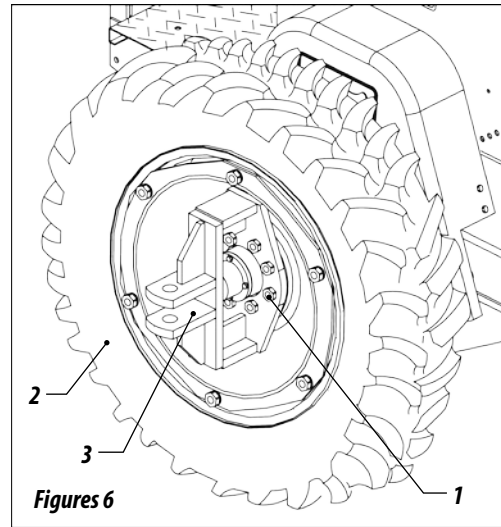

15- Place the coupling header for side transport (4) in the flange (3) through the pin (5).

16- Couple the lower arm of the tractor to the bracket pin "A" of the header.

17- Couple the 3rd point of the tractor to bracket "B" of the header.

18- Lastly, with the aid of the "D" height adjustment handle, couple the lower right arm of the tractor to pin "C" of the header.

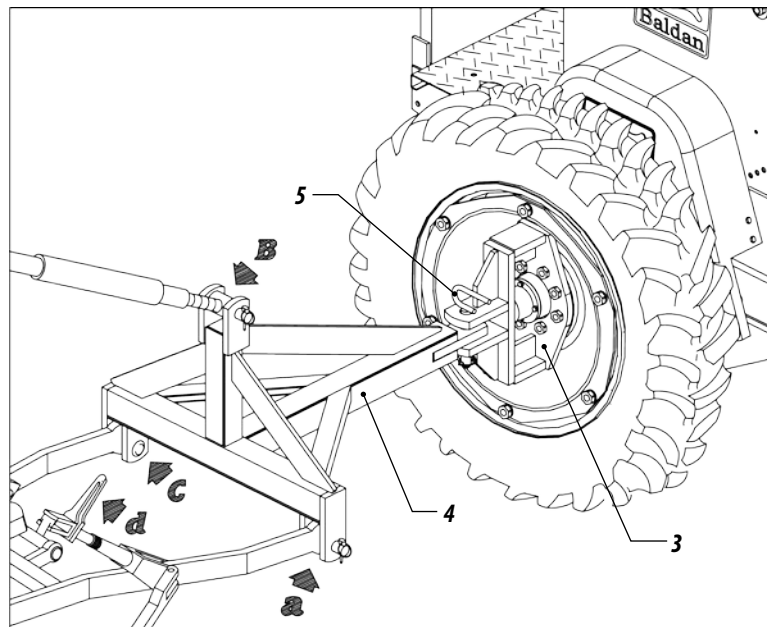

19- Raise the seed drill onto the hydraulic of the tractor and couple the tires (6) through the pins (7).

! ATENTION

Pour baisser ou élever le support de transport lateral (20), élever le semoir en utilisant l'hydraulique du tracteur.

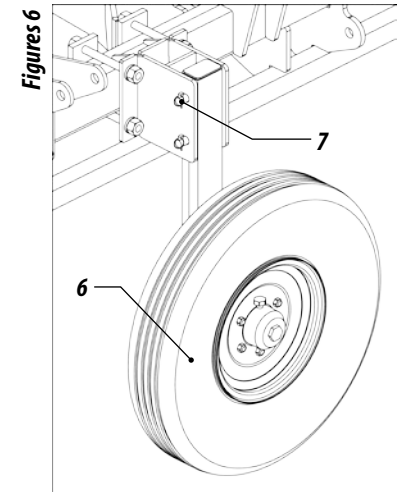

20- After coupling the tires, raise the work header (8), latching it with the pin (9) for side transport of the equipment.

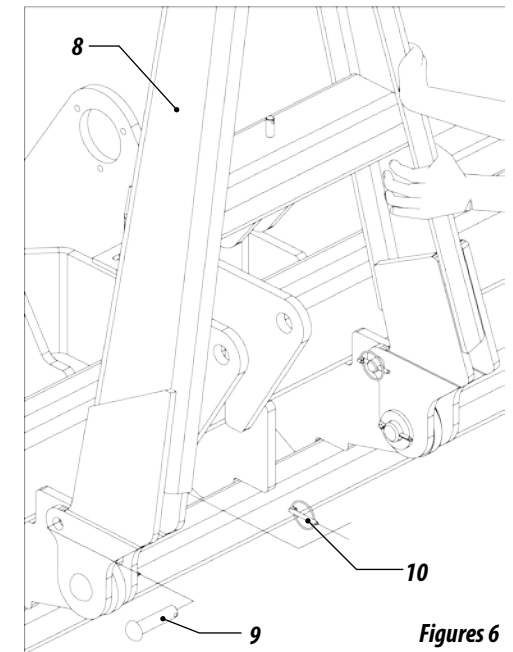

MOUNTING OF THE HYDRAULIC KIT FOR SIDE TRANSPORT - OPTIONAL

- For model SPD 5000:
- The Kits with the Side Transport System with Hydraulic Coupling leaves the factory semi-mounted, remaining only the mounting of some components. It should be mounted as indicated below:

FOR SEED DRILLS SOLD WITH CONVENTIONAL HEADER

- 21 - Remove the coupling header (1) through pins (2) and (3), releasing the latches (4), then remove the adjuster (5). Completely releasing the front of the equip-

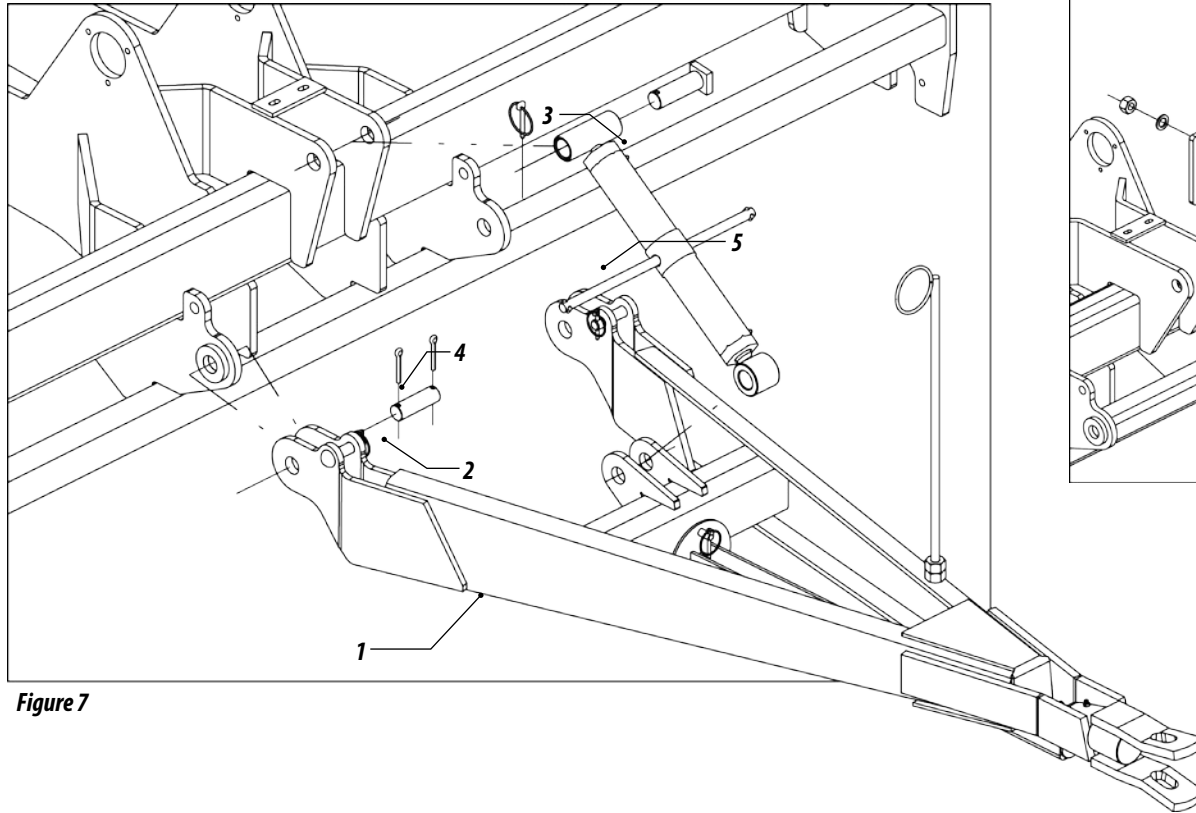

Figure 7

ment for coupling of the head for transport and work (FIGURE 7).

FRONT FRAME

- 22 - Attach the header support (6) to the frame of the equipment through screws (7), nuts and washers (8), according to detail "A", FIGURE 8.

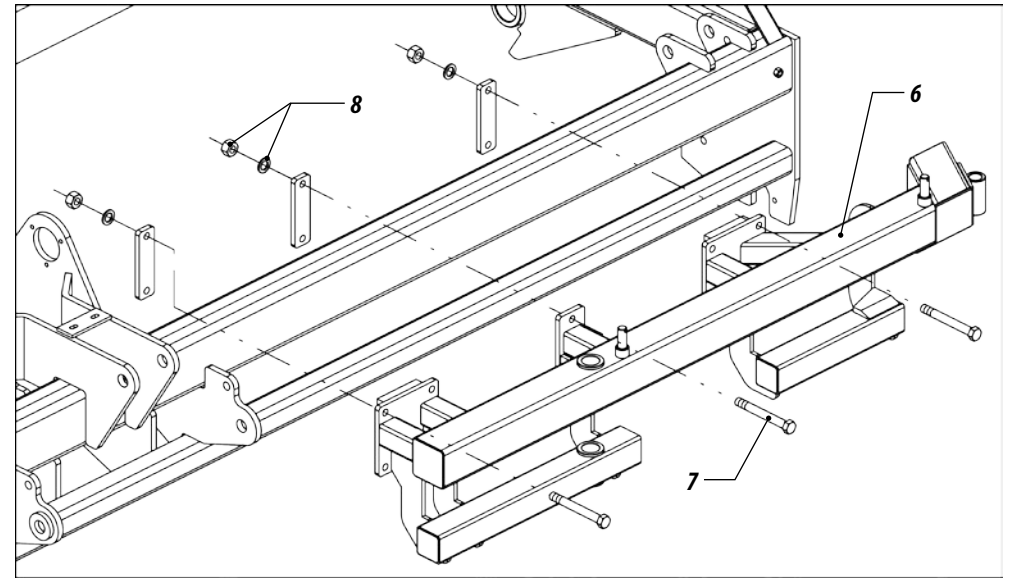
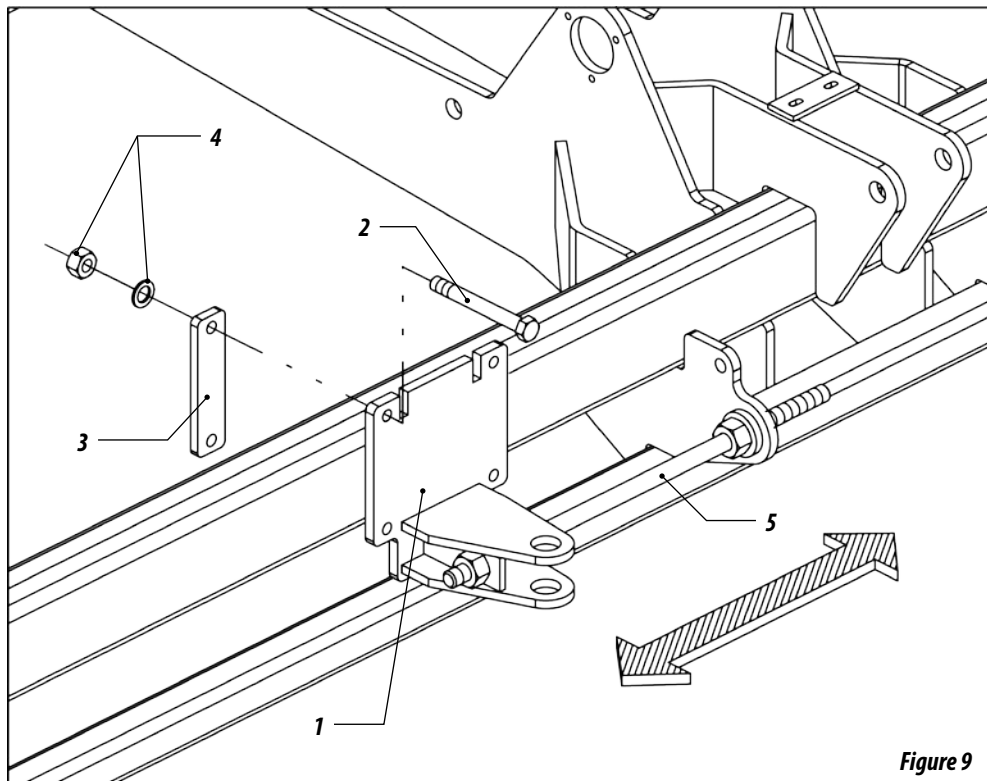

Figure 8

ROD COUPLER

- 23 - Attach the rod coupler (1) through the screws (2), plate (3), washers and nuts (4). Do not tighten the screws (2) in order for the coupler (1) to slide up to the desired position. For this place the rod (5) between the holes of the brackets. After adjusting the distance, tighten the screws (2) figure 09.

**HEADER STABILIZING BAR**

- 24 - With the coupler attached and the rod nuts loose, turn the rod until opens up to insert the header stabilizer bar (6), attaching it on one side with screw (7), washer and nut (8) and on the other side with the rod screw (9) figure 10.

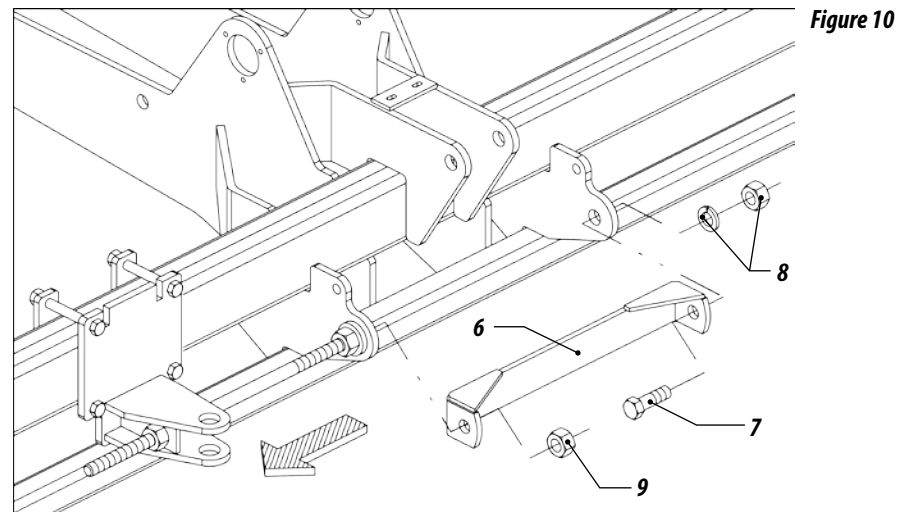

- 25 - After inserting the stabilizer bar, adjust the rod into the position of alignment and lock with the counterweights (10) figure 11.

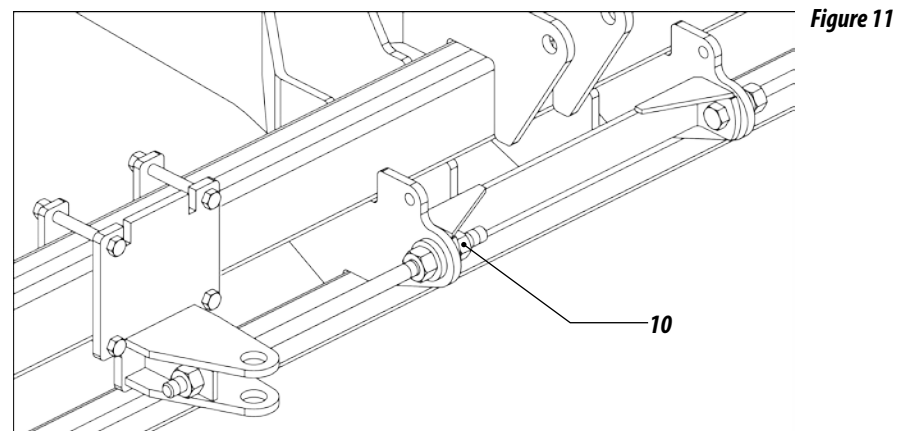

WHEELSET FOR TRANSPORT (FRONT SIDE OF FRAME)

26- To mount the wheelset for transportation, proceed as follows:

27- Attach the wheelset bracket (1) to the seed drill frame through screws (2), nuts and washers (3), figure 12.

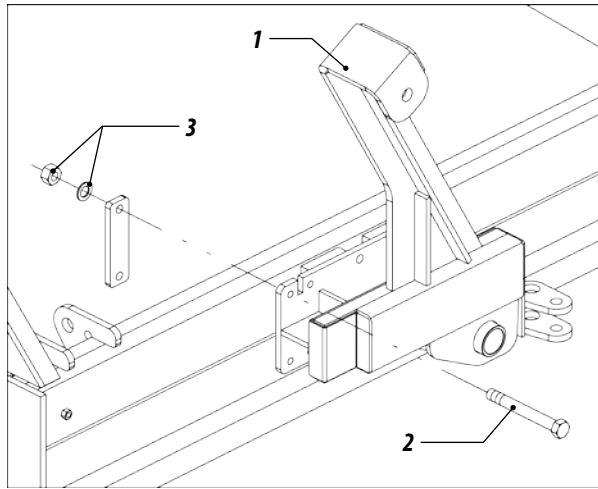

Figure 12

29- Then mount the piston (7) with the coupling pins (8), washers and latches (9), figure 14.

ATTENTION

Observe the insertion of pins in order for latch item 09 to not be beside the tire.

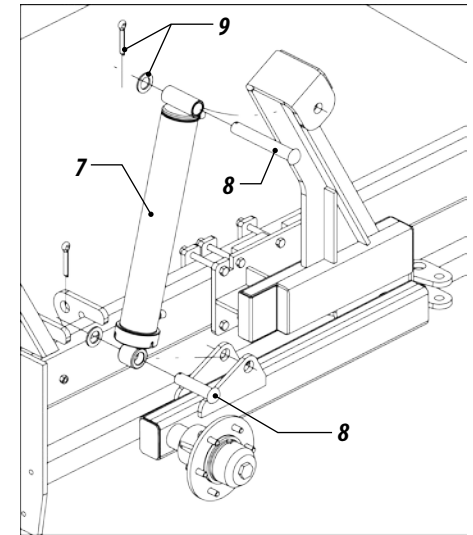

Figure 14

28- Insert the rod (4) in the bracket (5) fastening it with washer and nut (6), figure 13.

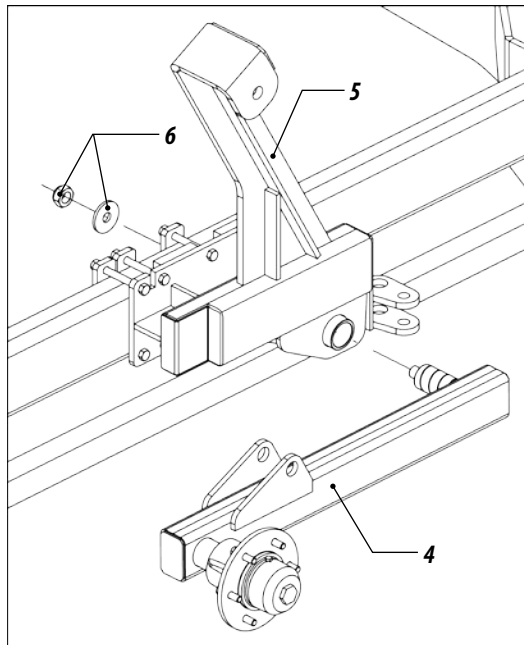

Figure 13

30- Raise the seed drill onto the hydraulic of the tractor and couple the tire (10) through the pins (11), figure 15.

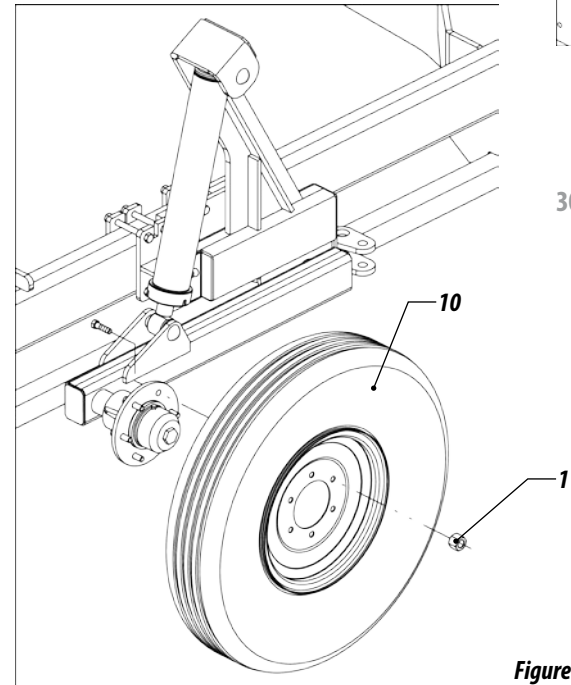

Figure 15

WHEELSET FOR TRANSPORT (REAR SIDE OF FRAME)

• To mount the wheelset for transportation, on the rear part of the seed drill, proceed as follows:

31 - Remove the platform (1) through the screws (2), washers and nuts (3) and the counterweights (4), according to the number necessary to attach the bracket of the wheelset, figure 16.

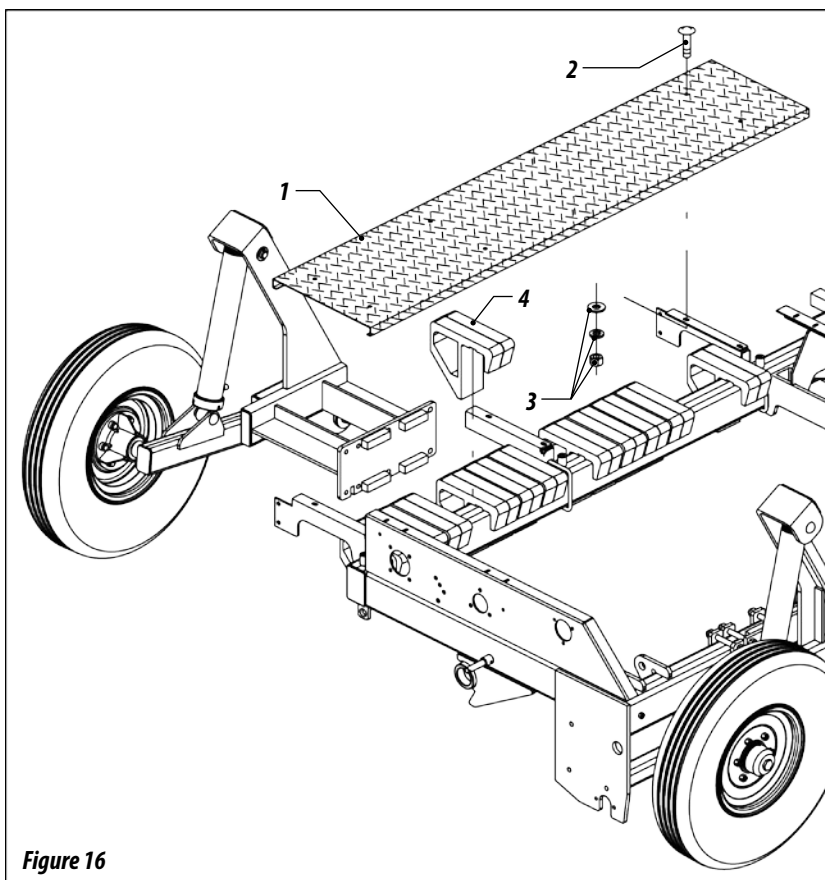

Figure 16

32 - Then attach the wheelset bracket (5) to the frame through screws (6), nuts and washers (7). FIGURE 17. After, put the platform (1) back and retighten the screws.

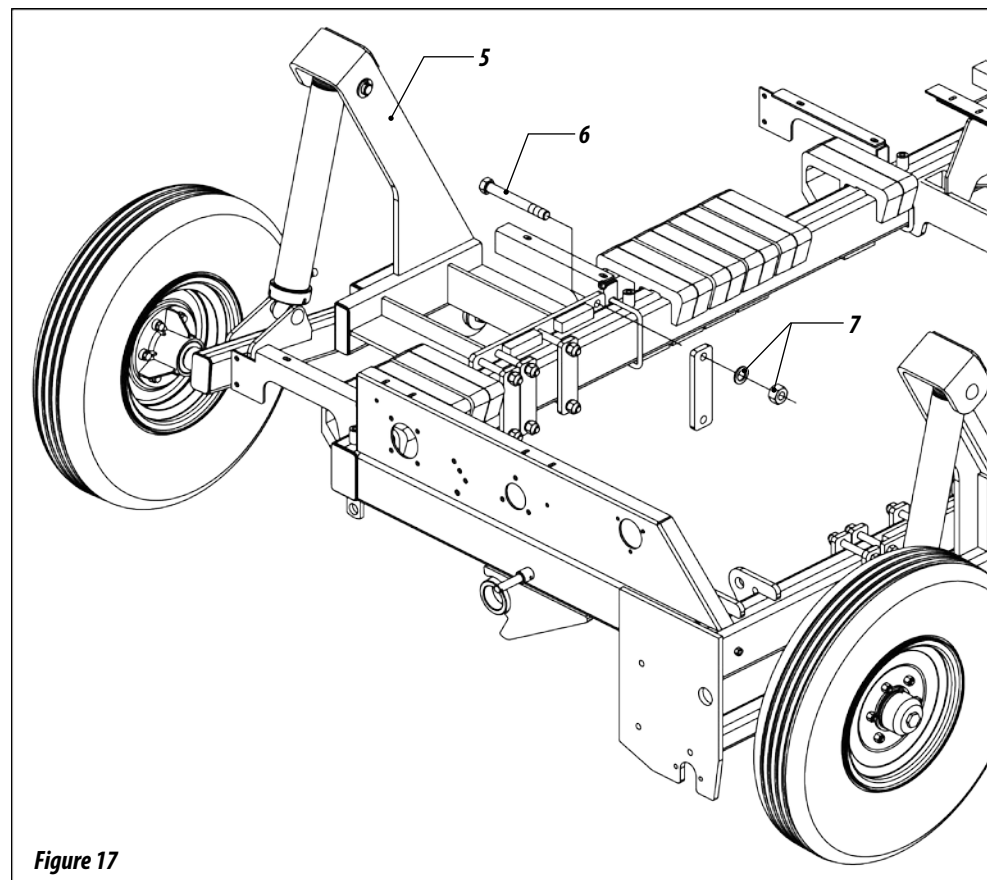

Figure 17

**ATTENTION**

Remove the necessary number of counterweights in order to attach the wheelset to the back of the seed drill.

SIDE FRAME

33- Attach the side frame (1) to the front frame (2) through the pin (3) and latch (4), figure 18.

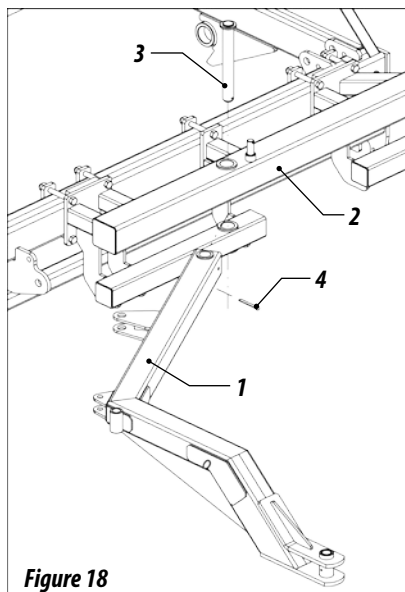

Figure 18

OPENING PISTON AND LOCK BAR OF HEADER

34- Couple the piston (1) to the bracket (2) through the pins (3) and latches (4)
35- 2 – After, place the lock bar (5), on the side frame (6) and rear bracket (7), latching with the pins (8) and latches (9), figure 19.

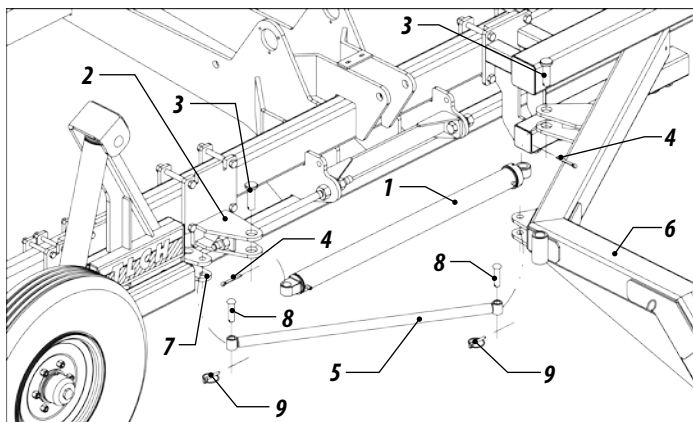

Figure 19

COUPLING HEADER

36- Then mount the coupling header (10) to the side frame (6), fastening with the pin (11), washer and latch (12), figure 20.

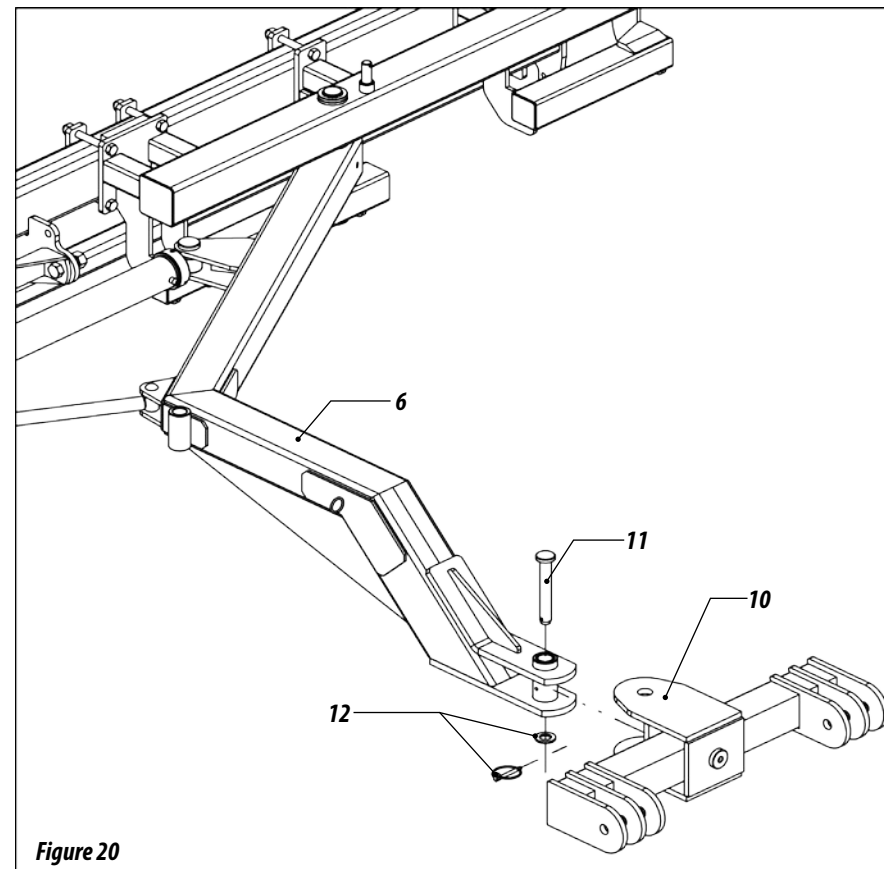

Figure 20

IMPORTANT

Observe the alignment of item 06 in relation to the center of the seed drill after full retraction of the piston, through the control handle of the hydraulic arms of the tractor.

ELECTRICAL SYSTEM

- 37 - The electrical system leaves the factory already mounted, however, it is not necessary to make changes in the cable connections but it is necessary to leave them prepared for use, as indicated below:
- 38 - Attach the valve (1) to the bracket (2) of the seed drill using the screws (3);
- 39 - Then do the same with synchronizing valves (4);
- 40 - Afterwards turn on the hoses, observing the appropriate lengths and terminals, details "B".

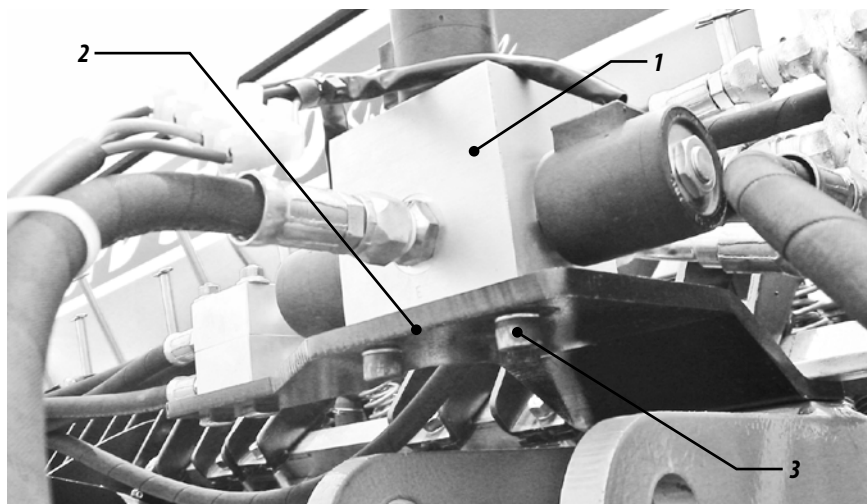

Figure 21

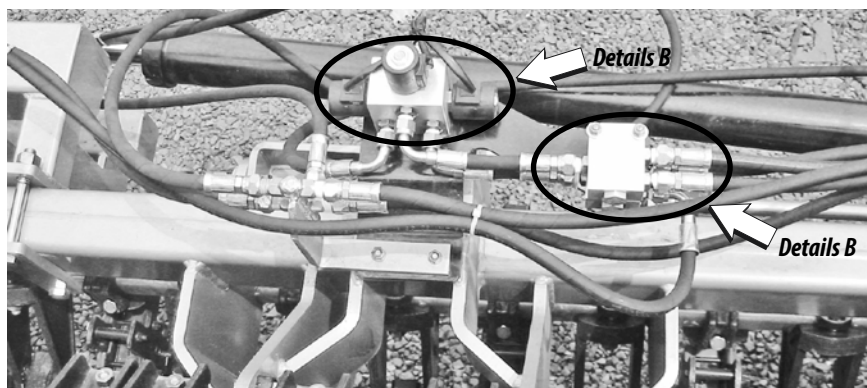

Figure 22



Details A

Figure 23

IMPORTANT

During mounting of the hoses, make sure that they are not bent or twisted, details "A".

CONNECTION OF THE CONTROL PANEL

41 - Attach the control panel (1) to a place of easy access and that does not interfere or disturb the handling of the tractor controls figure 24.

ATTENTION

Avoid strong impacts on it.

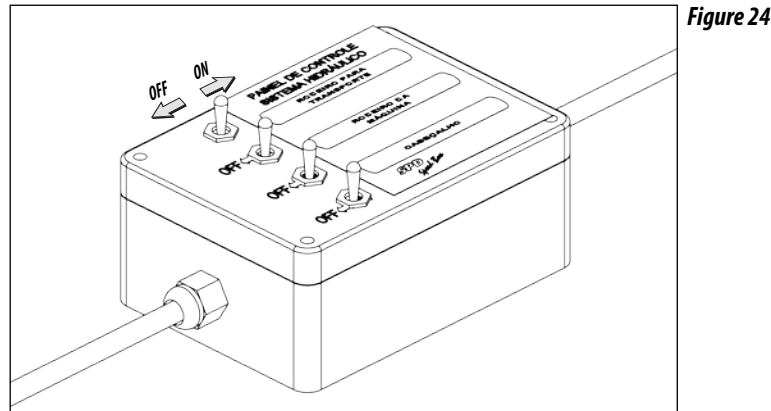

Figure 24

42 - Couple the cable (2) of the panel to the tractor battery Detail "A", figure 25.

Figure 25



43 - Connect the negative cables - black (3) and positive cables - white (4) to the tractor battery (5). Detail "B", figures 26 et 27.

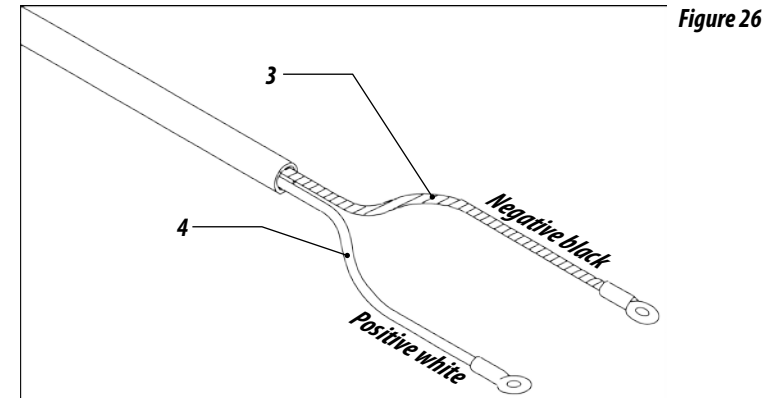

Figure 26

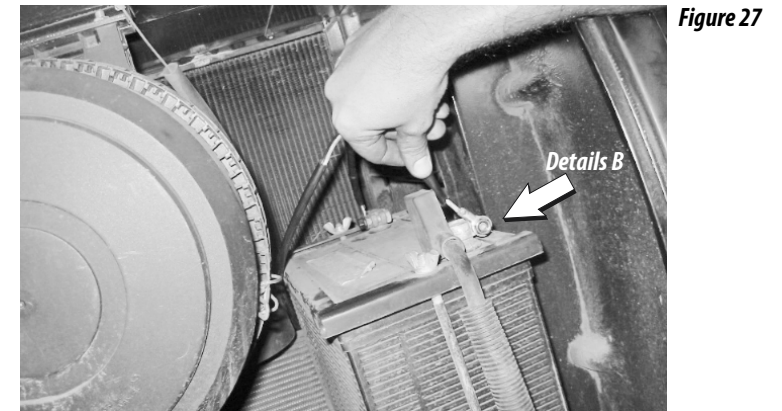
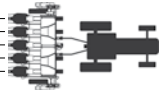

Figure 27

ATTENTION

Never connect the cables to the battery with the tractor in operation. After executing the operations, leave the control panel switch in the OFF position, preventing the battery from discharging.

05 PREPARATION OF THE SEED DRILL FOR TRANSPORT



- Before couple the Seed drill in the tractor check If tractor is compatible for work, observing the follow item:
- To couple the seed drill, proceed as follow:
 - 01 - Level the drawbar (1) of seed drill in the three point of the tractor (2). Then approach slowly the tractor to the tractor into reverse, with attention in the brake.
 - 02 - Proceed the coupling of seed drill to tractor fixing the pin through drawbar tractor (3) and lock (4).

Figure 28

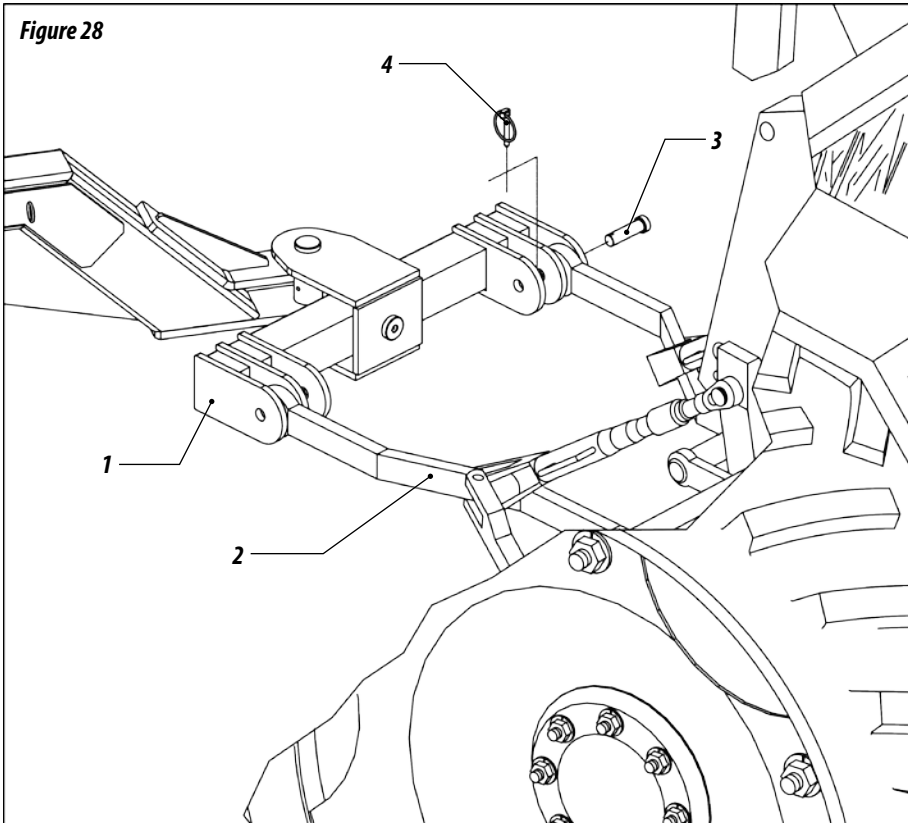

- 03 - Couple the hoses (5) in the hydraulic system of the tractor.

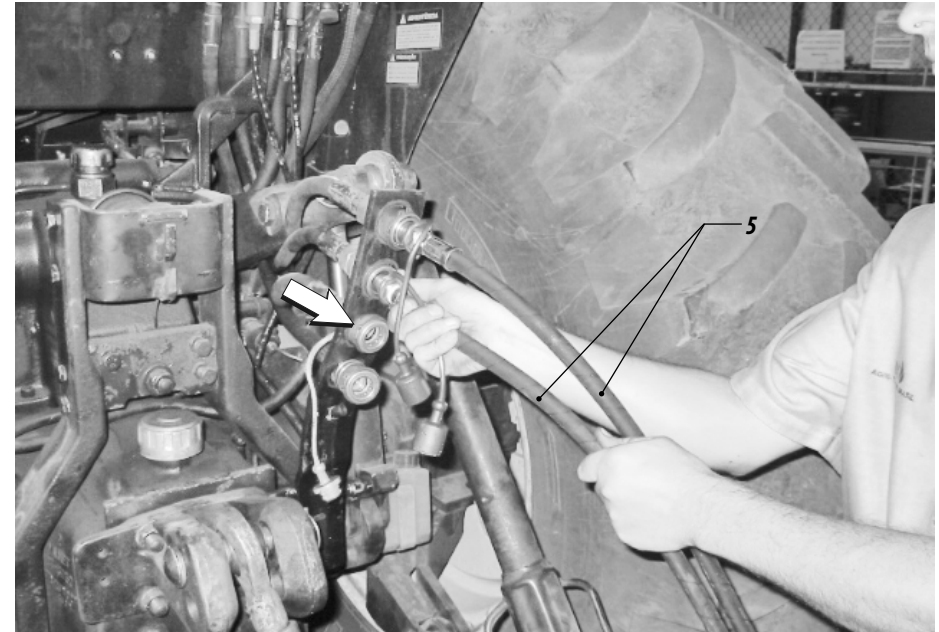

Figure 29

ATENTION

Before connect or disconnect the hoses of the hydraulic system, turn off the tractor and Relieve the hydraulic system pressure. Check if when you relieve the pressure nobody are near the equipment.

IMPORTANT

When couple the equipment, find some área safe and easy access, use always slow speed with low RPM.

SEED DRILL TRANSPORT

• Before effect the transport of seed drill, proceed as follow:

04 - Lift the tyres for transport (6), (key 1 of the control panel) (7), as according shown the drawing 30 and 31.

Figure 31

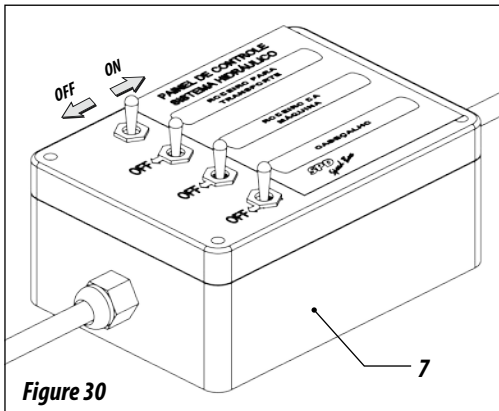

05 - Collecting the support, (6) fix with pin and (2) lock, as shown drawing 32.

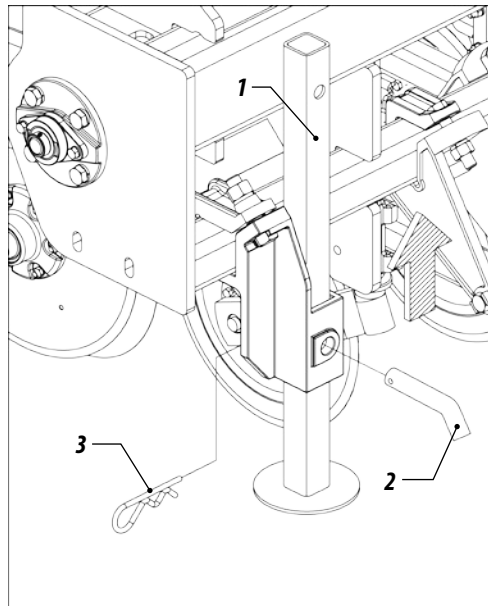

Figure 32

06 - Lift the arms of the hydraulic tractor (8), as shown drawing 33.

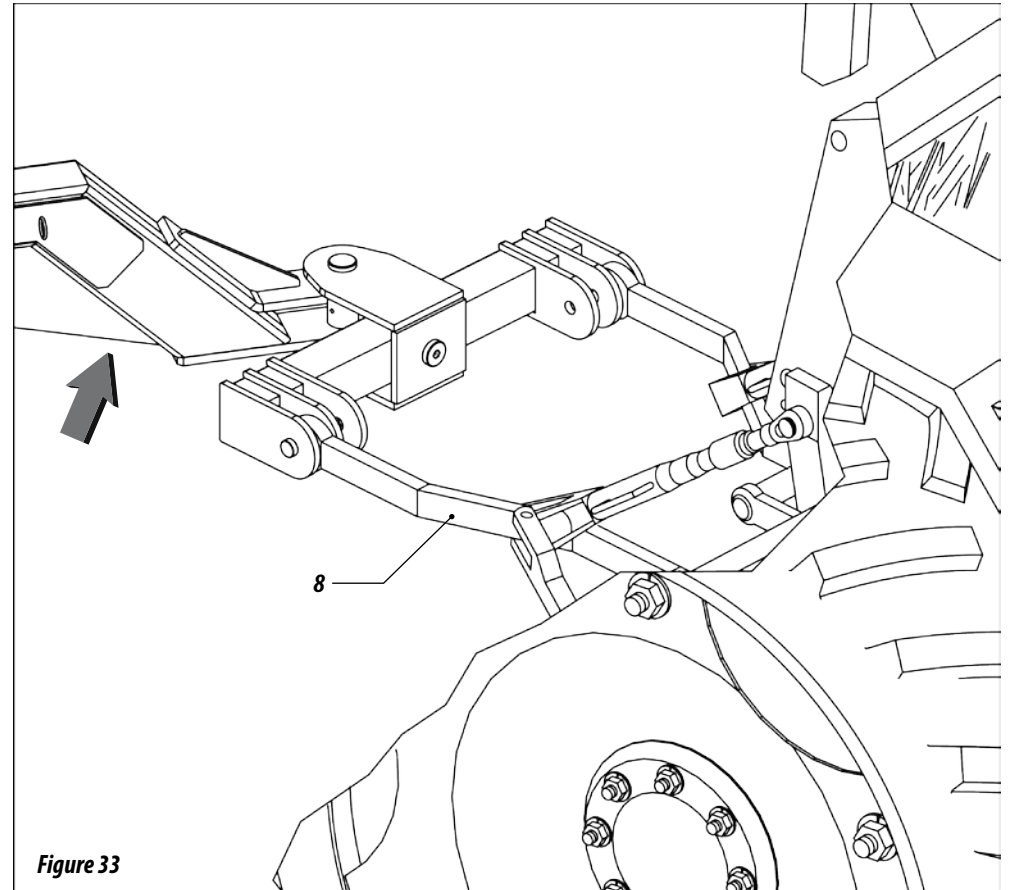
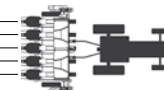

Figure 33

06 HEADER OPENING OPERATION FOR WORK



01 - Lower the parking support (1) on both sides of the seed drill until they touch solid ground, latching with the pin (2), figure 34.



Figure 34

02 - Lower the hydraulic arms of the tractor, figure 35.

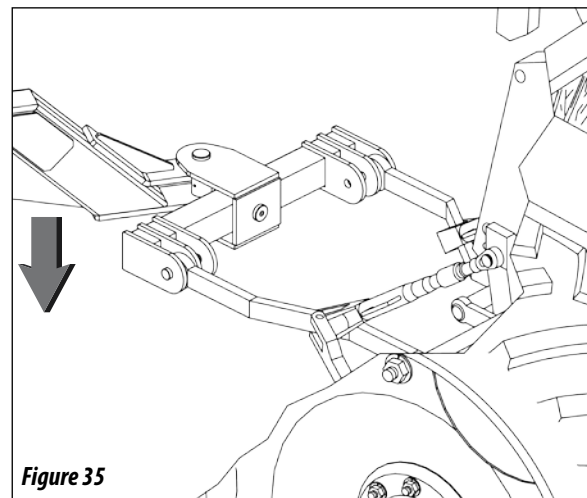

Figure 35

03 - Operate the transport wheelset (3) to lower the seed drill (key #1 on the panel), figure 36.

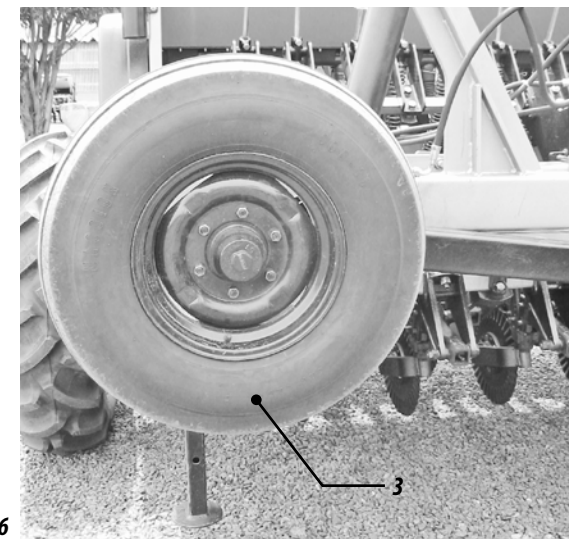

Figure 36

04 - Operate the rockshaft (4) of the seed drill detail "A" in the up position, in order to latch it by inserting the pin (5) and latch (6), leaving it fastened, figures 37, 38 and 39.

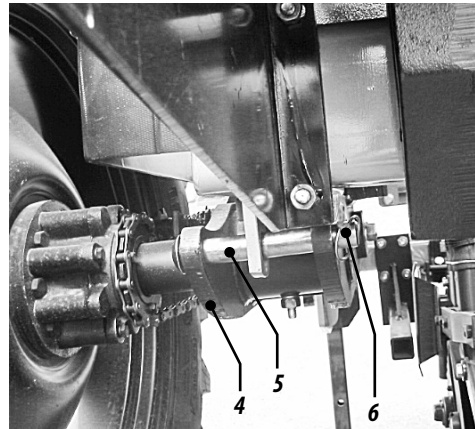
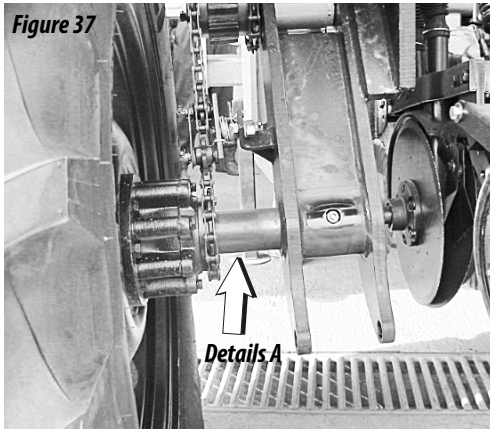

Figure 38

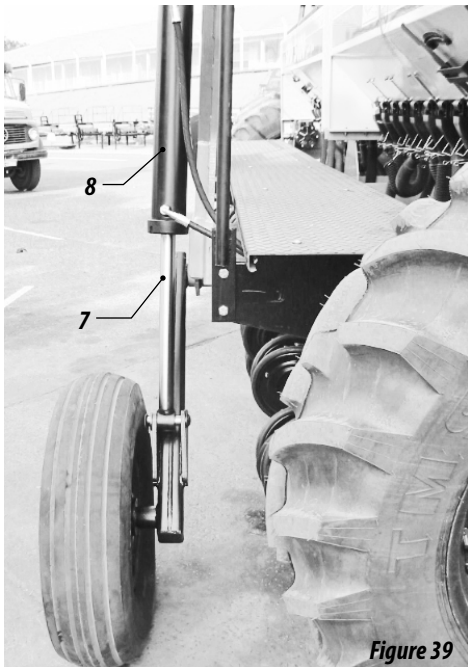

Figure 39

05 - Remove the lock pin (9) of the header, moving the tractor in order to enable the removal, figure 40.

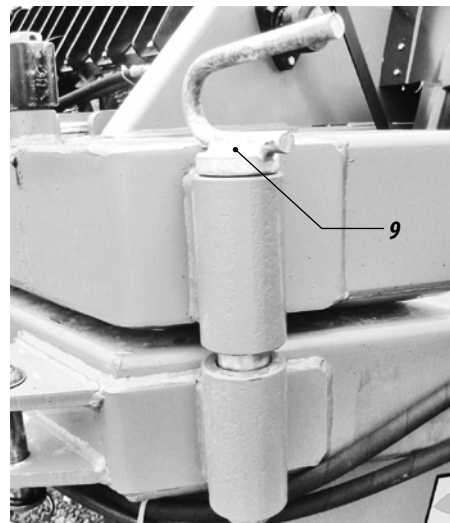

Figure 40

06 - To raise the seed drill, operate the transport wheelsets (10) on switch #1 of the panel, figure 41.



Figure 41

07 - Raise the hydraulic arms of the tractor (11), figure 42.

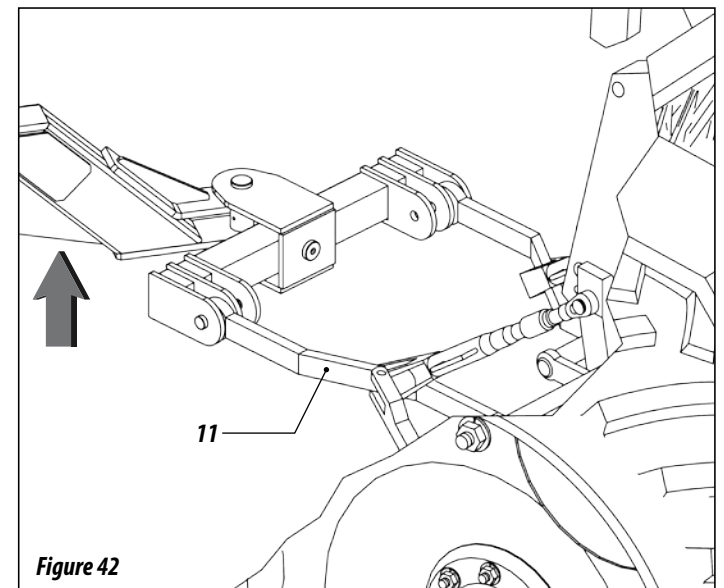

Figure 42

08 - Operate the wheelsets (12) of the seed drill in order to raise it (key #2 of the panel), figure 43.



Figure 43

10 - Lower the hydraulic arms of the tractor (14), figure 45.

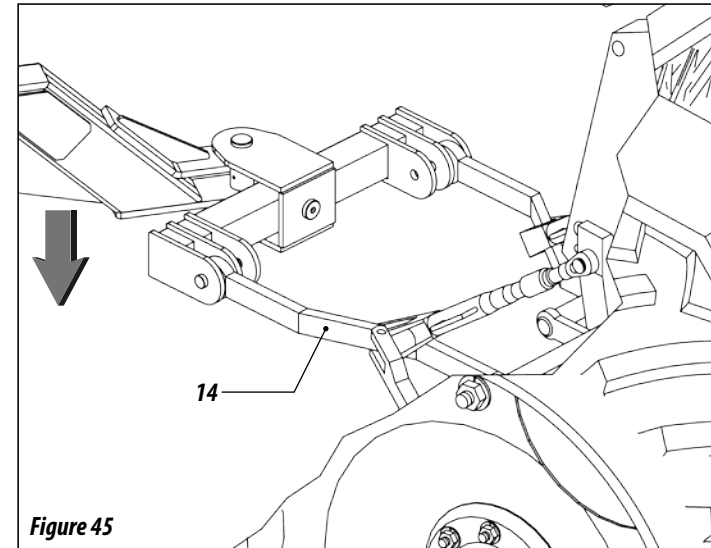

Figure 45

! ATENTTION

Do not perform this operation with the tractor brake activated.

09 - Operate the hydraulic piston (13) to open the header using switch # 3 of the panel, figure 44.

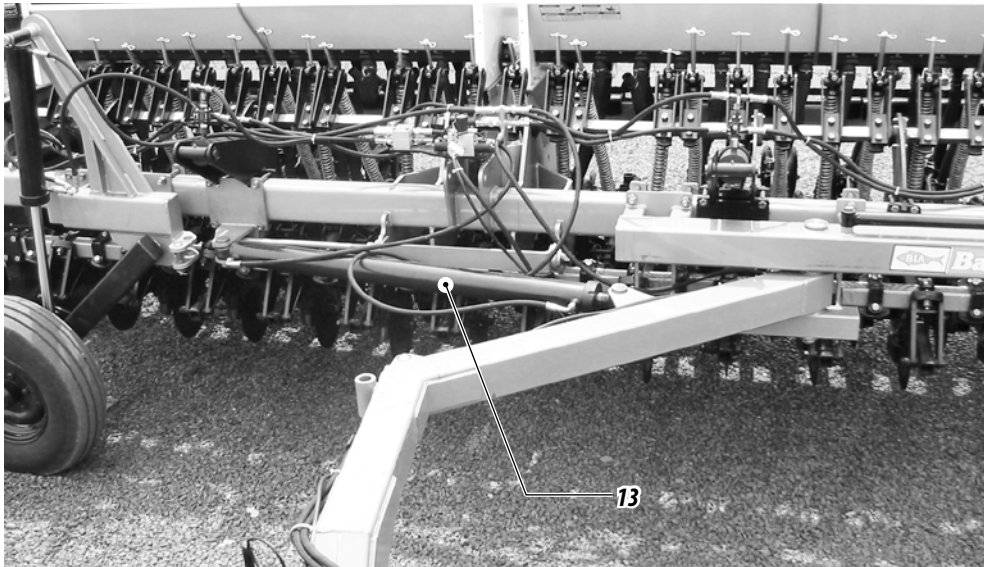

Figure 44

11 - Operate the transport wheelsets (15) to lower the seed drill (key #1 on the panel), figure 46.

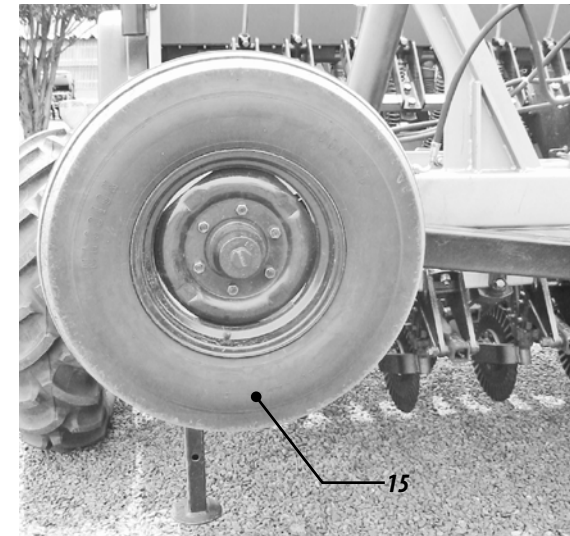

Figure 46

- 12- To lower the seed drill, operate the transport wheelsets (16) upward (switch #2 of the panel), figure 47.



Figure 47

- 13- Operate the hydraulic piston (17) to open the header, using switch # 3 of the panel, then insert the latch (18) of the header, figure 48.

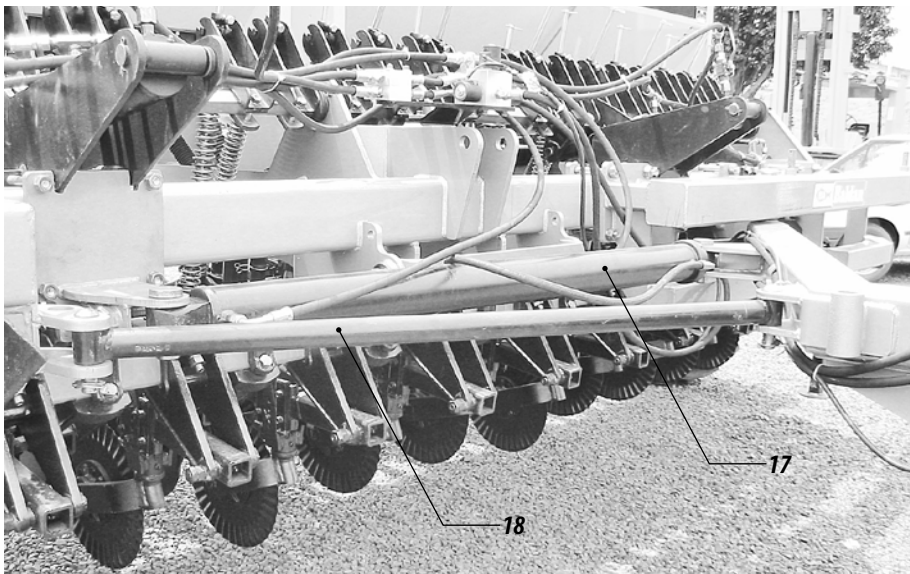

Figure 48

- 14- Operate the wheelsets (19) of the seed drill in order to raise it (key #2 of the panel), figure 49.

Figure 49



⚠ ATENTION

Ne pas faire cet opération avec le frein du tracteur actionné.

- 15- Retract the parking support (20), latch with the pin (21), figure 50.



Figure 50

16- To lower the seed drill, operate the transport wheelsets (22) upwards (switch #2 of the panel), figure 51.



Raise the wheelset

17- After executing the previous operations, observe the Seed drill in the working position in detail "A", figure 52.

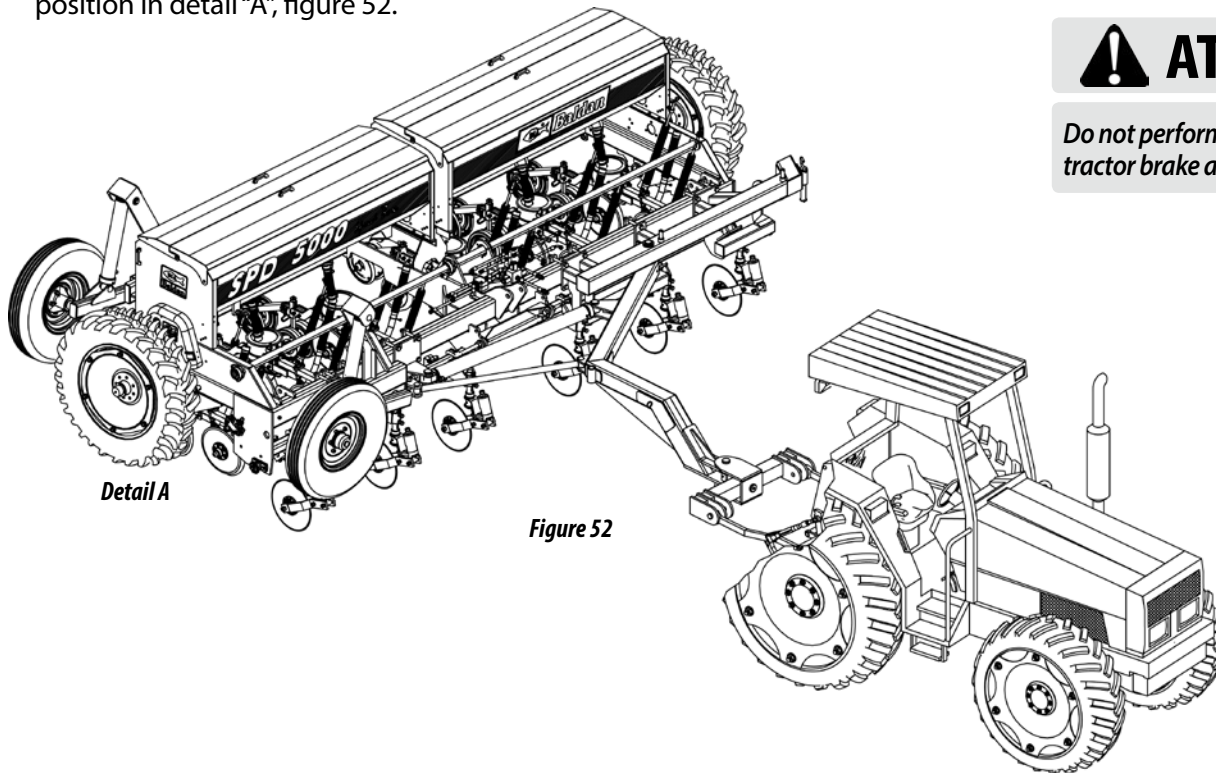
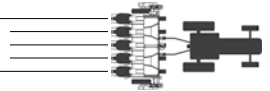

Figure 52

07 CLOSING OF THE HEADER



- With the seed drill coupled to the tractor in the working position, follow the sequence below to put it in the side transport condition.

PREPARATION FOR TRANSPORT AFTER WORK

- 01- Operate the wheelsets (1) of the seed drill in order to raise it (key #2 of the panel), figure 53.

Figure 53



! ATENTION

Do not perform this operation with the tractor brake activated.

- 02- Lower the parking support (1) on both sides of the seed drill until they touch solid ground, latching with the pin (2), figure 54.

Figure 54



- 03 - To lower the seed drill, operate the transport wheelsets (4) upwards, (switch #2 of the panel), figure 55.

Figure 55

Raise the wheelset



- 04 - Remove the latch (5) that connects the header to the frame through the pins (6) and latch (7). Then activate the hydraulic piston (8) to close the header, figure 56.

Figure 56

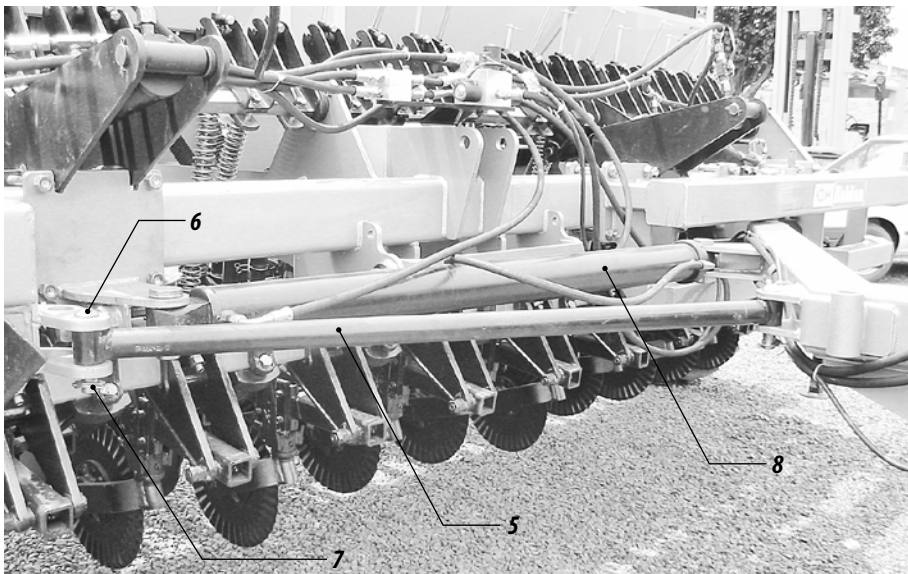

- 05 - Operate the wheelsets (9) of the seed drill in order to raise it (key #2 of the panel), figure 57.

! ATENTTION

Do not perform this operation with the tractor brake activated.



Figure 57

- 06 - Operate the wheelsets (10) of the transport in order to raise it (key #1 of the panel), figure 58.

Figure 58

! ATENTTION

Do not perform this operation with the tractor brake activated.

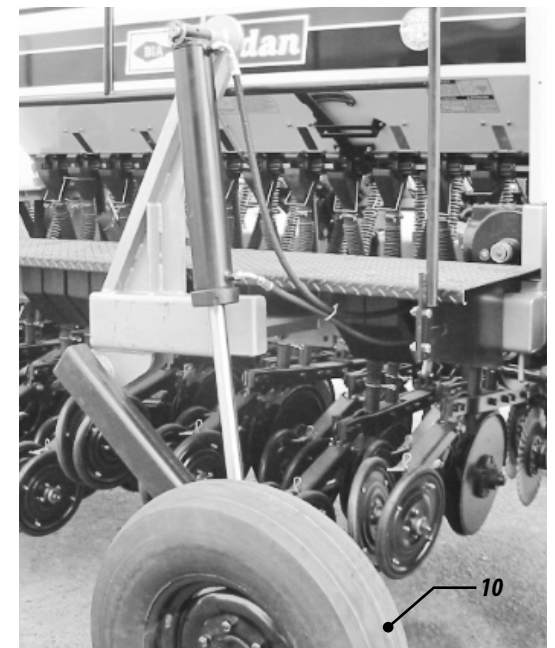

07 - Raise the hydraulic arms of the tractor (11). figure 59.

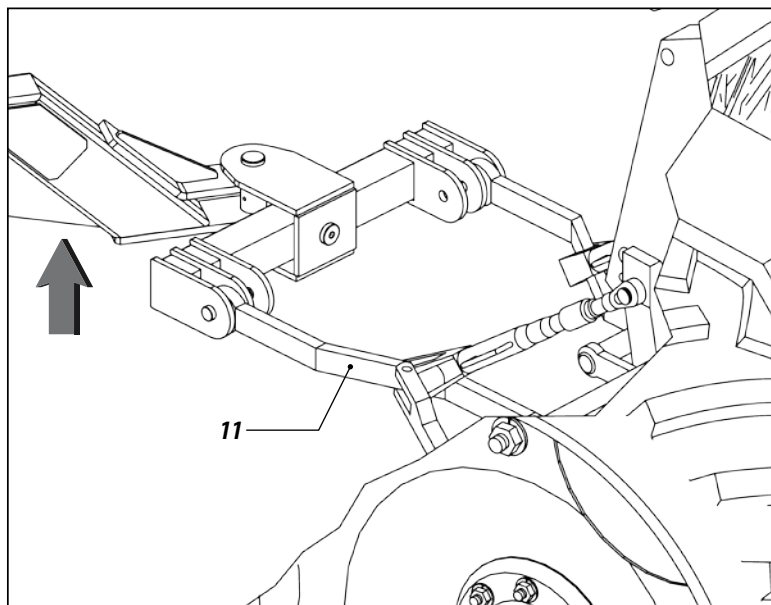

Figure 59

08 - Activate the opening piston (12) through the hydraulic control of the tractor, observing the displacement of the header (13) according to figure 60.

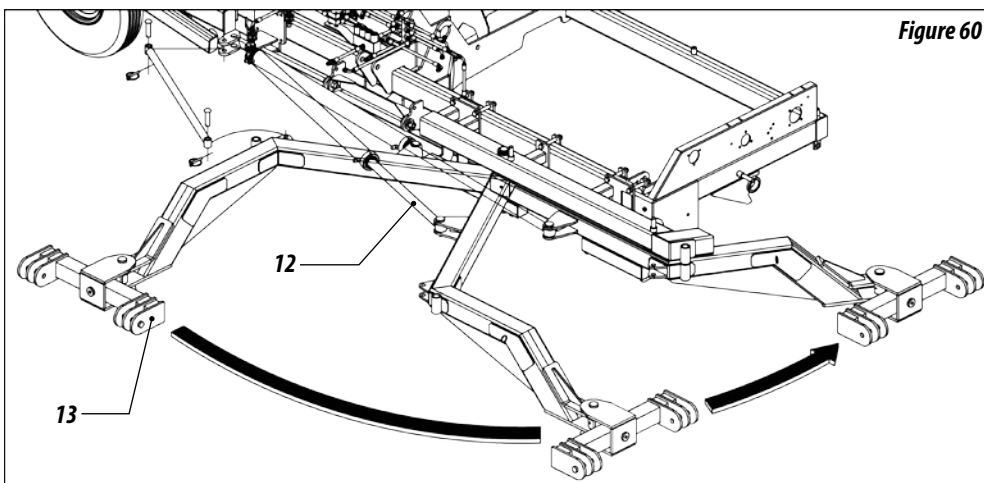

Figure 60

! ATENTION

When performing operations, prevent people from staying too close to or over the seed drill. This can cause serious or even fatal accidents.

09 - After completely opening the piston and putting the header in the position to transport the seed drill, attach the lock bar (14) to the front frame (15) through the latches (16), figure 61.

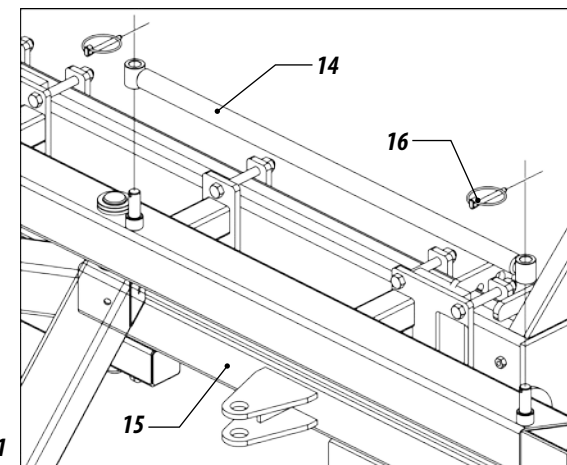

Figure 61

10 - Next, lock the header with the pin (17) and latch (18), figure 62.

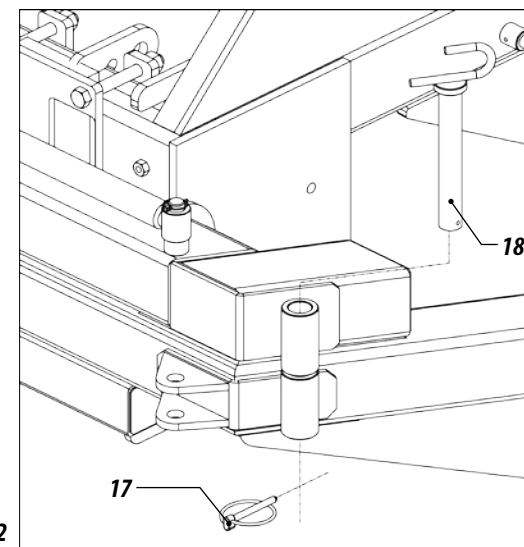

Figure 62

11- To lower the seed drill operate the wheelsets (19), (switch #2 of the panel), figure 63.

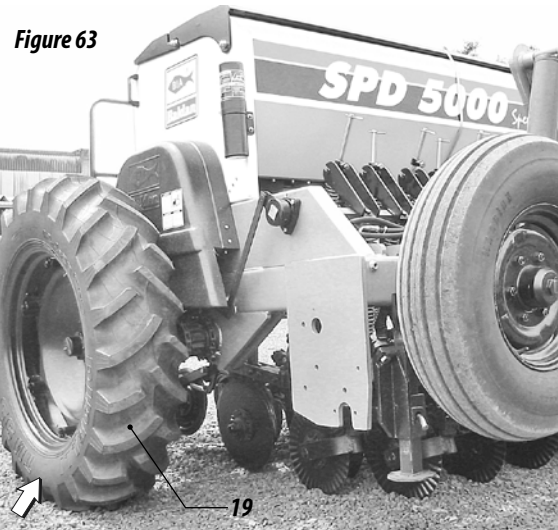

Figure 63

Raise the wheelset

12- Lower the hydraulic arms of the tractor (20), figure 64.

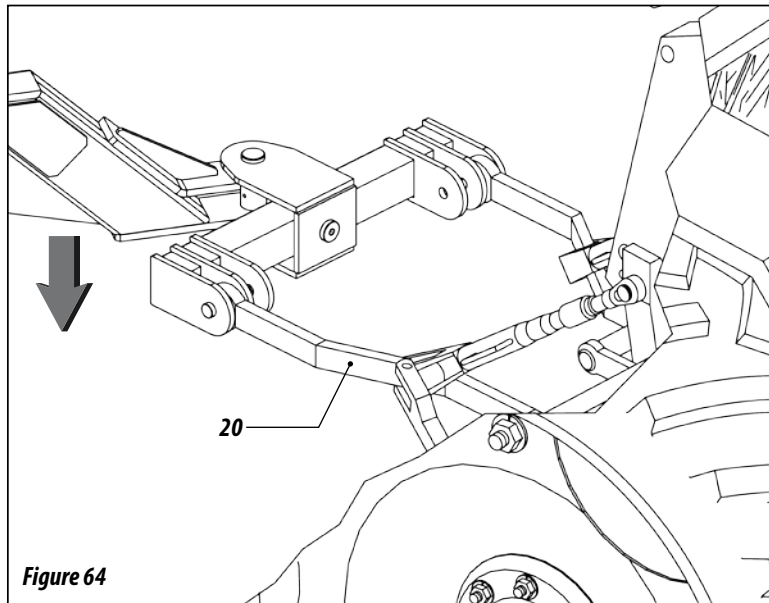

Figure 64

13- Operate the transport wheelsets (21) to lower the seed drill (key #1 on the panel), figure 65.



Figure 65

14- Operate the rockshaft (22) of the seed drill detail "A" in the up position, in order to latch it by inserting the pin (23) and latch (24), leaving it fastened. Figure 62. figures 66 et 67.

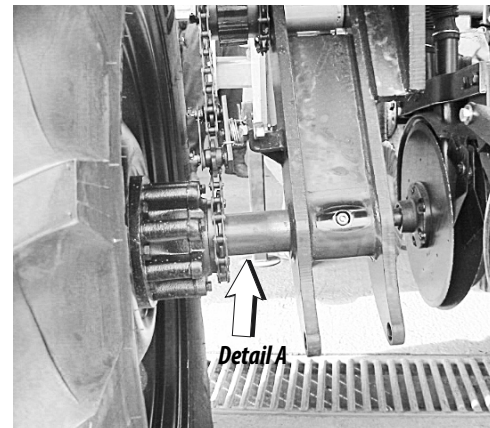

Figure 66

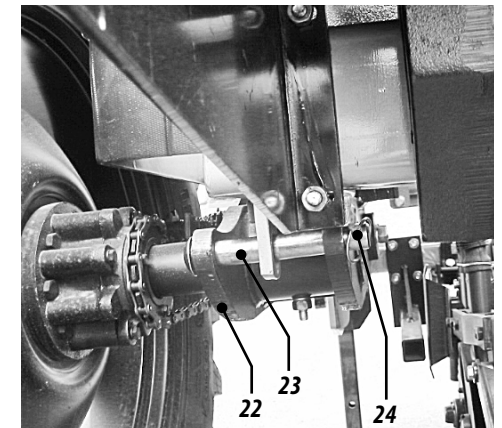

Figure 67

15 - Operate the wheelsets (25) of the transport in order to raise it (key #1 of the panel), figure 68.



Figure 68

⚠ ATTENTION

Recommended transport speed:
 Unpaved road = 10 km/hr
 Paved road = 40 km/hr (maximum)

🔑 IMPORTANT

Do not transport the seed drill without the latches on the center and wheelset piston rods.
 Do not transport the seed drill loaded because it can damage the equipment; it is recommended to only supply it at the worksite. If the equipment remains in the field due to any reason, it is recommended to cover it with waterproof sheet to prevent moisture.

16 - Before transporting the seed drill, put the latch (26) on the transport wheelset piston rod (27) through the pin (28) and retaining pin (29) according to figure 69.

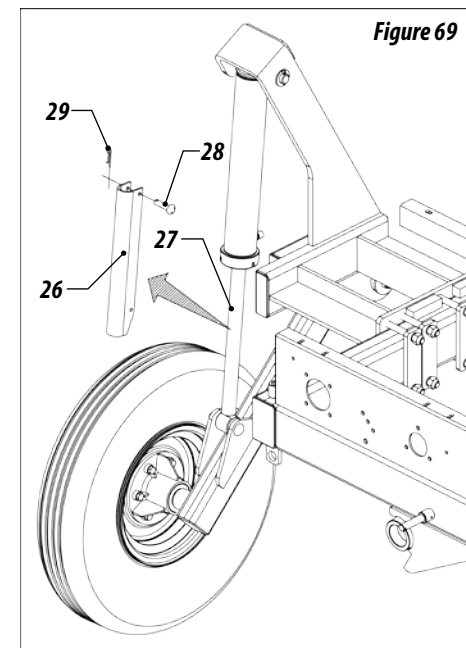

Figure 69

17 - Lower the hydraulic arms of the tractor (30), figure 70.

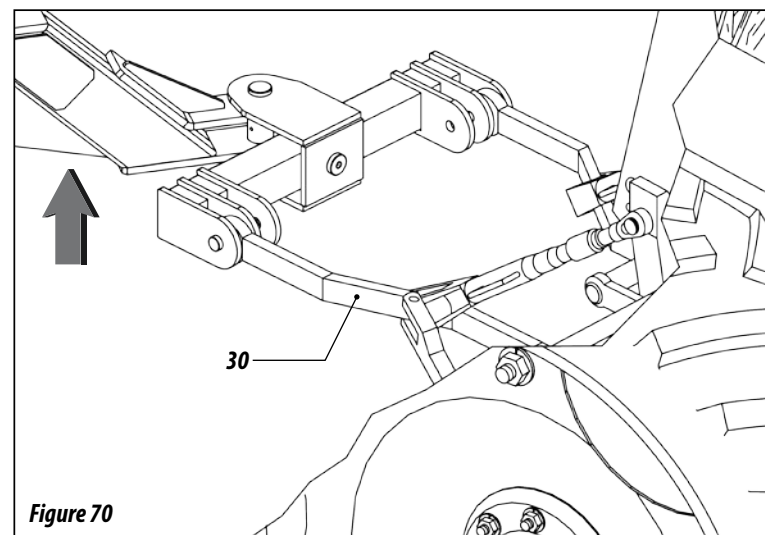
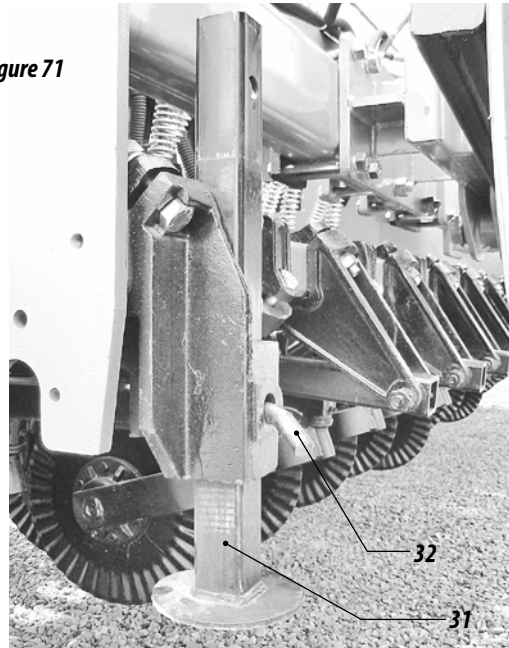

Figure 70

18- Retract the parking support (31), latch with the pin (32), figure 71.

Figure 71



20- Total width for transport, figure 73.

Figure 73



19- Seed drill ready to be transported, observe leveling in relation to the tractor and the ground. According to figure 72.

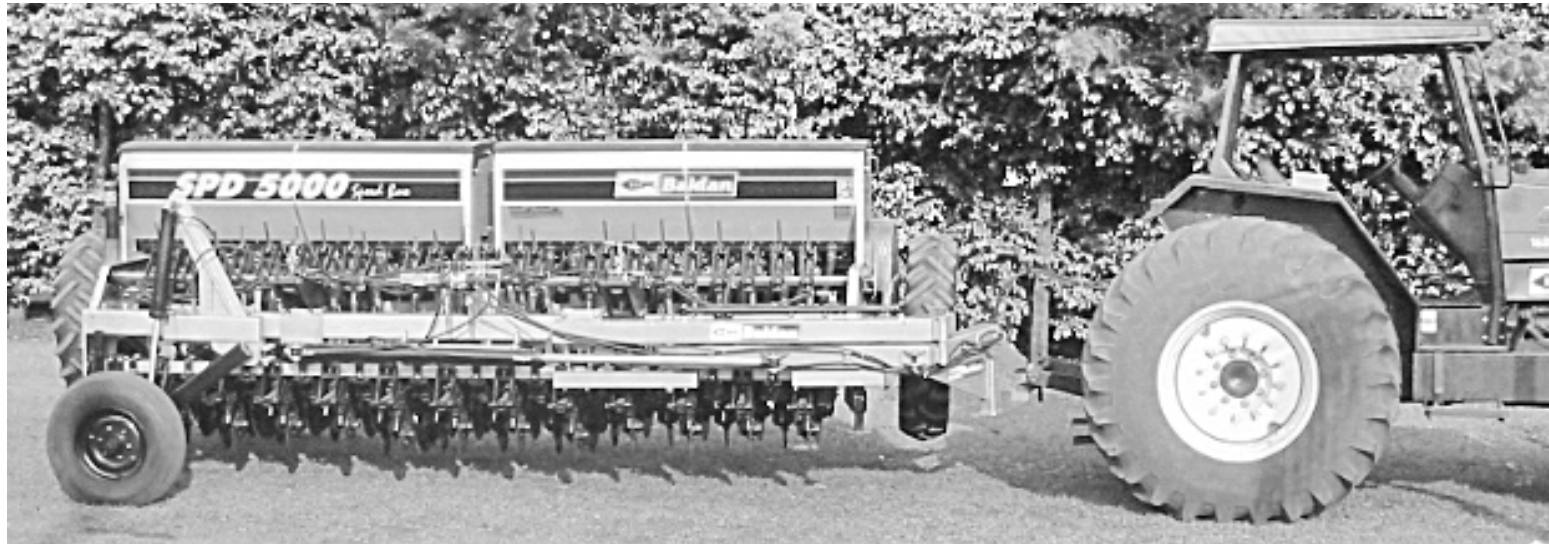
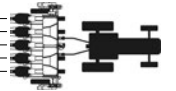

Figure 72

! ATENTION

Do not transport the seed drill loaded because it can damage the equipment.

08 LUBRICATION (SIDE TRANSPORT SPD - 5000)



- 01 - Lubrication is indispensable for a good performance and higher durability of the moving parts of the system, which helps economize maintenance costs.
- 02 - Before executing the operation, carefully lubricate all greasers, always observing the lubrication intervals.
- 03 - Check the quality of the lubricant in relation to its efficiency and purity, avoiding the use of products contaminated with water, soil and other agents.

LUBRICATE EVERY 60 HOURS OF WORK

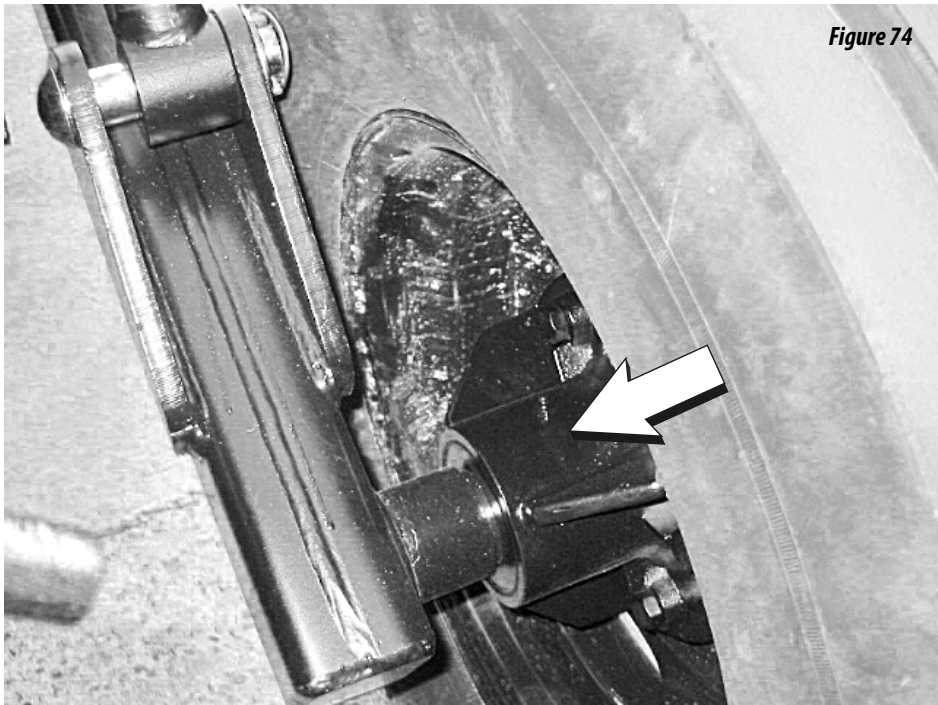

Figure 74

LUBRICATE EVERY 200 HOURS OF WORK



Figure 75



Figure 76

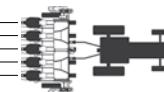

- Before attaching the planter on the tractor check if the tractor ready to use, following the instructions bellow:
- 01 - Inspect if the tractor has the correct extra-weight this procedure will provide more stability and more tractor-to-soil contact.
- To hitch the planter on the tractor follow the instructions bellow:
- 02 - Align the planter drawbar (#1) with the tractor, using the adjuster device (#2), then slowly back the tractor up to engine,
 - 03 - Couple the tractor on the planter using the pin (#3), and lock (#4).
 - 04 - Connect the hose on the tractor quick couple (#5).

ATENTION

Before connecting or disconnecting the hydraulic hoses, stop the engine and release the pressure of the hydraulic system by fully activating the control handles. Make sure no one is close to the area of equipment movement when releasing the pressure of the system.

IMPORTANT

Hitch the unit in a safe place during daylight or with good artificial light at a slow speed.

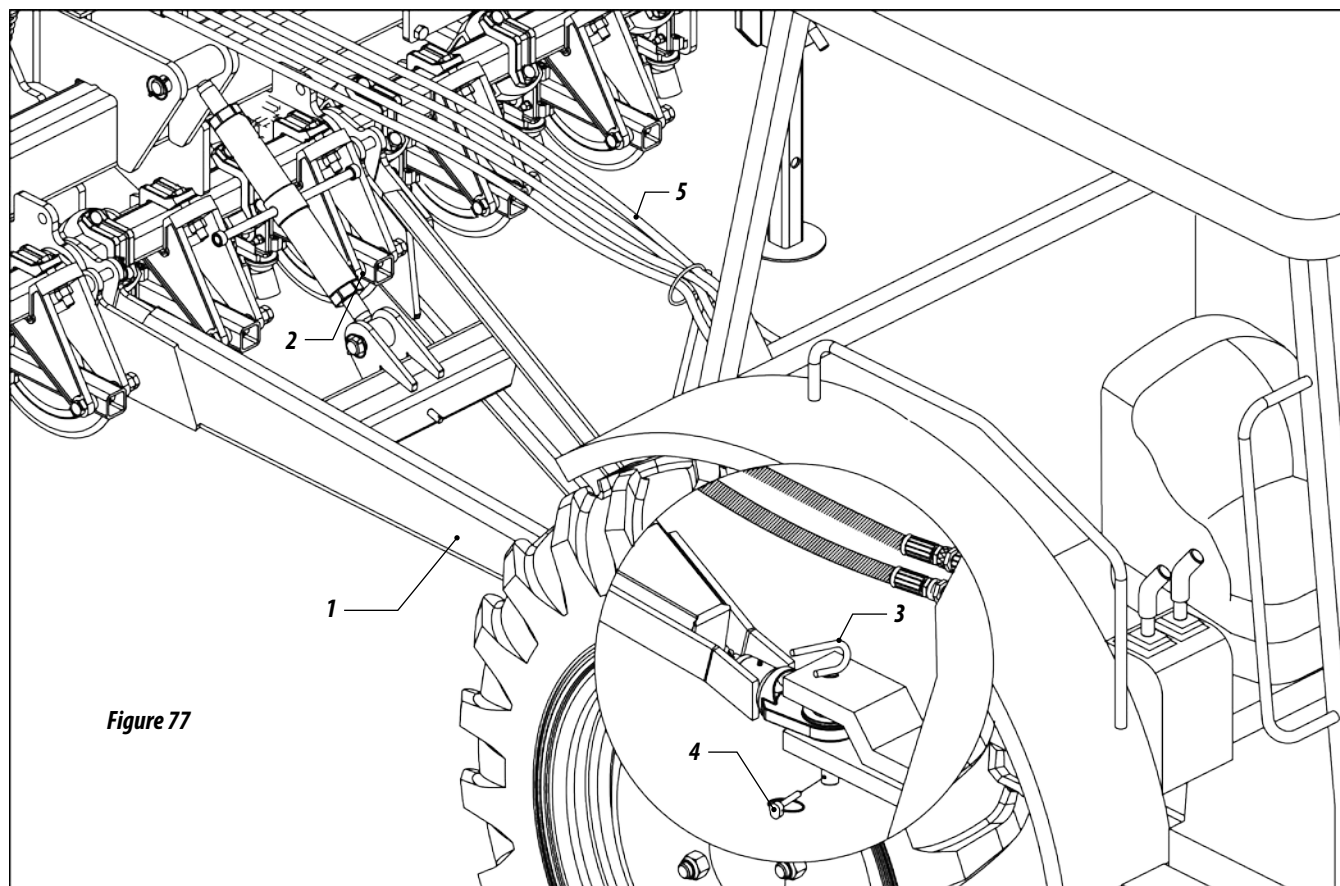
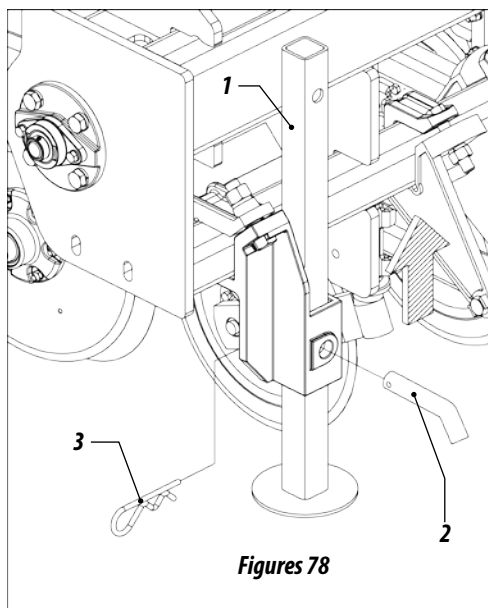

Figure 77

SEED DRILL TRANSPORT

• Before transporting the seed drill follow this instruction below:

05 - Raise the stand (#1) and lock with the pin (#2) and hair pin (#3).



Figures 78

06 - Fully raise the rows using the hydraulic cylinder, insert the lock (#4), on the rod of central hydraulic cylinders (#5), locking with the pin (#6) and hair pin (#7).

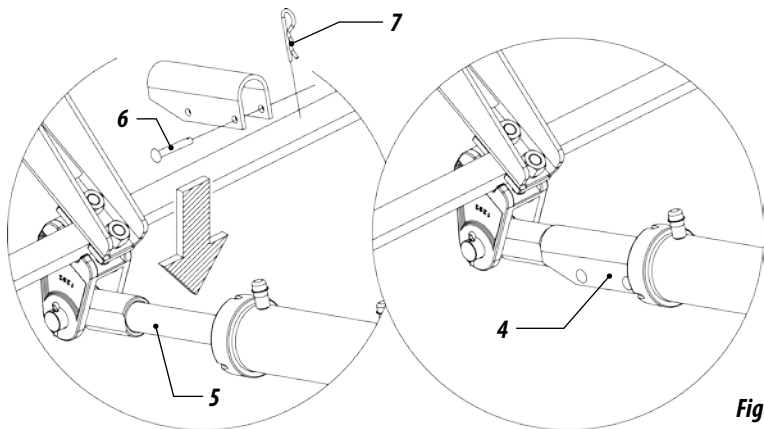

Figures 78

! ATENTION

Do not transport the seed drill without the lock in the central hydraulic cylinder.

07 - Before transporting the seed drill inspect if it is aligned with soil, to align use the adjuster device (#10) on the drawbar.

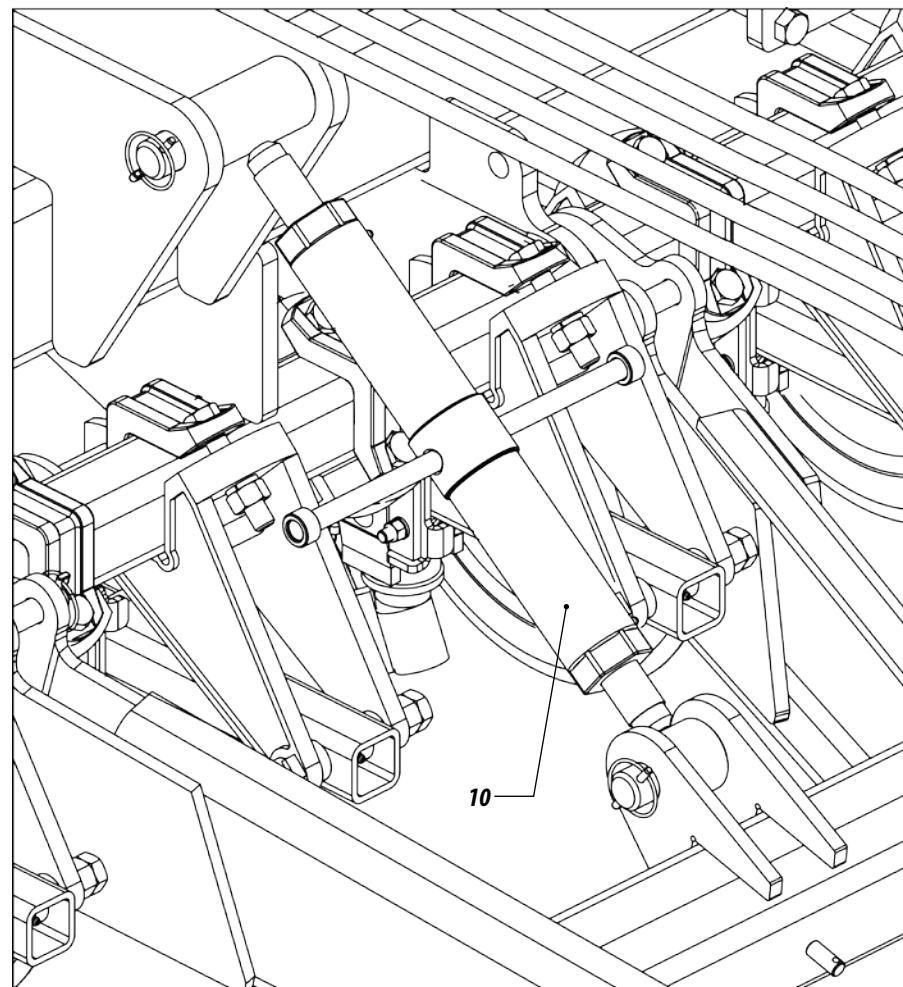

Figures 78

IMPORTANT

Do not transport the seed drill loaded because it can damage the equipment; it is recommended to only supply it at the worksite. If the equipment remains in the field due to any reason, it is recommended to cover it with waterproof sheet to prevent moisture.

08 - Turn the steps (#11), locking in this position to avoid touching the soil during transport as illustrated in view "A" and "B" bellow, figures 79.

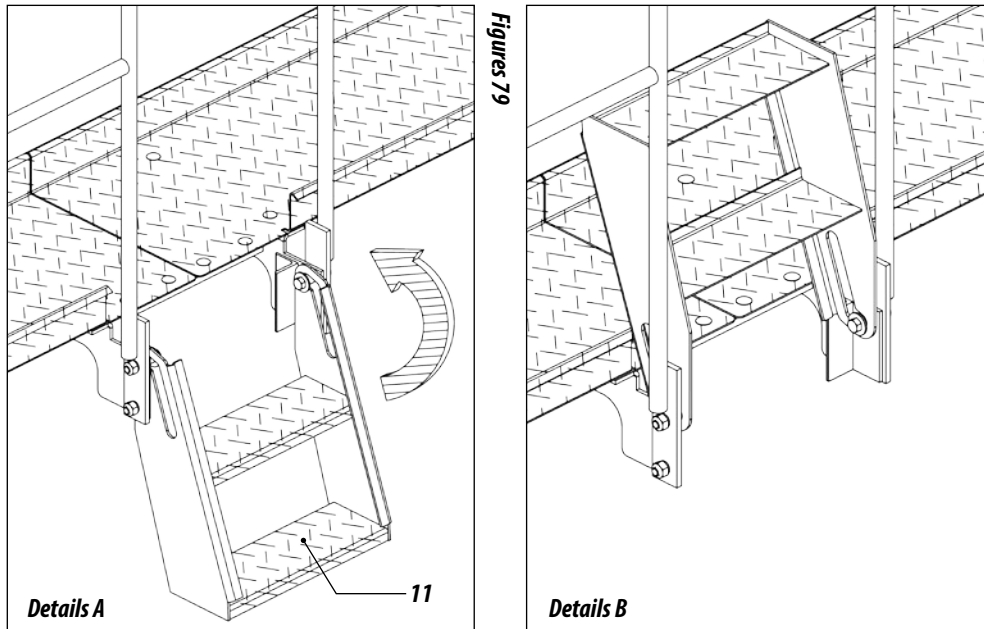

ATTENTION

Before transporting the seed drill read the information on page 37.

10

OPERATION

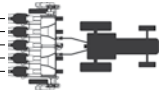

WORKING OPERATIONS

ATTENTION

If necessary use the limiter (#1) on the row hydraulic cylinder (#3) to set the depth.

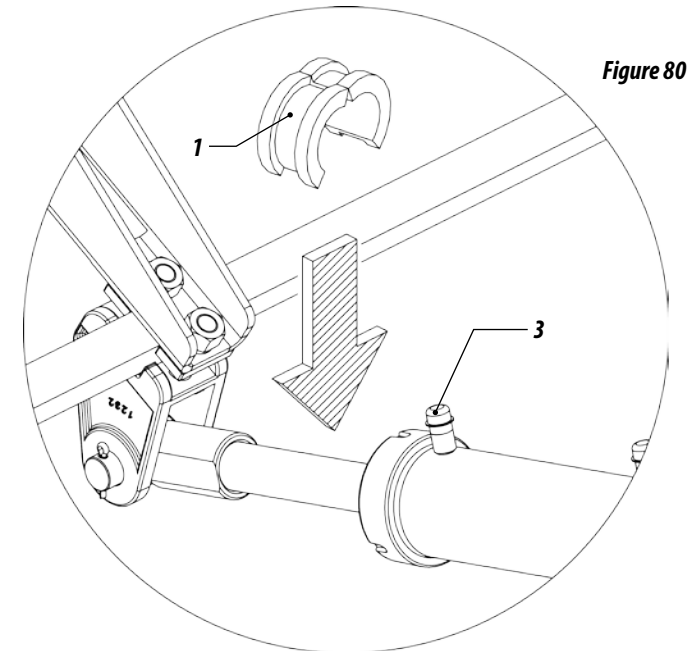

IMPORTANT

You can set the down force on the spring when the terrain requires.

SPACING BETWEEN ROWS

01 - Les semoirs sortent de l'usine avec écartement de 170 mm entre lignes pour le riz, le blé, l'avoine, etc, mais vous pouvez faire des nouveaux écartement selon le type de culture désirée.

TABLE OF MAXIMUM SPACINGS

Model	Useful width (mm)	Nr of Rows	Maximum Spacing (mm)
3000	2910	3	1455
		4	970
		5	727
		8	415
		9	363
		12	264
		16	194
4000	3590	4	1169
		5	897
		7	598
		10	398
		14	276
		17	224
		20	188
5000	4270	4	1423
		5	1067
		6	854
		7	712
		9	534
		12	388
		13	356
		15	305
		17	267
		24	185

Table 2

POSITION OF ROWS ON THE FRAME

- 02 - Determine the number of rows to be mounted on the seed drill.
- 03 - For uneven number of rows, attach a row to the center of the frame and move on to the others according to the desired spacing.

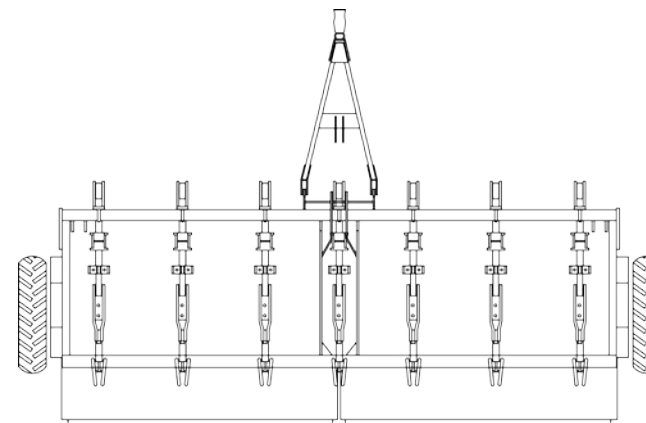

Figure 81

- 04 - For even number of rows, mark the center of the frame, divide a spacing and mark the middle spacing to the left and the middle to the right, then attach the first two rows there and move on to the others according to the desired spacing.

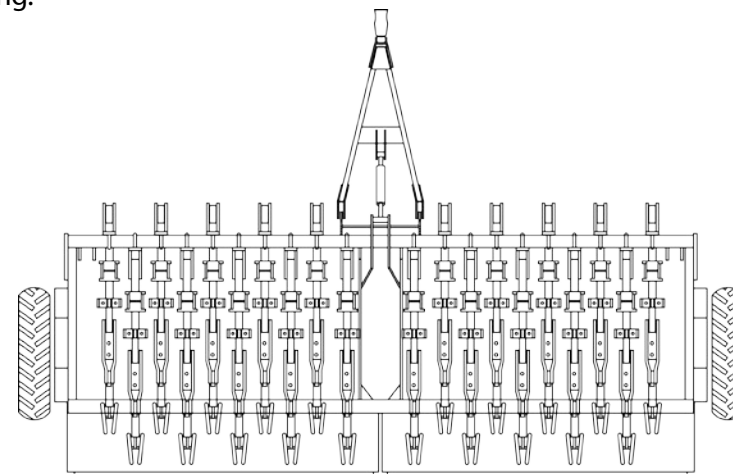

Figure 82

IMPORTANT

For bigger spacings (soybean and others), only use the parallel rows, if possible.

NEW SPACINGS

- 05 - Lower the parking supports (1), verifying that the seed drill is duly supported.
- 06 - Remove the nuts and screws (2) from the spring rod bracket, the fertilizer hose (3) and the seed hose (4).
- 07 - Loosen the nut (5), remove the bracket (6) and the complete row (7) that will not be used.
- 08 - After, reposition the rows in the new spacings.

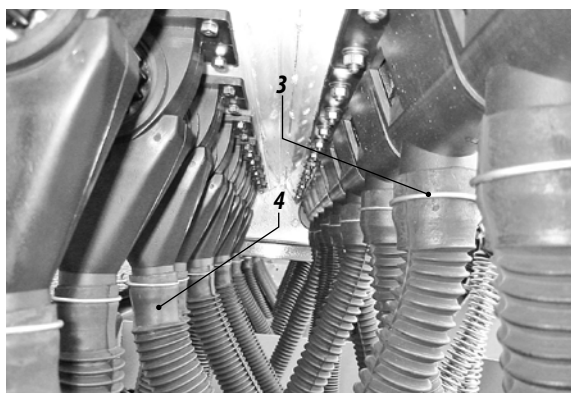
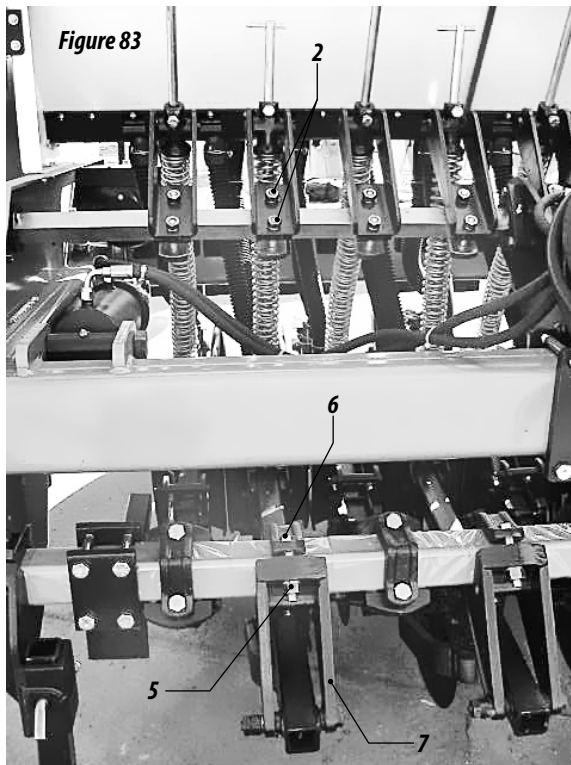
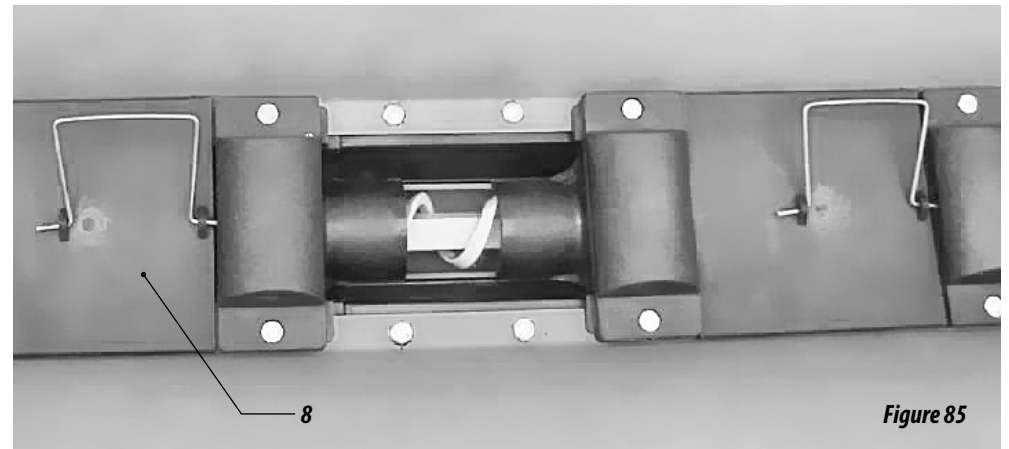

Figure 84

- 09 - Close the fertilizer inlets inside the hopper by putting a cover (8) on the rows that are not being used.



- 10 - Close the seed outlets with the cover (9), displacing it until it completely closes the seed distribution hopper (10).

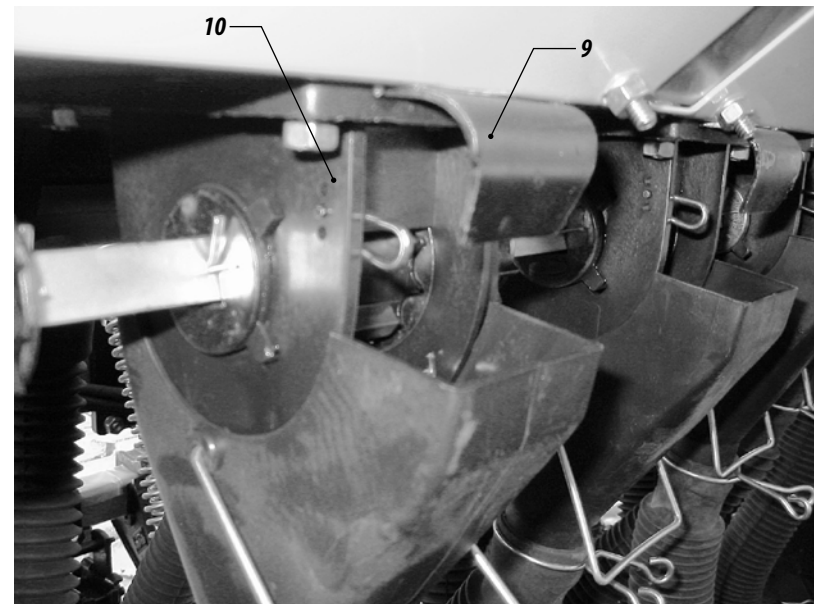
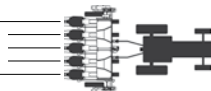

Figure 86

11 SEED RATE CONFIGURATIONS



SEED ADJUSTMENT

- 01 - Adjust the counters of the seed distribution hoppers for each type of seed and to prevent it from grinding or causing irregular planting
- 02 - The amount of seed is adjusted through the handle (2) shown in FIGURE 87.

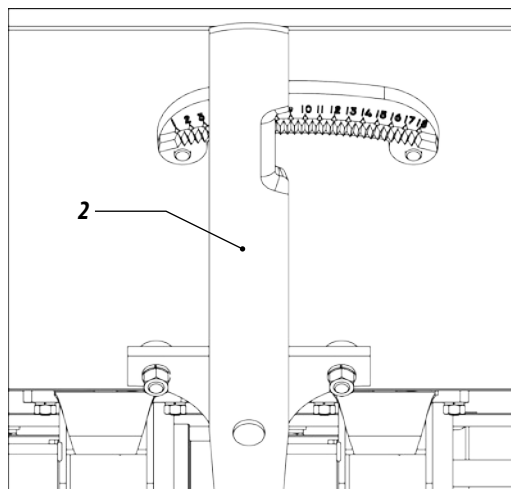

Figure 87

- 03 - Configure the seed type using the holes as describe bellow:

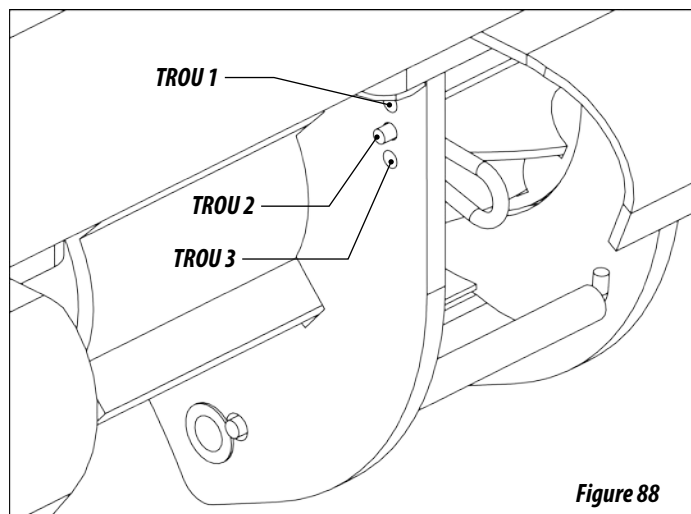

Figure 88

HOLE 1

- Put the pin of the counter (1) in hole 1 of the seed distributor to plant wheat, sorghum, barley, rye and similar seeds.

HOLE 2

- Put the pin of the counter (1) in hole 2 of the seed distributor to plant wheat, sorghum, barley, rye and similar seeds.

HOLE 3

- Put the pin of the counter (1) in hole 3 of the seed distributor to plant wheat, sorghum, barley, rye and similar seeds.

TABLE OF SEED QUANTITY

Crop	Number of seeds per linear meter	Grams of seeds per linear meter	Quantity of seeds per hectare (Kg)	Spacing (mm)
<i>Non-irrigated rice</i>	40 - 60	1,5 - 2,0	25 - 35	60 - 84
<i>Irrigated rice</i>	60	2,0	30 - 80	72 - 190
<i>Soybean</i>	25 - 40	-	60	145
<i>Wheat</i>	45 - 60	-	100 - 120	242 - 290
<i>Barley</i>	-	2,0	100 - 140	242 - 338
<i>Rye</i>	-	1,5	80	190
<i>Oat</i>	-	1,2 - 1,6	60 - 80	145 - 190
<i>Sunflower</i>	3 - 5	-	5 - 6	11 - 14
<i>Sorghum</i>	25	-	10 - 15	24 - 36
<i>Lupine</i>	8	-	-	-

Table 3

APPROXIMATE SEED DISTRIBUTION TABLE

Figure 89

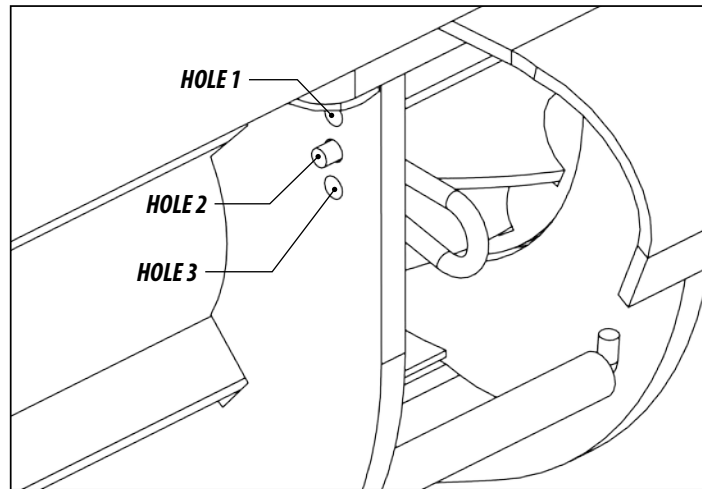

Table 4

		Seed Distribution in Grams / 100 meters																	
		Scale Number of Figure 90																	
		1	2	3	4	5	6	7	8	9	10	11	12	13	14	15	16	17	18
		Soybean: Average size 280 seeds for every 50 grams																	
Hole	1	-	-	51	119	170	238	289	357	425	510	578	680	748	816	901	986	1054	1139
	2	-	-	68	136	221	289	357	442	510	595	697	799	884	986	1071	1173	1258	1360
	3	-	-	85	170	255	340	425	510	595	697	816	918	1020	1139	1231	1343	1462	1564
		Rice: Average size 1590 seeds for every 50 grams																	
Hole	1	-	27	51	77	102	128	154	179	205	241	278	314	351	387	424	460	497	534
	2	-	30	62	92	123	153	184	215	246	286	326	366	406	446	485	525	565	605
	3	-	33	67	100	134	168	210	235	270	315	361	407	453	499	545	591	637	683
		Wheat: Average size 1020 seeds for every 50 grams																	
Hole	1	-	48	97	145	193	242	290	339	387	446	505	563	622	680	739	797	856	915
	2	-	55	110	166	221	276	332	387	442	517	591	666	740	815	890	964	1039	1113
	3	10	72	145	218	290	363	436	509	581	647	713	779	844	910	976	1045	1107	1173

- To obtain the result of Table 4 proceed as follows:
- 04 - Know the quantity of seeds per hectare, multiply by the spacing and divide by 100 linear meters.

EXAMPLE: Take a basis of 60 kg of soybean seed per hectare, with spacing of 600 mm in a distance of 100 linear meters.

Where:

Q = quantity of seeds (kg)

E = spacing between rows (mm)

D = 100 linear meters (m)

Formula: $\frac{Q \times E}{D}$

$\frac{60 \times 600}{100} = 360 \text{ grams}$

- 05 - The seed adjustment handle (1) should be adjusted to number 7 of the scale and in hole 1 of the seed counter.

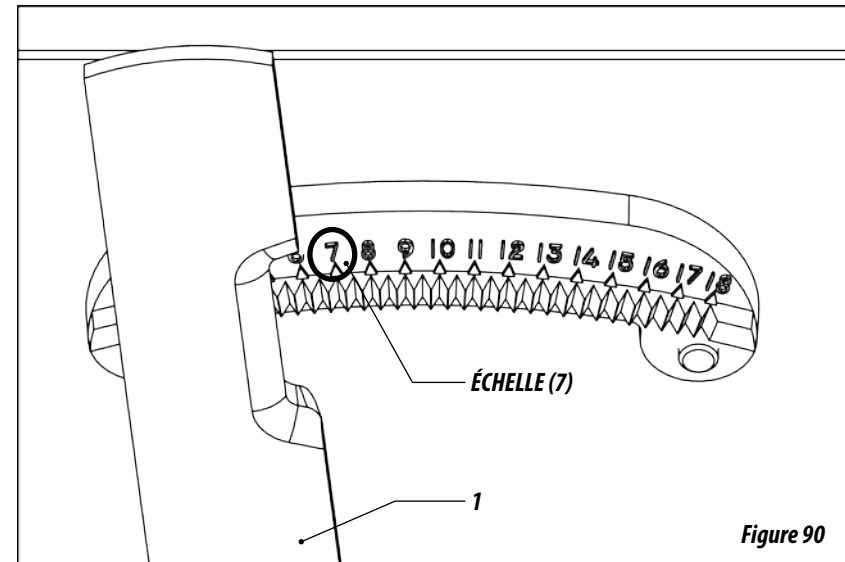

IMPORTANT

See how to conduct the practical test for seed and fertilizer on page 49.

ADJUSTMENT OF THE FINE SEED HOPPER (OPTIONAL)

- To adjust the distribution of fine seed, proceed as follows:
- 06 - Consult the fine seed distribution table below in the quantity desired per hectare.

Table 5

Fine Seed Distribution [kg/ha] with Spacing of 170 mm									
Type of Crop		Scale Number							
		0,5	1,0	1,5	2,0	2,5	3,0	3,5	4,0
GRASSES	Colonum	-	2,0	3,5	5,0	7,0	9,0	10,0	11,0
	Common brachiaria	-	5,0	7,0	10,0	14,0	17,0	20,0	22,0
	Brachiaria brizantha	-	3,0	5,0	7,0	10,0	14,0	17,0	20,0
	Millet	3,0	8,0	14,0	20,0	26,0	32,0	40,0	48,0

LEGUMES	Perennial soybean	3,5	10,0	17,0	24,0	32,0	41,0	50,0	59,0
	Alfalfa	4,0	12,0	20,0	29,0	38,0	47,0	56,0	65,0
	Gherkin	4,5	13,0	21,0	30,0	40,0	50,0	60,0	70,0
	Desmodium	3,8	12,0	19,0	26,0	34,0	43,0	52,0	61,0
	Clover	3,6	11,0	18,0	25,0	33,0	42,0	51,0	60,0

07 - **EXAMPLE:** To distribute 10 kg/ha of colonum seed with 170 mm spacing, turn the steering wheel (1) until the adjuster is on number 3.5 of the scale.

- Turning the steering wheel to "A" closes the scale.
- Turning the steering wheel to "B" opens the scale.

NOTE

Table of Approximate fine seed distribution per hectare for spacing of 170 mm.

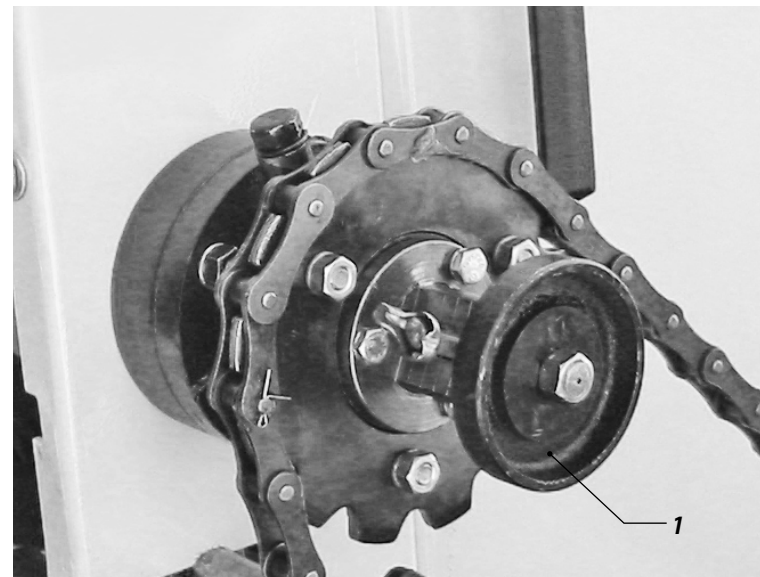

Figure 91

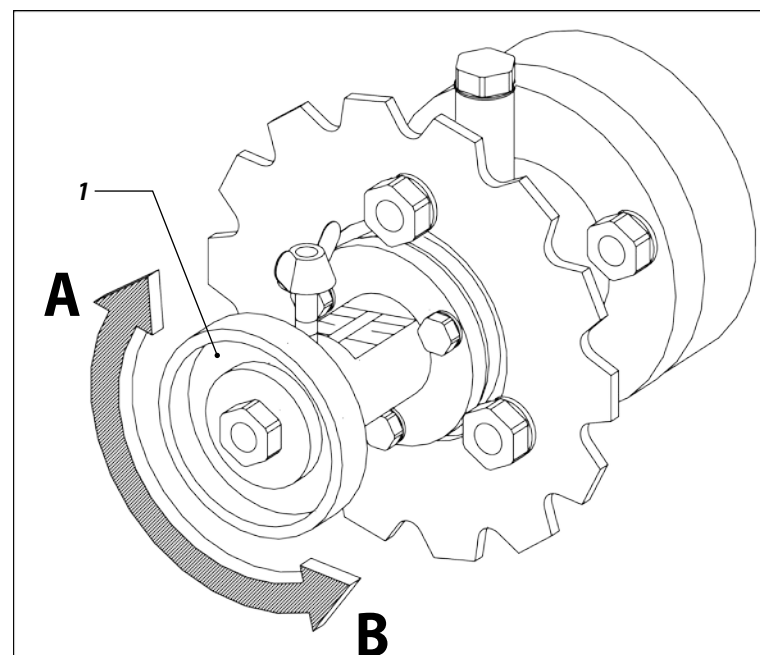
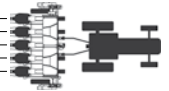

Figure 92



- 01 - The floating spiral fertilizer distribution system consists of a shaft located at the bottom of the fertilizer hopper, which starts to turn, enveloping the shaft with fertilizer and transporting the fertilizer to the outlets, dispensing the use of middle bearings.
- 02 - When the number of rows and desired spacing is determined, connect the hoses (1) to the fertilizer nozzle, connecting the pipes closest to the rows to avoid crossing or bending them.
- 03 - The outlets that are not used should be closed with a cover (2) inside the hopper.

Figure 93

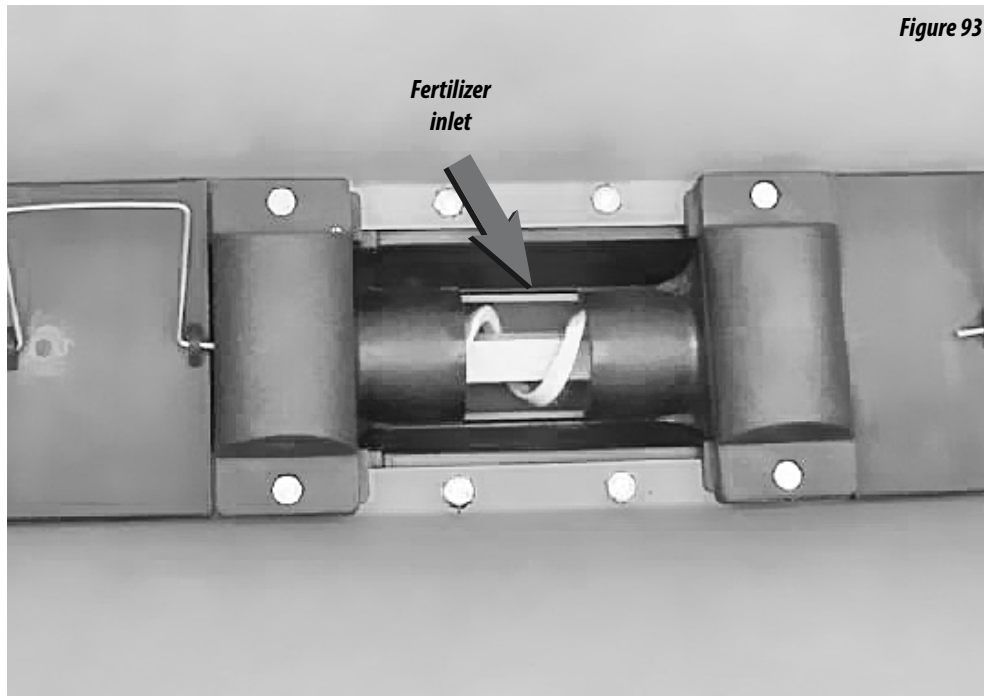
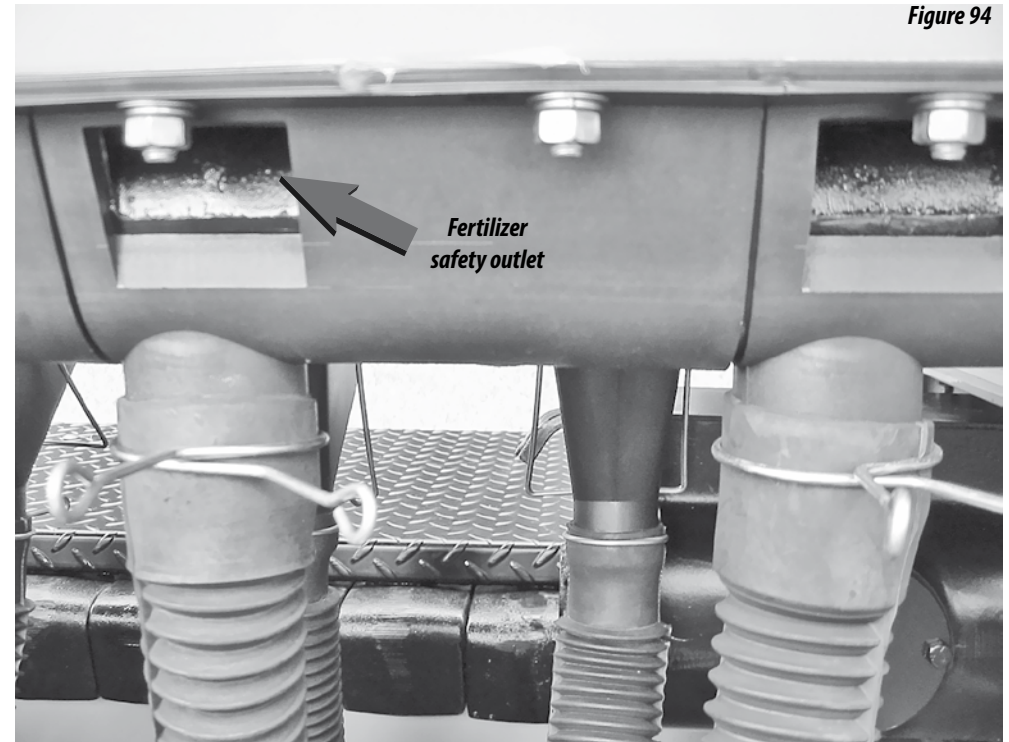

Figure 94



- 04 - The floating spiral fertilizer dosing system has several safety outlets that, when the fertilizer is placed in the doser and an outlet is obstructed, it will begin to leak through the safety outlets to guarantee the operation of the system without damaging it. In the case this should occur, clean the doser up to the nozzle located in the double disc because the obstruction may be due to roots, pieces of plastic and other objects.

IMPORTANT

Remove the covers and clean the outlets daily

SPEED BOX

- The seed drills are equipped with the Speed Box system, which operates the single adjustment distribution system, ensuring the change of rapid rotations:

01 - For fertilizer adjustment, select the desired quantity on the tables and check the corresponding number of the handles (1) in the COMBINATION column
Example: Combination A 6 in the position of detail **A** of **FIGURE 95**, indicates that the handle with letters should be in position "A" and the number handles must be in position "6".

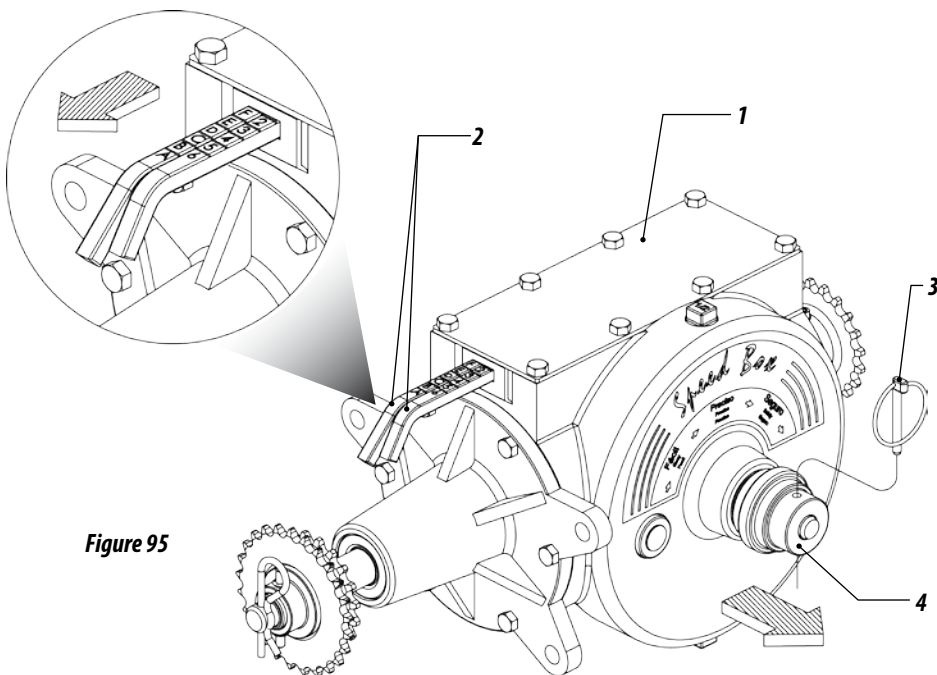

Figure 95

02 - To move the handles (1), remove the latch (2), pull the lever (3), then adjust the handles. After performing the combination, return the lever (3) and replace the latch (2).

CHANGE OF SIDE GEARS

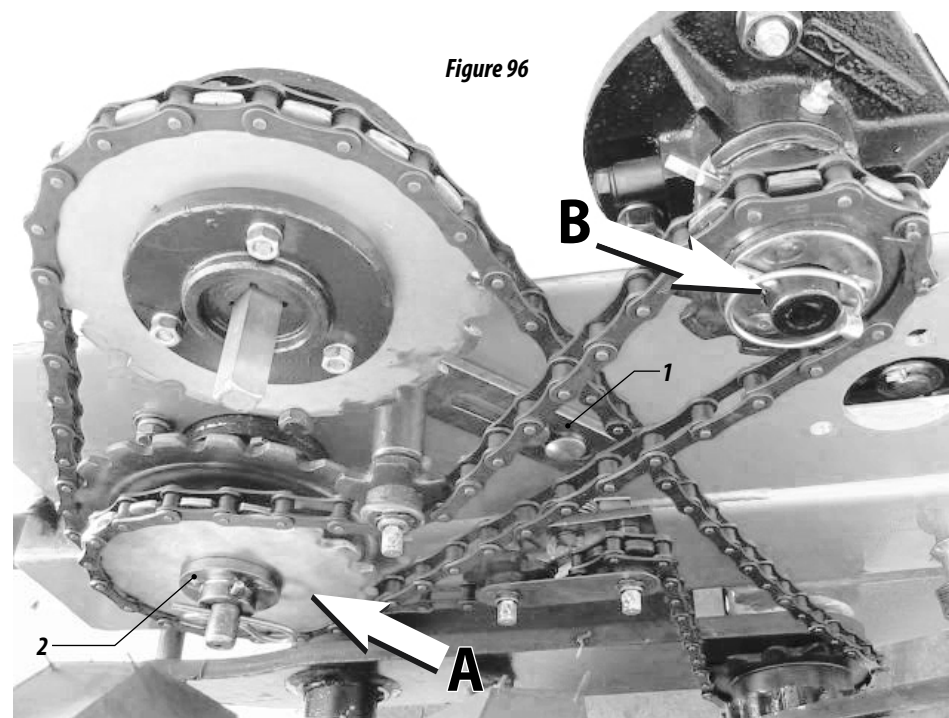

Figure 96

- 03 - Also check the change of outlet side gears of the Speed Box "A" and the fertilizer hopper "B".
- 04 - To change gears, remove the protection, loosen the screws of the stretcher (1), remove the latch (2) of the gears and proceed with changing them.
- 05 - Replace the latches (2), tighten the chain through the stretcher (1) and replace the protection.

⚠ ATENTTION

Do not operate the seed drill if the transmission protections are not duly fixed.

TABLE OF FERTILIZER DISTRIBUTION

Table 6

Table of Fertilizer Distribution of the SPD Speed Box Seed Drill [Kg/Ha]

Combination	Grams/ 50m	Ratchet shaft outlet gear										Speed Box inlet gear							
		9										17							
		Spacing between Rows																	
		170	250	300	350	400	450	500	550	600	650	700	750	800	850	900	950	1000	1050
A-6	36	43	30	25	21	18	16	15	13	12	11	11	10	9	9	8	8	7	7
B-6	41	49	33	28	24	21	18	17	15	14	13	12	11	10	10	9	9	8	8
C-6	47	56	38	32	27	24	21	19	17	16	15	14	13	12	11	11	10	9	9
A-5	47	54	37	31	26	23	21	18	17	15	14	13	12	12	11	10	10	9	9
D-6	56	65	44	37	32	28	25	22	20	18	17	16	15	14	13	12	12	11	11
B-5	52	61	42	35	30	26	23	21	19	17	16	15	14	13	12	12	11	10	10
4-A	56	65	44	37	32	28	25	22	20	18	17	16	15	14	13	12	12	11	11
C-5	59	70	47	40	34	30	26	24	22	20	18	17	16	15	14	13	12	12	11
E-6	68	78	53	44	38	33	30	27	24	22	20	19	18	17	16	15	14	13	13
B-4	63	73	50	42	36	31	28	25	23	21	19	18	17	16	15	14	13	12	12
A-3	65	76	52	43	37	32	29	26	23	22	20	18	17	16	15	14	14	13	12
D-5	70	81	55	46	40	35	31	28	25	23	21	20	18	17	16	15	15	14	13
C-4	72	84	57	47	41	36	32	28	26	24	22	20	19	18	17	16	15	14	14
B-3	72	85	58	48	42	36	32	29	26	24	22	21	19	18	17	16	15	15	14
A-2	74	87	59	49	42	37	33	30	27	25	23	21	20	18	17	16	16	15	14
A-1	83	98	66	55	47	42	37	33	30	28	26	24	22	21	20	18	17	17	16
B-1	95	110	75	62	53	47	42	37	34	31	29	27	25	23	22	21	20	19	18
C-2	95	112	76	63	54	47	42	38	35	32	29	27	25	24	22	21	20	19	18
D-3	97	114	77	65	55	48	43	39	35	32	30	28	26	24	23	22	20	19	18
E-4	99	117	80	66	57	50	44	40	36	33	31	28	27	25	23	22	21	20	19
C-1	106	126	85	71	61	53	47	43	39	36	33	30	28	27	25	24	22	21	20
D-2	110	130	89	74	63	55	49	44	40	37	34	32	30	28	26	25	23	22	21
F-5	104	122	83	69	59	52	46	42	38	35	32	30	28	26	24	23	22	21	20
E-3	117	137	93	77	66	58	52	46	42	39	36	33	31	29	27	26	24	23	22
D-1	124	146	100	83	71	62	55	50	45	42	38	36	33	31	29	28	26	25	24
E-2	133	156	106	89	76	66	59	53	48	44	41	38	35	33	31	30	28	27	25
F-4	124	146	100	83	71	62	55	50	45	42	38	36	33	31	29	28	26	25	24
E-1	149	176	120	100	85	75	66	60	54	50	46	43	40	37	35	33	31	30	28
F-3	146	171	116	97	83	73	65	58	53	48	45	42	39	36	34	32	31	29	28
F-2	167	195	133	111	95	83	74	66	60	55	51	47	44	42	39	37	35	33	32
F-1	187	220	149	125	107	93	83	75	68	62	57	53	50	47	44	42	39	37	36

TABLE OF FERTILIZER DISTRIBUTION

Table 7

Table of Fertilizer Distribution of the SPD Speed Box Seed Drill [Kg/Ha]

Combination	Grams/ 50m	Ratchet shaft outlet gear										Speed Box inlet gear							
		Spacing between Rows																	
		170	250	300	350	400	450	500	550	600	650	700	750	800	850	900	950	1000	1050
A-6	133	155	105	88	75	66	59	53	48	44	41	38	35	33	31	29	28	26	25
B-6	149	174	118	99	85	74	66	59	54	49	46	42	39	37	35	33	31	30	28
C-6	169	199	135	113	97	85	75	68	62	56	52	48	45	42	40	38	36	34	32
A-5	164	194	132	110	94	82	73	66	60	54	51	47	44	41	39	37	35	33	31
D-6	198	232	158	132	113	99	88	79	72	66	61	56	53	49	46	44	42	39	38
B-5	185	218	148	123	106	93	82	74	67	62	57	53	49	46	44	41	39	37	35
4-A	198	232	158	132	113	99	88	79	72	66	61	56	53	49	46	44	42	39	38
C-5	212	249	169	141	121	106	94	85	77	71	65	60	56	53	50	47	45	42	40
E-6	236	279	190	158	135	118	105	95	86	79	73	68	63	59	56	53	50	47	45
B-4	223	261	178	148	127	111	99	89	81	74	68	63	59	56	52	49	47	44	42
A-3	230	271	184	154	132	115	102	92	84	77	71	66	61	58	54	51	49	46	44
D-5	248	290	197	165	141	123	110	99	90	82	76	71	66	62	58	55	52	49	47
C-4	254	299	203	169	145	127	113	102	92	85	78	73	68	63	60	56	53	51	48
B-3	259	305	207	173	148	130	115	104	94	86	80	74	69	65	61	58	55	52	49
A-2	263	310	211	176	150	132	117	105	96	88	81	75	70	66	62	59	55	53	50
A-1	297	348	237	197	169	148	132	118	108	99	91	85	79	74	70	66	62	59	56
B-1	333	392	267	222	190	167	148	133	121	111	103	95	89	83	78	74	70	67	63
C-2	338	398	271	226	193	169	150	135	123	113	104	97	90	85	80	75	71	68	64
D-3	347	407	276	230	197	173	154	138	126	115	106	99	92	86	81	77	73	69	66
E-4	356	418	284	237	203	178	158	142	129	118	109	102	95	89	84	79	75	71	68
C-1	380	448	305	254	218	190	169	152	138	127	117	109	102	95	90	85	80	76	73
D-2	396	465	316	263	226	197	176	158	144	132	122	113	105	99	93	88	83	79	75
F-5	371	436	296	247	212	185	165	148	135	123	114	106	99	93	87	82	78	74	71
E-3	414	488	332	276	237	207	184	166	151	138	128	118	111	104	98	92	87	83	79
D-1	443	523	355	296	254	222	197	178	162	148	137	127	118	111	105	99	94	89	85
E-2	475	558	379	316	271	237	211	190	172	158	146	135	126	118	112	105	100	95	90
F-4	443	523	355	296	254	222	197	178	162	148	137	127	118	111	105	99	94	89	85
E-1	533	627	427	355	305	267	237	213	194	178	164	152	142	133	125	118	112	107	102
F-3	518	610	415	246	296	259	230	207	188	173	159	148	138	130	122	115	109	104	99
F-2	592	697	474	395	338	296	263	237	215	197	182	169	158	148	139	132	125	118	113
F-1	666	784	533	444	381	333	296	267	242	222	205	190	178	167	157	148	140	133	127

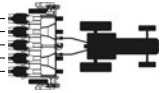

- 01 - Determine the spacing between rows and the quantity of fertilizer to be distributed per bushel or hectare.

EXAMPLE: Seed drill with spacing of 170 mm to distribute 500 kgs of fertilizer per Ha using the formula below:

$$\text{Formula: } X = \frac{E \times Q}{A} \times D$$

Formula data:

- E** = Spacing between rows (mm)
Q = Quantity of fertilizer to be distributed
A = Area to be fertilized (m²)
D = Distance of 50 meters (test)
X = Grams of fertilizer in 50 meters

$$\text{Resolves: } X = \frac{170 \times 500}{10.000} \times 50$$

$$X = 8,50 \times 50 = 425 \text{ grams}$$

$$X = 425 \text{ grams in 50 meters per row}$$

PRACTICAL TEST TO CHECK THE QUANTITY OF FERTILIZER AND SEED DISTRIBUTION

- 01 - For greater distribution precision for both seed and fertilizer, conduct the test of quantity to be distributed at the planting site as the condition for each land is different.
- 02 - Always check and keep the seed drill tires calibrated at 18 lb / inch² with water and 22 lb / inch² without water for each one.
- 03 - Mark the distance for testing on the table, and 50 linear meters was chosen.
- 04 - Supply the seed drill hoppers at least up to half. Run some meters outside the test area in order for the seeds and fertilizer to fill up the dosers.
- 05 - Seal the seed nozzle outlet and put containers to collect on the fertilizer outlets. Move the tractor in the demarcated area, always in the same speed used for planting.
- 06 - After running the demarcated space, remove the seal from the seed nozzle and collect them in order to count and weigh the collected fertilizer. If necessary, increase or reduce the quantity of fertilizer or seed.
- 07 - Do the same procedure as a #6 for calibrating the seed metering.

ADJUSTMENT OF ROW MARKERS

- 08- Adjustment of row markets is important for obtaining planting with uniform spacing, making the row on the extreme end of the seed drill to be in the same spacing as the last planted row, thus facilitating future operations.
- 09- The spacing between rows, the number of rows to be used in the operation and the front gauge of the tractor must be known in order to adjust the row markers
- 10- Use the formula in the example below.

EXAMPLE: For planting with 5 rows on the seed drill, spacing of 0.90 m and front gauge of the tractor with 1.43 m, determine:

Formula: $D = \frac{E \times (N+1)}{2} - B$

Resolves: $D = \frac{0,90 \times 6}{2} - 1,43$

$D = 1,98 \text{ meters}$

Where:

- E = Spacing between rows
- N = Number of rows of the seed drill
- B = Front gauge of the tractor
- D = Row marker distance

- 11- Adjust the row marker disc with 1.98 m to the center of the first planting row.

ADJUSTMENT OF ROW MARKER DISC

- 12- The row marker disc (1) has angular adjustment to facilitate the demarcation work on the ground. This adjustment requires loosening the nut (2) and turn the disc to the desired position.

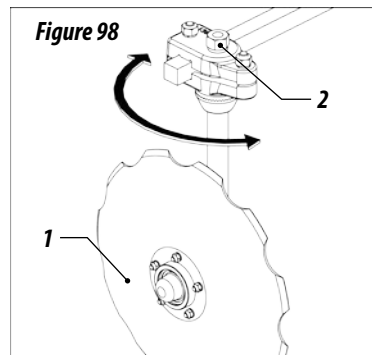

Figure 98

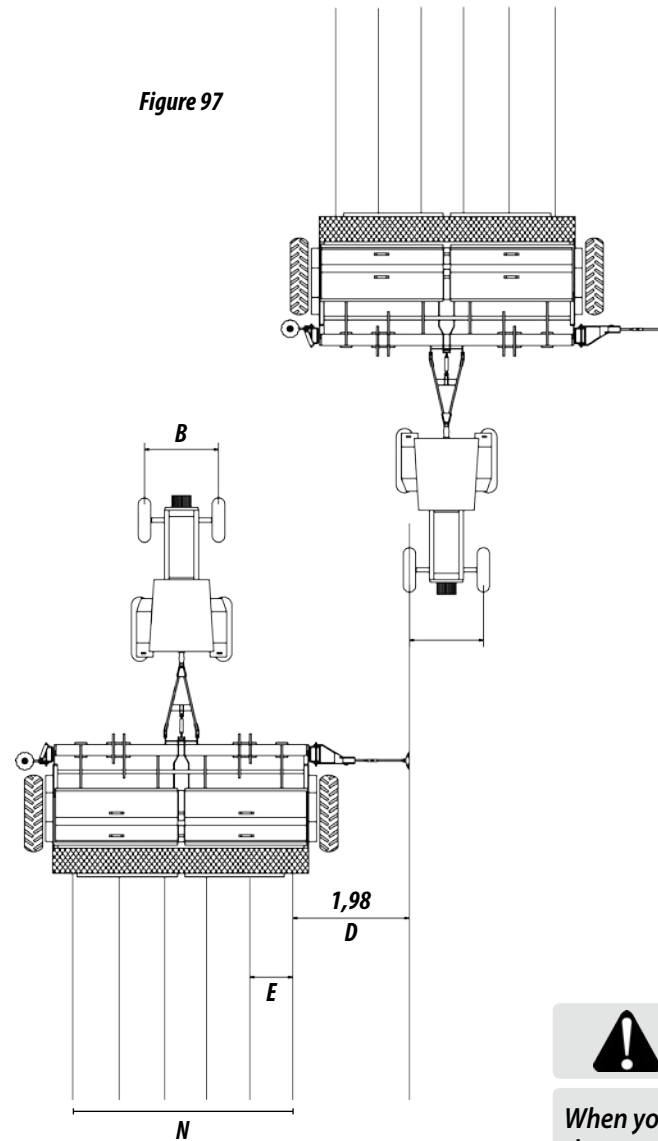

Figure 97

ATENTTION

Adjustment of the marker only for large seeds with spacing above 415 mm.

ATENTTION

When you change the tractor, calculate the row marker configuration again.

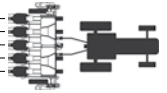

PRESSURE OF THE SPRINGS

01 - Depth adjustment of the seed drill is performed through the pressure of the springs and piston limiters.

- The pressure of the springs depend on the conditions of the soil and the seed drill system (conventional, minimum or direct) that enables different adjustments, observing the combinations of springs in the following way:

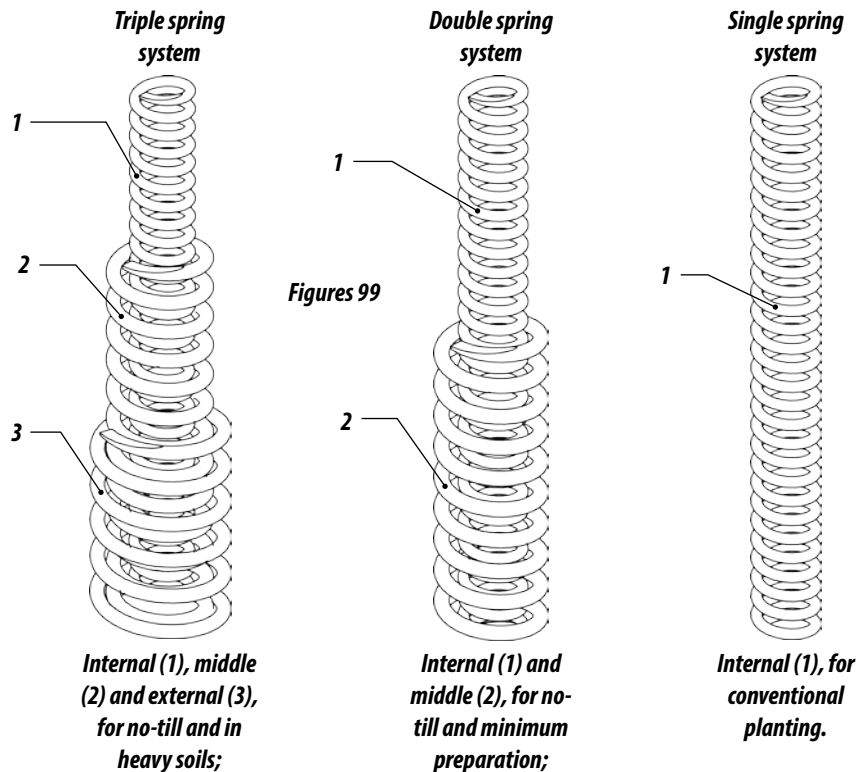

NOTE

Excess pressure on the springs causes the equipment to be raised due to the reaction of the soil to penetration.

02 - Loosen the bushing (4) and fix it to the rod in order to release the descent of the row. Fix the bushing about 5 cm over the rod bracket (7).

03 - Loosen the bushing (5) and fix it upwards in order to provide the springs (6) with more pressure for better penetration of the row.

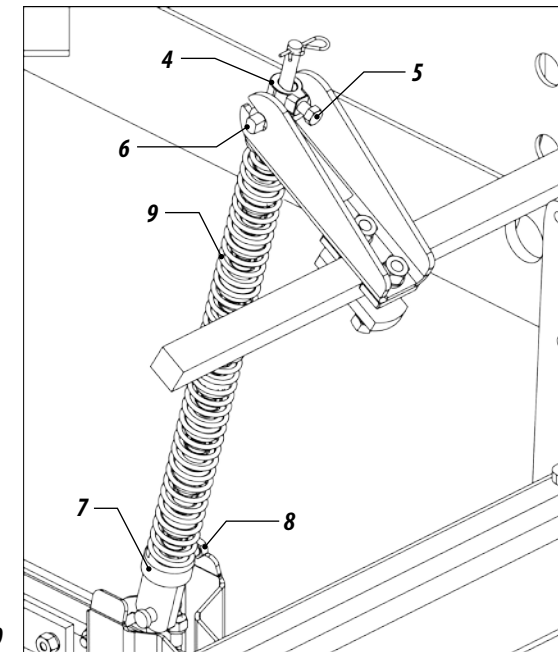

Figure 100

IMPORTANT

The equipment's penetrating capacity is obtained by adequate and conjugated pressure of the active elements. During planting in lands subjected to soil moisture variations or other factors, check the working depth several times.

LIMITERS

04 - The rod guide are used for control comes out movement in hydraulic cylinder, in order to press the blade support providing ideal downforce on the springs. The rod guide are available in this configurations:

02 rod guide
de ø 42 x 49,5mm

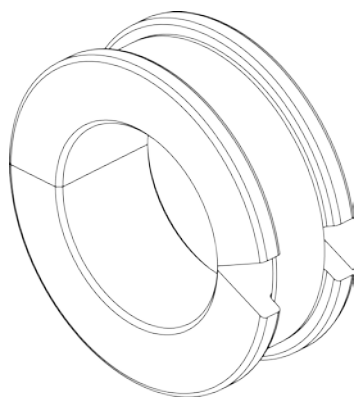

Code
53480500098

Figure 101

02 rod guide
de ø 42 x 25mm

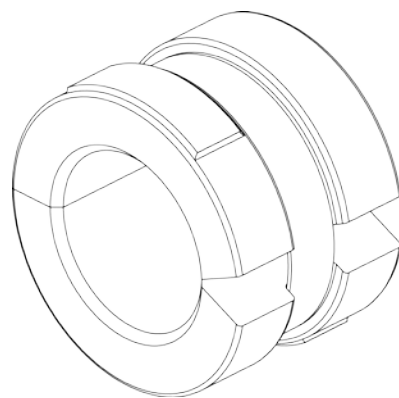

Code
53480500063

IMPORTANT

You can set the rod guide in these configurations: 25, 50 e 75 mm on the come out movement of rod.

ATTENTION

To avoid damage on the frame bolt on the rod guide in the both side of the seed drill.

DEPTH CONTROL RIM

05 - The depth control rim (1) is mounted on the double disc (2) and is used to determine the depth of fertilizer and seed position.

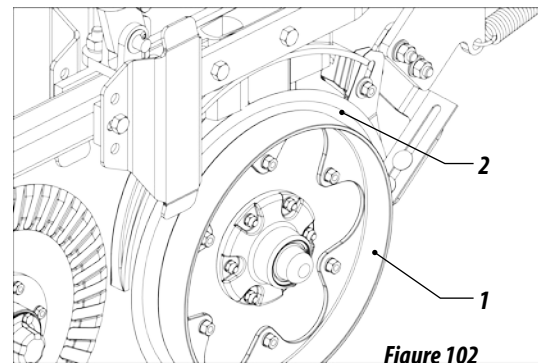

Figure 102

ATTENTION

The depth control rim is available in three models:

Rim 20mm

Rim 40mm

Rim 55mm

ADJUSTMENT OF "V" COMPACTION WHEEL

06 - The V-shaped compression wheel (#1) was designed to close the furrow by the side, inserting the soil over the seed after the delivery. This procedure avoid the high compression of soil and provide good development of the plant. To adjust the V-shaped compression wheel follow the instructions below:

- **INCREASE DOWNFORCE:** remove the hair pin (#2) pull in the lever (#3) and lock again.
- **DECREASE THE DOWNFORCE:** remove the hair pin (#2) push the lever (#3) and lock again.

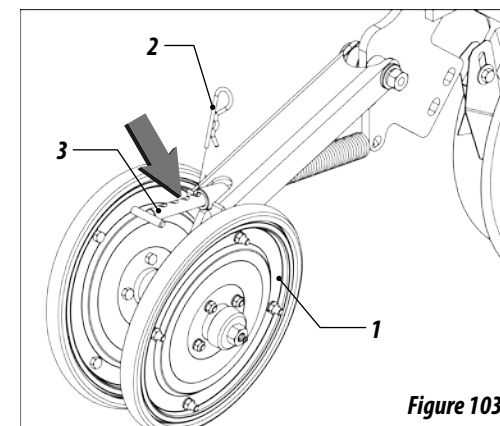

Figure 103

ATTENTION

Make the same adjustment for all row unit, considering the soil condition in order to regular germination of the plants.

ADJUSTMENT OF IRON COMPACTION WHEEL (OPTIONAL)

- 07 - The cast iron compression wheel was designed to close the furrow, inserting the soil over the seed after the delivery. This procedure avoid the high compression of soil and provide good development of the plant.
- 08 - To adjust the cast iron compression wheel (#2) loosen the spring (#2), changing the spring to the next or previous support (#3) in accordance with the soil conditions required.

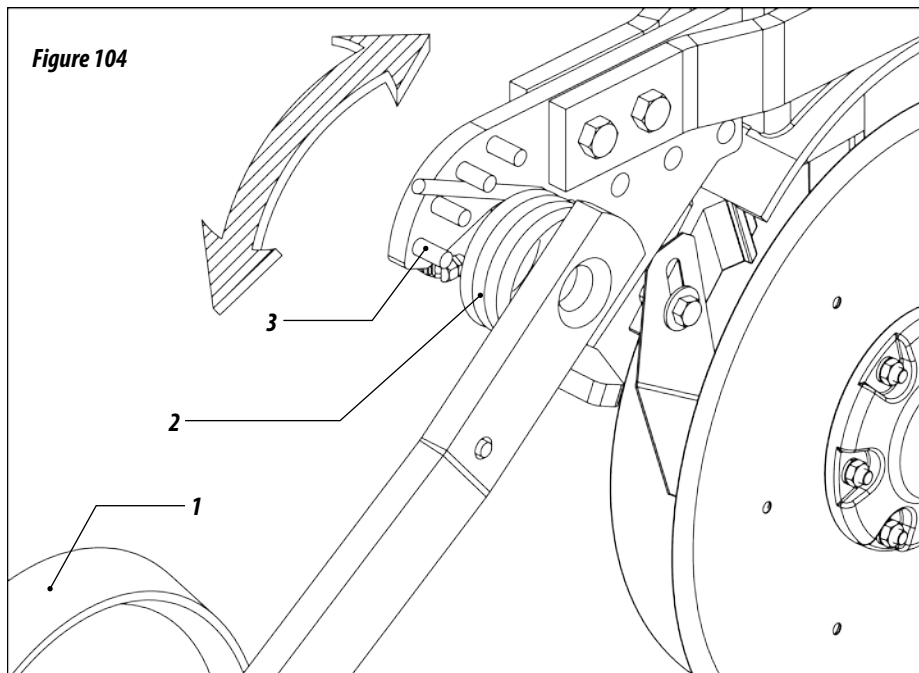

- 09 - To move the cast iron wheel (#1) on the horizontal position, change the position of the washer (#4) until get the desired position.
- 10 - To adjustment of the cleaner (#5) on the horizontal position, loosen the nut (#6) moving the bolt (#7) until the cleaner touch the rim surface (#1).
- 11 - To adjust the cleaner (#5) on the vertical position, loosen the bolt (8) moving until the desired position.

Figure 105

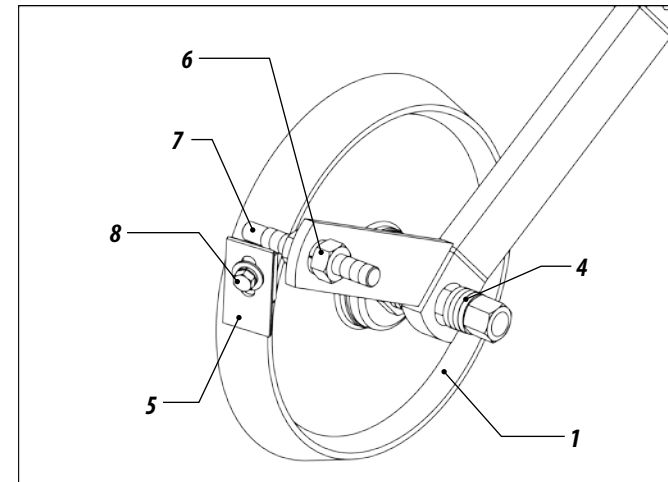

- 12 - To adjust the cast iron wheel height, loosen the bolt (#9), washer and nuts (#10), setting the wheel support (#11) on the desired height then tighten again.

ATTENTION

Make the same adjustment for all row unit, considering the soil condition in order to regular germination of the plants

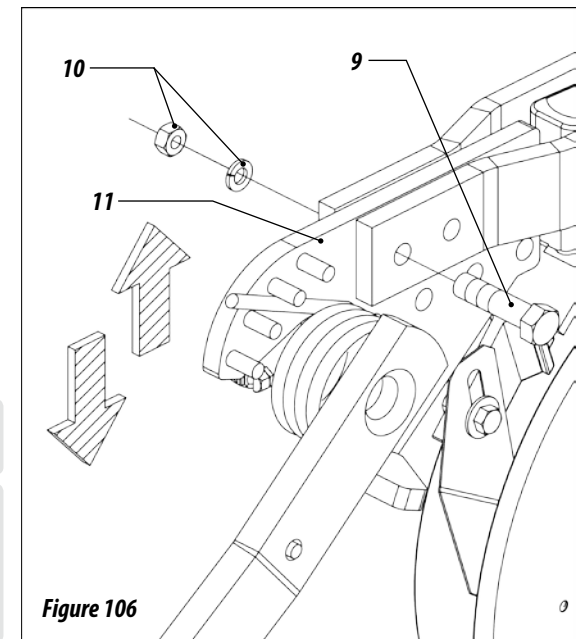

Figure 106

ADJUSTMENT OF COULTER BLADE RIPPLED OR SMOOTH (OPTIONAL)

- To adjust the depth of rippled coultter blade (#1) follow this instruction:

13- Remove the lock (#1), the pin (#2), adjust the height of the support (#3) and attach the support again.

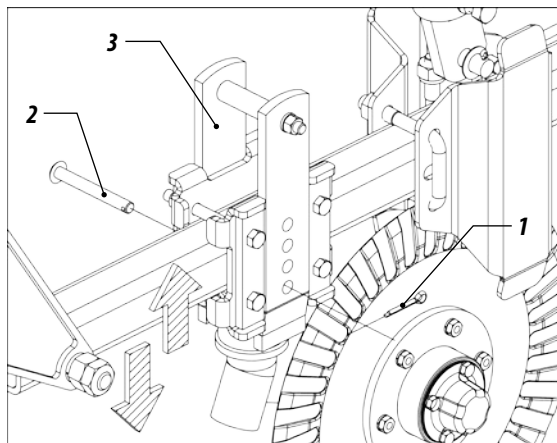

Figure 107

- To move the coultter blade in horizontal position follow this instruction:

14- Loosen the bolt (#4), washer and nuts (#5), move the disc until the desired position then attach again.

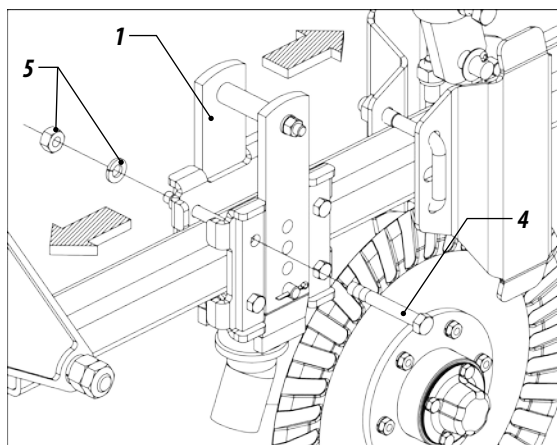

Figure 108



ATTENTION

Perform the same adjustment on all the cutting discs.

ADJUSTMENT OF ANGLED GAUGE WHEELS (OPTIONAL)

- Angled gauge wheels (#1) behind seed opener close the seed trench created by openers. The gauge wheels firm soil on each side of seed, directly over seed. Adjustable angle permits proper closing of seed trench.

15- The gauge wheels (#1) are journaled in an axle designed for depth control. To change angle, remove nut (#3) turning the axle (#2) until get the desired angle.

16- The depth adjustment is done by each wheel (#1) (smooth or convex), using the bolt (#4).

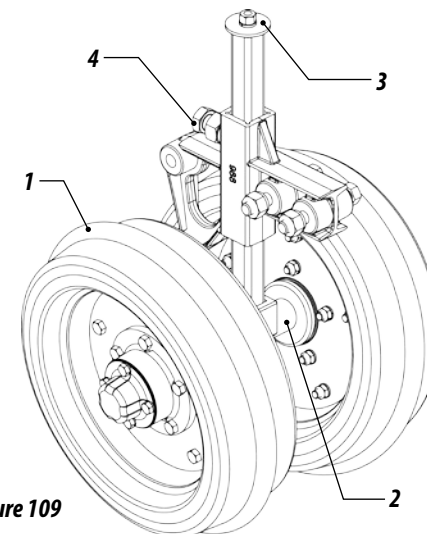
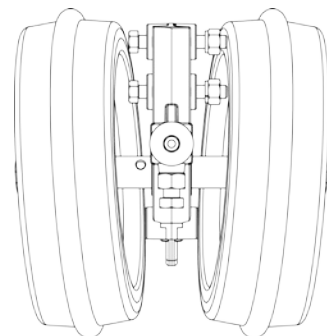
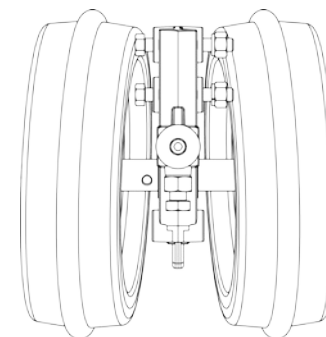

Figure 109

POSITION OF GAUGE WHEEL ANGLE



Position of gauge wheel
Angle totally closed (Less soil over the seed)



Position of gauge wheel
Angle totally opened (More soil over the seed)

Figure 110

ADJUSTMENT OF COMPRESSION WHEEL - OPTIONAL

- 17- The compaction wheel is used to press the furrow causing the soil to be immediately placed over the seed, avoiding excess compaction, and facilitating plant germination.
- 18- To adjust the wheel (1), loosen the locknut (2), the screw (3) and move the wheel to the desired position, then retighten the screw and locknut, figure 111.

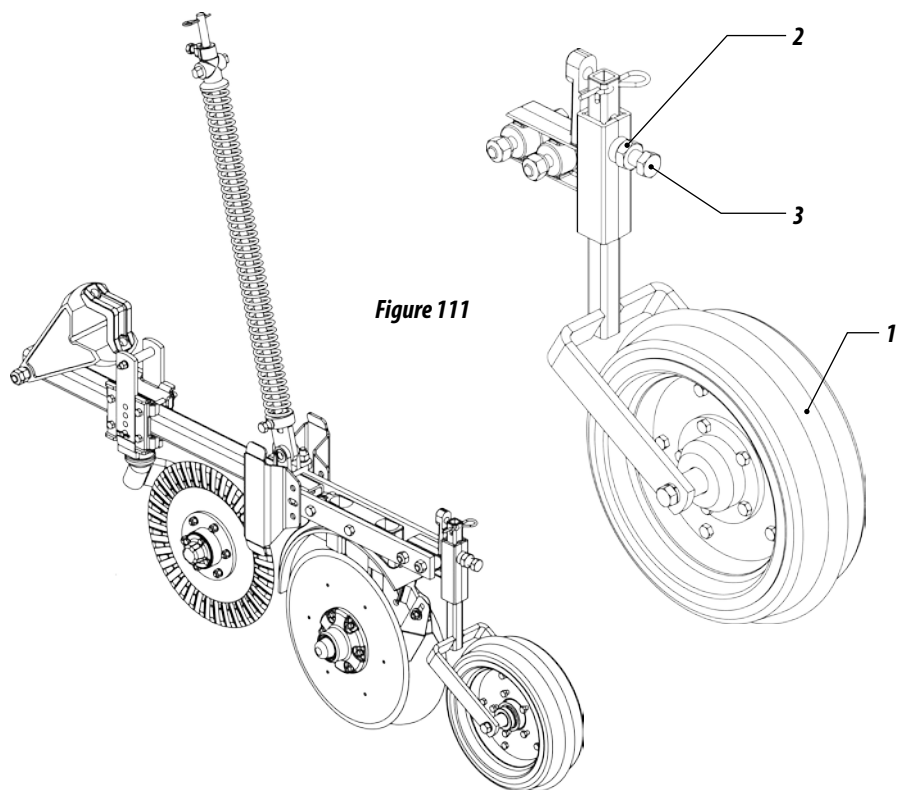

Figure 111

ATTENTION

Perform the same adjustment on all the compaction wheels, considering the type of soil, seed and planting depth in order to not affect the free emergency of the plants.

COUNTERWEIGHTS

- The extra-weight (#1) are installed on the rear frame (#2) of seed drill. It provide a better soil disruption when you install a extra-weight, the seed drill gain 15,5kg on the weight. You can install or remove it easily following the instructions below:

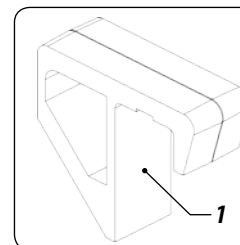

Models	Number of Counterweights	Total (Kg)
SPD 3000	16	248
SPD 4000	20	310
SPD 5000	24	372

Table 8

- You can install or remove it easily following the instructions below:
- 19- Loosen the bolt (#3), washer and nut (4), remove the catwalk sheet metal (#5), remove the bolt (#6), washers nuts (#7) and the sheet (#8).
- 20- Install one extra-weight in each side and other on the center, repeat this procedure until get the amount desired, and then mount the catwalk again, figure 112.

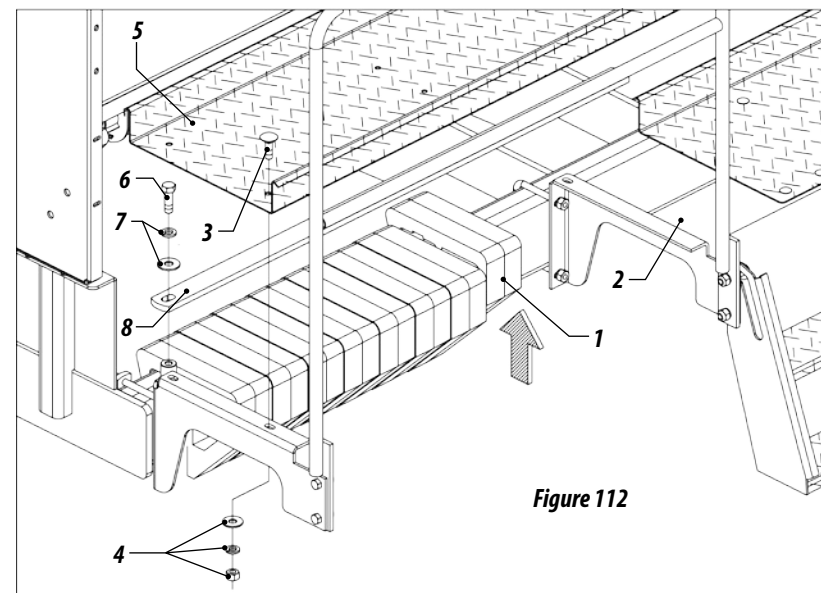
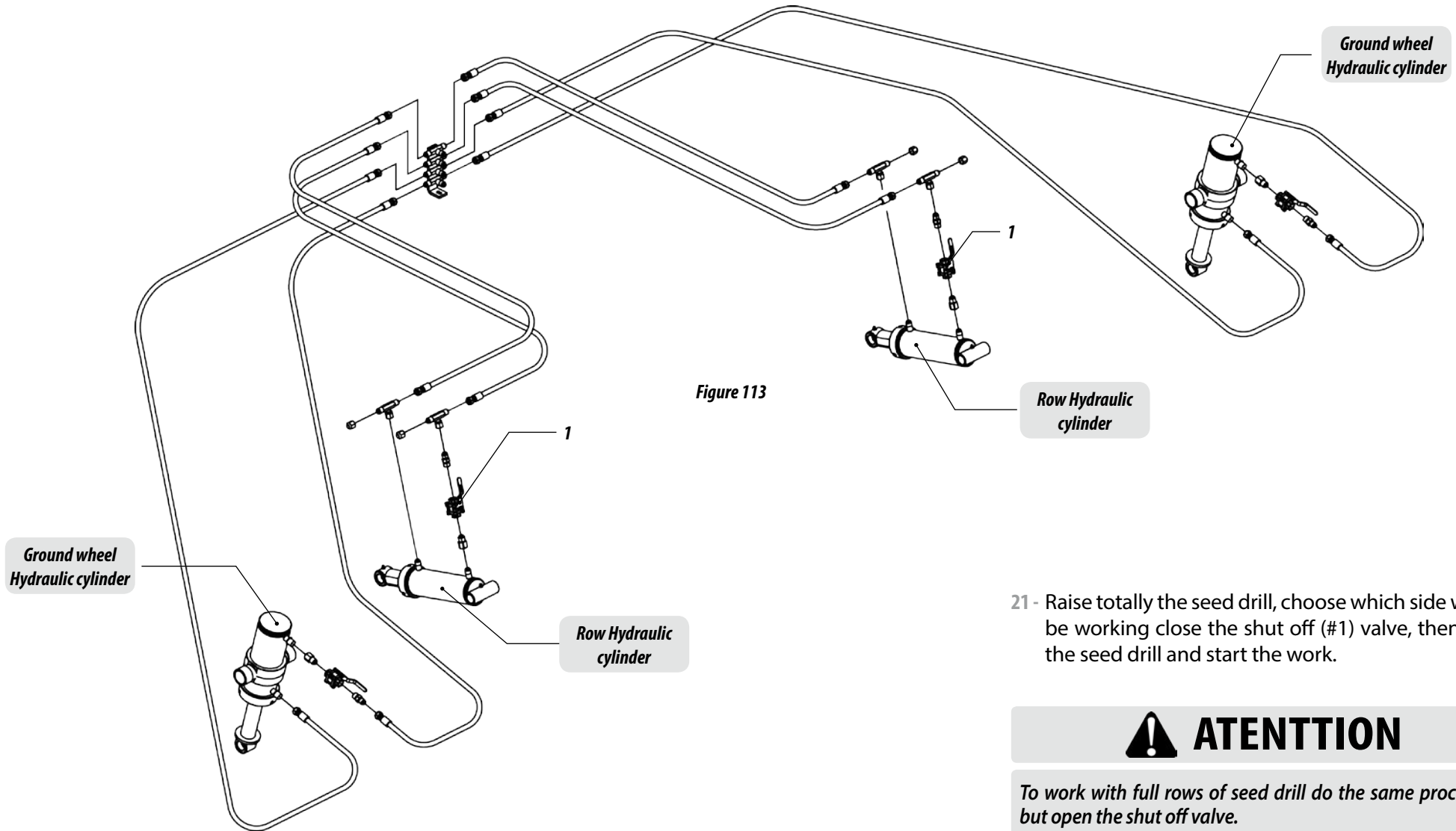

Figure 112

FINISHER SYSTEM

- The seed drill is equipped with the finisher system, so you can use half the machine, to configure it follow the instruction below:



21 - Raise totally the seed drill, choose which side will not be working close the shut off (#1) valve, then lower the seed drill and start the work.

! ATENTION

To work with full rows of seed drill do the same procedure, but open the shut off valve.

FIXATION AND JOINT SYSTEM OF THE WHEELS

- 22 - The fixation and joint system (1) of the wheels prevents pressure of the springs on the soil, enabling them to oscillate and accompany the irregularities of the land, preventing the interruption of fertilizer and seed distribution.
- 23 - In order for the tires to oscillate, remove the pin (2) from both sides of the equipment in order to free the system.

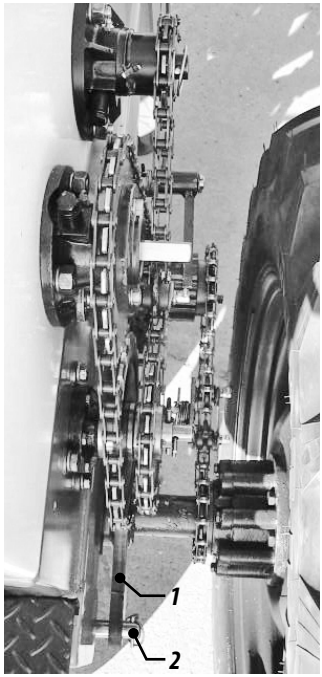

Figure 114



Figure 115

- 24 - During the dry season and on compacted lands, when the seed drill is complete with all the planting rows, the spring tend to raise the equipment; in this case, put all the counterweights that accompany the equipment, put water in the tires and fix the joint systems using the pin (2) so that the tires start to act as a ballast and then close the counter (3) to interrupt the flow of oil to the side pistons.

SINGLE SEED HOPPER

- 25 - To transform the single seed hopper, remove the plates (1) to enable flow of seed between two hoppers.
- 26 - Put the covers (2) of the fertilizer nozzles. This will become the single hopper for seeds, giving the equipment greater autonomy.

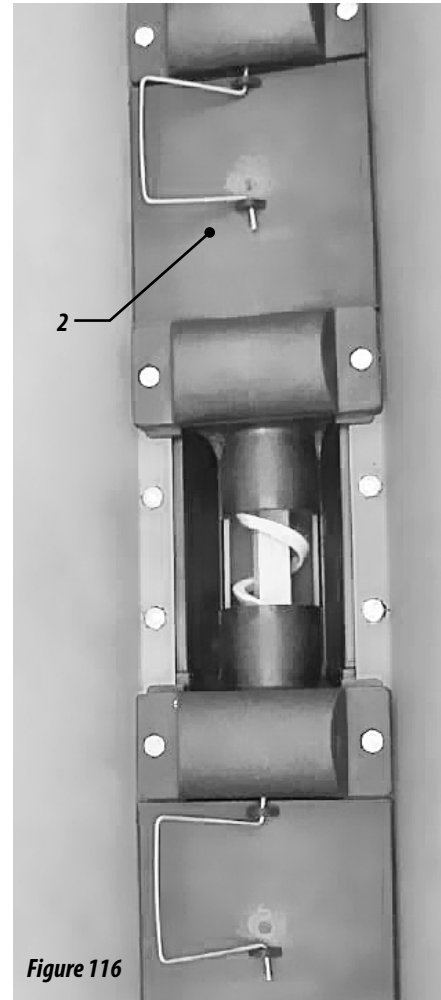

Figure 116

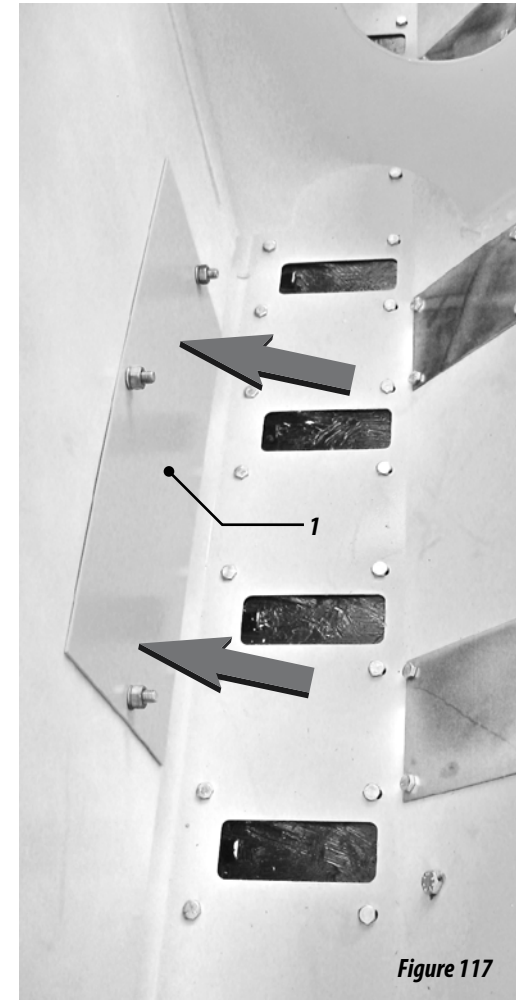
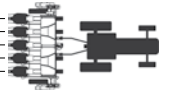

Figure 117

15 NO-TILL KIT (CPD) - OPTIONAL



- The CPD is an optional assembly for the equipment SPD 3000, 4000 and 5000 with which it is possible to transform the continuous flow seed drill (fine grain distribution from spiral rotor) into a precision seed drill (distribution of coarse grains from the horizontal disc distribution system).

- **The CPD Kit consists of:**

- 01 - Cutting disc of 16" (1);
- 02 - Double non-central discs for fertilizers with individual cleaners and internal scraper (2);
- 03 - Sharp furrower with removable nozzle
- 04 - Double non-central discs for seeds with individual cleaners (4);
- 05 - Oscillating depth wheel with only one point of support (5) or fixed (6);
- 06 - Pressure and alignment compaction wheel with angular adjustments (7);
- 07 - Horizontal seed distributor (8).

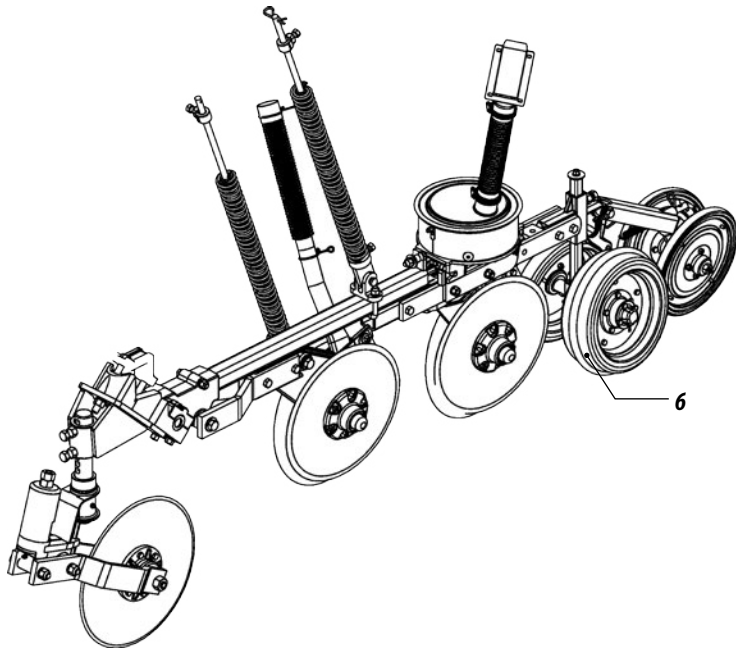
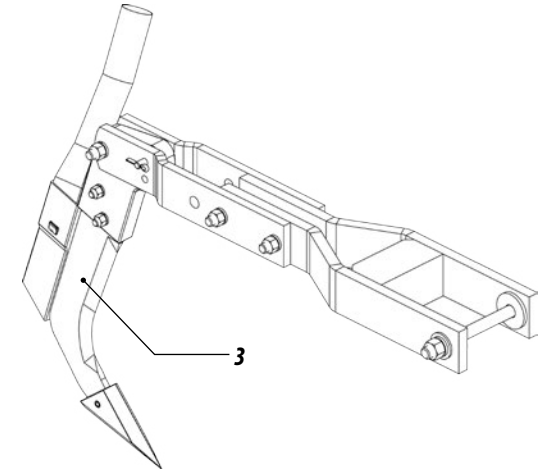

Figures 118

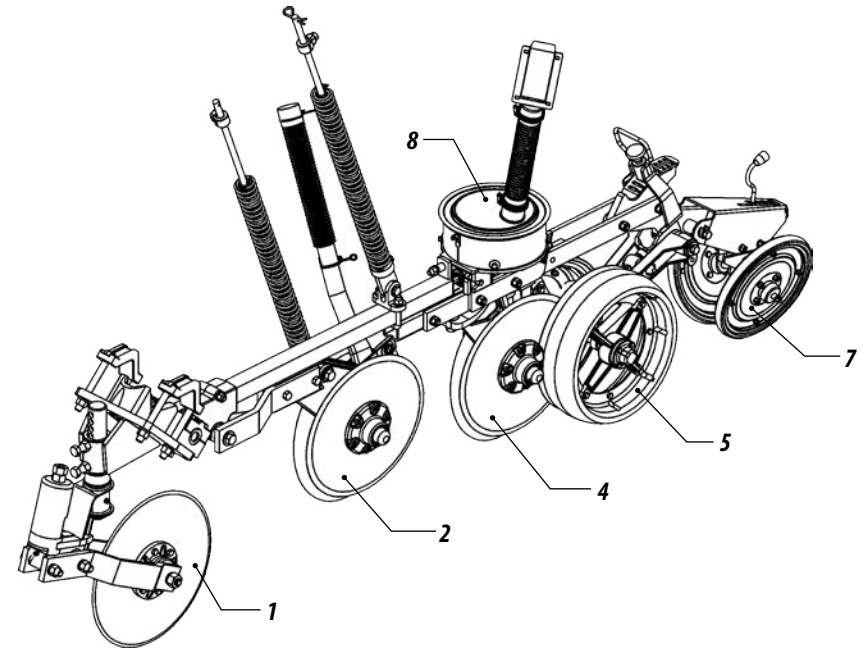

CPD MOUNTING - NO-TILL KIT (CPD) - OPTIONAL

- 08 - Fix the hub (2) to the stiffener (1) with screws (3), washers and nuts (4).
- 09 - Mount the complete stretcher (5) on the stiffener with washer and nut (6) and also the middle hub (7) with the screws (8), washers and nuts(9), insert the chain (10) between the hub gears (2) and (7), passing through the stretcher (5).
- 10 - The chain (11) will be mounted on the hub gear (7), passing through the Speed Box and also the ratchet gear, which are from the conventional transmission.
- 11 - Fix the CPD row (12) to the seed drill stiffener bar in the desired spacing, according to the crop to be planted.

- 12 - Insert the shaft (13) into the hub (2), passing through the hub of the rows (12), and fixing it with the latch (14).
- 13 - Fix the seed nozzles (15) to the rear outlets of the seed hopper of the seed drill, figure 120.

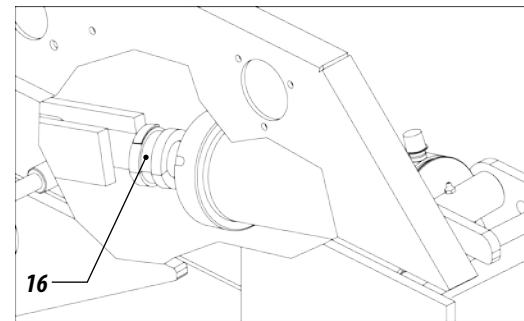
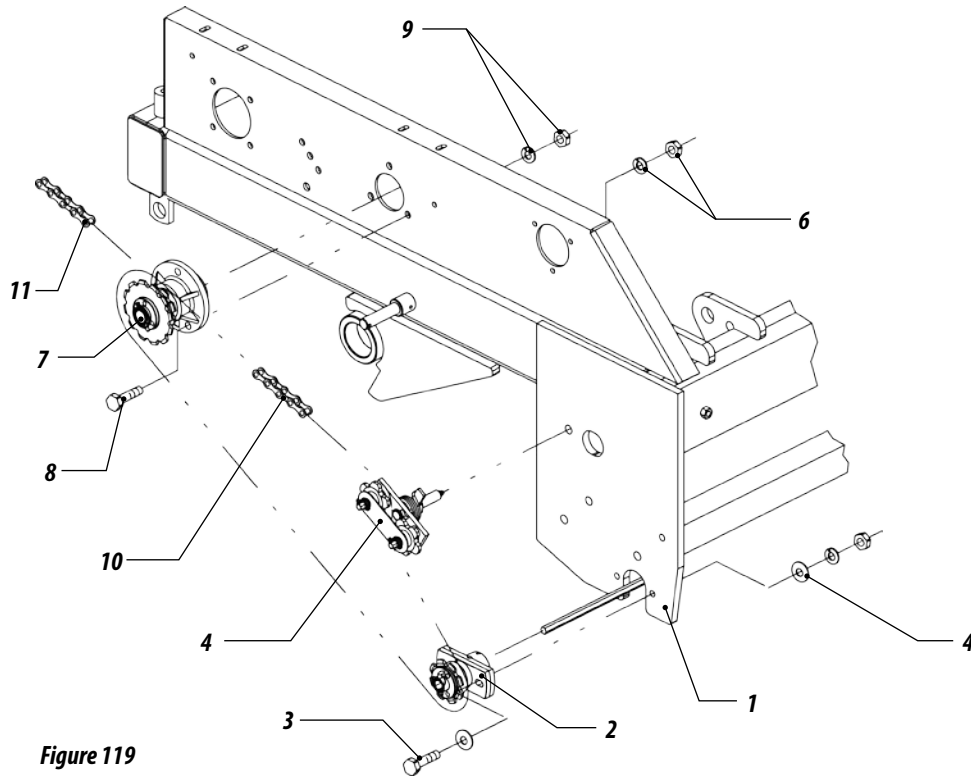

IMPORTANT

Put a limiter of 50 mm (16) on the side pistons to make up for the height of the CPD in relation to the normal rows.

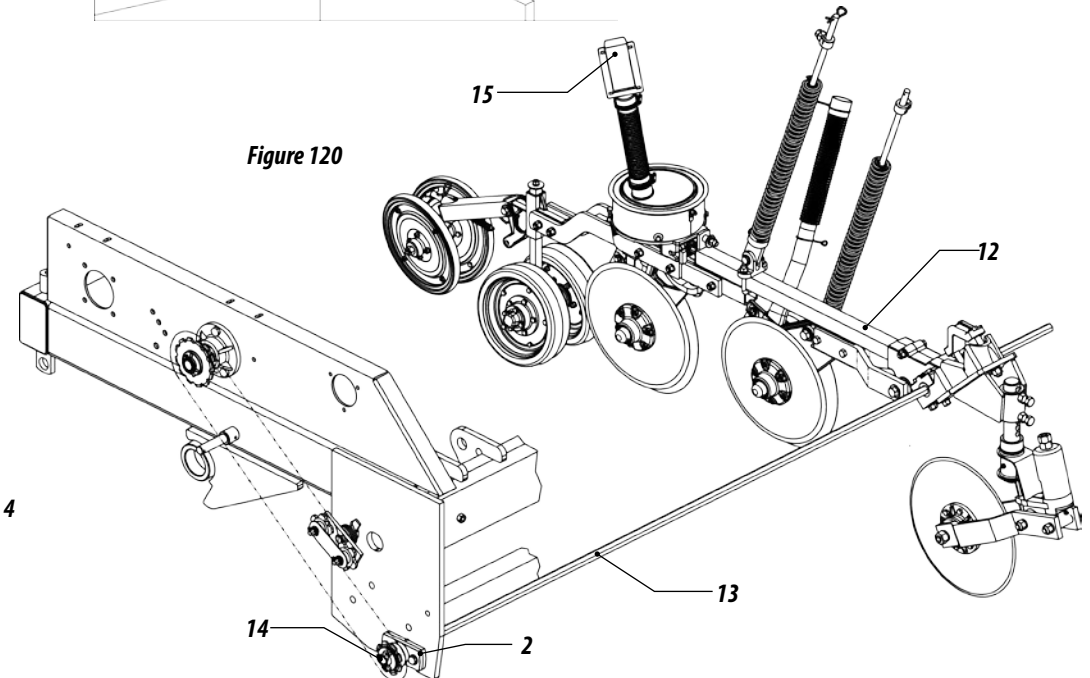

CPD KIT SEED ADJUSTMENT

SEED DISTRIBUTION DISCS

14- To change or replace the distribution discs, open the seed hopper, remove the wing nut (1), the upper support of the distribution disc (2) and the distribution disc (3) to be replaced.

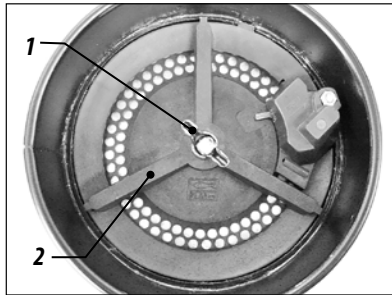
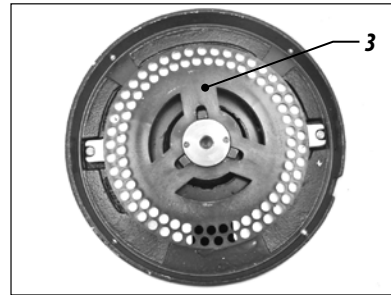

Figure 121



• Select the desired distribution disc and mount it in the seed hopper. Check the placement of the rings according to the seed distribution disc in the following manner:

- 15- For distribution disc of 3 mm, use one plastic ring of 5 mm and one metallic ring of 3.5 mm.
- 16- For distribution disc of 4.5 mm, use two metallic rings of 3.5 mm.
- 17- For distribution disc of 5.5 mm, use one plastic ring of 2.5 mm and one metallic ring of 3.5 mm.
- 18- For distribution disc of 8 mm, use one metallic ring of 3.5 mm.

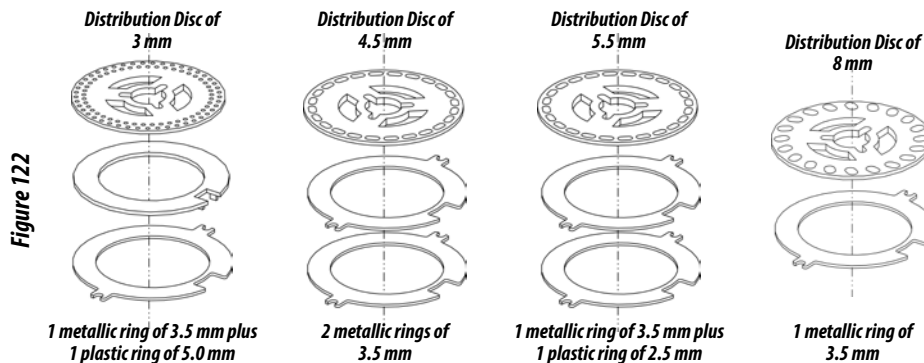

Figure 122

SEED DOSING STAR

- 19- The seed distributor leaves the factory mounted with the double dosing star trigger (1) in discs with double line of holes (2).
- 20- The single line discs (3) use one dosing star trigger (4).

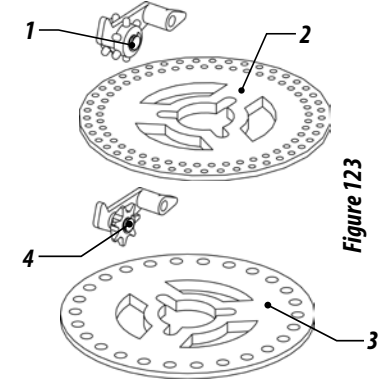

Figure 123

REPLACEMENT OF THE DOUBLE TRIGGER WITH THE SINGLE TRIGGER

- 21- The seed distributor leaves the factory mounted with the double dosing star trigger (1) for disc with double line of holes. To replace it with the one star trigger (2), remove the pin (3), the trigger (1), put the spring (4) in the insert, put the trigger (2) into the box (5) and lock with the latch (3).



Figure 124

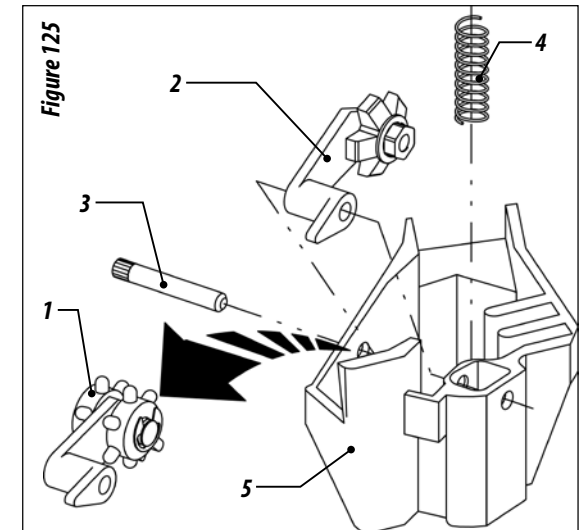

Figure 125

ADJUSTMENT OF THE CPD SEED DISTRIBUTION SYSTEM

CHANGE OF GEARS

22- Seed is distributed through the distribution discs, and to increase or reduce the quantity of seeds distributed per linear meter, change the motor gear "A" and driven gear "B", removing the latch (1).

23- After, change the gears and check the chain tension (2). The stretcher is equipped with torsion spring (3) for greater flexibility of the stretcher, and if greater pressure is required in the stretcher, loosen the internal nut (4) and turn the shaft (5) in the clockwise direction, then retighten the internal nut, figure 126.

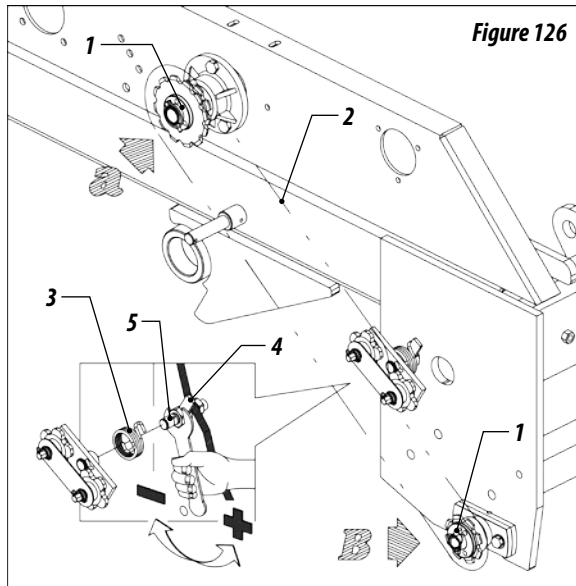

Figure 126

APPROXIMATE TABLE FOR SEED DISTRIBUTION

Seed Distribution for Different Types of Crops (Seed / Linear Meter)

Motor "A"	Driven "B"	Number of Distribution Disc Holes														
		17	18	19	20	24	26	30	38	40	48	50	62	64	72	90
8	17	1,7	1,9	2,0	2,1	2,5	2,7	3,1	3,9	4,1	4,9	5,1	6,4	6,6	7,4	9,3
8	15	2,0	2,1	2,2	2,3	2,8	3,0	3,5	4,4	4,7	5,6	5,8	7,2	7,5	8,4	10,5
8	16	2,3	2,4	2,6	2,7	3,2	3,5	4,0	5,1	5,4	6,5	6,7	8,3	8,6	9,7	12,1
8	12	2,5	2,6	2,8	2,9	3,5	3,8	4,4	5,5	5,8	7,0	7,3	9,0	9,3	10,5	13,1
8	11	2,7	2,9	3,0	3,2	3,8	4,1	4,8	6,0	6,4	7,6	7,9	9,9	10,2	11,4	14,3
8	10	3,0	3,1	3,3	3,5	4,2	4,5	5,2	6,6	7,0	8,4	8,7	10,8	11,2	12,6	15,7
8	9	3,3	3,5	3,7	3,9	4,7	5,1	5,8	7,4	7,8	9,3	9,7	12,0	12,4	14,0	17,5
8	8	3,7	3,9	4,2	4,4	5,2	5,7	6,6	8,3	8,7	10,5	10,9	13,7	14,0	15,7	19,7
9	8	4,2	4,4	4,7	4,9	5,9	6,4	7,4	9,3	9,8	11,8	12,3	15,8	15,7	17,7	22,1
10	8	4,6	4,9	5,2	5,5	6,6	7,1	8,2	10,4	10,9	13,1	13,7	16,9	17,5	19,7	24,6
11	8	5,1	5,4	5,7	6,0	7,2	7,8	9,0	11,4	12,0	14,4	15,0	18,6	19,2	21,6	27,1
12	8	5,6	5,9	6,2	6,6	7,9	8,5	9,8	12,5	13,1	15,7	16,4	20,3	21,0	23,6	29,5
13	8	6,0	6,4	6,7	7,1	8,5	9,2	10,7	13,5	14,2	17,1	17,8	22,0	22,7	25,6	32,0
15	8	7,0	7,4	7,8	8,2	9,8	10,7	12,3	15,6	16,4	19,7	20,5	25,4	26,2	29,5	36,9
17	8	7,9	8,4	8,8	9,3	11,1	12,1	13,9	17,7	18,6	22,3	23,2	28,8	29,7	33,4	41,8

Table 9

SEED DISTRIBUTION TABLES

24- Below are seed distribution tables with adjustment from the change of gears.

25- The values indicated in the tables are collected under normal working conditions and are subjected to variations like:

- **wheel skidding index;**
- **soil conditions;**
- **seed irregularity;**
- **operating speed.**

ⓘ IMPORTANT

The seed tables are based on the housing of one seed per hole. For example, if discs with an oblong hole are used for housing two seeds per hole, multiply the value obtained in the table for the corresponding disc by two. Always conduct the test to check the distribution.

SEED DISTRIBUTION DISCS FOR CPD KIT FOR EACH CROP

26 - The equipment leaves the factory with 7 different sets of discs (Standard Discs); separate optional discs or a combination of the 7 sets of discs according to the need of the customer can be purchased.

Table 10

Type of crop	Standard discs	
Soybean	90 Holes (8,5 x 9,0 mm)	x 4,5 mm
	40 Holes (8,0 x 15,0 mm)	x 8,0 mm
	40 Holes (7,5 x 15,0 mm)	x 8,0 mm
Corn* / Rice	26 Holes (13,5 mm)	x 4,5 mm
	26 Holes (13,0 mm)	x 4,5 mm
	26 Holes (11,0 mm)	x 4,5 mm
Beans	72 Holes (7,0 x 12,0 mm)	x 5,5 mm

*CORN CROP

27 - For the ideal choice of corn seed distribution disc, a sample of the seed should be collected from the batch to be planted and check if it is housed perfectly in the disc hole. The seed must pass through the hole without suffering friction or breakage (caused by the use of discs with small hole). In the case of large holes, two or more seeds may be housed per hole, causing double distribution, figure 127.

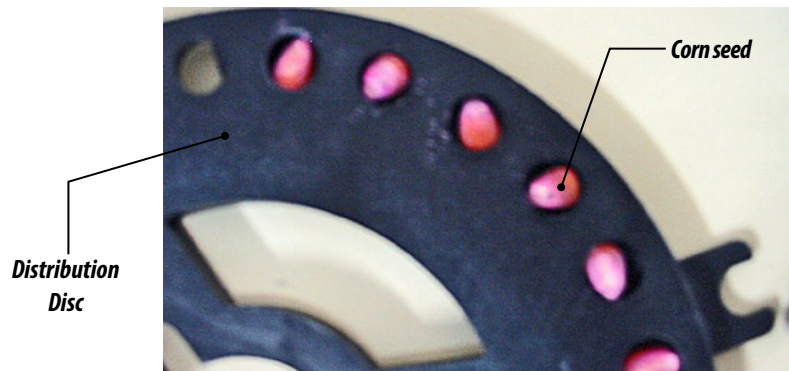

Figure 127

Type of crop	Optional discs	
Soybean	38 Holes (7,5 x 18,0 mm)	x 4,5 mm
	38 Holes (8,0 x 18,0 mm)	x 4,5 mm
	62 Holes (8,5 x 9,0 mm)	x 4,5 mm
Corn*	24 Holes (9,0 x 14,0 mm)	x 4,5 mm
	24 Holes (10,0 x 15,0 mm)	x 4,5 mm
	24 Holes (11,0 x 15,0 mm)	x 4,5 mm
	48 Holes (9/32")	x 4,5 mm
Sorghum	50 Holes (4,8 mm)	x 3,0 mm
	90 Holes (5 x 5,5 mm)	x 3,0 mm
Beans	64 Holes (8,0 x 12,0 mm)	x 5,5 mm
Peanut**	19 Holes (19,0 mm)	x 6,0 mm
Sunflower	20 Holes (7,0 x 16,0 mm)	x 4,5 mm
Non-linter cotton	30 Holes (5,5 x 11,0 mm)	x 4,5 mm
	40 Holes (7,5 x 12,5 mm)	x 4,5 mm
Others	17 Holes (9/32")	x 3,0 mm
	18 Holes (9/32")	x 3,0 mm
	30 Holes (8,5 x 12,0 mm)	x 4,5 mm
	30 Holes (9,0 x 13,5 mm)	x 4,5 mm
	30 Holes (10,0 x 14,5 mm)	x 4,5 mm
	30 Holes (11,0 x 15,5 mm)	x 4,5 mm
	40 Holes (8,0 x 13,5 mm)	x 4,5 mm
	90 Holes (5,0 x 5,5 mm)	x 3,0 mm
	90 Holes (7,0 x 7,5 mm)	x 4,5 mm
	Blind disc for special holes	

Table 11

**PEANUT CROP

28 - For peanut crop, the kit consisting of distribution disc with 19 holes of 3/4" x 6 mm (1) is used, internal flow adjustment (2), seed droppers (3), clamp (4), screw, washer and nut (5), wing nut and washer (6) and bifacial clutch disc (7), figure 128.

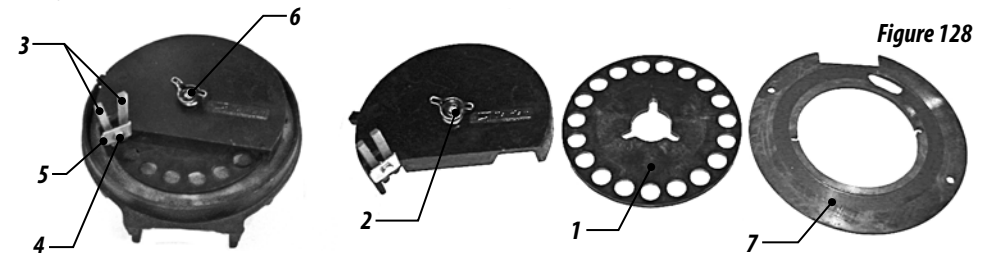

Figure 128



The distribution disc set plus rings should have a total thickness of 11.5 mm for perfect adjustment of the system. When the distribution disc has a thickness different from 4.5 mm or 8.0 mm, such as in the sorghum and bean crops, a special ring should be used as shown in page 32. (Thickness of standard rings: 3.5 mm each).

CPD SEED DEPTH CONTROL WHEEL ADJUSTMENT

ADJUSTMENT OF FIXED DEPTH WHEEL (ECCENTRIC SHAFT) AND V COMPACTION WHEEL

- 29- Seed depth control is adjusted individually through the convex compaction wheels (1), and through the screw (2).
- 30- The wheels are attached to a shaft with graded ends (3), specially designed to enable compaction, depth control and to bury the seed. To obtain these adjustments on the wheel, loosen the nut (4) and turn the shaft (3), observing the movements of the wheel.
- 31- **Inclined parallel:** To compact the soil without accumulating soil over the seed. (dry lands)
- 32- **Inclined open:** When the land is very wet and there is no soil over the seed.
- 33- **Inclined closed:** To remove soil, preventing more soil from falling over the seed. (Dry and wet lands)

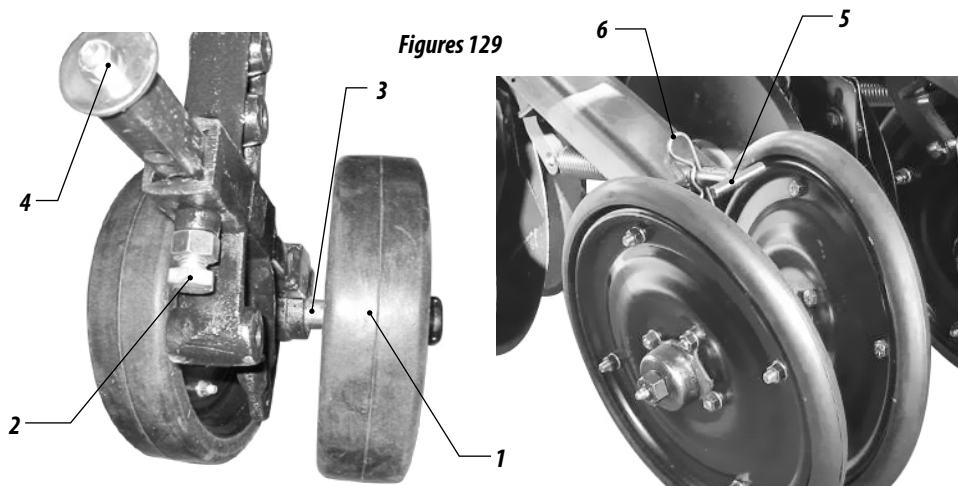

Figures 129

- 34- The "V" compaction wheels are adjusted through the pin (5). For greater pressure, pull the pin out and lock with the retaining pin (6).

ADJUSTMENT OF OSCILLATING DEPTH LIMITING WHEEL (OPTIONAL)

- 35- The depth of the seed is performed individually by the depth limiting wheels. To adjust, pull the lock pin (1) and the manipulator (2). Move the wheel (3) up to the hole of the desired depth.
- 36- After, replace the manipulator and the lock pin.
- 37- The oscillating depth limiting wheels have only one point of support that enables their oscillation, and in the case of any obstacle in their path or soil irregularities, it will raise it to transpose it, immediately returning to the initial position without raising the double disc from its position, figure 130.

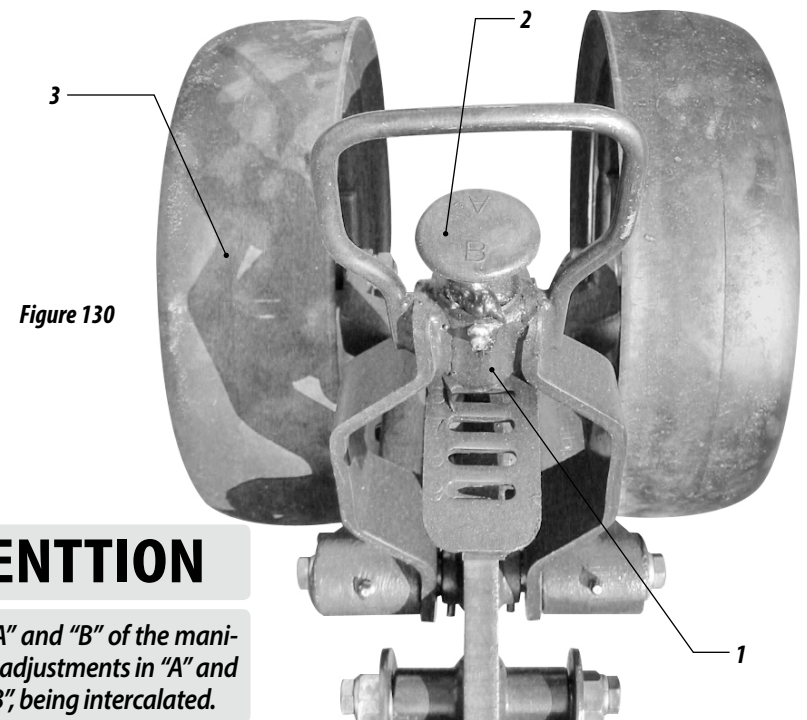

Figure 130



ATTENTION

The adjustments "A" and "B" of the manipulator (2) offers 9 adjustments in "A" and 9 adjustments in "B", being intercalated.

ADJUSTMENT OF "V" COMPACTION WHEELS

- 38- The "V" wheels are used to press the side of the furrow causing the soil to be immediately placed over the seed, avoiding excess compaction, and facilitating plant germination and plant development.
- 39- The pressure of the wheel (1) is performed through the handle (2) that is displaced backwards to apply more pressure on the wheels.
- 40- The wheels can be inclined through the handle (3). For this adjustment, loosen the screw (4) and move the handle observing the position of the wheel and its use:

- **Position "A" (closed), put at least soil over the seed.**
- **Position "B" (open), put more soil over the seed.**

Figure 131

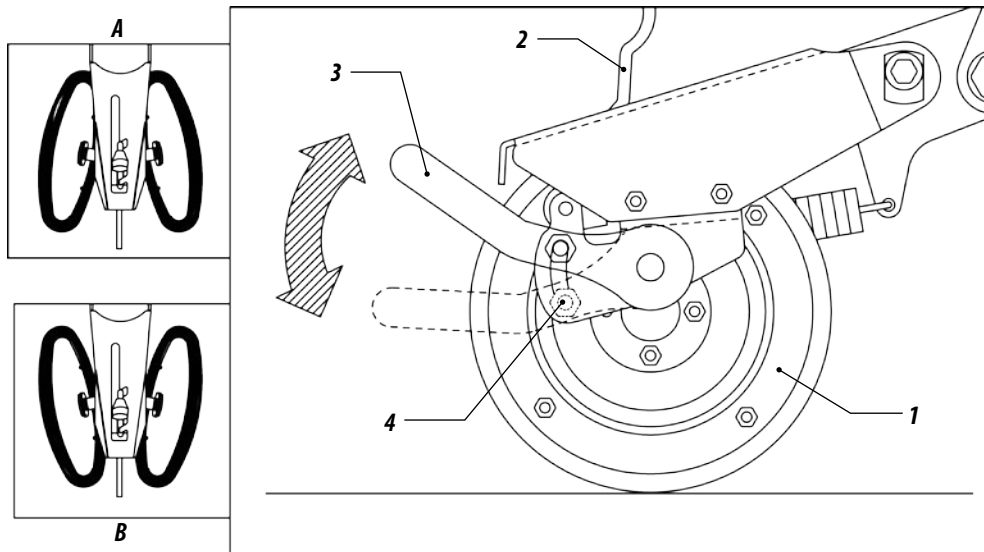

IMPORTANT

Perform the same adjustment on all the compaction wheels and considering the type of soil, seed and planting depth in order to not affect the free emergency of the plants.

- 41- For horizontal displacement of the wheels, they must be developed with eccentric bushings (1). For this adjustment, loosen the screws (2), turn the said bushings (1), with a switch to actuate and align the wheels with groove, positioning greater or smaller amount of soil beside the seed.
- 42- This adjustment must be performed according to the type of soil and crop.

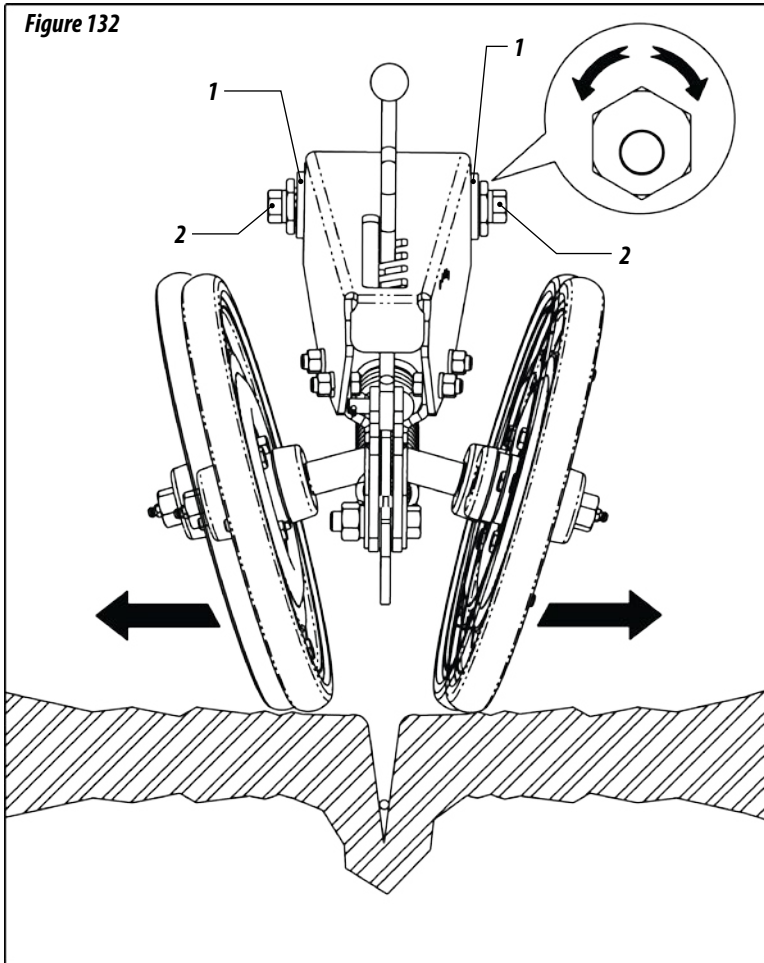

ADJUSTMENT OF THE DOUBLE DISC CLEANERS

43 - The double discs have cleaners (1) that are flexible and adjustable through the screw (2), to remove the soil that sticks to the discs, figure 133.

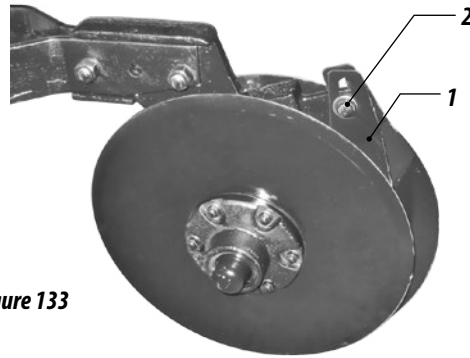

Figure 133

POSITION OF THE FURROWER

44 - The furrower has two working positions. For this adjustment, remove the pin (1), move the furrower (2) to the hole of the desired position and replace the pin (1), figures 134.

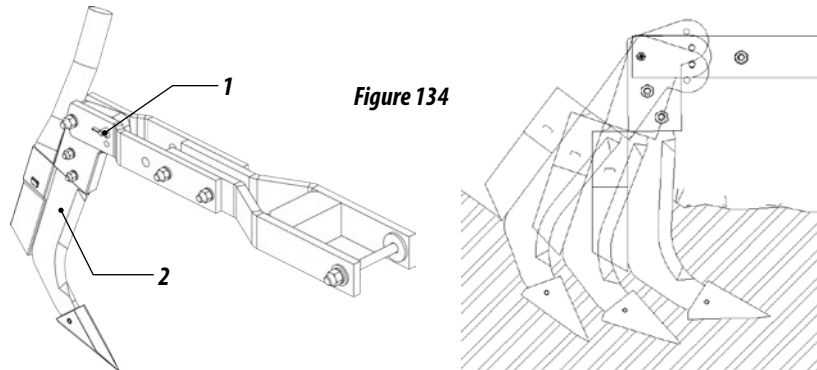

Figure 134

NOTE

The pin (1) works as a fuse made of silver steel with controlled hardness.

OPENING OF THE FURROW AND POSITION OF THE FERTILIZER IN THE SOIL

- The furrow opening in the soil to store the fertilizer is performed by the double discs or furrowers in the following systems:

- 45 - *Side and below the seed fertilization (for double discs);*
- 46 - *Fertilization in the same row and below the seed.*

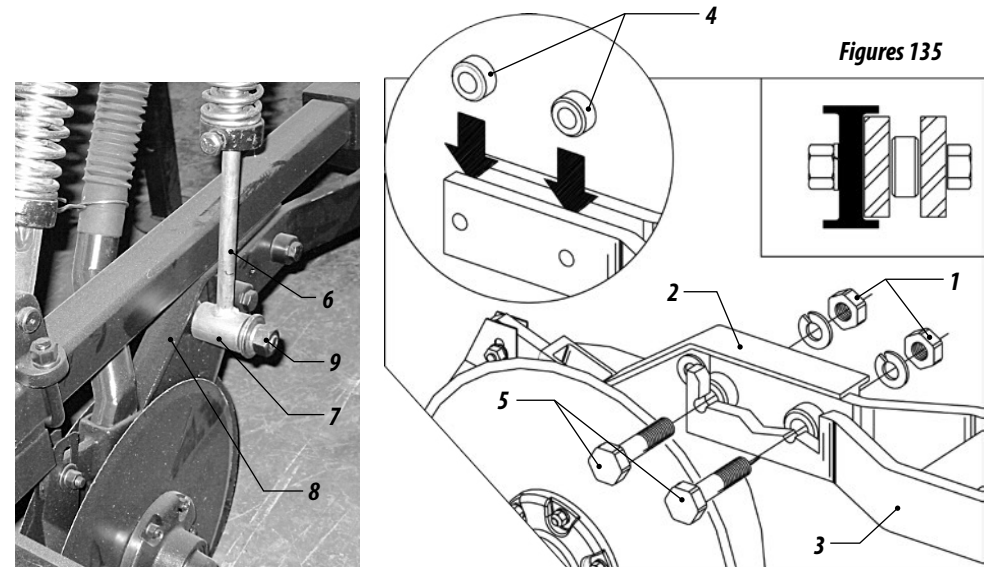

- The planting rows leave the factory regulated in order to fertilize in the same row and below the seed. For side and below the seed fertilization, proceed as follows:

- 47 - Remove the spring rod (6), loosen the nuts (1), remove the casing (2) that is between the fork plates (3), transfer it to one of the sides of the fork, fixing it with screws (5) washers and nuts (1), as shown in FIGURES 115, then replace the spring rod (6), inserting the bigger bushings (7) and smaller bushings (8) on the same side the casing was removed, fixing with pin and nut (9), figures 135.

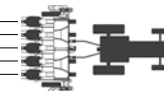

TIRE PRESSURE

- 01 - The tires must always be correctly calibrated to avoid premature wears by excess of lack of pressure and ensuring precision in the distribution.
- 02 - Calibration of the seed drill tires must be 18 lb / inch² with water and 22 lb / inch² without water for each one.

Figure 136

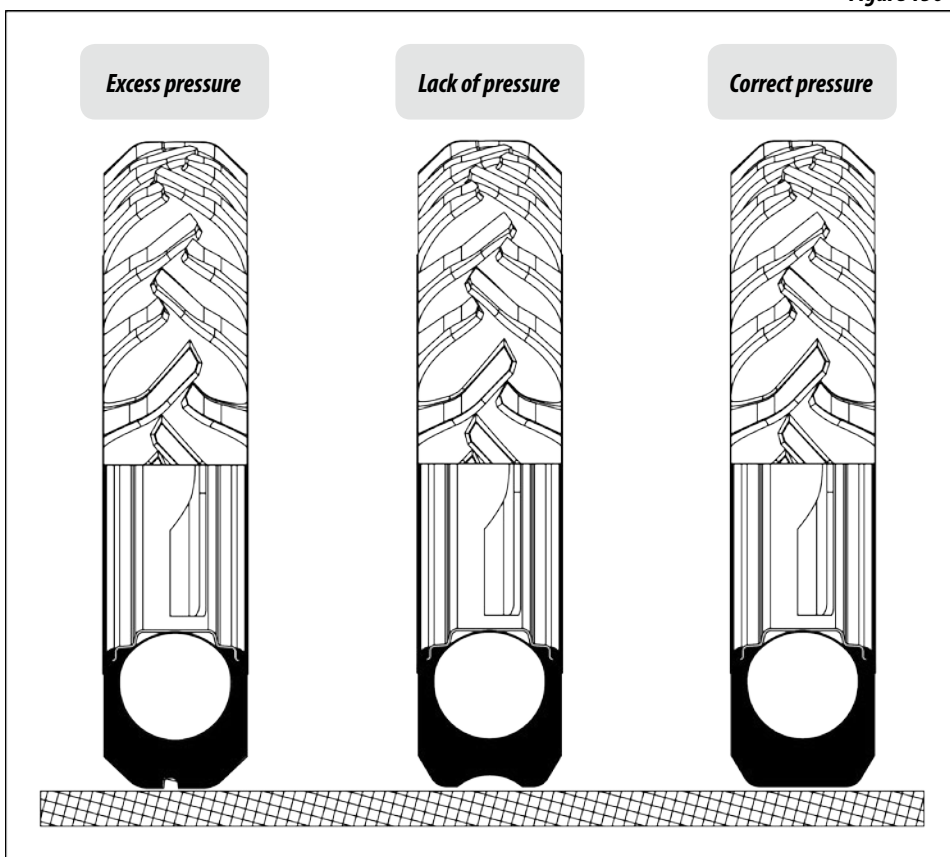

LUBRICATION

- 03 - Lubrication is indispensable for a good performance and higher durability of the moving parts of the seed drill, which helps economize maintenance costs.
- 04 - Before executing the operation, carefully lubricate all greasers, always observing the lubrication intervals in the pages below.
- 05 - Check the quality of the lubricant in relation to its efficiency and purity, avoiding the use of products contaminated with water, soil and other agents. (OBSERVE TABLE BELOW)

TABLE OF GREASE AND EQUIVALENT PRODUCTS

MANUFACTURER	TYPE OF GREASE RECOMMENDED
Petrobrás	Lubrax GMA 2
Atlantic	Litholine MP 2
Ipiranga	Super Graxa Ipiranga Ipiranga Super Graxa 2 Ipiflex 2
Castrol	LM 2
Mobil	Mobilgrease MP 77
Texaco	Marfak 2 Agrotex 2
Shell	Retinax A Alvania EP 2
Esso	Multipurpose grease H Litholine MP 2
Bardahl	Maxlub APG 2 EP

Table 12



*In the case of other lubricants and/or equivalent grease brands that are not contained in this table, consult the technical manual of the manufacturer.

TABLE OF OIL AND EQUIVALENT PRODUCTS

MANUFACTURER	TYPE OF OIL RECOMMENDED
Atlantic	Pennat EP 150
Esso	Spartan EP 150
Ipiranga	Ipiranga SP 150
Petrobrás	Incl. EGF 150 PS
Shell	Retinax A Alvania EP 2
Texaco	Meropa 150

Table 13



In the case of other lubricants and/or equivalent grease brands that are not contained in this table, consult the technical manual of the manufacturer.

LUBRICATE EVERY 10 WORKING HOURS

Figures 137

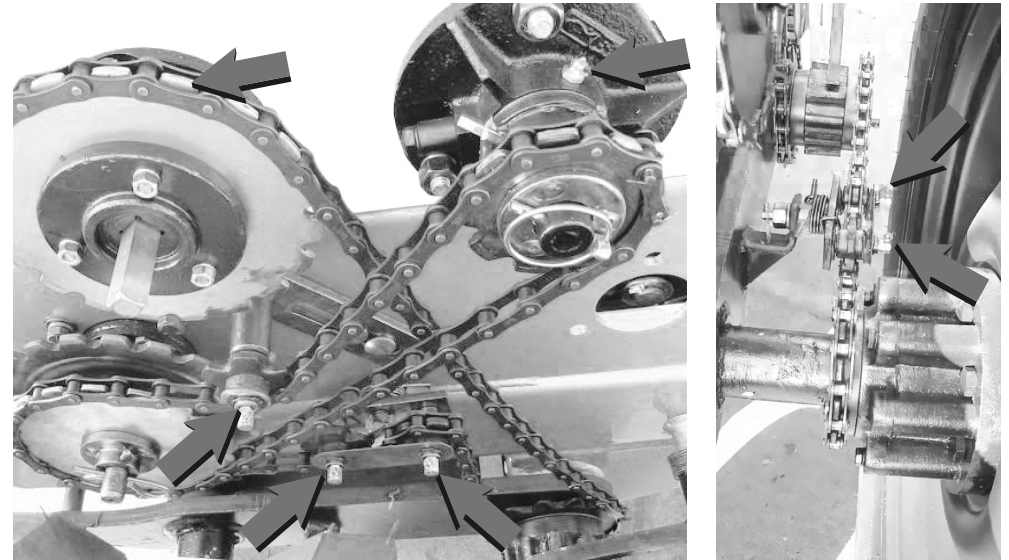
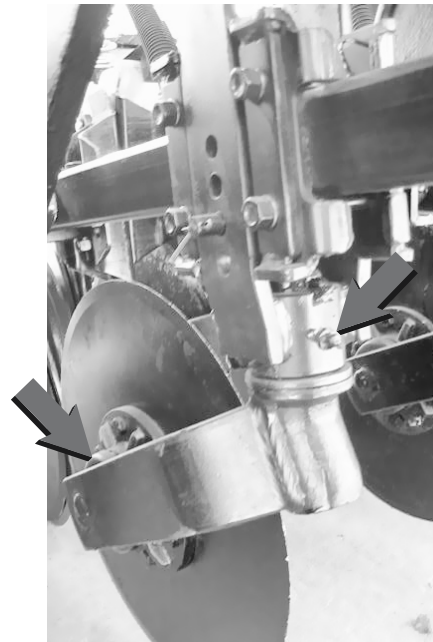

LUBRICATE EVERY 30 WORKING HOURS
Figures 138



LUBRICATE EVERY 60 WORKING HOURS
Figures 139

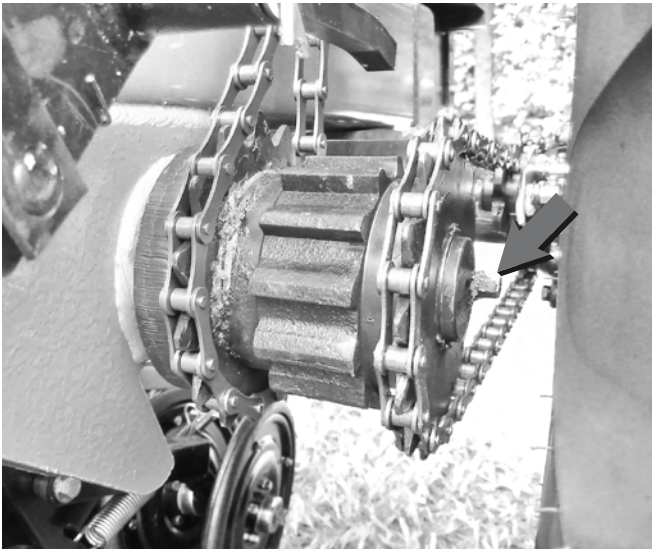

LUBRICATE EVERY 200 WORKING HOURS
Figure 140

- Lubricate periodically the double disc housing and the gauge wheels more specifically at every 200 working hours. Repeat this procedure when you finish the season following the instructions below:
- 01 - Remove the ring (#1) from the housing (#2), inspect the bearing adjusting by the castle nut (#3), insert grease on the dust cap (#4) install the it again on the housing with the ring (#1). figure 140.

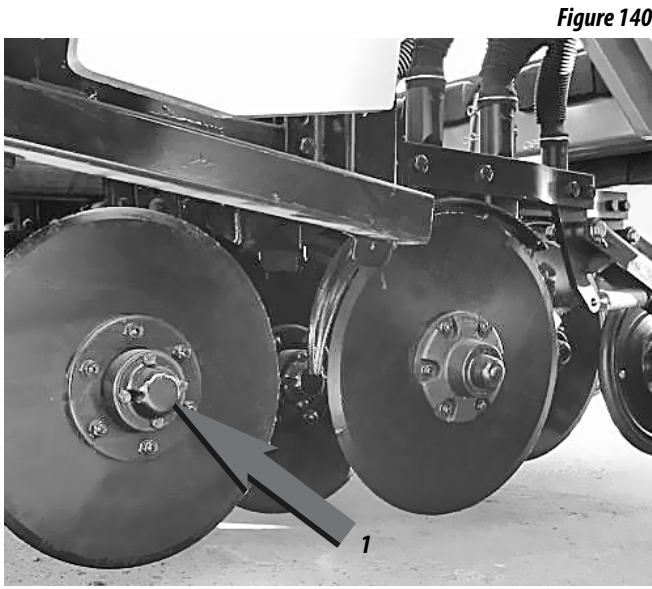

⚠ IMPORTANT

Do not use excess grease in the ratchet, respect the interval of 60 hours to re-lubricate

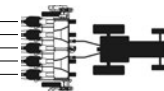

TROUBLESHOOTING	PROBABLE CAUSES	SOLUTIONS
<i>During planting, fertilizer starts to leak from the safety outlets.</i>	<i>Blocked hoses or pieces of plastics in the spiral fertilizer conductors.</i>	<i>Unblock the hoses or remove the upper channel that gives access to the spiral, turn the shaft anti-clockwise until the foreign body is unthreaded.</i>
<i>Fertilizer hub shaft does not turn.</i>	<i>Spiral blocked with wet fertilizer or excess fertilizer in the closed row.</i>	<i>Unblock the spirals, check for loose chute and if the fertilizer is entering through the sides of the chute.</i>
<i>Cannot insert the quick coupling system of the hoses to the tractor.</i>	<i>The hoses were disconnected with pressure or are supporting the weight of the seed drill in the hydraulic.</i>	<i>Drain the hoses or put the seed drill on the support and finally release the pressure.</i>
<i>One planting row is not as deep as the other.</i>	<i>Different pressure adjustments in the depth control wheels or in the springs of the row.</i>	<i>Adjust all the depth wheels the same and the pressure of the row unit springs.</i>
<i>The furrow opens up too much during planting.</i>	<i>Sticky soil and sticks to the discs or excess working speed.</i>	<i>Reduce working speed.</i>
<i>The pistons stopped working, raising the seed drill and then not lowering afterwards or vice-versa.</i>	<i>Different quick coupling, ball type male and needle type female or vice-versa.</i>	<i>Change the quick coupling, using two of the same type.</i>
<i>Strange noise when operating or moving with the seed drill loaded.</i>	<i>Loose wheels or wheel hub with set.</i>	<i>Retighten the wheel nuts. Adjust the wheel hub rollers.</i>
<i>The seed drill moves out of the planting row from one side to the other, in width.</i>	<i>Traction bar of the tractor is loose.</i>	<i>Use the pin that accompanies the seed drill. Fix the traction bar of the tractor in the center orifice.</i>
<i>The wheel ratchet disconnects or is not completely coupled.</i>	<i>The spring gave way or lost the action due to accumulation of grease or dust.</i>	<i>Dismount the ratchet and wash the springs with diesel oil and lubricate it with small amount of grease, as specified in the lubrication chapter in the manual.</i>
<i>Land is highly compacted and increases the pressure of the discs and they do not operate in the desired depth.</i>	<i>No ballast in the seed drill.</i>	<i>Put the ballasts, add water to the tires and lock the wheel jointing system.</i>
<i>The grooved discs touch the soil during transport.</i>	<i>Bushing of the triple spring rod is loose or grooved disc is adjusted in the upper orifices.</i>	<i>Fix the sprig rod bushings and put the support of the grooved disc in the lower orifices in order for them to be much higher.</i>

Table 14

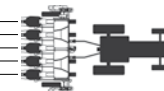

PLANTING ROW WITH DEPTH WHEEL AND COVER

Figure 141

• Planting rows consisting of:

- 01 - Grooved, smooth or corrugated cutting disc (1);
- 02 - Double non-central discs for seeds with individual cleaners (2);
- 03 - Depth control wheel with angular adjustments (3);
- 04 - Smooth compaction wheel with depth adjustment (4);
- 05 - Conical iron compaction wheel (5).

ROW WITH GROOVED CUTTING DISC WITH "V" COMPACTION WHEEL

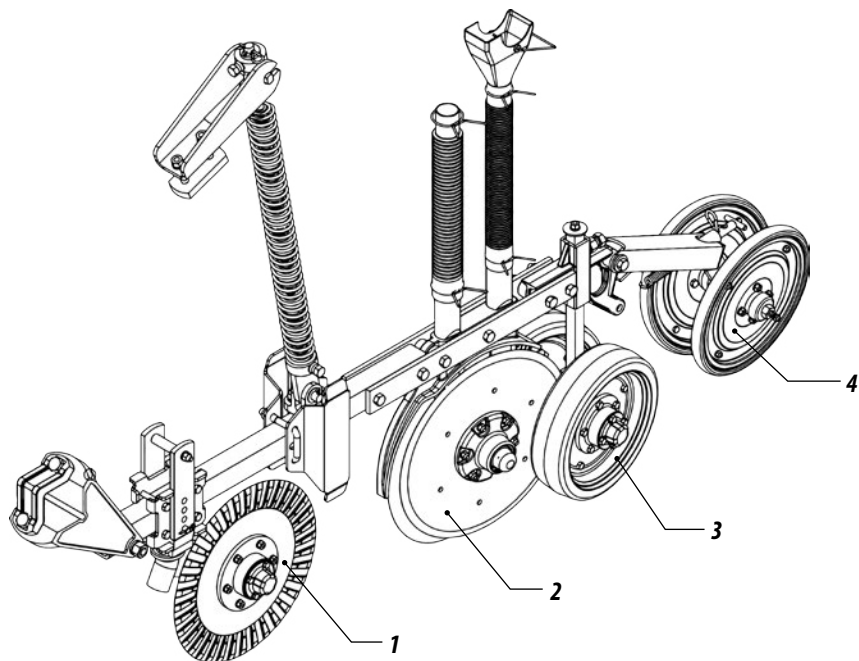

ROW WITH GROOVED CUTTING DISC WITH IRON COMPACTION WHEEL

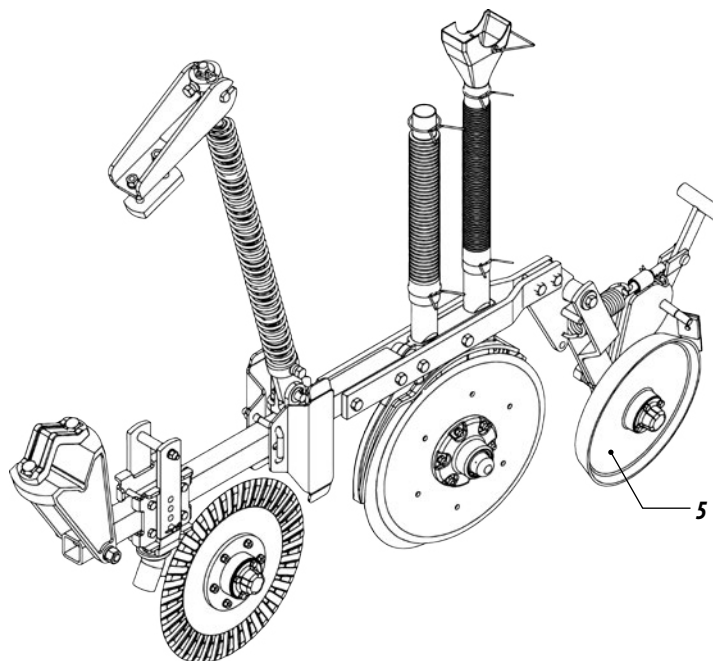

DEPTH WHEEL WITH CONCAVE, CONVEX AND SMOOTH ADJUSTMENT SUPPORT

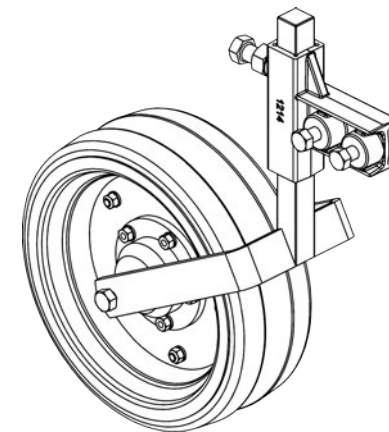

CONCAVE, CONVEX AND SMOOTH COMPACTION WHEEL

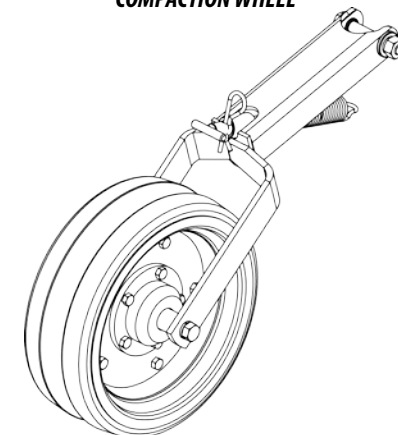

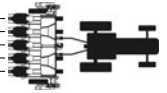

- Mixer set consisting of:
- 01 - Complete mixer shaft (1);
- 02 - Support of the complete mixer shaft (2);
- 03 - Complete transmission system (3);
- 04 - Hectare counter (4).

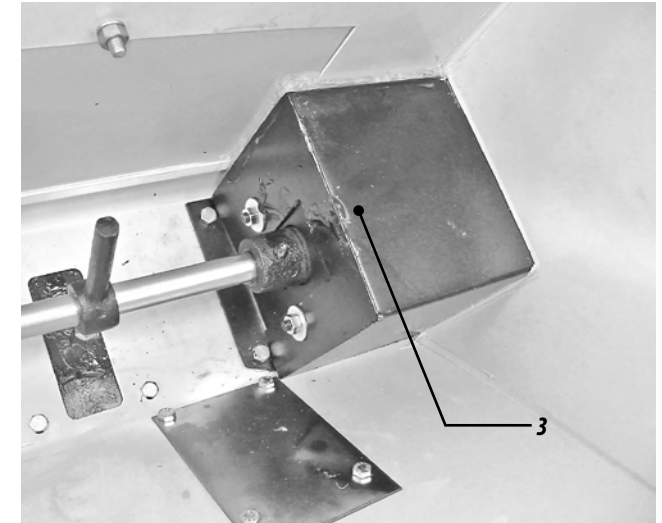
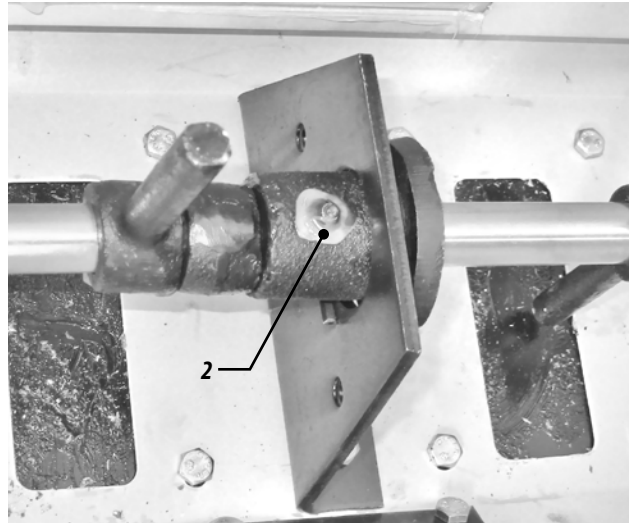
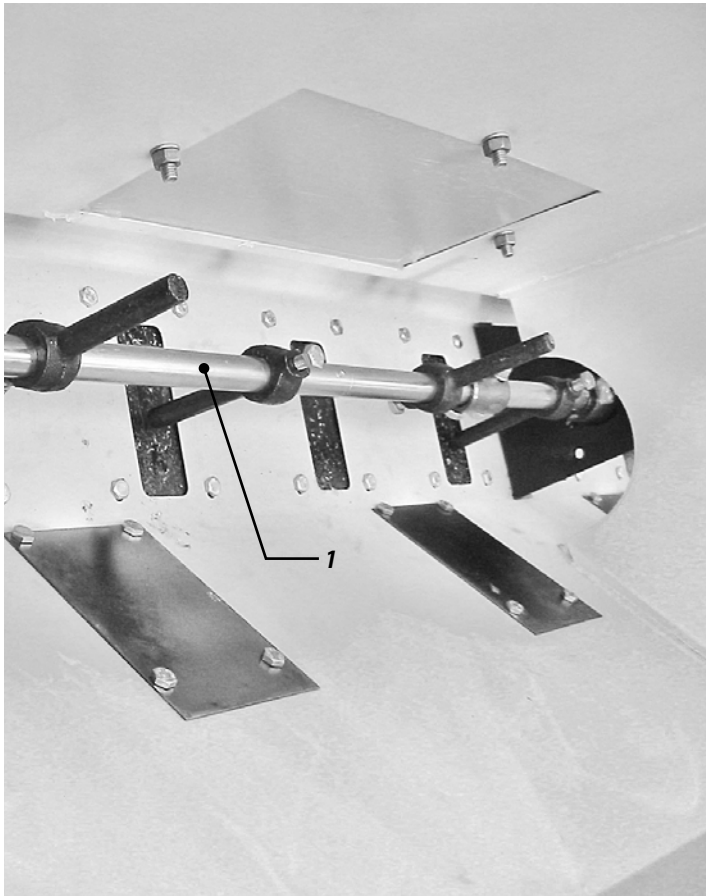

Figures 142

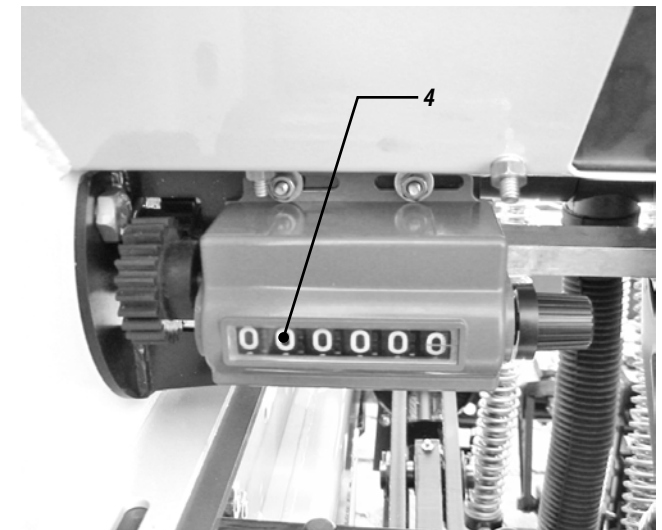
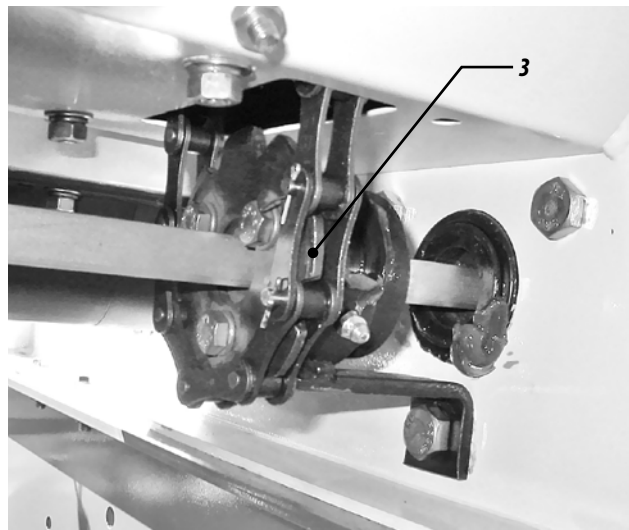

HECTARE COUNTER - LOCATION AND MOUNTING

Figures 143

The hectare counter (1) will be mounted on top of the seed on the right side of the SPD as follows:

- 01 - Remove all the retaining pins (2) that fixes the seed rotors (3) then displace the square shaft (4). Remove the lower screw of the hub (5) and attach the support (6) of the hectare counter (1) with the screw (7), figure 143.

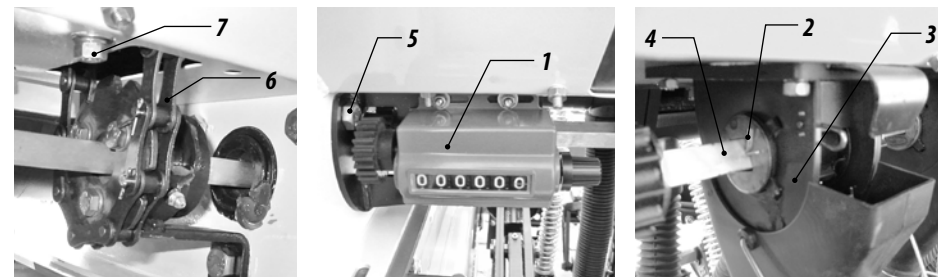

HOW TO CALCULATE THE PLANTED AREA

- To know how many hectares were planted, proceed as follows:
- 02 - After planting, check the hectare counter.
- 03 - Check the useful planting width (multiplying the number of rows by the space between them).
- 04 - Use the formula in the example below.
- E.g. The hectare counter reads 10,200 and the planting width is 4.08 meters, the conversion factor is 5.556 meters, calculate:**

A = Planted area [Ha]
E = Useful width of the equipment (m)
L = Hectare counter reading
FC = Conversion factor

$$A = (E \times L \times fc) / 10.000 \Rightarrow A = (E \times L \times 5,556) / 10.000 \quad [Ha]$$

Formula: $A = \frac{L \times F \times E}{H}$

Resolves: $A = \frac{10,200 \times 5,556 \times 4,08}{10.000}$

$A = 23,12 \text{ Ha}$

⚠ ATENTION

Zero the hectare counter at the beginning of planting.

Information:

- A = Planted Area**
- E = Useful Planting Width**
(E.G. 4.08m this measurement corresponds to an spd with 24 rows with 170 mm spacing)
- F = Conversion Factor (5.556)**
- L = Hectare Counter Reading (e.g. 10,200)**
- H = hectare (ha 10.000)**

CONVERSION FACTOR – SPD HECTARE COUNTER

Input Data		Output Data	
ø Tire [mm]	1210	Total Reduction	1,4615
Z 1 Wheel	13	1 unid//Hectare=>[m]	5,556
Z 2 Ratchet	14	Conversion Factor (fc)	5,556
Z 3 Ratchet	14		
Z 4 Seed Shaft Inlet	19		
Z 5 Seed Shaft Outlet	20		
Z 6 Hectare Counter Inlet	20		

Table 15

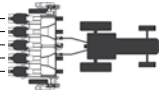

FERTILIZER SYSTEM

• After planting, do not leave fertilizer in the hoppers by cleaning them as follows:

- 01 - Remove the protection cover of the transmission (1), loosen the nuts and washers (2) of the hub (3) only from the outer part of the seed drill, pull the hub with the complete shaft (3), turning it to facilitate removal. Check the PVC channels (4) located at the bottom of the hopper and change in the case of wear.
- 02 - Clean the hoppers and also the shafts and then wash them with running water. Remount the shafts observing the correct mounting of the channel assembly because the fertilizer outlet orifices of both the channel and the spout must coincide as shown in the figure 144.

SEED SYSTEM

• At the end of the each working day, it is recommended to remove all the seeds from the distribution box and clean it. To clean the seed hopper, proceed as follows:

- 03 - Remove the seed spouts (5);
- 04 - Completely open the cover (6) of the seed distribution box;
- 05 - Unlock the counter handle (7) leaving it loose;
- 06 - Completely open the seed handle (8) to number 18 of the scale;
- 07 - Turn the seed shaft (9) with the key until all the seed falls out;
- 08 - Clean the seed hopper;
- 09 - Remount the hopper after cleaning, figure 144.

IMPORTANT

If the seed drill is to be stored, also remove the fertilizer and seed conductor sleeves, wash them with water and neutral soap and put them back.

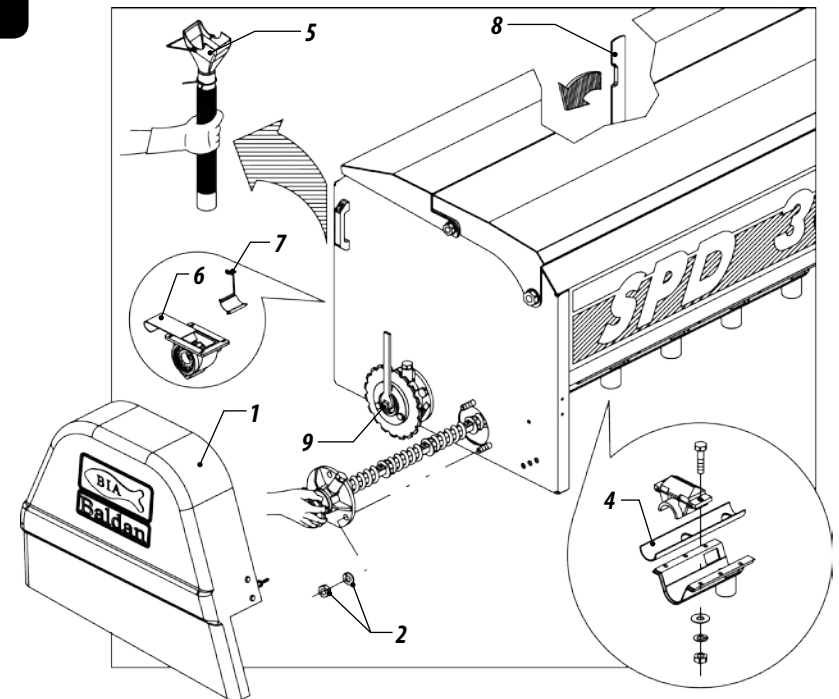

Figure 144

CPD SEED SYSTEM CLEANING

10- At the end of each working day, it is recommended to empty the seed hoppers of the CPD, remove the distribution discs (1) and clean them. Observe the operation of the seed doser (2), checking the pressure of the spring of the triggers, thus ensuring the maximum precision in the seed distribution, figure 145.

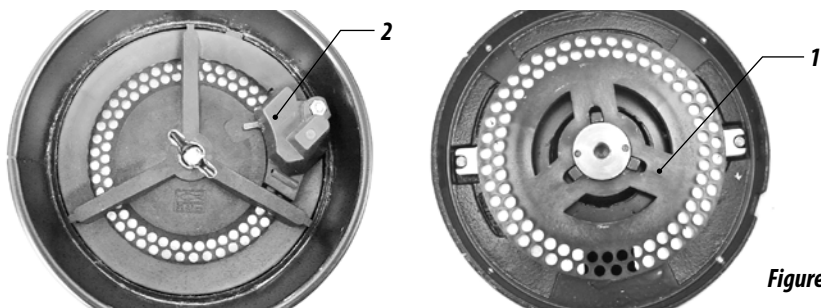

Figure 145



It is necessary to clean the system twice daily when using products for seed treatment (inoculants, insecticides, graphite, etc.).

GENERAL CLEANING

- 11- When storing the seed drill, proceed with a general cleaning, washing it with neutral soap. Check if the paint is not worn, otherwise, apply a coat to the affected parts, rub protector oil and completely lubricate the seed drill.
- 12- Apply the transmission chains and keep them in oil until the next plantation.
- 13- Completely lubricate the seed drill.
- 14- Check all the moving parts of the seed drill for wear or looseness and perform the necessary adjustments or replacement of the parts, leaving the equipment ready for the next plantation. Only use original BALDAN parts.
- 15- After all the maintenance services, keep your seed drill in a covered and dry place, duly supported. Prevent the discs from being in direct contact with the soil.
- 16- We recommend washing the equipment at every new planting.

21

OPERATIONS

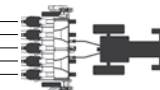

1	<i>After the first day of work with the seed drill, retighten all screws and nuts. Check the conditions of the pins and latches.</i>
2	<i>Always kept the tires with the same calibration of 18 lb / inch² with water and 22 lb / inch² with water in each one, to avoid wear and keep the uniformity of the planting.</i>
3	<i>Observe the lubrication intervals.</i>
4	<i>When supplying the hoppers, check inside for objects such as screws, nuts, etc. Always use uncontaminated seeds and fertilizer.</i>
5	<i>Always observe the functioning of the seed and fertilizer distribution mechanisms and also the adjustments established at the beginning of planting.</i>
6	<i>Always keep the seed drill leveled, the traction bar of the tractor always fixed and the working speed must remain constant.</i>
7	<i>Always check the depth of the seed and fertilizer as well as the pressure in the compaction wheels.</i>
8	<i>Observe the position of the fertilizer in relation to the seed in the soil.</i>
9	<i>The row markers must be adjusted according to the spacing of the crop to be planted.</i>

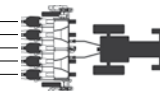

PRODUCT IDENTIFICATION

01 - To view the parts catalog or to request technical assistance from BALDAN, always indicate the model (1), serial number (2) and date of manufacture (3), which is on the identification label (4) of the sower.

- Identify the information below in order to always have the correct information on the life of your seed drill.

Owner's name: _____

Dealer: _____

Farm: _____

City: _____ *State:* _____

Warranty certificate Nr.: _____

Model: _____

Serial number: _____

Date of purchase: _____ *Invoice Nr.:* _____

ALWAYS ORIGINAL PARTS REQUIRED BALDAN



Marketing Baldan

*Edition of Catalogs
and Manuals*

Code: 6055010187-7
Revision: 01
CPT: SPD14417



The drawings in this instruction manual are of illustrative purposes only.



In case of doubt do not operate the equipment, please contact our after-sales service.
Telephone: 0800-152577
e-mail: posvenda@baldan.com.br



BALDAN IMPLEMENTOS AGRÍCOLAS S/A.

Av. Baldan, 1500 | Nova Matão | CEP: 15993-000 | Matão-SP | Brasil

Phone: (0**16) 3221-6500 | Fax: (0**16) 3382-6500

Home Page: www.baldan.com.br | e-mail: sac@baldan.com.br

Export: Phone: 55 16 3221-6500 | Fax: 55 16 3382-4212 | 3382-2480

e-mail: export@baldan.com.br



60550101877