

CRSG/CRI/CRI-R

- **Wheel Type OffSet Disc Harrow**
- **Drag Type OffSet Disc Harrow Remote Control**
- **Drag Type OffSet Disc Harrow Remote Control - Strong**

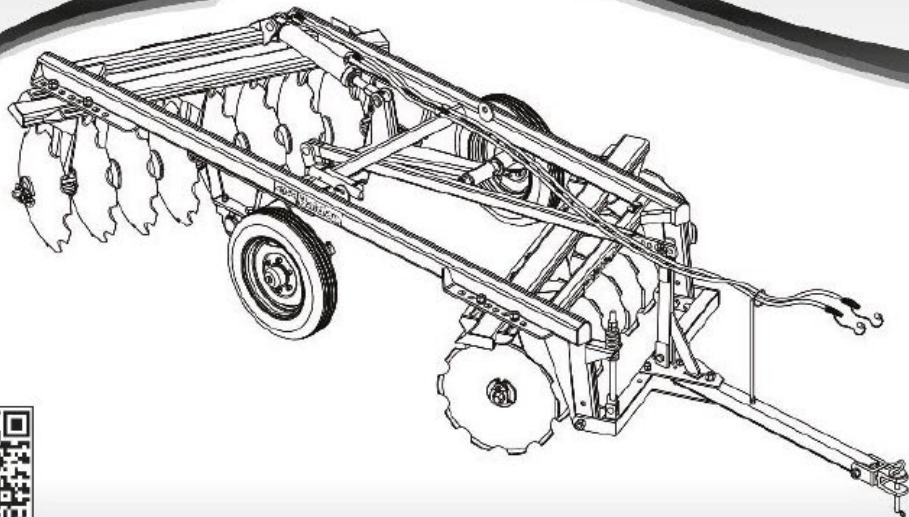

www.baldan.com.br

INTRODUCTION

We thank you for the preference and congratulate your excellent choice in acquiring an implement of outstanding quality, manufactured in accordance with the advanced technology of **BALDAN IMPLEMENTOS AGRÍCOLAS S/A.**

This manual will assist you, in proceeds necessities, since when you bought until the operational proceeds application, security and maintenance.

The **BALDAN** guarantees that deliver this implement to the dealer, working properly, and in perfect conditions.

The dealers it's under the responsibility to keep the protection and conservation while keep the implement in your stock, and than, to assembly, tighten, lubrication and overhaul.

On time of the technical deliver, the dealer must to have conducted the user customer about the maintenance, safety, and your obligations in a possible technical assistance, the obligation to see the warranty terms and read the instruction manual. Any solicitation of warranty, please contact our Baldan technical service, by your Baldan dealer that you bought our implement.

Reaffirm the necessity to read carefully of warranty certificate and note all of items from this manual, therefore you will increase the working life of your equipment.



Instruction Manual



INDEX

01. Safety rules.....	4 - 8
02. Components	9
03. Technical specifications - CRSG	10
04. Technical specifications - CRI	11
05. Technical specifications - CRI-R	12
06. Assembly	13 - 15
<i>Assemble of front and rear gang</i>	<i>16 - 17</i>
<i>Mounting of the hydraulic system and articulating wheel assembly CRI/CRSG 12 - 28 models with single wheels.....</i>	<i>18</i>
<i>Mounting of the hydraulic system and the articulating wheel assembly CRI/CRSG 32 - 48 models with dual wheels.....</i>	<i>19</i>
<i>CRSG/CRSG 32 - 48 models with large single wheel version.....</i>	<i>20</i>
<i>Mounting of the hitch system.....</i>	<i>21-22</i>
07. Hitching to the tractor.....	22
08. Adjustments and operations.....	23
<i>Transport</i>	<i>23</i>
<i>Transport / Work.....</i>	<i>23</i>
<i>Disk Harrow Gangs Adjustments.....</i>	<i>24</i>
<i>Displacement Adjustment</i>	<i>24</i>
<i>Hitch Transversal Bar Adjustment</i>	<i>25</i>
<i>Operations</i>	<i>26</i>
09. Lubrication	27
10. Lubrication Points	28 - 29
11. Bearing adjustments	30
12. Cleaning.....	30
13. Hourly production of the CRSG/CRI/CRI-R.....	31 - 33
14. Identification	34 - 35

01. SAFETY RULES



THIS ALERT SYMBOL INDICATES IMPORTANT SAFETY NOTES. WHENEVER YOU FIND IT IN THIS MANUAL, READ THE MESSAGE WITH ATTENTION TO AVOID ANY ACCIDENT.

WARNING

- *Read this instruction manual carefully to know the recommended safety rules.*



WARNING

- *Only start the tractor operations, when are you properly accommodated and with the seat belt fasted.*



WARNING

- *Never carry people over the tractor or equipment.*



WARNING

- *Há riscos de lesões graves por tombamento ao trabalhar em terrenos inclinados.*
- *Não utilize velocidade excessiva.*



01. SAFETY RULES

WARNING

- Before any equipment maintenance, make sure that is properly stopped.
- Avoid getting hit.



WARNING

- Do not work with the tractor if the front be without enough weight to the rear equipment.
- There is tendency to lift, add weights at front or front wheels.



WARNING

- Never weld the wheel mounted with tire, the heat may cause air pressure increase and provoke the explosion of the tire
- When lling the tire, position yourself besides the tire, never in front of it.

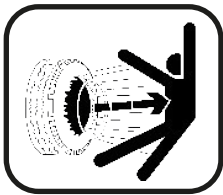

WARNING

- Before beginning the work or transportation of CRSG/CRI/CRI-R, check if there are people or blockages close to it.



FOLLOW ALL RECOMMENDATIONS, WARNINGS AND SAFE PRACTICES RECOMMENDED IN THIS MANUAL, UNDERSTAND THE IMPORTANCE OF YOUR SAFETY. ACCIDENTS MAY LEAD TO DISABILITY OR INCLUDING DEATH. REMEMBER, ACCIDENTS CAN BE AVOIDED!



01. SAFETY RULES

WARNING

- Hydraulic oil works under pressure and may cause serious injuries if there are any leakages. Periodically check the conservation status of the hoses. If there are any sign of leakage, replace them immediately.
- Before connecting or disconnecting the hydraulic hoses, relief the system pressure by activating the control with the tractor power switched off.



WARNING

- Always keep yourself distant from the active elements of the CRSG/CRI/CRI-R (discs), they are sharp and may cause accidents.
- When performing any service in the discs, use safety gloves on the hands.



WARNING

- Remove the ignition key before performing any type of maintenance in CRSG/CRI/CRI-R. Protect yourself against possible injuries or death by CRSG/CRI/CRI-R unexpected start-up.
- Do not start the tractor up if CRSG/CRI/CRI-R unexpected start-up.

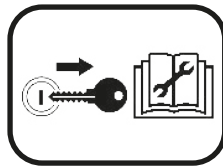









ALCOHOLIC BEVERAGE OR SOME MEDICATIONS MAY CAUSE LOSS OF REFLEXES AND CHANGE THE OPERATOR'S PHYSICAL CONDITIONS. FOR THIS REASON, NEVER OPERATE THIS EQUIPMENT UNDER ANY OF THESE SUBSTANCES.





WARNING

The incorrect handling of the tractor engine can result in serious or fatal accidents. Before using the read carefully the instructions in this manual. Be sure that the person responsible for the operation is instructed about the correct handling and safety and has read and understood the instruction manual concerning this machine.

- 01-  When operating the implement do not allow people to stand close or on the implement.
- 02-  During assembly or disassembly of the discs section use protective gloves.
- 03-  When coupling or uncoupling the hydraulic hose relieve the hydraulic circuit pressure.
- 04-  Check out periodically the hoses condition. Where there is oil emptying change it immediately because the oil works under high pressure and may cause serious damage.
- 05-  Do not use large or daggy clothes because they can get caught on the implement.
- 06-  When you start the tractor engine, be correctly placed at the operator seat and be aware of the correct and safety handling of both tractor and implement. Always place the gearshift crank at the neutral position, turn off the gear of the power command and place the hydraulic commands at the neutral position.
- 07-  Do not turn on the tractor in a closed place without appropriate ventilation because the fumes from the fuel are is bad for health.
- 08-  While maneuvering the tractor to clamp the implement be sure that there is enough space and nobody is too close, maneuver always in slow gear and be ready to brake in case of emergency.



- 09- **⚠** Do not carry out adjustments with the implement working.
- 10- **⚠** When working over hilly areas try to keep the necessary stability. In case of instability reduce the acceleration, turn the wheels to the inclined side of the land and never lift the implement.
- 11- **⚠** Always use the tractor at safe speeds, especially when working in irregular or inclined areas, make sure the tractor is always in gear.
- 12- **⚠** When using the tractor on the road, keep the brake pedal connected.
- 13- **⚠** Do not work with the front tractor light. If there is a tendency to lift up add more weight in the front of the tractor at the front wheels.
- 14- **⚠** When leaving the tractor, place the gearshift at the neutral position and apply the park brake. Never let clamped implements be hitched to the tractor with the hydraulic system at the lifted position.
- 15- **⚠** Drugs and alcohol will affect an operator's alertness and coordination. Do not operate any engine under these conditions.
- 16- **⚠** Explain the operation, inspection and maintenance instructions to those users or operators who can not read.



TRAILED OFFSET DISC HARROW - CRSG DRAG TYPE OFFSET HARROW REMOTE CONTROL - CRI DRAG TYPE OFFSET HARROW REMOTE CONTROL - STRONG - CRI-R

02. COMPONENTS

- 01 - Front disc gang
- 02 - Rear disc gang
- 03 - Central main frame
- 04 - Stabilizer bar
- 05 - Hydraulic cylinder
- 06 - Hydraulic hoses
- 07 - Wheel articulation system
- 08 - Wheel
- 09 - Disc blades
- 10 - Stabilizer rod
- 11 - Stabilizer bar support
- 12 - Transversal bar
- 13 - Hitch beam
- 14 - Hitch shackle
- 15 - Hydraulic hoses support

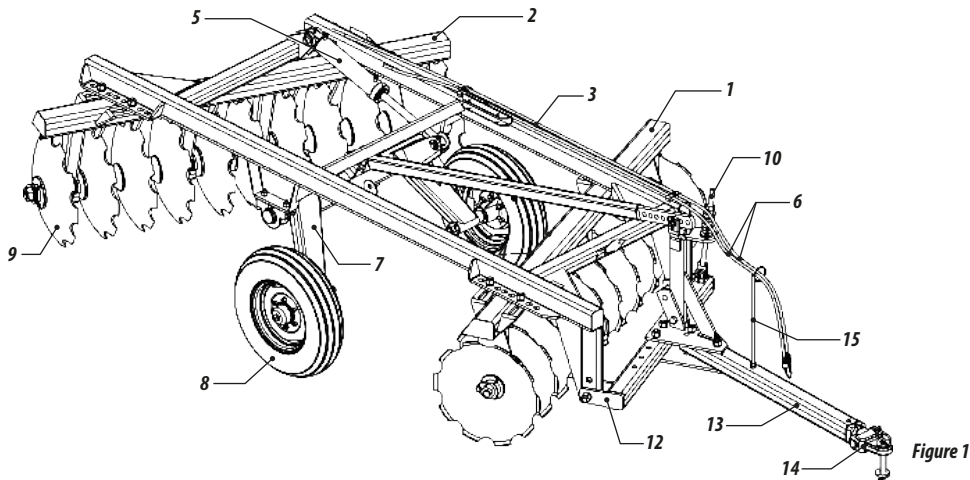

Figure 1



03. TECHNICAL SPECIFICATIONS - CRSG

Table 1

Model	Nr of Discs	Disc Diameter (ø)	Working Width (mm)	Axle Diameter (ø)	Disc Spacing (mm)	Working Depth (mm)	Approx. Weight (Kg)			Required Tractor Power (hp)	Ground Wheels
							24"	26"	28"		
CRSG	12	24" - 26" - 28"	1300	1.5/8"	235	150 - 250	1315	1325	-	60 - 75	Single
CRSG	14	24" - 26" - 28"	1550	1.5/8"	235	150 - 250	1416	1459	-	70 - 80	Single
CRSG	16	24" - 26" - 28"	1750	1.5/8"	235	150 - 250	1476	1607	-	75 - 85	Single
CRSG	18	24" - 26" - 28"	2000	1.5/8"	235	150 - 250	1609	1647	-	85 - 90	Single
CRSG	20	26"	2250	1.5/8"	235	150 - 250	1793	1832	-	90 - 110	Single
CRSG	24	24" - 26" - 28"	2700	1.5/8"	235	150 - 250	1900	2015	-	110 - 120	Single
CRSG	28	24" - 26" - 28"	3200	1.5/8"	235	150 - 250	2250	2293	-	120 - 140	Single
CRSG	32	26" - 28"	3650	1.5/8"	235	150 - 250	-	3400	3500	180 - 192	Dual
CRSG	36	26" - 28"	4200	1.5/8"	235	150 - 250	-	3480	3590	192 - 215	Dual
CRSG	40	26" - 28"	4600	1.5/8"	235	150 - 250	-	3790	3710	215 - 240	Dual
CRSG	44	24" - 26" - 28"	5000	1.5/8"	235	150 - 250	-	4203	4313	240 - 260	Dual
CRSG	48	24" - 26" - 28"	5600	1.5/8"	235	150 - 250	-	4587	4716	240 - 280	Dual
CRSG-L	18	24" - 26" - 28"	2000	1.5/8"	235	150 - 250	1170	1210	-	61 - 79	Single
CRSG-L	20	24" - 26" - 28"	2250	1.5/8"	235	150 - 250	1320	1365	-	61 - 79	Single
CRSG-L	22	24" - 26" - 28"	2450	1.5/8"	235	150 - 250	1430	1480	-	79 - 90	Single
CRSG-L	24	24" - 26" - 28"	2700	1.5/8"	235	150 - 250	1550	1605	-	79 - 90	Single

**Baldan reserves the right to modify any technical specifications without prior notice.
The technical specifications it 's approximate and informed by regular conditions of work.**



04. TECHNICAL SPECIFICATIONS - CRI

Table 2

Model	Nr of Discs	Disc Diameter (ø)	Working Width (mm)	Axle Diameter (ø)	Disc Spacing (mm)	Working Depth (mm)	Approx. Weight (Kg)		Required Tractor Power (hp)	Ground Wheels
							26"	28"		
CRI	12	26" - 28"	1500	1.5/8"	270	150 - 250	1418	1511	73 - 75	Single
CRI	14	26" - 28"	1750	1.5/8"	270	150 - 250	1594	1701	79 - 90	Single
CRI	16	26" - 28"	2000	1.5/8"	270	150 - 250	1850	1890	95 - 110	Single
CRI	18	26" - 28"	2300	1.5/8"	270	150 - 250	2150	2200	110 - 120	Single
CRI	20	26" - 28"	2550	1.5/8"	270	150 - 250	2310	2370	120 - 130	Single
CRI	22	26" - 28"	2850	1.5/8"	270	150 - 250	2428	2597	130 - 145	Single
CRI	24	26" - 28"	3100	1.5/8"	270	150 - 250	2540	2610	145 - 148	Single
CRI	26	26" - 28"	3350	1.5/8"	270	150 - 250	2660	2730	160 - 167	Single
CRI	28	26" - 28"	3650	1.5/8"	270	150 - 250	2730	2810	167 - 180	Single
CRI	32	26" - 28"	4200	1.5/8"	270	150 - 250	2926	3044	180 - 210	Dual
CRI	36	26" - 28"	4700	1.5/8"	270	150 - 250	3226	3560	210 - 216	Dual
CRI	40	26" - 28"	5250	1.5/8"	270	150 - 250	3526	3676	240 - 260	Dual
CRI	44	26" - 28"	5800	1.5/8"	270	150 - 250	4660	4890	260 - 310	Dual

Baldan reserves the right to modify any technical specifications without prior notice.

The technical specifications it 's approximate and informed by regular conditions of work.



05. TECHNICAL SPECIFICATIONS - CRI-R

Table 3

Model	Nr of Discs	Working Width (mm)	Axle Diameter (ø)	Disc Spacing (mm)	Working Depth (mm)	Approx. Weight (Kg)		Required Tractor Power (hp)	Ground Wheels
						28"	30"		
CRI-R	12	1650	2.1/4"	300	150 - 250	1730	-	85 - 96	Single
CRI-R	14	1950	2.1/4"	300	150 - 250	1840	1910	95 - 112	Single
CRI-R	16	2250	2.1/4"	300	150 - 250	2240	2310	114 - 128	Single
CRI-R	18	2550	2.1/4"	300	150 - 250	2460	2530	125 - 144	Single
CRI-R	20	2850	2.1/4"	300	150 - 250	2847	2910	135 - 160	Single
CRI-R	22	3150	2.1/4"	300	150 - 250	2965	3035	150 - 176	Single
CRI-R	24	3450	2.1/4"	300	150 - 250	3090	3160	160 - 192	Single
CRI-R	26	3750	2.1/4"	300	150 - 250	3200	3275	180 - 208	Single

*Baldan reserves the right to modify any technical specifications without prior notice.
The technical specifications it 's approximate and informed by regular conditions of work.*



06. ASSEMBLY

- 01 - Check the amount of parts in the box using the parts list.
- 02 - Before starting the assembly wear gloves.
- 03 - Install on the shaft (#1) the washer from the disc (#2), the nut (#3) locking washer (#4), using the bolt (#5), keep the nut in the same position of the shaft edge.
- 04 - Instal on the shaft (#1) the disc blade (#6) the bearing (#7), another disc blade (#6), spools (#8) then continue the assembly in this sequence as illustrated on the figure 02.
- 05 - On the rear gang install a disc blade with smaller diameter on the edge "A" as illustrated on the drawing 4 - page 6.
- 06 - When you have completed the assemble with all disc blades, spools and bearing, install the convex washer (#9), the nut (#3), then tighten the system.
- 07 - When you are almost finished the tightening procedure adjust the lock (#4), with the convex washer until that the holes are aligned, then lock using the bolt (#5).

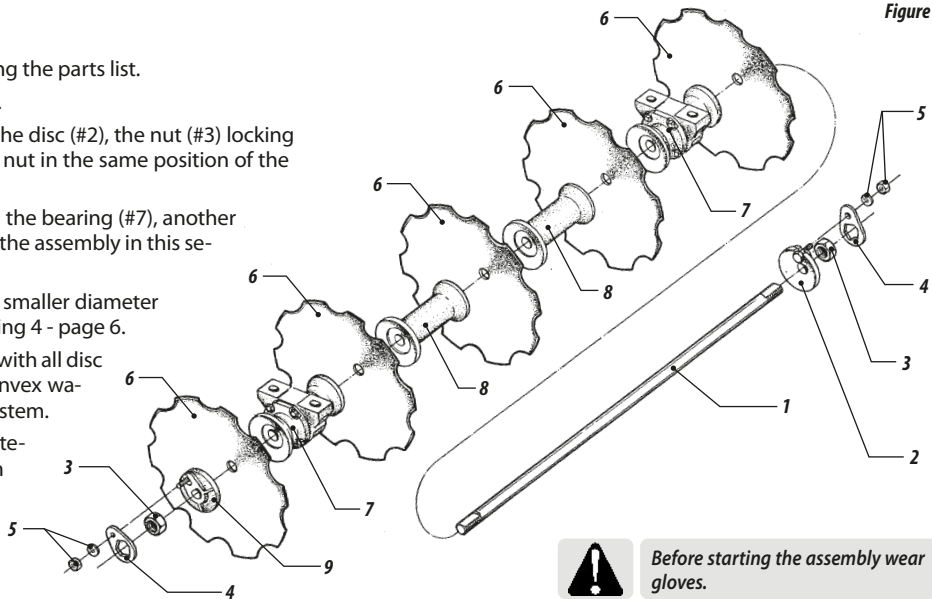

Figure 2



Before starting the assembly wear gloves.



08 - The drawing 4 shows the assembly for each model of harrow.

CRSG/CRI/CRI-R 12 Blades

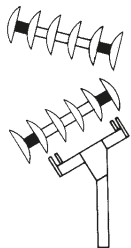

CRSG/CRI/CRI-R14 Blades

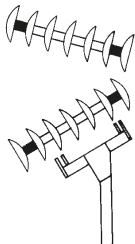

CRSG/CRI/CRI-R16 Blades

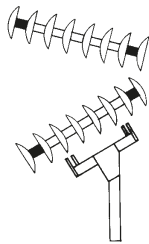

CRSG/CRSL-L/CRI/CRI-R 18 Blades

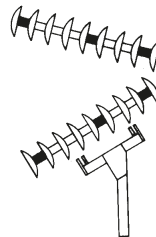

CRSG-L 20 Blades

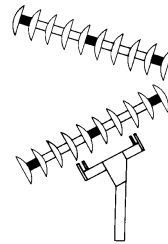

CRSG/CRI/CRI-R 20 Blades

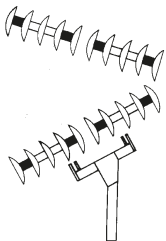

CRSG/CRI/CRI-R 22 Blades

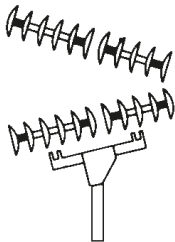

CRSG/CRI/CRI-R 24 Blades

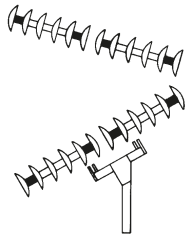

CRSG/CRI/CRI-R 26 Blades

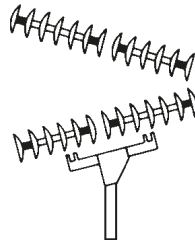

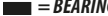
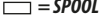
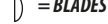
SYMBOL	
	= BEARING
	= SPOOL
	= BLADES

Figures 3



CRSG-L 28 Blades

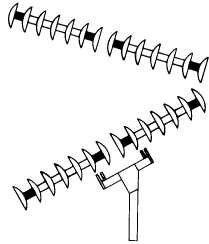

CRSG/CRI 28 Blades

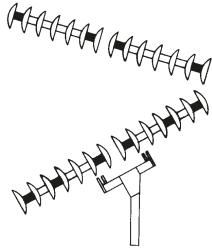

CRSG-L 32 Blades

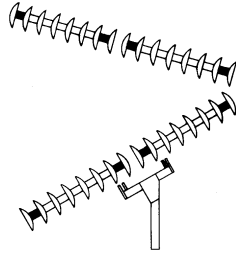

CRSG/CRI 32 Blades

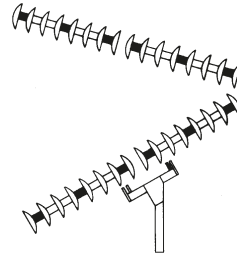

CRSG/CRI 36 Blades

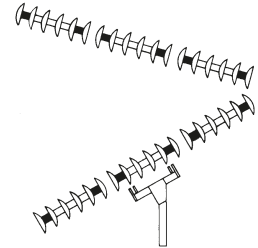

Figures 3

CRSG/CRI 40 Blades

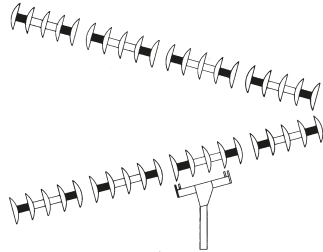

CRSG/CRI 44 Blades

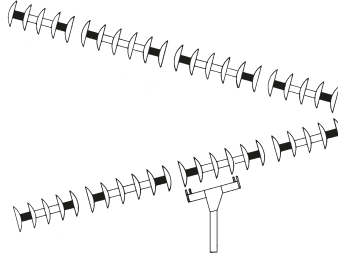

CRSG/CRI 48 Blades

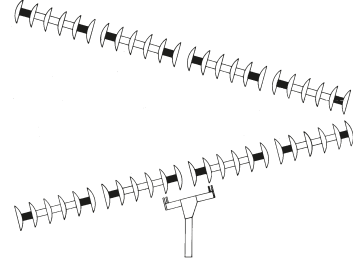
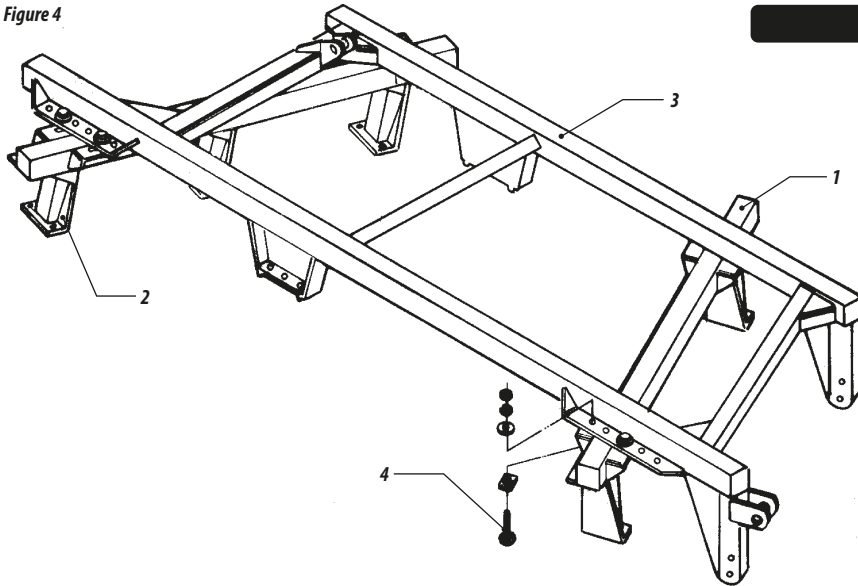

Figure 4



ASSEMBLE OF FRONT AND REAR GANG

- 09 - Insert the front gang (#1 figure 05) and rear (#2), in safety terrain.
- 10 - Install the frame (#3) over the gangs and attach using the bolts (#4), lock (#5), washer (#6) and nut (#7).



11 - Raise the gang front or rear install the blades as illustrated on the drawing 04, checking the bearing and gang holes are aligned, then mount using the bolt (#1 - Drawing 05), be sure the that the support is turned in a concave direction as illustrated on the drawing 06.

12 - Raise the second gang, install the blades as instructed in the point above between the disc concave face the oposite direction to the first gang.

Figure 6

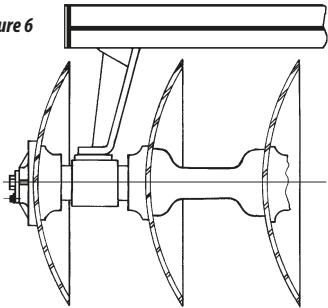

Figure 5

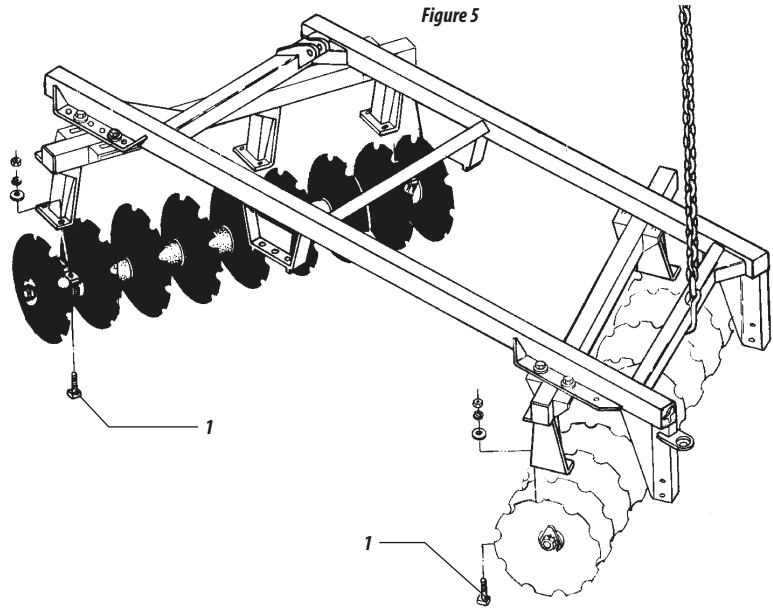
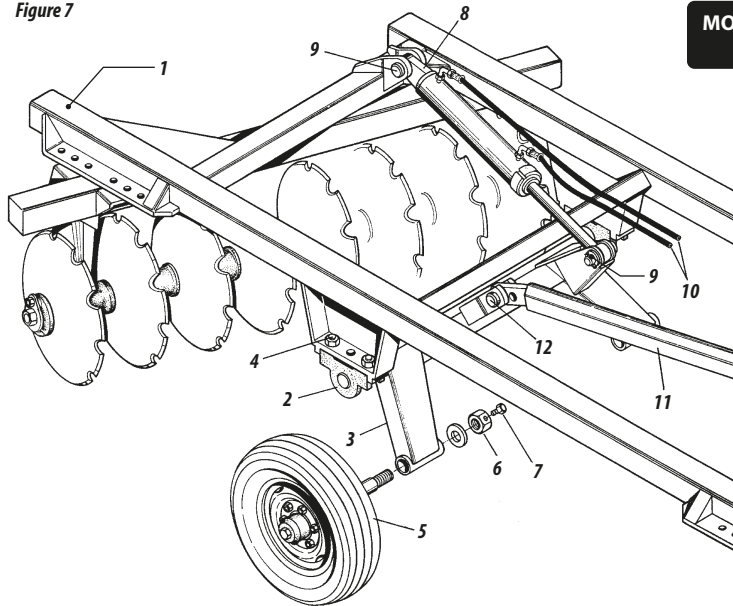

Figure 7



MOUNTING OF THE HYDRAULIC SYSTEM AND ARTICULATING WHEEL ASSEMBLY CRI/CRSG 12 - 28 MODELS WITH SINGLE WHEELS

- 13 - Slide the pillow block hubs, item (2) in the illustration, onto the axles of the wheel articulating system (3) lift the assembly to allow fixation of the hubs to the frame and tighten the bolts.
- MAKE SURE THE CONNECTION OF ITEMS (2) AND (3) ARE TIGHT, OTHERWISE PREMATURE WEAR WILL OCCUR.
- 14 - Therefore the pillow block hub itself has elongated holes to allow a tight fit.
- 15 - Now you can introduce the axles of the mounted wheels into the axles holes on the support, tighten the bolts and make sure, you lock the bolts (6) with the little screw (7).
- 16 - Attach the hydraulic ram or piston, as shown in the illustration, with the base (8), directed to the rear of the implement (9) and attach the hydraulic hoses (10).
- 17 - At this stage, you also attach the stabilizer bar (11) and make sure the bend at the fixation point (12) is directed downwards.

MOUNTING OF THE HYDRAULIC SYSTEM AND THE ARTICULATING WHEEL ASSEMBLY CRI/CRSG 32 - 48 MODELS WITH DUAL WHEELS

- 18 - Slide the pullow block hubs (2) onto the support of the articulation axle (3).
- MAKE SURE THE CONNECTIONS ARE TIGHT, OBSERVING THE ALONGATED HOLES ON THE PART TO ALLOW THIS AND BOLT FIX THE HUBS ON THE MAINS FRAME.
- 19 - Now lift the articulation support of the axle (4) and fix the above axles (3) on them using the pins and lock bolts. Also fix the plates (6) of the articulation support (4) onto the appropriate welded supports of the main frame, using pin and cotter lock pin.
- 20 - Now you can fix the wheel axle onto the supports, with the 4 bolts on each side, as shown in the illustration, as well as the dual wheels. Make sure everything is well tight.
- 21 - Fix the hydraulic cylinders or rams (13), with their bases onto the main frame bar with their respective pins and the cylinder arms onto the support of the articulation axle.
- 22 - Attach the oil distributor, as illustrated, and also the long hoses (18).
- 23 - These hoses are fixed with the bracers (19) to the long main frame bas as shown.
- 24 - We are now ready to fix the transversal stabilizer bar (20) onto the appropriate supporte of the articulation axle (21).

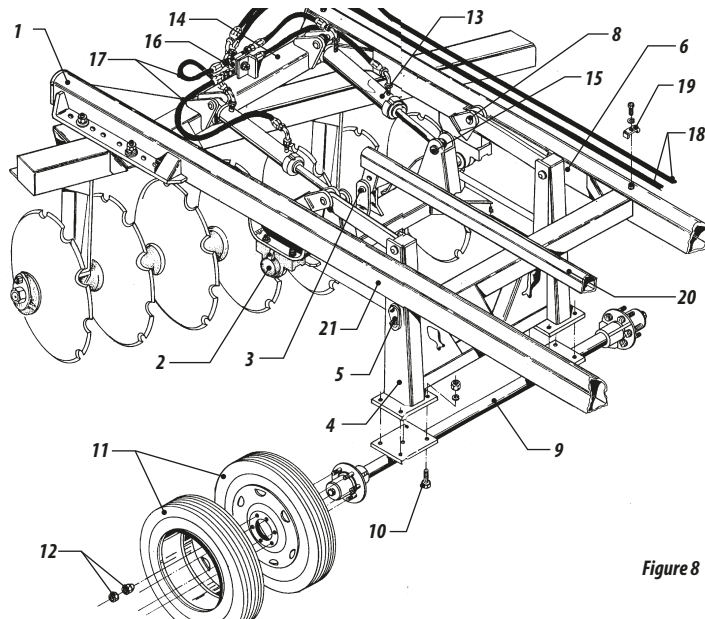

Figure 8



CRI/CRSG 32 - 48 MODELS WITH LARGE SINGLE WHEEL VERSION

- 25 - Instead of dual wheels, BALDAN launched a version with a large 400/60 traction tyre. The advantage of this version is that the same high flotation is provided, while the problem of collecting rock, pieces of wood, or other debris as well as muddy earth between the tyres is, non-existent.
- 26 - The mounting of the hydraulic system and the articulating wheel assembly is the same.
- 27 - MAKE SURE THE CONNECTIONS BETWEEN ITEM (2) AND (3) ARE TIGHT OBSERVING THE ALONGATED HOLES ON THE BOTTOM SIDE OF THE CUSHION BLOCK HUB TO ALLOW THIS AND AVOID PREMATURE WEAR.
- 28 - The design of the system is different for this version and observe the different part number codes when ordering parts.



MOUNTING OF THE HITCH SYSTEM

- 29 - Attach the transversal (1) onto the main frame and fix the ends with the bolts (3) as illustrated in figure 9. There are a top and a bottom hole on the main frame that allow leveling of the tool bar that connects the harrow and the tractor. Use the bottom hole to begin with. It is recommended in the final stage, that this bar stays level when both, tractor and implement, are in the operational position and note supported by the wheels.
- 30 - These holes can optionally be used as a way to obtain more or less depth of the front gangs. If the tractor hitch is higher than the implement, and the drawbar is lined upwards toward the tractor, there is a tendency of the harrow to be lifted in front when in movement, causing less depth in front and transfer of pressure to the rear disc gangs. The opposite causes an inverted affect on the weight distribution.

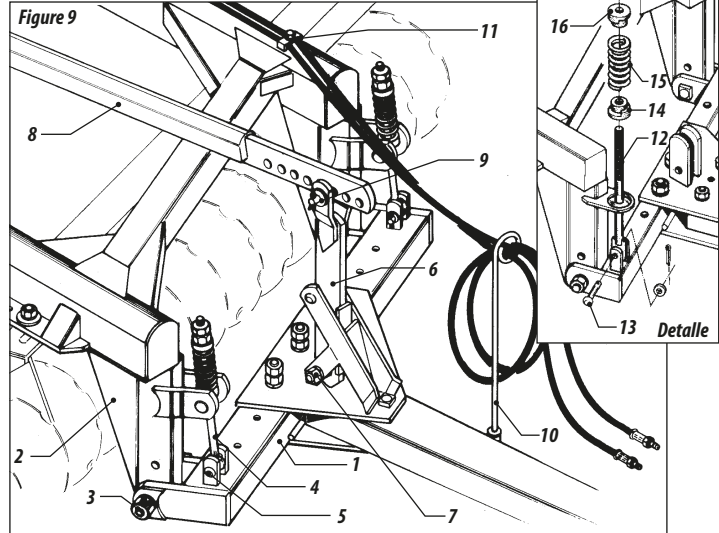



IMPORTANT

The disc scraper (1) must be mounted maintaining a 10mm space from the disc. (Figure 10).

31 - Most tractors have now height adjustment on the tractor hitch that makes levelling of the connection easier.



DO NOT TRANSPORT PEOPLE ON THIS DRAW BAR AT ANY CIRCUMSTANCE!

07. HITCHING TO THE TRACTOR

- 01 - Before doing so, verify if the tractor is ready for the operation and that the front and wheel, weights are in place, according to the manufacturer's specifications.
- 02 - Line the tractor up in front the equipment and adjust the tool bar of the tractor and of the equipment so both come in a straight line (level) for optimum performance.



To connect the hydraulic hoses to the tractor, which is the next step, stop the tractor engine and take all the pressure off by using the tractor commands. Beware for accidents with surrounding people.

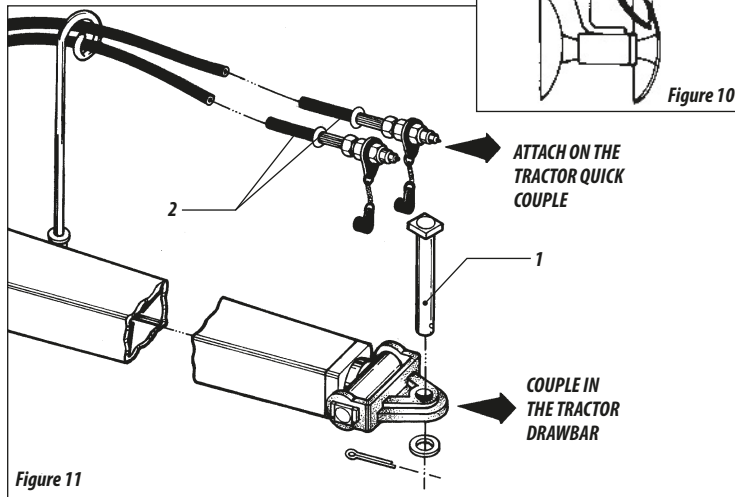
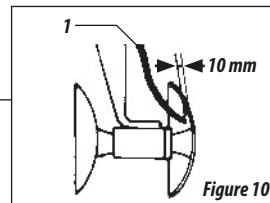

08. ADJUSTMENTS AND OPERATIONS

TRANSPORT

- 01 - To transport the harrow install the rod guide (#1 - Figure 12), on the hydraulic cylinder, lock with the pin (#3) and hairpin (#4).
- 02 - To discing remove the rod guide and lock over the frame.

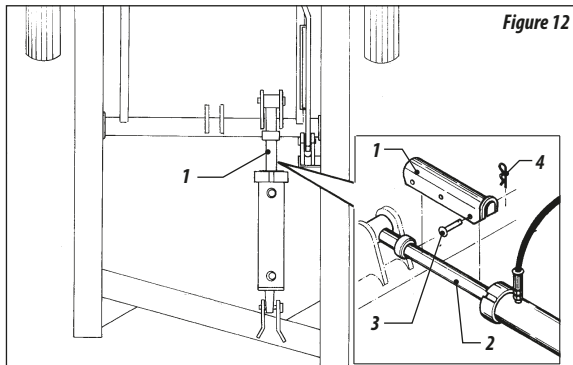
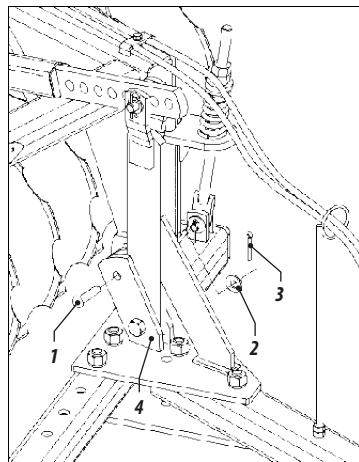

Figure 12

TRANSPORT / WORK

- 01 - Before transporting or working with the harrow, do the following:
- 02 - Remove the pin (1), flat washer (2) and cotter pin (3) from the header (4).

Figure 13



ATTENTION

Do no transport or work the harrow without first removing the pin (1) from the header (4). Failure to observe this will cause serious injury or damage to the equipment.

DISK HARROW GANGS ADJUSTMENTS

- 01 - The following adjustments can be made for a better disk blade penetration. In certain soil conditions, less penetration on gangs may occur, to avoid it adjust the angle of the disc.
 - For hard ground conditions, or when more penetration is desired increase the angling of the discs as illustrated on the figure 14.
 - For normal ground conditions decrease the angling for disking.
- 02 - To increase or decrease the angle of the disc remove the bolts from the frame and adjust to the desired position.
- 03 - The ground wheel helps on the depth control.

Figure 14

Decrease the angling for disking

Increasing the angling for disking

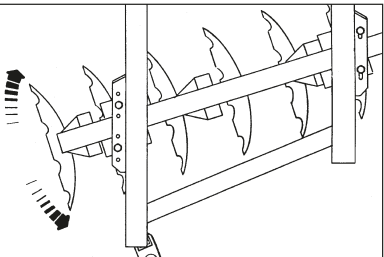

DISPLACEMENT ADJUSTMENT

- 01 - This lateral displacement is used to center the harrow behind the tractor, normally when working in unlevelled areas.
- 02 - The hitch beam also has a regulation system to change the discs penetration.

Available only for CRSG/CRI/CRI-R- 12 / 14 and 16 Discs)

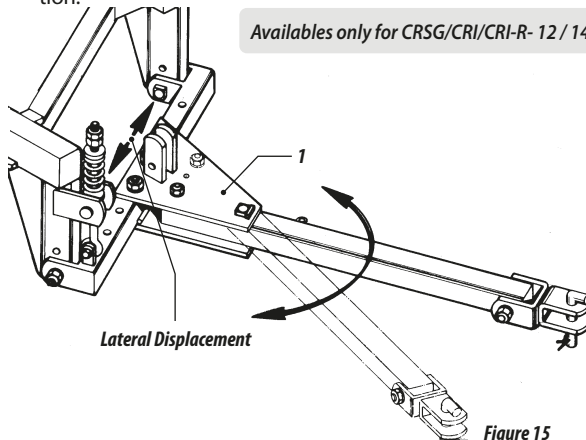
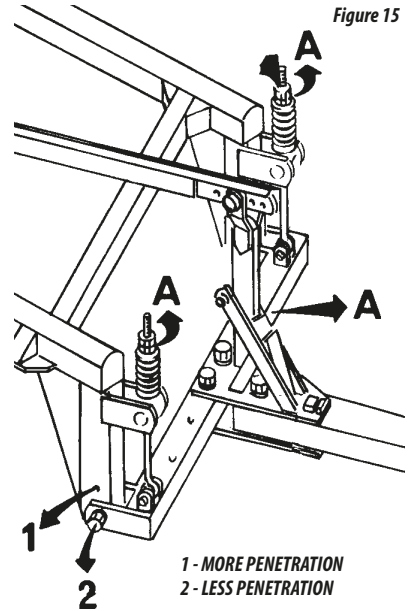

Figure 15

HITCH TRANSVERSAL BAR ADJUSTMENT

- 01 - The transversal bar has two fixation points on the main frame, (1) and (2). It is important that the hitch beam, that connects implement and tractor, is level when in the operational position so the harrow "floats" evenly over the field.
- 02 - If the transversal bar, is attached to the bottom hole (2) while the hitch beam is sloping up to match the tractor hitch, when pulling, the harrow will be "lifted out" of, the ground in front, reducing penetration while the pressure transferred to the rear gang will increase penetration.
- 03 - The opposite will happen when the hitch beam is pulled downwards.
- 04 - These combinations can be used as needed.
- 05 - When working, the nut (A) must maintain a minimum distance of 20 mm from the spring bushing.
- 06 - Also maintain a minimum distance of 20 mm between the stabilizer bar and the hitch beam support (A).
- 07 - The pin (3) is used to elevate the hitch beam when coupling to the tractor.
- 08 - Using the hydraulic system, suspending the harrows wheel, will make the hitch beam also suspend.
- 09 - When the implement is connected to the tractor and you are ready for operation. Take pin (3) out to allow the harrow to flex behind the tractor.



OPERATIONS

01 - Before the beginning of the season use clean off any dirt or grease that may have accumulated on moving parts. This will prevent abrasive action that could cause excessive wear, thoroughly inspect the disk for loose parts and adjust as necessary.

HOW TO START THE DISC

- 02 - Before starting the disc be sure that the harrow is following the contour plowing in order to it stay in left side of the tractor.
- 03 - Do not turn to the right side, as illustrated on drawing 16, the discing area must be in the left side of the tractor.
- 04 - The next drawing show some operations.

DISC FROM OUTSIDE TO INSIDE

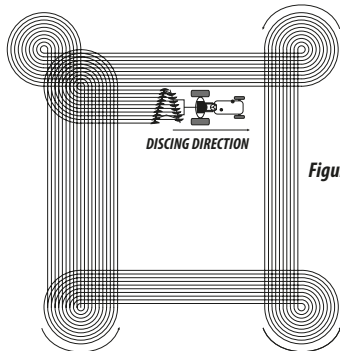

Figures 16

DISC FROM INSIDE TO OUTSIDE

05 - In this direction obtain more accurate discing, when you are working on the edge you should start a new block.

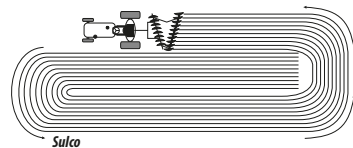

Figures 16

WORKING IN TERRAIN WITH CONTOUR PLOWING

06 - In terrain with contour plowing you should start two blocks each time, be sure that the contour is located on the left side of tractor. When you arrive on half the block you should start a new block to save fuel.

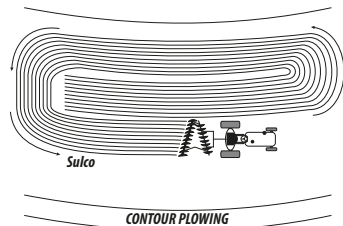

Figures 16



09. LUBRICATION

- 01 - The correct lubrication is very important for providing a high durability and good working of the rotating parts of the engine which will result in years of trouble-free from the disc Harrow.
- 02 - Before running the engine, lubricate all-grease nipples in accordance with the schedule on the next pages. Use good quality lubrication recommended by the manufacturers.

LUBRICATION OF GREASE BEARING

- 03 - Clean all grease nipple and when it is replace damaged.
- 04 - The amount of grease for each bearing is 200 grams.
- 05 - The grease bearing must lubricated every 12 working hours in accordance with the table below.

LUBRICATION OF OIL BATH BEARING

- 06 - When you start to use the harrow check the oil level and the rings from the bearing daily.
- 07 - After several weeks inspect the oil level every 120 working hours.
- 08 - Replace the oil every 1200 working hours. Use oil SAE 90.

TABLE OF EQUIVALENT AND GREASES

<i>Manufacturer</i>	<i>Grease Type</i>
<i>Petrobrás</i>	<i>Lubrax GMA 2</i>
<i>Atlantic</i>	<i>Litholine MP 2</i>
<i>Ipiranga</i>	<i>Super Grasa Ipiranga Ipiranga Super Grasa 2 Ipixflex 2</i>
<i>Castrol</i>	<i>LM 2</i>
<i>Mobil</i>	<i>Mobilgrease MP 77</i>
<i>Texaco</i>	<i>Marfak 2 Agrotex 2</i>
<i>Shell</i>	<i>Retinax A Alvania EP 2</i>
<i>Esso</i>	<i>Multipurpose grease H</i>
<i>Bardahl</i>	<i>Maxlub APG 2 EP</i>

Table 3



If there were other manufacturers or and other. Equivalent trends that are not listed in this. Table, consult the manufacturer's technical manual.



10. LUBRICATION POINTS

Item	Part Name	Number of Grease Nipple							Oil replacement	Lubricate with grease	Re-tighten	Replace	Inspect	MAINTENANCE SCHEDULE
		CRI/CRI-R/CRSG 12, 14 and 16 Discs	CRI/CRI-R/CRSG 18 and 20 Discs	CRI/CRI-R/CRSG 22 Discs	CRI/CRI-R/CRSG 24 and 28 Discs	CRI/CRSG 32 and 36 Discs	CRI/CRSG 40 and 44 Discs	CRSG 48 Discs						
1	Bearing	4	8	8	8	12	16	16		X				12 working hour
2	Articulation shaft pins	2	-	-	-	2	2	2		X				
3	Wheel Ribs	2	2	2	2	2	2	2		X				60 working hour
4	Shaft hub	2	2	2	2	2	2	2		X				
5	Clevis	1	1	1	1	2	2	2		X				
6	Rod	1	1	1	1	1	1	1		X				
7	Hitch point	1	1	1	1	1	1	1		X				
8	Support Plate	4	-	-	-	4	4	4		X				
9	Articulation												X	120 working hour
10	Hydraulic System												X	
11	Oil from the Bearing										X			
12	Nuts, Bolts, Pin								X					1200 working hour
13	Bearing											X		1500 working hour
14	Seal Ring											X		
15	Bearing											X		When Necessary
16	Blades / Tyre											X		



Figure 17

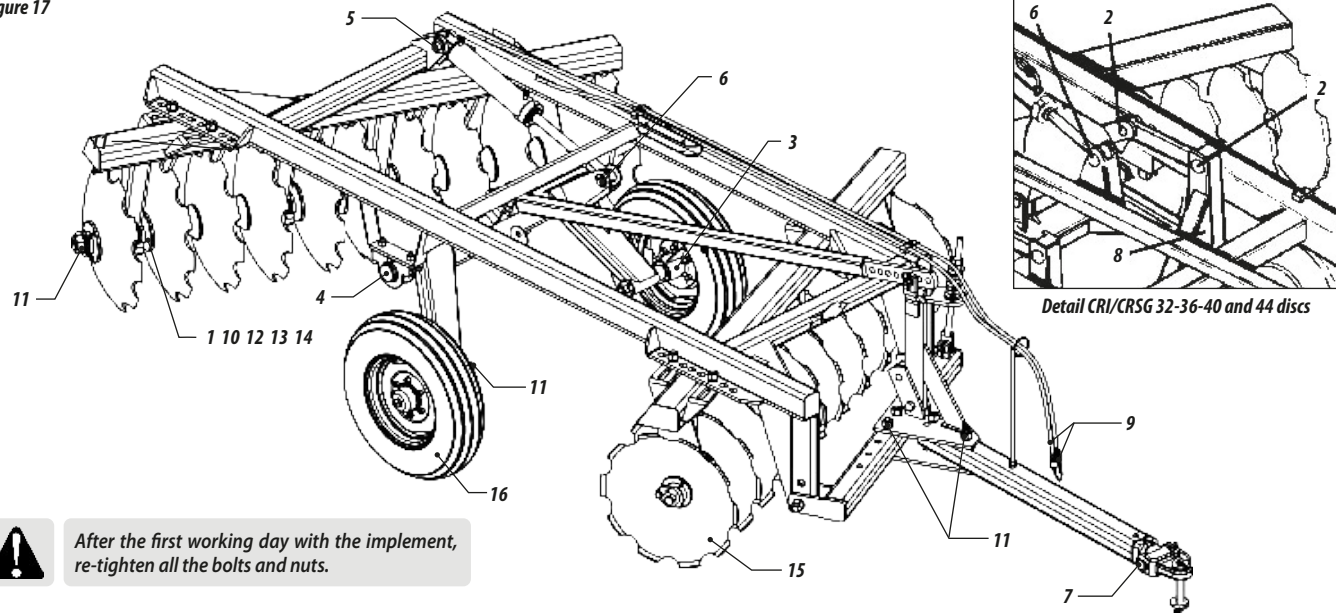

Detail CRI/CRSG 32-36-40 and 44 discs



After the first working day with the implement, re-tighten all the bolts and nuts.



11. BEARING ADJUSTMENTS

• When the bearings present looseness, adjust them on the following way:

- 01 - Take the washer out item 1 figure 18.
- 02 - Release the bolts item 2 and take the lid item 3 out.
- 03 - Take the joints 1 or 2 item 4, out of the lid bearing. Put it again and tighten it.
- 04 - If the looseness is still, turn the lid item 3, to increase the adjustment after assemble the lid on the bearing with as many joints as it is necessary.
- 05 - The bearing should turn freely, that is, without radial and axial looseness.

12. CLEANING

- 01 - When the grade remains inactive for a long period, make a general cleaning, check if the painting didn't get spoiled. If it happened, pass a protecting oil and lubricate it totally. Check the discs, repaint them and pass a protecting oil on them.

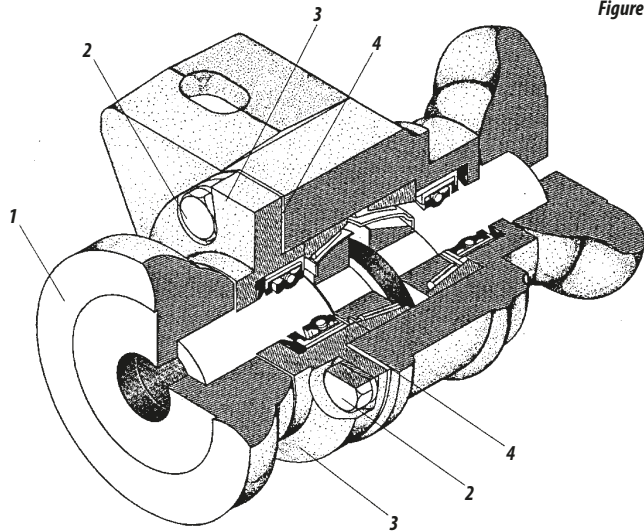

Figure 18



NOTE

Don't assemble the bearing without a joint.



13. HOURLY PRODUCTION OF THE CRSG / CRI / CRI-R

01 - To calculate daily production of the CRSG / CRI / CRI-R level harrow, use the following formula:

$$A = \frac{L \times V \times F}{X}$$

FORMULA DATA:

A = Area to be worked

L = Cutting width (meters)

V = Average tractor (meters)

F = Work hours

X = Number of hectares (10.000 m²)

Ex: A harrow with 24 discs, how many hectares can it harrow in one hour at an average speed of 7 km per hour.

A = ?

L = 3,10m

V = 7.000m/h

F = 0,90

X = 10.000m²

$$A = \frac{3,10 \times 7.000 \times 0,9}{10.000} = 1,95 \text{ Ha/h}$$



02 - APPROXIMATE HOURLY PRODUCTION TABLE.

Model	Working Width (mm)	Average Speed (m/h)	Working Hours	Approximate Production
				Hectares
CRSG - 12	1,30	7000	0,90	0,81
CRSG - 14	1,55	7000	0,90	0,97
CRSG - 16	1,75	7000	0,90	1,10
CRSG - 18	2,00	7000	0,90	1,26
CRSG - 20	2,25	7000	0,90	1,41
CRSG - 24	2,70	7000	0,90	1,70
CRSG - 28	3,20	7000	0,90	2,01
CRSG - 32	3,65	7000	0,90	2,29
CRSG - 36	4,20	7000	0,90	2,65
CRSG - 40	4,60	7000	0,90	2,89
CRSG - 44	5,00	7000	0,90	3,15
CRSG - 48	5,60	7000	0,90	3,52

Table 5

Model	Working Width (mm)	Average Speed (m/h)	Working Hours	Approximate Production
				Hectares
CRI - 12	1,50	7000	0,90	0,94
CRI - 14	1,75	7000	0,90	1,45
CRI - 16	2,00	7000	0,90	1,26
CRI - 18	2,30	7000	0,90	1,45
CRI - 20	2,55	7000	0,90	1,60
CRI - 22	2,85	7000	0,90	1,79
CRI - 24	3,10	7000	0,90	1,95
CRI - 26	3,35	7000	0,90	2,11
CRI - 28	3,65	7000	0,90	2,30
CRI - 32	4,20	7000	0,90	2,65
CRI - 36	4,70	7000	0,90	2,96
CRI - 40	5,25	7000	0,90	3,30
CRI - 44	5,80	7000	0,90	3,65

Table 6



Model	Working Width (mm)	Average Speed (m/h)	Working Hours	Approximate Production
				Hectares
CRI-R - 12	1,65	7000	0,90	1,04
CRI-R - 14	1,95	7000	0,90	1,23
CRI-R - 16	2,25	7000	0,90	1,42
CRI-R - 18	2,55	7000	0,90	1,60
CRI-R - 20	2,85	7000	0,90	1,80
CRI-R - 22	3,15	7000	0,90	1,98
CRI-R - 24	3,45	7000	0,90	2,17
CRI-R - 26	3,75	7000	0,90	2,37

Table 7

01 - The formula to calculate the approximate production refers to the work area performed by the harrow.

02 - If it is wished to know many hours it will take to harrow a known area, just divide the area by the hourly production of the equipment.

03 - **Example:** What is the time (X) necessary for a harrow with 24 discs to prepare 35 hectares at a medium tractor speed of 7 Km/hour? $\frac{X = 35 \text{ Ha}}{1,95} = 18 \text{ hours approximately}$

04 - Daily production varies with the pace of work such as moist or dry soils, topography, inadequate machine adjustments etc.

05 - These factors are not considered in the table which are based on normal working conditions.



14. IDENTIFICATION

01 - In order to refer parts catalogues or apply technical support from Baldan, always indicate model (1), serial number (2), manufacture date (3) located on the identification tag.

ALWAYS REQUIRE BALDAN ORIGINAL PARTS

- Look in your local, a reseller BALDAN, he will have in stock genuine parts.



PUBLICATIONS

Code: 6055010377-2
CPT: CRSG14217



WARNING

The draws contained in this instruction manual are merely illustrative.



CONTACT

*In case of doubt do not operate the equipment, please contact our After-sales Service.
Phone: 0800-152577
e-mail: posvenda@baldan.com.br*



CERTIFICATE OF WARRANTY

- 01 - **BALDAN IMPLEMENTOS AGRÍCOLAS S/A**, guarantee the normal operation of the product for a 6 (six) months period dated from the dealer's bill of sale to the first final customer.
- 02 - During this period, **Baldan** compromise itself to repair the material or manufacturing defects, but the labour, the freight and other expenses are the dealer's responsibility.
- 03 - At the guarantee period, all the request and replacement of any defective part must be made to the dealer of the region, which will send the defective part for analysis at **Baldan**.
- 04 - When this procedure won't be possible and the dealer couldn't have the ability to solve the problem, the dealer can ask for **Baldan's Technical Assistance** using the specific form delivered to them.
- 05 - After the analysis of the items replaced by **Baldan Technical Assistance** and if we conclude that it wasn't a guarantee problem, then the dealer will be the responsible for all costs related to the replacement; as well as material expenses, travel including accommodation and meals, also the accessories, lubricant used or any other expenses after having called the Technical Assistance. And, withal, the company Baldan is authorized to issue the billing in name of the respective reseller.
- 06 - Any repair made to the product which is in warranty period by the dealer, will only be authorized by Baldan after budget previous presentation describing pieces and labour to be accomplished.
- 07 - It is out of this term the product which has repairs or modifications not made by dealers from Baldan's network, as well as pieces applications or not authentic components to the product by the user.

- 08 - This certificate of guarantee will become invalid when notice that the damage or defect is the result of incorrect use of the product, of instructions non-observance or operator's inexperience.
- 09 - It's stipulated that this guarantee doesn't cover tires, polyethylene deposits, universal joints, hydraulic components, etc, which equipments are guaranteed by their manufacturers.
- 10 - The material or manufacture defects, object of this certificate of guarantee, will not be, by any hypothesis, reason for cancellation of the contract of sale, or indemnity of any kind.
- 11 - For a warranty solicitation to the distributor, you have to proceed in the following manner:
- 12 - Send the technical informe detailed telling the problem (technical assistance request form to the client), you can find it send us an email to **after-sales@aldan.com.br** or accessing our website.
- 13 - If it's possible send films and photos from the requested spare parts.
- 14 - To point at the form: serial number, manufacture year, etc, that is, all information asked at the form. The damage spare parts should be available for analysis of the the after sales department in a future visit (in case of requested).
- 15 - **Aldan** keeps the right of changing and or improve the technical characteristics of its products, without notice and without the obligation of act like this way with its previously manufactured products.

INSPECTION AND DELIVERY CERTIFICATE

- **SERVICE BEFORE THE DELIVERY:** This equipment was very carefully prepared by the dealer's organization, inspected in all its parts in agreement with the manufacture's prescription.
- **DELIVERY SERVICE:** The user was informed about the current guarantee terms and instructed about maintenance care and utilization.
- I confirm that I was informed about the current guarantee terms and instructed about the correct utilization and maintenance of this product.

Product: _____ *Serial number:* _____

Date: _____ *Bill of sale:* _____ *Store:* _____

City: _____ *State:* _____ *Zip code:* _____

Owner: _____ *Phone:* _____

Adress: _____ *Number:* _____

City: _____ *State:* _____

E-mail: _____ *Date of sale:* _____

INSPECTION AND DELIVERY CERTIFICATE

- **SERVICE BEFORE THE DELIVERY:** This equipment was very carefully prepared by the dealer's organization, inspected in all its parts in agreement with the manufacture's prescription.
- **DELIVERY SERVICE:** The user was informed about the current guarantee terms and instructed about maintenance care and utilization.
- I confirm that I was informed about the current guarantee terms and instructed about the correct utilization and maintenance of this product.

Product: _____ *Serial number:* _____

Date: _____ *Bill of sale:* _____ *Store:* _____

City: _____ *State:* _____ *Zip code:* _____

Owner: _____ *Phone:* _____

Adress: _____ *Number:* _____

City: _____ *State:* _____

E-mail: _____ *Date of sale:* _____

INSPECTION AND DELIVERY CERTIFICATE

- **SERVICE BEFORE THE DELIVERY:** This equipment was very carefully prepared by the dealer's organization, inspected in all its parts in agreement with the manufacture's prescription.
- **DELIVERY SERVICE:** The user was informed about the current guarantee terms and instructed about maintenance care and utilization.
- I confirm that I was informed about the current guarantee terms and instructed about the correct utilization and maintenance of this product.

Product: _____ Serial number: _____

Date: _____ Bill of sale: _____ Store: _____

City: _____ State: _____ Zip code: _____

Owner: _____ Phone: _____

Adress: _____ Number: _____

City: _____ State: _____

E-mail: _____ Date of sale: _____

3ª Page - Manufacturer

Please send this filled copy to Baldan, until 15 days after the purchase.

Signature / Store's stamp _____



6 0 5 5 0 1 0 3 7 7 2



Baldan



BALDAN IMPLEMENTOS AGRÍCOLAS S/A.

Av. Baldan, 1500 | Nova Matão | CEP: 15993-000 | Matão-SP | Brasil

Phone / Telefono: (0**16) 3221-6500 | Fax: (0**16) 3382-6500

Home Page: www.baldan.com.br | e-mail: sac@baldan.com.br

Export - Phone / Telefono: 55 16 3221-6500 | Fax: 55 16 3382-4212 | 3382-2480

e-mail: export@baldan.com.br