

Instruction Manual



CRSG 12-28
Trailed Offset Disc Harrow

 **BALDAN**

■ Presentation

We appreciate the preference and would like to congratulate you for excellent choice you just made, since you have acquired a product manufactured with **BALDAN**



IMPLEMENTOS AGRÍCOLAS S/A technology.

This manual will guide you through the procedures required since its acquisition until operational procedures of usage, safety and maintenance.

BALDAN assures that it has delivered this implement for resale in full and in perfect conditions.

Resale was responsible for the custody and maintenance during the period in its possession, and also for the assembly, retightening, lubrication and overhaul.

During the technical delivery, dealer should guide the user regarding maintenance, safety, their obligations in eventual technical assistance, strict compliance with the warranty term and reading the instructions manual.

Any technical assistance request while in warranty must be made to the dealer from whom you have purchased it.

We reiterate the need for a careful read of the warranty certificate and compliance of all items from this manual, because by doing so you will increase the life of your device.

Instruction Manual



CRSG 12-28

Trailled Offset Disc Harrow

BALDAN IMPLEMENTOS AGRÍCOLAS S/A.
CNPJ: 52.311.347/0009-06
Insc. Est.: 441.016.953.110



Scan the QR Code on the identification plate of your device and access this Instruction Manual online.

 **BALDAN**

▪ Index

BALDAN WARRANTY	07
GENERAL INFORMATION	08
<i>To the owner</i>	<i>08</i>
SAFETY RULES.....	09
<i>To the operator.....</i>	<i>09 - 12</i>
WARNINGS	13 - 14
COMPONENTS.....	15
<i>CRSG - Trailed Offset Disc Harrow</i>	<i>15</i>
DIMENSIONS	16
<i>CRSG - Trailed Offset Disc Harrow</i>	<i>16</i>
SPECIFICATIONS	17
<i>CRSG - Trailed Offset Disc Harrow</i>	<i>17</i>
ASSEMBLY	18
<i>Wrench set</i>	<i>18</i>
<i>Assembly disc sections.....</i>	<i>19</i>
<i>Assembly disc sections - CRSG 12, 14 and 16 discs.....</i>	<i>20</i>
<i>Assembly disc sections - CRSG 18, 20 and 22 discs.....</i>	<i>21</i>
<i>Assembly disc sections - CRSG 24 and 28 discs.....</i>	<i>22</i>
<i>Assembling frames to the studs.....</i>	<i>23</i>
<i>Assembling disc sections on the frames.....</i>	<i>24</i>
<i>Assembling the wipers.....</i>	<i>25</i>
<i>Assembling wheel shaft holder</i>	<i>26</i>
<i>Assembling tires</i>	<i>27</i>
<i>Assembling hydraulic cylinder</i>	<i>28</i>
<i>Assembling coupling head</i>	<i>29</i>
<i>Assembling stabilizer bar</i>	<i>30</i>
<i>Assembling hydraulic hoses</i>	<i>31</i>
HICHT.....	32
<i>Harrow coupling to tractor drawbar</i>	<i>32</i>
LEVELING	33
<i>Harrow leveling - Part I.....</i>	<i>33</i>
<i>Harrow leveling - Part II.....</i>	<i>34</i>
ADJUSTMENTS	35
<i>Adjustment for transport</i>	<i>35</i>
<i>Harrow opening adjustment.....</i>	<i>36</i>
<i>Working depth adjustment.....</i>	<i>37</i>
<i>Harrow displacement regulation - Part I</i>	<i>38</i>
<i>Harrow displacement regulation - Part II</i>	<i>39</i>

▪ Index

OPERATIONS.....	40
<i>Recommendations for operation - Part I</i>	40
<i>Recommendations for operation - Part II.....</i>	41
<i>Direction of maneuvers</i>	41
<i>How to start harrowing</i>	42
<i>Harrow in from the outside in.....</i>	42
<i>Harrow in from the inside out.....</i>	43
<i>Fields with contour lines.....</i>	43
CALCULATIONS.....	44
<i>Approximate hourly production - Part I.....</i>	44
<i>Approximate hourly production - Part II.....</i>	45
MAINTENANCE	46
<i>Tire pressure.....</i>	46
<i>Lubrication</i>	47
<i>Lubrication every 24 working hours</i>	48
<i>Self-lubricating bushings</i>	48
<i>Oil bearing.....</i>	49
<i>Grease bearing.....</i>	49
<i>Operational maintenance.....</i>	50
<i>Care.....</i>	51
<i>General cleaning - Part I.....</i>	51
<i>General cleaning - Part II.....</i>	52
<i>Conservation of the harrow - Part I.....</i>	52
<i>Conservation of the harrow - Part II.....</i>	52
<i>Conservation of the harrow - Part III.....</i>	53
LIFTING.....	54
<i>Lifting points.....</i>	54
OPTIONAL.....	55
<i>Optional accessories.....</i>	55
IDENTIFICATION.....	56
<i>Identification plate.....</i>	56
<i>Product identification</i>	57
NOTES.....	58-59
CERTIFICATE.....	60
<i>Guarantee certificate.....</i>	60-66

▪ Baldan Warranty

BALDAN IMPLEMENTOS AGRÍCOLAS S/A ensures the dealer normal performance of the implement for a period of six (6) months as of the delivery date on the retail invoice to the first final consumer.

During this period, **BALDAN** undertakes to repair defects in material and/or of manufacture of its liability, including labor, freight and other expenses of the dealer's liability.

In the warranty period, request and replacement of eventual defective parts shall be made to the dealer of the area, who will submit the faulty piece for **BALDAN** analysis.

When this procedure is not possible and the resolving capacity of the dealer is exhausted, the dealer will request the support of **BALDAN** Technical Assistance through a specific form distributed to dealers.

After analyzing the replaced items by **BALDAN** Technical Assistance, and concluding that it is not a warranty, then the dealer will be responsible for the costs related to the replacement; as well as material expenses, travel including accommodation and meals, accessories, lubricant used and other expenses arising from the call out to Technical Assistance, and **BALDAN** company is authorized to carry the respective invoice in the name of the resale.

Any repair carried out in the product within the dealer warranty deadline will only be authorized by **BALDAN** upon previous budget presentation describing parts and workforce to be executed.

The product is excluded from this term if it is repaired or modified by representatives not belonging to the **BALDAN** dealer network, as well as the application of non-genuine parts or components to the user's product.

This warranty is void where it is found that the defect or damage is caused by improper use of the product, failure to follow instructions or inexperience of the operator.

It is agreed that this warranty does not cover tires, polyethylene tanks, cardan shafts, hydraulic components, etc., which are equipment guaranteed by their manufacturers.

Manufacturing and/or material defects, object of this warranty term, will not constitute, under any circumstances, grounds for termination of a purchase agreement, or for indemnification of any nature.

BALDAN reserves the right to change and/or perfect the technical characteristics of its products, without previous notice, and without obligation to proceed in the same way with the products previously manufactured.

▪ General Information

• To the owner

BALDAN IMPLEMENTOS AGRÍCOLAS S/A is not responsible for any damaged caused by accident due to usage, transportation, or in the improper or incorrect transportation of its implement, whether by negligence and/or inexperience of any person.

Only people with complete knowledge of the tractor and the implement should carry their transportation and operation.

BALDAN is not responsible for any damaged caused in unpredictable or unrelated situations to the normal use of the implement.

The incorrect handling of this equipment may result in severe or fatal accidents. Before starting the equipment, carefully read the instructions contained in this manual. Make sure that the person responsible for the operation is instructed as the correct and safe handling. Also make sure that the operator has read and understood the instructions manual of the product.

ATTENTION

NR-31 - SAFETY AND HEALTH AT WORK IN AGRICULTURE, LIVESTOCK FORESTRY, FOREST EXPLORATION AND AQUACULTURE.

The purpose of this Regulatory Standard is to establish the precepts to be observed in the organization and in the work environment, in a manner compatible with the planning and development of agriculture, livestock, forestry and aquaculture activities with the safety and health and environment work environment.

MR. OWNER OR OPERATOR OF THE EQUIPMENT.

Read and carefully comply with provisions of NR-31.

For more information, refer to the site and read in full NR-31.
<http://portal.mte.gov.br/legislacao/normas-regulamentadoras-1.htm>

▪ Safety Rules

- To the operator



THIS SYMBOL INDICATES IMPORTANT SAFETY WARNING. IN THIS MANUAL, WHENEVER YOU FIND IT, READ THE FOLLOWING MESSAGE CAREFULLY AND PAY ATTENTION TO THE POSSIBILITY OF PERSONAL ACCIDENTS.

 **ATTENTION**

Carefully read the instructions manual to learn about the recommended safety practices.

 **ATTENTION**

Only start to operate the tractor when you are properly seated and with the seat belt locked.

 **ATTENTION**

Do not transport people or equipment on the tractor.

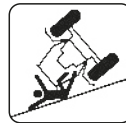
 **ATTENTION**

There are risks of severe injuries due to tipping when working in sloped terrains. Do not over speed.

 **ATTENTION**

Do not work with the tractor if the front has insufficient ballast to the rear equipment. Should there be a trend to lift, add weights or ballasts to the front or the front wheels.

 **ATTENTION**

Before performing any maintenance in your equipment, make sure it is properly stopped. Avoid being run over.

 **ATTENTION**

Be careful when handling the CRSG support leg, as there is a risk of accidents.

▪ Safety Rules

! ATTENTION FOLLOW ALL RECOMMENDATIONS, WARNINGS AND SAFE PRACTICES RECOMMENDED IN THIS MANUAL, UNDERSTAND THE IMPORTANCE OF YOUR SAFETY. ACCIDENTS MAY LEAD TO DISABILITY OR INCLUDING DEATH. REMEMBER, ACCIDENTS CAN BE AVOIDED!

! ATTENTION



Do not make adjustments with the CRSG in operation. When doing any service on the CRSG, turn off the tractor first. Use appropriate tools.

! ATTENTION

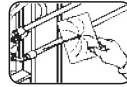

When looking for possible leaks in hoses, use a cardboard or wood, never use your hands. Avoid fluid incision into the skin.

! ATTENTION



When transporting the CRSG, do not exceed the speed of 25Km/h or 15 MPH, avoiding risks of damages and accidents.

! ATTENTION

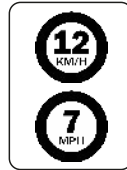

When working with the CRSG, do not exceed the speed of 12Km/h or 7 MPH, avoiding risk of damages and accidents.

! ATTENTION

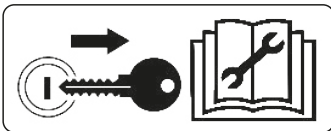

Remove the ignition key before performing any maintenance on the CRSG. Protect yourself from possible injury or death caused by an unforeseen CRSG start up. If the CRSG is not properly engaged, do not start the tractor.

! ATTENTION



Hydraulic oil works under pressure and may cause serious injuries if there are any leakages. Periodically check hoses for conservation. If there are any sign of leakage, replace them immediately. Before connecting or disconnecting hydraulic hoses, relief system pressure by activating the command with the tractor power switched off.

▪ Safety Rules**! ATTENTION**

Always maintain places of access and work free of residues such as oil or grease to prevent accidents.

! ATTENTION

Before commencing work or transportation to CRSG, check for any nearby persons or obstructions.

! ATTENTION

Avoid heating parts near the fluid lines. Heating may generate fragility in the material, rupture and exit of the pressurized fluid, causing burns and injuries

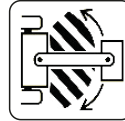
! ATTENTION

Keep the joint area free while the CRSG is in operation. In closed curves, prevent tractor wheels from touching the head.

! ATTENTION

Never weld the tire-mounted wheel, the heat may cause increased air pressure and cause the tire to burst.

When filling the tire, position yourself besides the tire, never in front of it. To inflate a tire, always use a containment device (inflation cage).

! ATTENTION

Always stay away from the active elements of the CRSG (discs), they are sharp and can cause accidents. When performing any service in the discs, wear safety gloves.

! ATTENTION

Disposing of waste improperly affects the environment and the environment, as it will pollute rivers, canals or the soil. Inform yourself about the proper way of recycling or disposing residues.

PROTECT THE ENVIRONMENT!

▪ Safety Rules

• PPE Equipment

ATTENTION | DO NOT WORK WITH THE CRSG WITHOUT WEARING PPE (SAFETY EQUIPMENT). IGNORING THIS WARNING MAY CAUSE DAMAGES TO HEALTH, SEVERE ACCIDENTS OR DEATH.

When performing certain procedures with the **CRSG**, wear the following Safety Equipment (PPE):

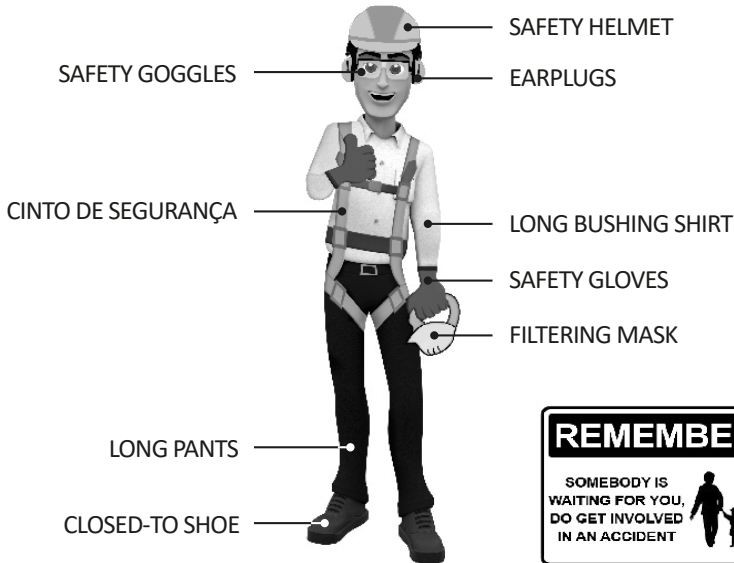

















! IMPORTANT

Safety practice must be performed in all stages of working with the CRSG, thus avoiding accidents such as impact of objects, fall, noise, cuts and ergonomics, in other words, the person responsible for operating the CRSG is subject to internal and external bodily damage.

OBSERVATION | All PPEs (Safety Equipment) should have certificate of authenticity.



▪ Warnings

-  When operating with the CRSG, do not let people stay close or on it.
-  When performing any maintenance service, use PPEs equipment.
-  Before connecting or disconnecting hydraulic hoses, relief the system pressure by activating the command with the tractor power switched off.
-  Periodically check the conservation status of the hydraulic hoses. If there are indications of oil leakage, replace the hose immediately, because the oil works under high pressure and may cause serious accidents.
-  Do not wear loose clothing, as they may get caught in the CRSG.
-  When operating the tractor engine, be properly seated in the operator's seat and be aware of the full knowledge of the correct and safe handling of both the tractor and the CRSG. Always put the gear shift in neutral position, unplug the power take-off gear switch and place the hydraulic controls in neutral position.
-  Do not start the motor in a closed environment or with no proper ventilation since the exhaust gases are harmful to health.
-  When maneuvering the tractor to the CRSG hitch, make sure you have adequate clearance and that there are no people too close, always maneuver at idle and be prepared to brake in an emergency.
-  Do not make adjustments with the CRSG in operation.
-  When working in sloped terrains, proceed with precautions, always trying to maintain the required stability. In case of imbalance, reduce acceleration, turn the wheels to the slope side of the terrain and never lift the CRSG.
-  Always conduct the tractor in speeds compatible to the safety, especially during works in bumpy lands or slopes, keep the tractor always engaged.
-  When driving the tractor in highways, keep the brake pedals interconnected.
-  Do not work with the tractor with light rear. If the rear has a tendency to lift, add more weights on the rear wheels.
-  When leaving the tractor, put the gear lever in neutral position and apply the parking brake. Never leave the CRSG on the tractor in the raised position of the hydraulic system.
-  The CRSG must be turned off before any maintenance work.
-  Do not travel on highways especially at night. Use warning signs throughout the course
-  If you need to travel with the CRSG on highways, consult traffic authorities.

▪ Warnings

- ⚠ The CRSG must not be operated by untrained people, i.e. people who do not know to properly operate it.
- ⚠ Do not transport or work with the CRSG near obstacles, rivers or streams.
- ⚠ The transportation of people on self-propelled machines and implements is forbidden.
- ⚠ Changes to the original CRSG characteristics are not allowed, as they may alter the safety, operation and life of the CRSG.
- ⚠ Read all safety information contained in this manual and the CRSG carefully.
- ⚠ Read or explain all the procedures of this manual to the operator who cannot read.
- ⚠ Always check that the CRSG is in perfect conditions of use. In the event of any irregularity that may interfere with the operation of the CRSG, ensure proper maintenance before any work or transportation.
- ⚠ Maintenance and especially inspection in CRSG risk areas should be done only by a qualified or qualified worker, observing all safety guidelines. Before starting maintenance, disconnect all CRSG drive systems.
- ⚠ Periodically check all components of the CRSG before using it.
- ⚠ Due to the equipment used and work conditions on field or in maintenance areas, precautions are required. Baldan has no direct control over precautions, so it is the owner's responsibility to implement safety procedures while working with CRSG.
- ⚠ Check the recommended minimum tractor power for each CRSG model. Only use tractor with power and ballast compatible with the load and topography of the terrain.
- ⚠ When transporting the CRSG, travel at speeds compatible with the terrain and never exceed 16 km/h, as this reduces maintenance and consequently increases the life of the CRSG.
- ⚠ Alcoholic beverage or some medications may cause loss of reflexes and change the operator's physical conditions. Therefore, never operate this CRSG under the influence of these substances.
- ⚠ Read or explain all the procedures of this manual to the operator who cannot read.

In case of doubts, refer to Post-Sales.

Telephone: 0800-152577 / E-mail: posvenda@baldan.com.br

▪ Components**• CRSG - Trailed Offset Disc Harrow**

- | | |
|----------------------------------|------------------------------------|
| 1. Pillar | 9. Articulation shaft hub |
| 2. Front frame | 10. Tire articulation shaft |
| 3. Rear frame | 11. Tires |
| 4. Coupling head | 12. Discs |
| 5. Hose support | 13. Bearing |
| 6. Stabilizer bar support | 14. Hydraulic cylinder |
| 7. Stabilizer rod | 15. Hydraulic hoses |
| 8. Stabilizer bar | 16. Wrenches |

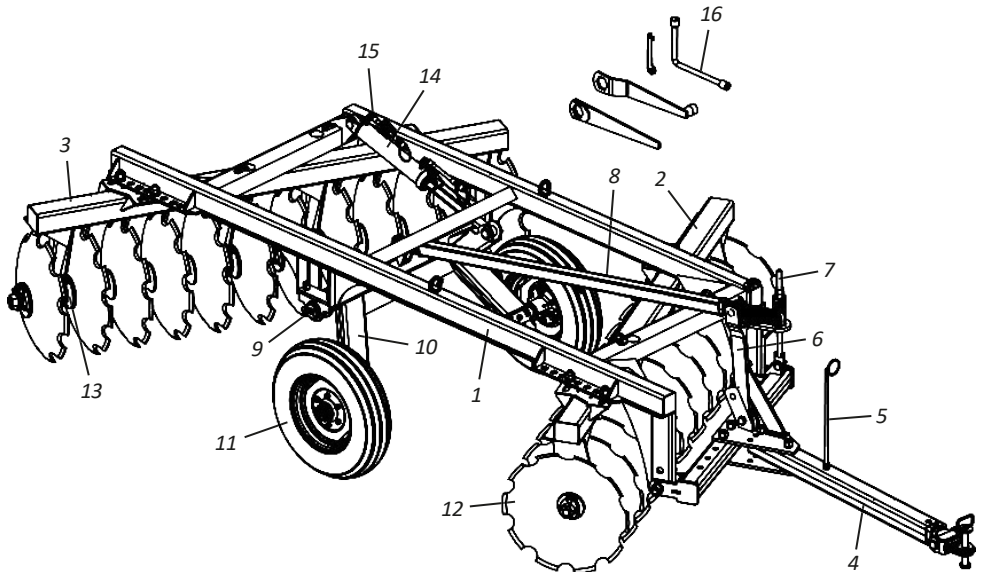

▪ Dimensions

• CRSG - Trailed Offset Disc Harrow

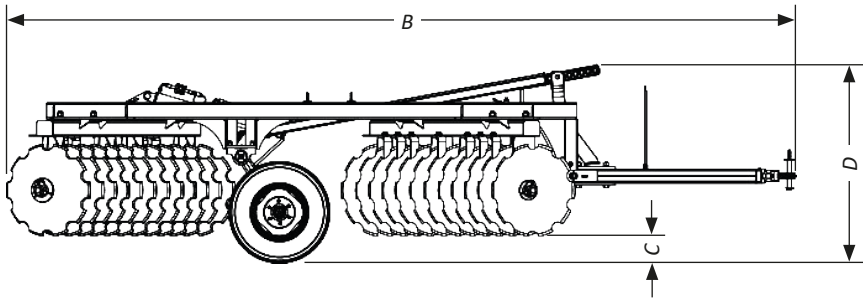
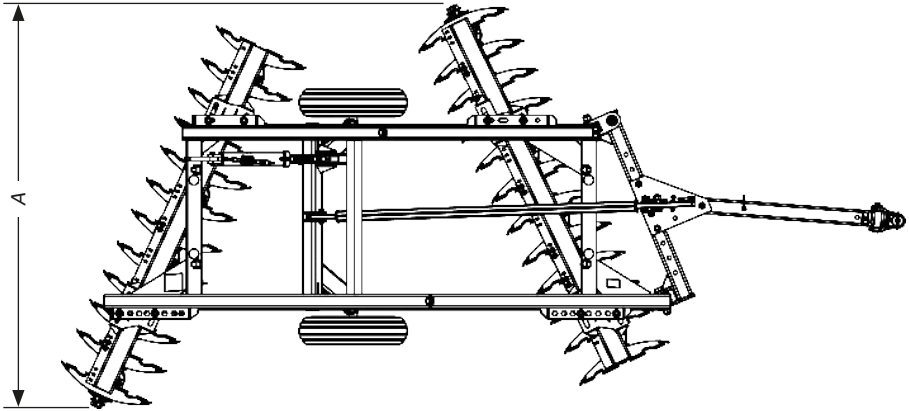

Model	Nr of Discs	Measure A (mm)	Measure B (mm)	Measure C (mm)	Measure D (mm)
CRSG	12	1583	5260	173	1439
CRSG	14	1793	5303	173	1439
CRSG	16	2013	5348	173	1439
CRSG	18	2224	5919	260	1512
CRSG	20	2449	5941	260	1512
CRSG	22	2663	6002	260	1512
CRSG	24	2897	6057	260	1512
CRSG	28	3312	6150	260	1512

▪ Specifications

• CRSG - Trailed Offset Disc Harrow

Model	Nr of Discs	Working Width (mm)	Disc Diameter (ø)	Approximate Weight (Kg)			Tractor Power (HP)	Tires
				24"	26"	28"		
CRSG	12	1300	24" - 26" - 28"	1299	1341	1377	63 à 70	600x16
	14	1550	24" - 26" - 28"	1354	1403	1445	74 à 80	600x16
	16	1750	24" - 26" - 28"	1430	1486	1534	85 à 95	600x16
	18	2000	24" - 26" - 28"	1827	1890	1944	95 à 105	750x16
	20	2250	24" - 26" - 28"	1955	2025	2085	106 à 118	750x16
	22	2420	24" - 26" - 28"	2027	2104	2170	132 à 145	750x16
	24	2700	24" - 26" - 28"	2099	2183	2255	148 à 163	750x16
	28	3200	24" - 26" - 28"	2268	2366	2450	169 à 185	750x16

Axle diameter (ø) 1.5/8"
 Disc spacing 235 mm
 Working depth 150 - 250 mm

*Baldan reserves the right to change and/or perfect the technical characteristics of its products, without previous notice, and without obligation to proceed in the same way with the products previously manufactured.
 Technical specifications are approximate and informed under normal work conditions.*

INTENDED USE OF THE CRSG





- The **CRSG** was developed for soil preparation work for cereal planting and pasture renewal.
- The **CRSG** must be conducted and operated only by a properly instructed operator.

UNAUTHORIZED USE OF THE CRSG

- To avoid damage, serious accident or death, do not transport people over any part of the **CRSG**.
- Using the **CRSG** to hitch, tow or push other implements or accessories is not allowed.
- The **CRSG** must not be used by an inexperienced operator who is not familiar with all driving, command and operation techniques.

▪ Assembly

The **CRSG** leaves the factory disassembled. To assembly it, follow the instructions below:

-  The **CRSG** must be assembled by the resale, through trained and qualified personnel for this work.
-  Before assembling the **CRSG**, look for an ideal location where you can easily identify its parts and assembly.
-  Do not wear loose clothing, as they may get caught into the **CRSG**.
-  Use PPE (Safety Equipment).

• Wrench set

When assembling, disassembling, or servicing the **CRSG**, use the set of wrenches provided with the harrow. The Wrench Set consists of:

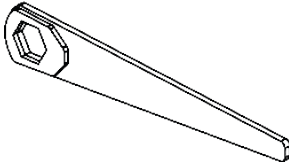

WRENCH FOR 1.5/8" HEX NUT

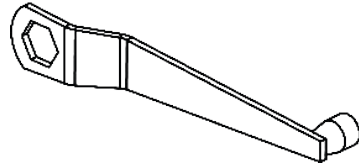

WRENCH FOR 1.5/8" AND 1" HEX NUT

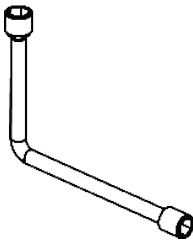

WRENCH FOR 5/8" AND 3/4" HEX NUT

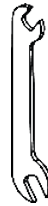

WRENCH FOR 3/8" AND 1/2" HEX NUT

 **ATTENTION** | If any wrench is lost or broken, get another one immediately. Always use original Baldan wrenches.

▪ Assembly

• Assembling discs section

When starting the **CRSG** assembly, always start with the disc set, proceeding as follows:

- 01** - Fit the locking washer (2), flat washer (3), locking nut (4), nut (5) onto the shaft (1), securing it with the lock washer (6) and bolt (7).
- 02** - Then, place, onto the shaft (1), disc (8), bearing (9), another disc (8), separator spool (10) and so on.
- 03** - When the assembly is complete with all discs, bearings, separator spools, place the convex thrust washer (11), plain washer (12), lock (13), nut (14), tightening with a wrench until the whole set is secured.
- 04** - Then, fit the disc assembly and tighten the nut (14) by impacts. When you are about to reach maximum torque, adjust the lock (13) with the convex washer (11), always tightening the nut until coincide with the boring, attach it with the pressure washer (15) and screw (16).

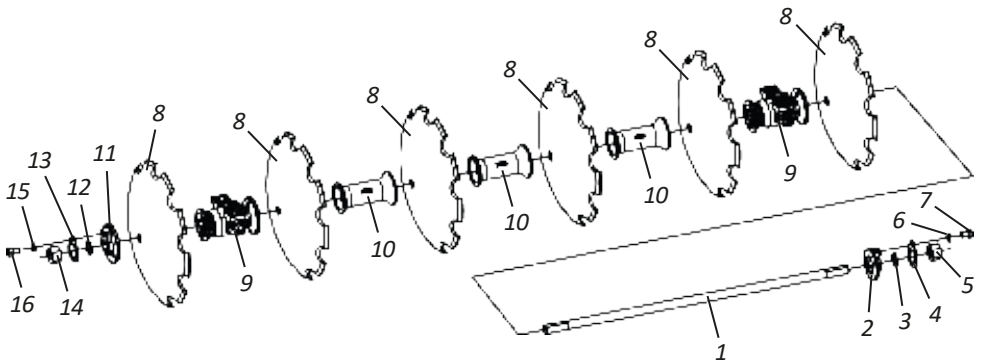

! ATTENTION

During the first week of use of the **CRSG**, retighten all bolts and nuts on the disc sections daily, then retighten them periodically.

! IMPORTANT

Check the right side of the separating spools and bearings according to the concavity of the discs.

▪ Assembly

• Assembling disc sections - Part I

Check the assemblies of disc sections of the **CRSG 12, 14 and 16** discs below.

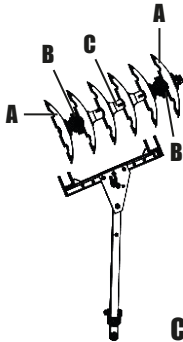
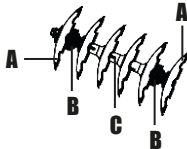

CRSG 12 DISCS

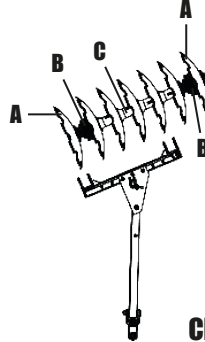
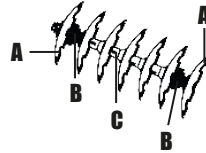

CRSG 14 DISCS

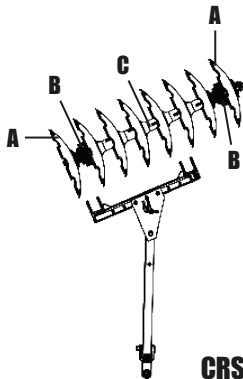
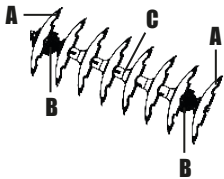

CRSG 16 DISCS

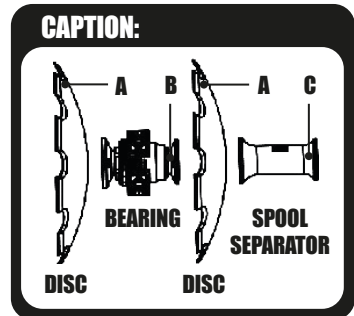

▪ **Assembly**

• **Assembling disc sections - Part II**

Check the assemblies of disc sections of the **CRSG 18, 20 and 22** discs below.

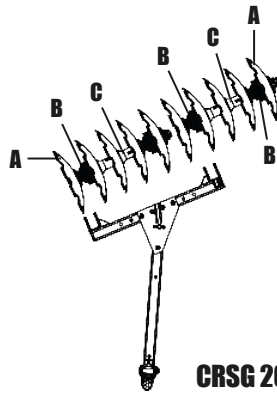
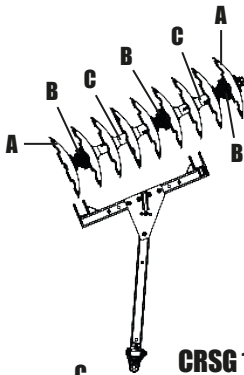
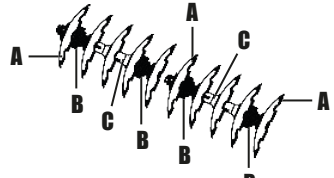
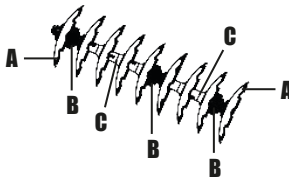

CRSG 18 DISCS

CRSG 20 DISCS

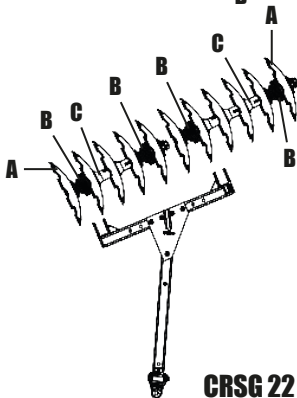
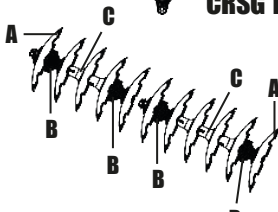

CRSG 22 DISCS

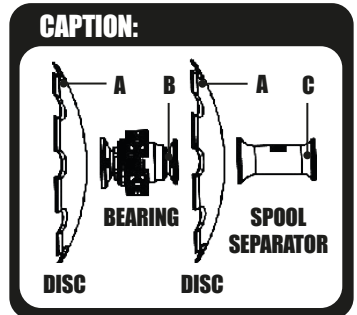

▪ Assembly

• Assembling disc sections - Part III

Check the assemblies of disc sections of the **CRSG 24** and **28** discs below.

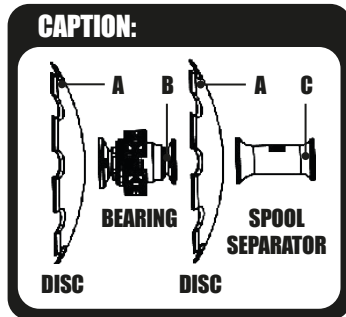
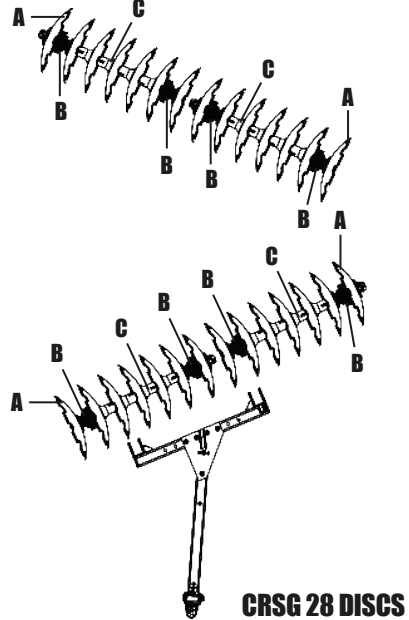
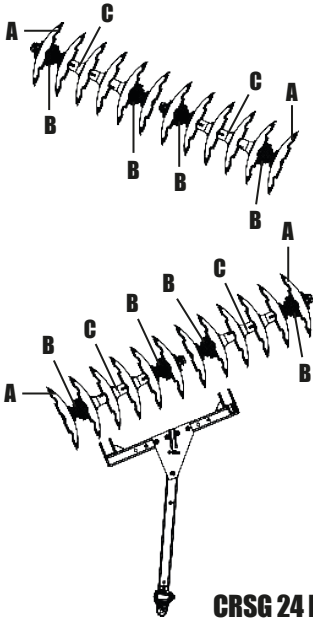

▪ Assembly

• Assembly the frames into the upright

To attach the front and rear frames to the upright, proceed as follows:

- 01** - Place the front (1) and rear (2) frames in a clean and flat place.
- 02** - Then install the upright (3) on the front (1) and rear (2) frames by fastening them through the bolts (4), locking lugs (5), plain washers (6), locking washers (7) and nuts (8).

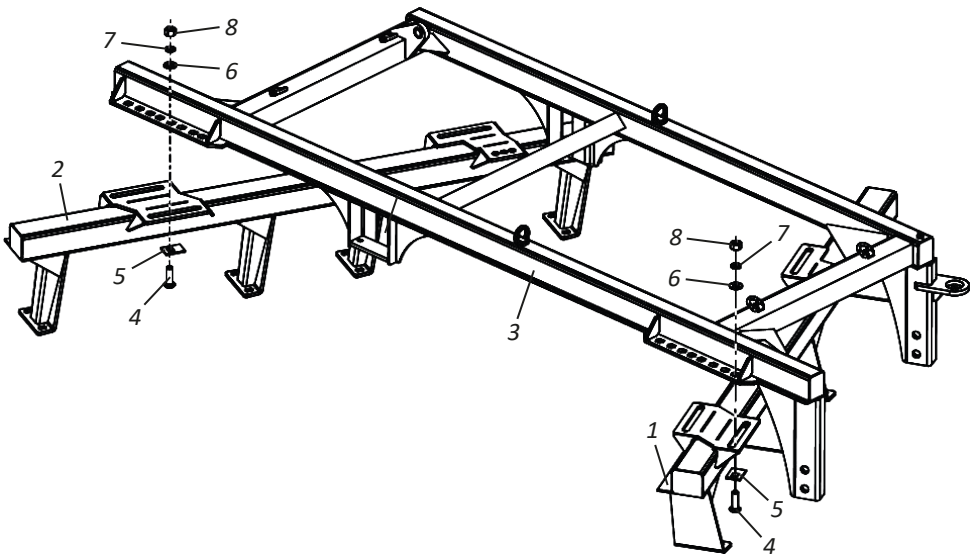

ATTENTION

To lift the upright (3), follow the instructions on page 55.
Ignoring this warning may cause severe accidents or death.

▪ Assembly

• Assembling disc sections on frames

After securing the front and rear frames to the upright, make the securing of disc sections to do this, proceed as follows:

- 01** - Lift the front or rear of the harrow and place the disc section (3) in line and match the drilling of the slabs (4) with the bearings and secure them with screws (5), plain washers (6) and nuts and locknuts (7).
- 02** - Then, lift the other part of the harrow and repeat the operation by checking the concavity of the discs from one section to the other that should be opposite.
- 03** - When finishing the assembly, check that the slabs (4) are facing the concavity of the discs.

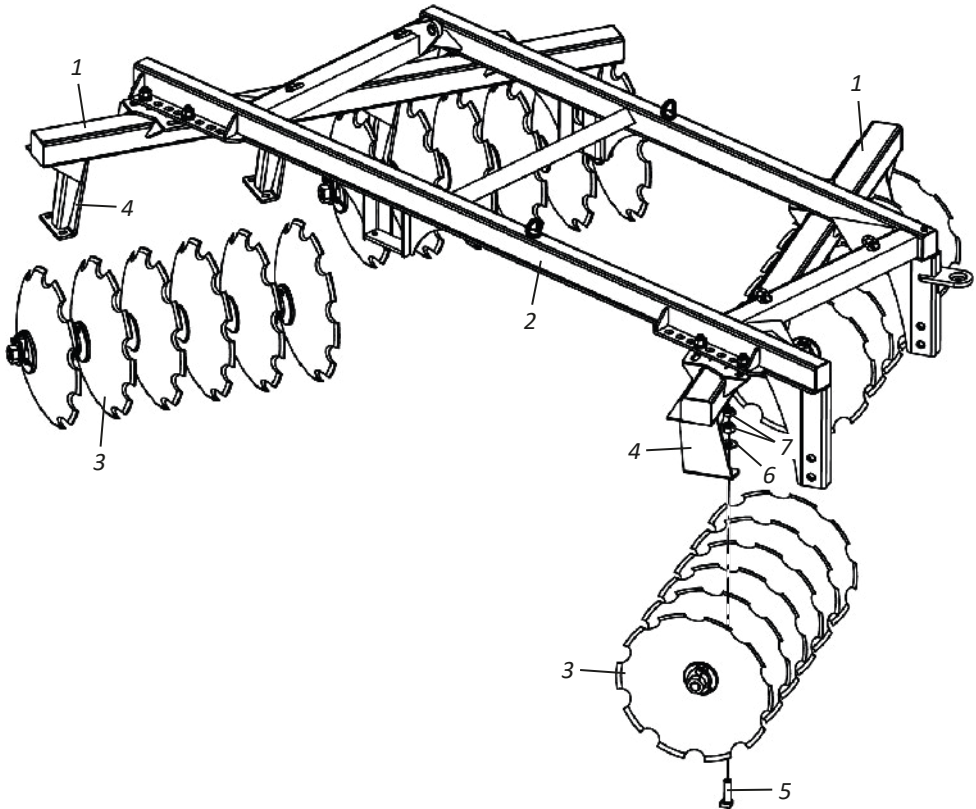

ATTENTION

When assembling the disc sections on the frames, note that the frame slabs should face the discs' concavity.

▪ Assembly

• Assembling the wipers

After assembling the disc sections on the frames, secure the wipers, proceeding as follows:

- 01** - Fit the wiper blades (1) into the frames (2), using washers (3), plain washers (4), lock washers (5) and nuts (6).

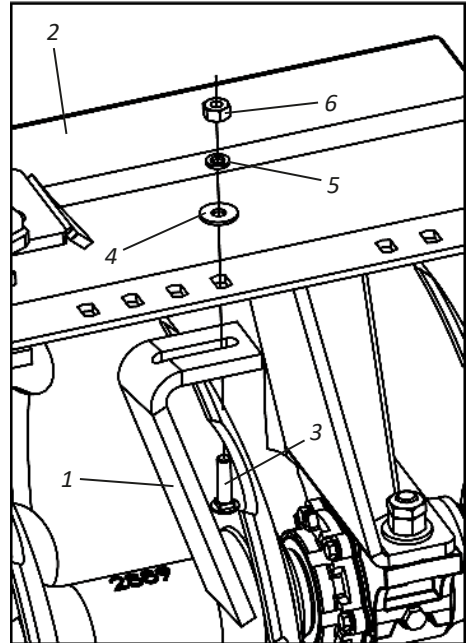

MAXIMUM ASSEMBLY CONDITION:

Centralized wiper between discs

MINIMUM ASSEMBLY CONDITION:

Wiper closest to disc

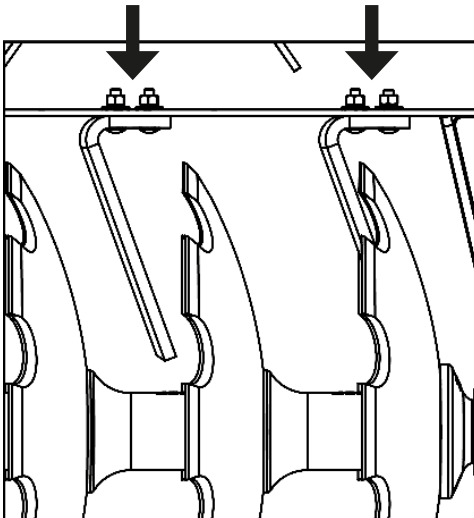

ATTENTION

The wipers (1) allow adjustment to bring them closer or further away from the discs. When assembling the wipers (1), position them in a way that best meets your needs according to the soil condition.

▪ Assembly

• Assembly the wheel shaft support

After assembling the wipers, secure the wheel shaft support, proceeding as follows:

- 01** - Attach the hubs (1) to the wheel hub (2), then secure the hubs (1) to the upright (3) through bolts (4), locking washers (5), nuts and locknuts (6).

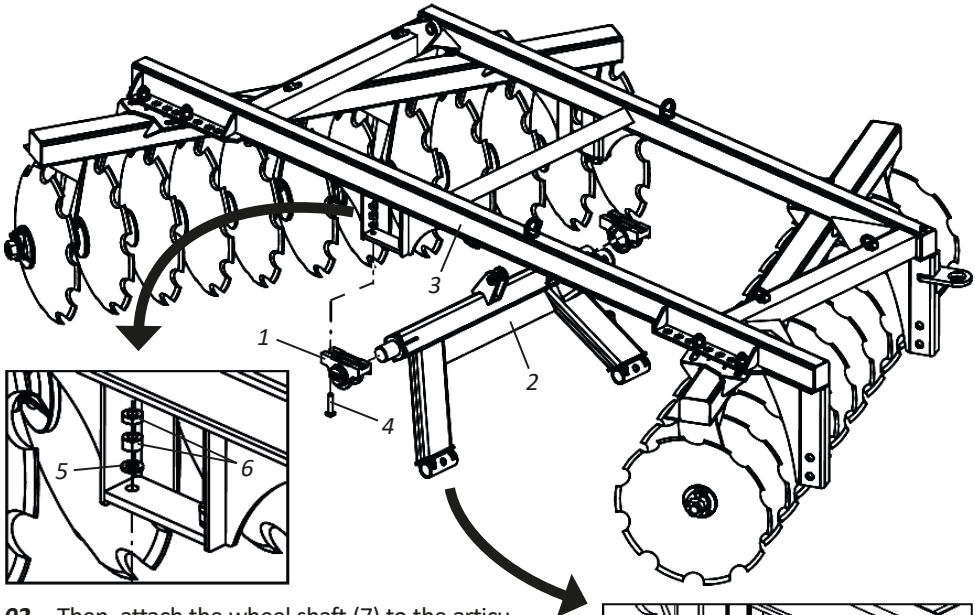

- 02** - Then, attach the wheel shaft (7) to the articulation shaft of the wheel (2) with bushing (8), bolt (9) and nut (10).

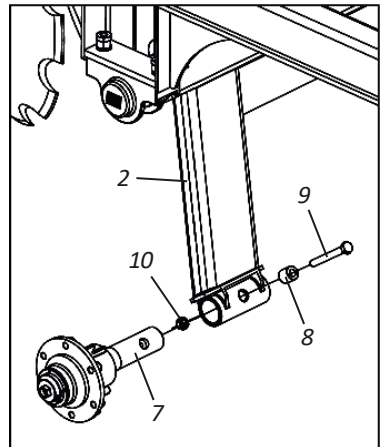

▪ Assembly**• Tire assembly**

After assembling the wheel shaft support, secure the tires, proceeding as follows:

01 - Attach the tires (1) to the wheel shaft (2) through the bolts (3) and nuts (4).

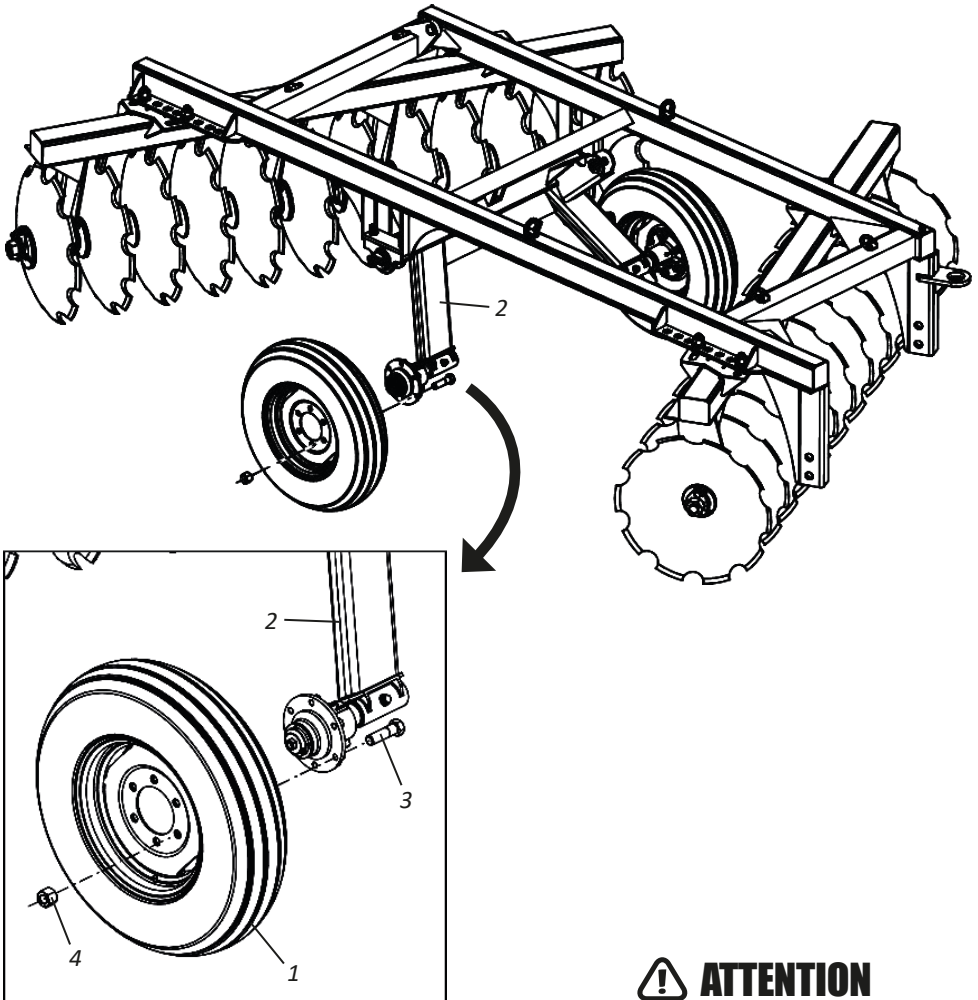
**⚠ ATTENTION**

Check the correct calibration of tires on page 47.

▪ Assembly

• Assembling hydraulic cylinder

After fitting the tires, fix the hydraulic cylinder for this, proceed as follows:

- 01** - Attach the base of the hydraulic cylinder (1) to the upright (2) through the pin (3) and cotter pin (4).
- 02** - Then, attach the hydraulic cylinder rod (1) to the wheel shaft holder (5) through the pin (6), flat washer (7) and cotter pin (8).

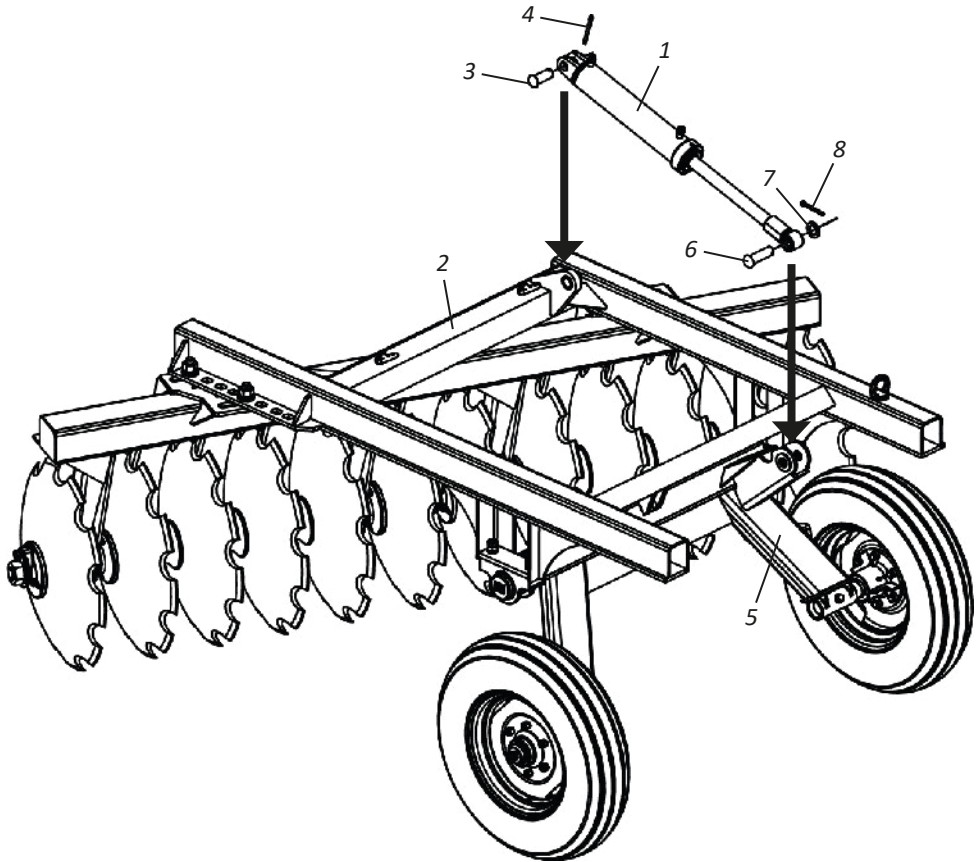

ATTENTION

When assembling the hydraulic cylinder, it must be positioned upwards.

▪ Assembly

• Assembling coupling head

After assembling the hydraulic cylinder, secure the coupling head, proceeding as follows:

- 01** - Insert the rod (1) into the upright (2).
- 02** - Then attach the coupling crossbar (3) to the upright (2) and between both, fit wear washers (4), securing the set with bolts (5), pressure washers (6) and nuts (7).
- 03** - Then secure the rod (1) to the crossbar (3) through pin (8) flat washer (9), cotter pin (10) and fit stop bushing (11), spring (12), stop bushing (13), nut and lock nut (14).
- 04** - Finish by attaching the stabilizer bar bracket (15) to the coupling head (16) through bolt (17), washer (18) and nut (19).

! IMPORTANT

When checking friction between the upright (2) and the crossbar (3), immediately replace wear washers (4).

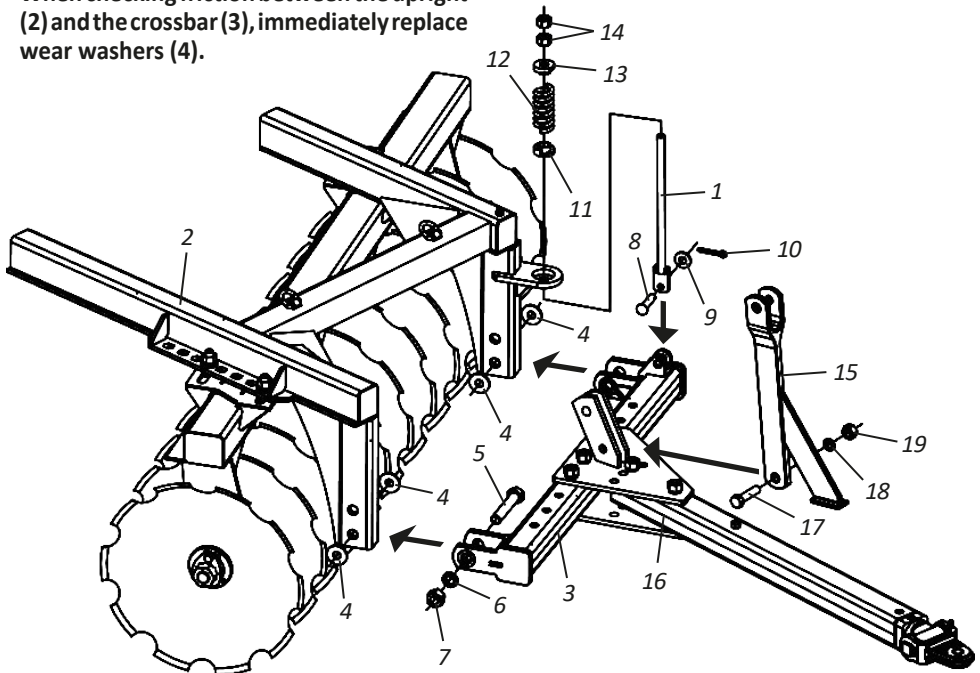

! ATTENTION

Always install washers (3) between two washers (2) when assembling the crossbar (4) onto the upright (2), as these washers prevent friction between the upright (2) and the crossbar (3).

▪ Assembly

• Assembling stabilizer bar

After assembling the coupling header, attach the stabilizer bar, proceeding as follows:

- 01** - Attach the base of the stabilizer bar (1) to the articulation shaft of the wheel (2) through the pin (3), flat washer (4) and cotter pin (5).
- 02** - Then, attach the front stabilizer bar (1) to the stabilizer bar bracket (6) through the pin (7), flat washer (8) and lock (9).

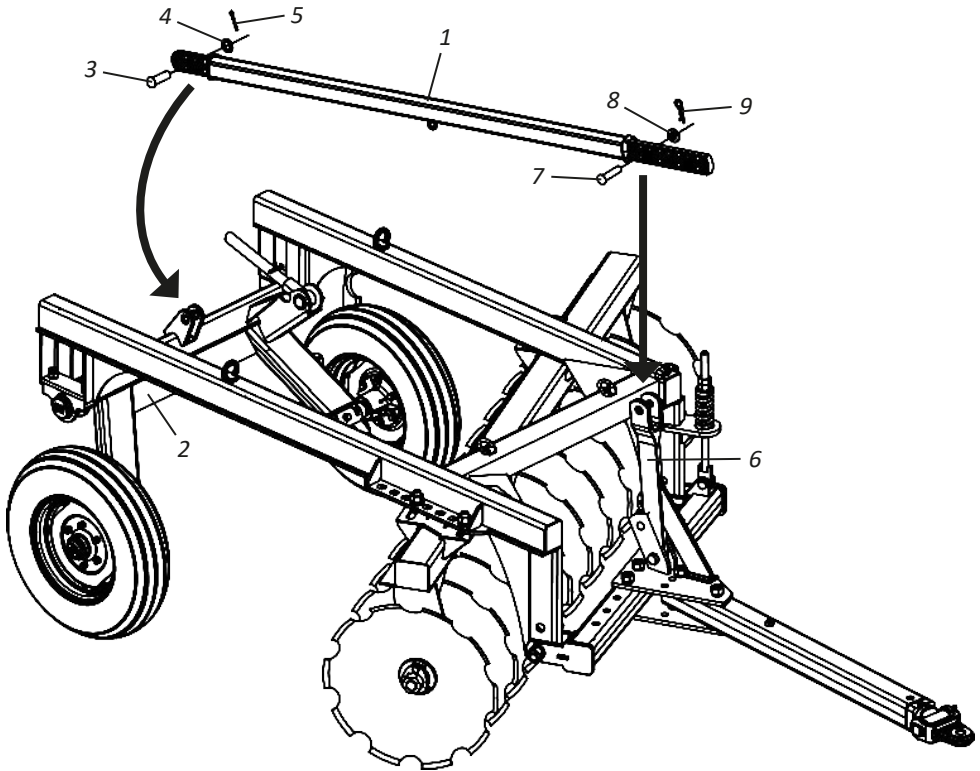

▪ Assembly

• Assembly hydraulic hoses

After assembling the stabilizer bar, attach the hydraulic hoses to this, proceed as follows:

- 01** - Attach the hose support (1) to the coupling head (2) through the lock nuts (3).
- 02** - Then, attach the hydraulic hoses (4) to the hydraulic cylinder (5).
- 03** - Then secure the hydraulic hoses (4) on the upright (6) through the clamp (7), washer (8) and bolt (9).

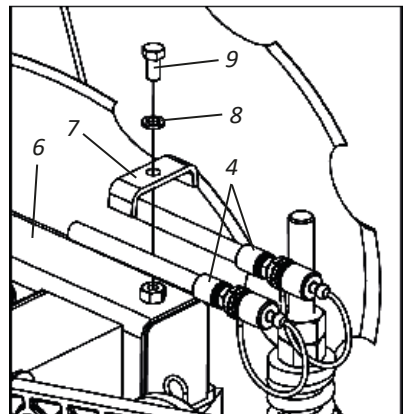
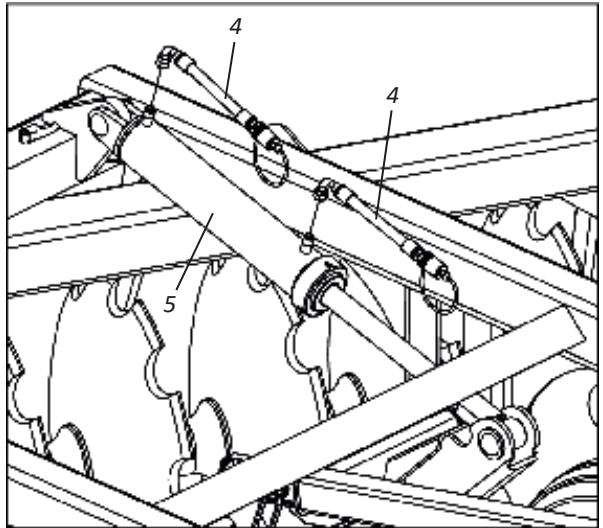
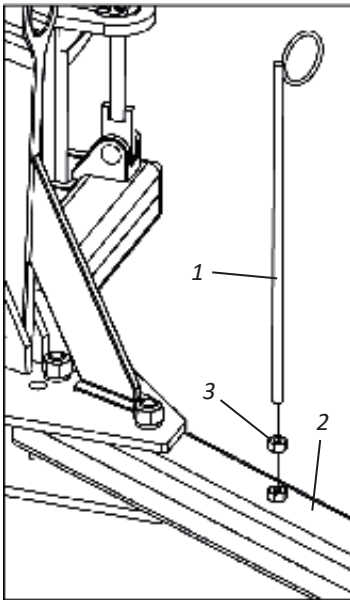

! ATTENTION

When assembling the hydraulic hoses, do not let terminals touch the ground.

! IMPORTANT

Always use "thread seal" to engage "male" quick couplings onto the hoses.

▪ Hitch

• Harrow coupling in the traction bar of the tractor

To couple the **CRSG**, proceed as follows:

- 01** - Slowly approach the tractor in the reverse gear, paying attention to the application of the brakes. Then, turn off the tractor engine, relieve the pressure of the control by pushing the lever a few times and check that the couplings are clean if you are not cleaning them.
- 02** - Then start the engine by lowering the **CRSG** tires until the pin (1), flat washer (2) and lock (3) are in the "A" hole.
- 03** - Then start the engine by lifting the **CRSG** tire until the shackle (4) is at the height of the tractor bar.
- 04** - Then engage the **CRSG** to the tractor by attaching the locking pin (5), plain washer (6) and ring lock (7).
- 05** - Finish by attaching the hydraulic hoses (8) to the tractor quick coupling.

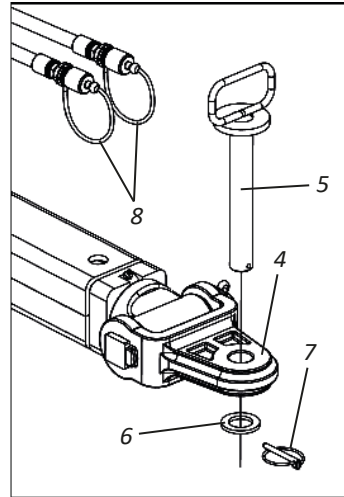
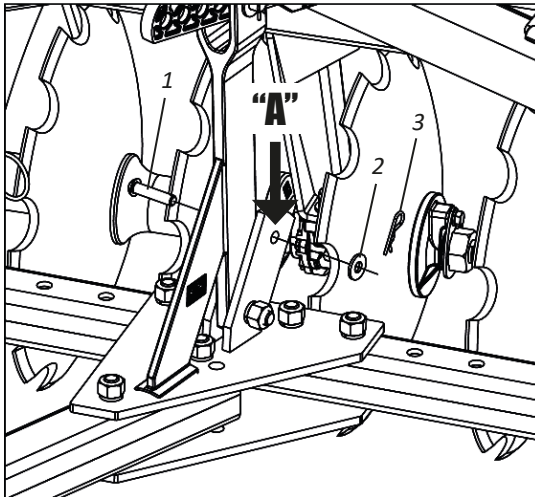

ATTENTION

After engaging the **CRSG** to the tractor, **REMOVE** pin (1) from hole "A". Do not transport or work the harrow without first removing the pin (1) from the header. Ignoring this warning may damage the **CRSG**. For easy removal of the pin (1), operate the tire lowering control.

IMPORTANT

Never disengage the hydraulic hoses without first lowering the **CRSG** and relieving the control pressure.

OBSERVATION

When engaging the **CRSG**, look for a safe and easily accessible place. Always use low gear with low acceleration.

▪ Levelling

• Levelling of the harrow - Part I

To level the **CRSG**, proceed as follows:

- 01** - Place the tractor and **CRSG** in a flat location.
- 02** - Then raise the lift to the railing and see if the **CRSG** is positioned in the front or rear position.

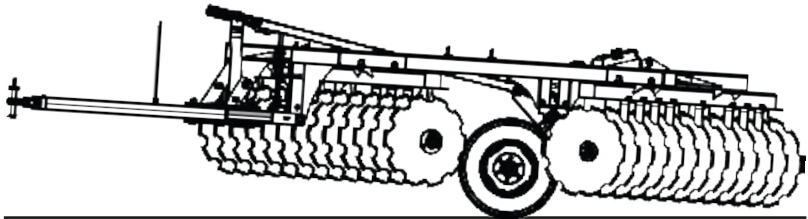

CRSG POSITIONED IN THE REAR

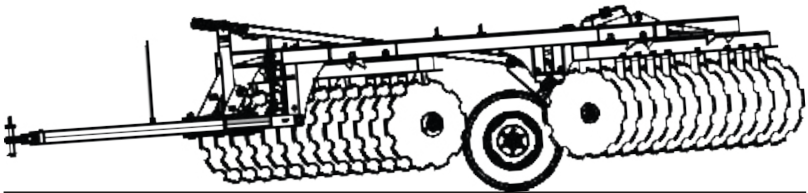

CRSG POSITIONED ON THE FRONT

If the **CRSG** is positioned in the front or rear, proceed as follows:

- 01** - Lower the **CRSG** until it is completely on the ground.
- 02** - Then, loosen the lock (1), flat washer (2) and remove the pin (3).
- 03** - Then adjust another point on the stabilizer bar (4) and secure it again.
- 04** - Lift the **CRSG** and check that the harrow is level as shown on the following page.

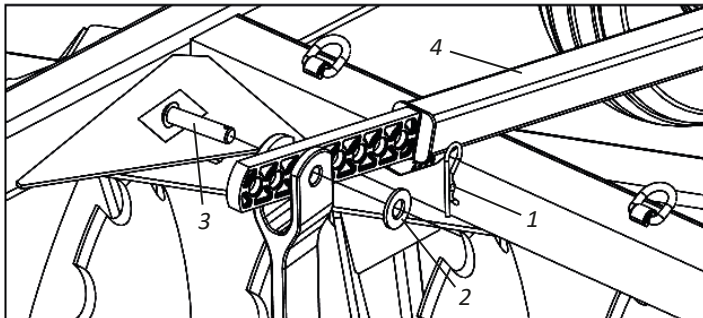

▪ Levelling

• Levelling of the harrow - Part II

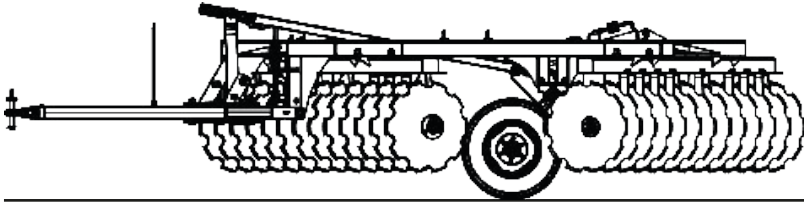

CRI LEVEL POSITION

05 - If the **CRSG** is not level, repeat the previous procedures by setting another point on the stabilizer bar (4).

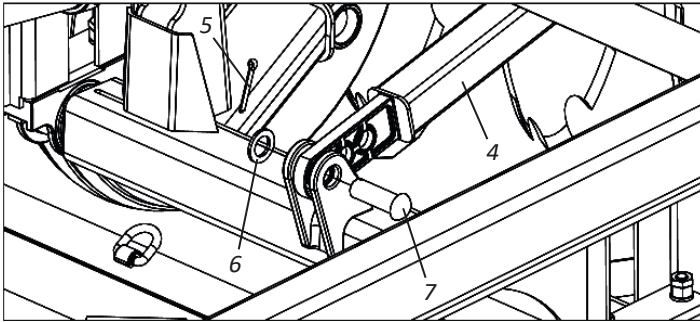

! ATTENTION | If necessary, loosen the cotter pin (5), flat washer (6) and pin (7), adjust another point on the base of the stabilizer bar (4) and secure it again.

▪ Adjustments

• Regulation for transport

Before transporting **CRSG**, proceed as follows:

- 01** - Fully actuate the stroke of the hydraulic cylinder (1) of the wheel (2).
- 02** - Then install the lock (3) by attaching it to the pins (4) and locks (5).

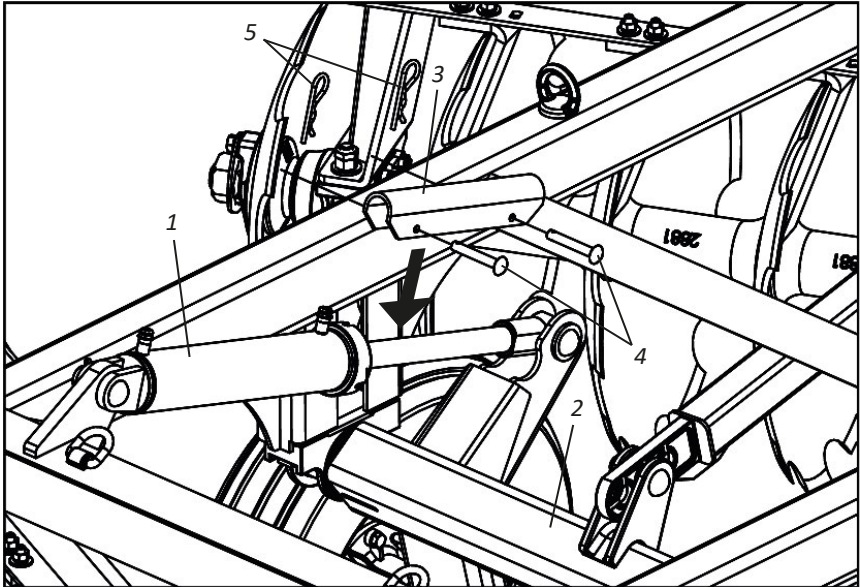

ATTENTION

Do not carry the **CRSG** without fitting the lock (3) on the hydraulic cylinder (1) of the wheel (2). Ignoring this warning may cause damage to the hydraulic cylinder (1).



IMPORTANT

After transporting the **CRSG**, remove the lock (3) from the hydraulic cylinder (1), releasing the locks (5) and the pins (4).

▪ Adjustments

• Harrow opening adjustment

To obtain an ideal penetration of discs, the opening of the harrow must be adjusted, which varies according to the type of soil:

- **GROUNDS OF GREATER PENETRATION DIFFICULTY:** The harrow opening should be increased.
- **LIGHT AND LOOSE GROUNDS:** The harrow opening should be reduced.

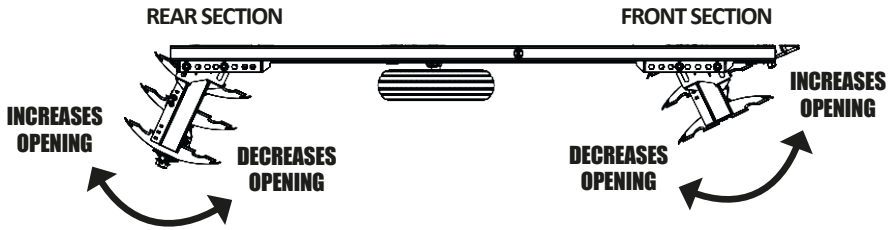

INCREASES OPENING: Higher Depth.

DECREASES OPENING: Lower Depth.

To increase or decrease the harrow opening, proceed as follows:

- 01 - Unscrew the nuts (1), locking washers (2), plain washers (3), remove locks (4) and bolts (5).
- 02 - Then adjust the frames (6) by decreasing or increasing their opening.
- 03 - Then, fasten the frame (6) to the upright (7) by means of the bolts (5), locks (4) plain washers (3), spring washers (2) and nuts (1).

❗ IMPORTANT

To start the job, we recommend using a medium opening in the disc sections. If you need more penetration, increase the opening angle of the rear section. The front section generally does not operate with an opening larger than the rear section. Wheels also assist in depth control of the discs.

🔍 OBSERVATION

We advise you to control the depth of CRSG work by opening the disc sections and using the tires only in places where CRSG penetrates too much.

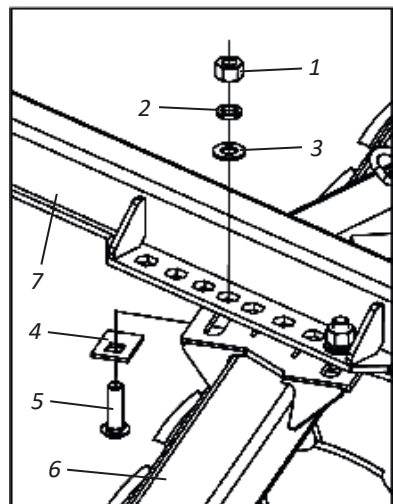

▪ Adjustments

• Working depth adjustment

In order to adjust the working depth through tires, limiting rings (1) are placed on the shafts of the hydraulic cylinders (2), providing many adjustments of working depth. To adjust the working depth, proceed as follows:

- 01 - Remove limiting rings (1) from hydraulic hoses (2).
- 02 - Then, tighten the rods of the hydraulic cylinders (3) of the wheel until necessary.
- 03 - Then fit the limiting rings (1) on the rods of the hydraulic cylinders (3) to fill the entire space between the rod coupling and the hydraulic cylinder plunger (3).
- 04 - After finishing work with the **CRSG**, remove limiting rings (1), hydraulic cylinders (3) from the wheel support and place it in the hydraulic hoses (2).

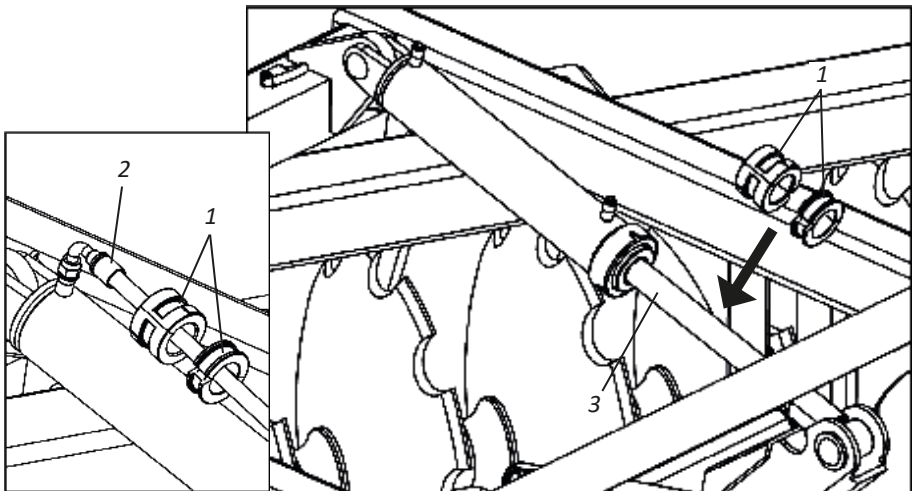

! IMPORTANT

After adjustment, the **CRSG** will always operate at the same depth, both in hard and loose terrain, because the limiting rings (1) are limiting the stroke of the hydraulic cylinder (3) of the wheel, that is, preventing the wheels from oscillating.

🔍 OBSERVATION

Limiting rings (1) accompanying the **CRSG** have different sizes which combined offer various depth settings.

▪ Adjustments

• Harrow displacement adjustment - Part I

The displacement of the **CRSG** must be done when the harrow is not giving a perfect finish, that is, leaving traces of the tractor. For the harrow to work centrally with the tractor's drawing line, proceed as follows:

- 01** - Remove cotter pins (1), loosen castle nuts (2), plain washers (3) and remove the bolt (4).
- 02** - Then move the coupling head (5) on the crossbar (6), making an adequate adjustment.
- 03** - Finish by tightening bolts (4), plain washers (3), castle nuts (2) and cotter pins (1).

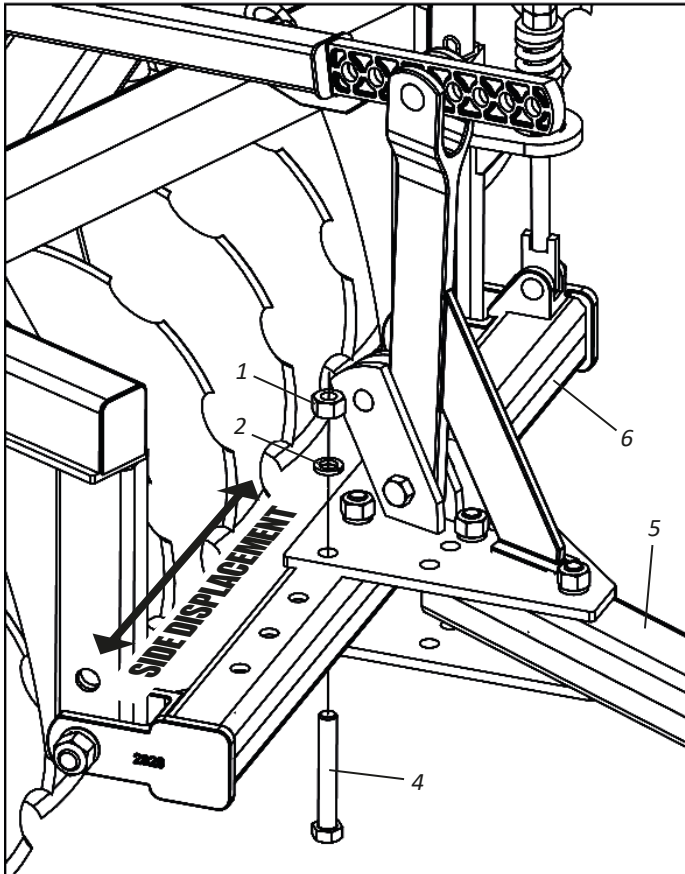

▪ Adjustments

• Harrow displacement adjustment - Part II

Under normal working conditions and during transport, the coupling head (5) must remain in the center hole of the upper (7) and lower (8) plates. By changing the coupling head (5) to the other holes "A", "B" and "C", small lateral displacements of the **CRSG** are obtained.

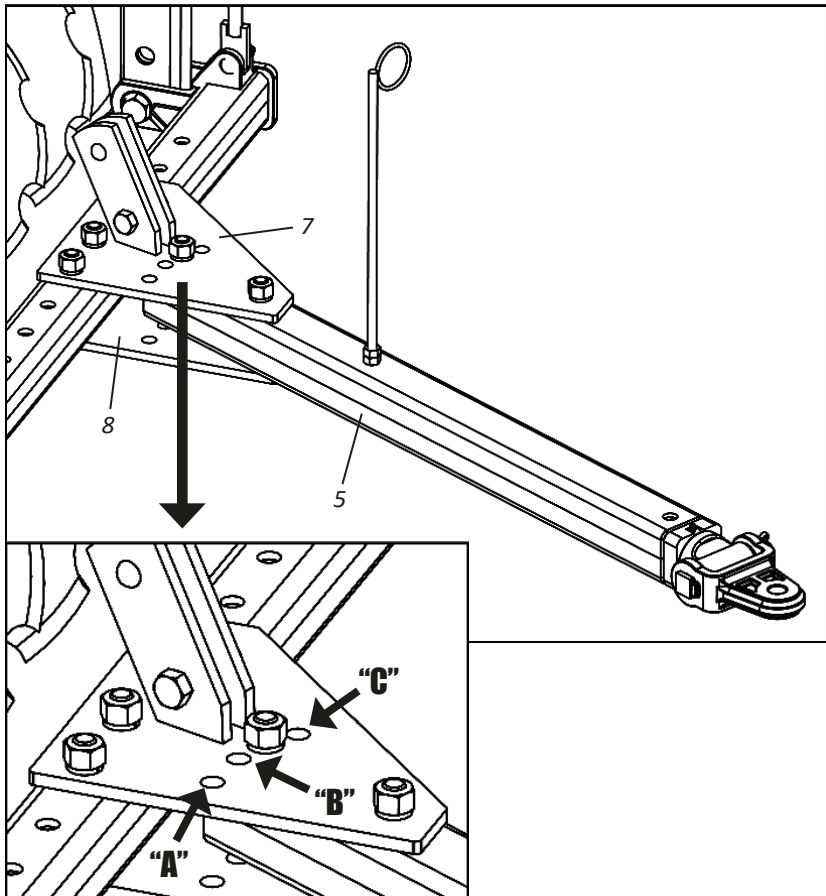

! IMPORTANT

The **CRSG** head and the tractor drawbar must be as close to the working direction as possible.

The tractor drawbar must remain loose during work and fixed during transport.

▪ Operations

• Operating recommendations - Part I

The preparation of the **CRSG** and the tractor will allow you to save time in addition to obtain better result in the field work. The following suggestions may be useful for you.

HARROW STRUCTURE

After the first day of working with the **CRSG**, tighten all bolts, nuts and check the condition of the bolts and latches of the harrow structure. Then perform a general re-tightening on all screws and nuts in the harrow structure every 24 hours of work.

DISCS SECTIONS

Pay particular attention to the disc sections of the **CRSG**. During the first week of use of the **CRSG**, retighten all bolts and nuts on the disc sections daily, then retighten them periodically.

GENERAL RECOMMENDATION

- 01** - Adjust the tractor according to the content of the instruction manual, always using front and rear weights to stabilize the equipment.
- 02** - Always couple to the tractor in low gear and very carefully.
- 03** - When using the **CRSG**, it is important to check the hitch and transverse leveling system to make sure that the discs will have the same penetration depth into the ground.
- 04** - After the hitching and leveling, the next adjustments will be made directly in the field of work, analyzing the terrain in its texture, humidity and the types of operations to be done with the **CRSG**.
- 05** - On the tractor, choose a gear that allows to maintain a certain power reserve, guaranteeing against unforeseen efforts.
- 06** - Observe the working and transport speeds specified on page 10. We do not advise you to exceed the speeds to maintain service efficiency and avoid possible damage to the **CRSG**.
- 07** - When executing maneuvers in the headwheels, first actuate the hydraulic cylinders gradually, lifting the disc sections.
- 08** - Do not uncouple any hose without first relieving the circuit pressure by turning the control levers a couple of times with the engine off.

▪ Operations

• Recommendations for operation - Part II

- 09 - Remove pieces of wood or any other object that may be attached to the discs.
- 10 - In compacted areas where the penetration of the discs is difficult, depth can be minimal, making work unsatisfactory. In these cases, applying other more suitable products is recommended.
- 11 - During work or transport, the tractor's drawbar must remain fixed.
- 12 - When performing any maintenance on the **CRSG**, lower it to the ground and switch off the engine.
- 13 - The **CRSG** has several settings, but only local conditions can determine the best setting.

If in doubt, never operate or handle the **CRSG**, see Post Sale.
Telephone: 0800-152577 / E-mail: posvenda@baldan.com.br

• Direction of maneuvers

During harrowing (with the discs on the ground), **DO NOT** maneuver to the right, as the angles formed by the disc sections will transmit great effort to the equipment, especially the traction components.

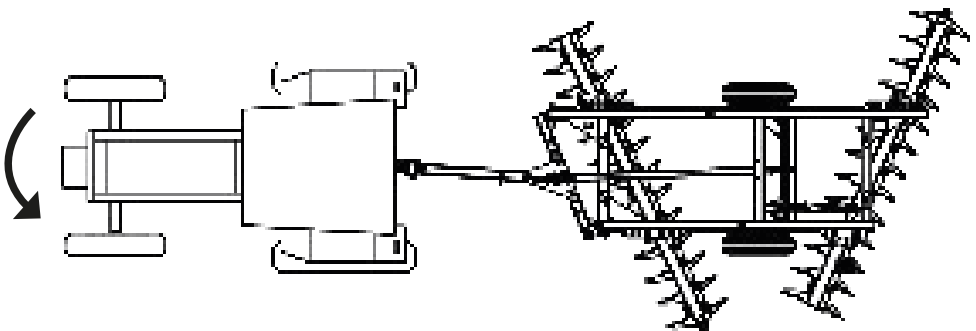

ATTENTION

With the disc sections in the ground, it is necessary to make maneuvers to the left (closed side of the **CRSG**) avoiding overloads.

▀ Operations

• How to start harrowing

To start harrowing, always follow terraces or contour line, so that the terrace is always on the left side of the tractor.

OBSERVATION

Before starting operations with the CRSG, thoroughly inspect it by tightening all bolts, nuts, hose terminals, shafts, and especially the disc sections.

• Harrow from the outside in

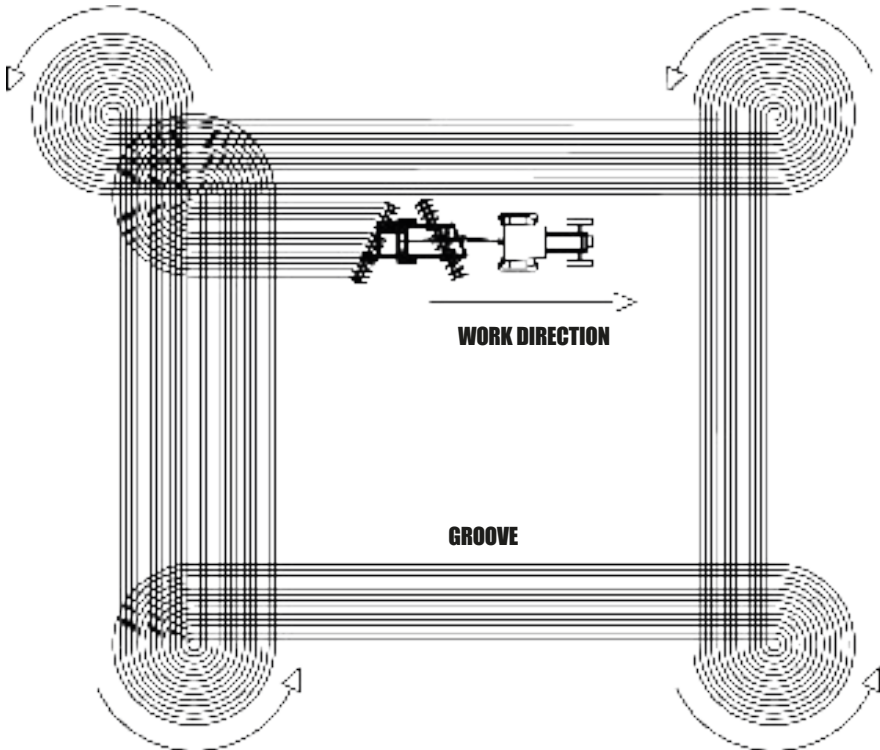

IMPORTANT

Try to drive the tractor for good performance between CRSG passes. Avoid forming non-harrowed tracks.

▀ Operations

• Harrow from the inside out

In this direction, greater perfection is obtained. When walking on headers too much, you may want to start another block.

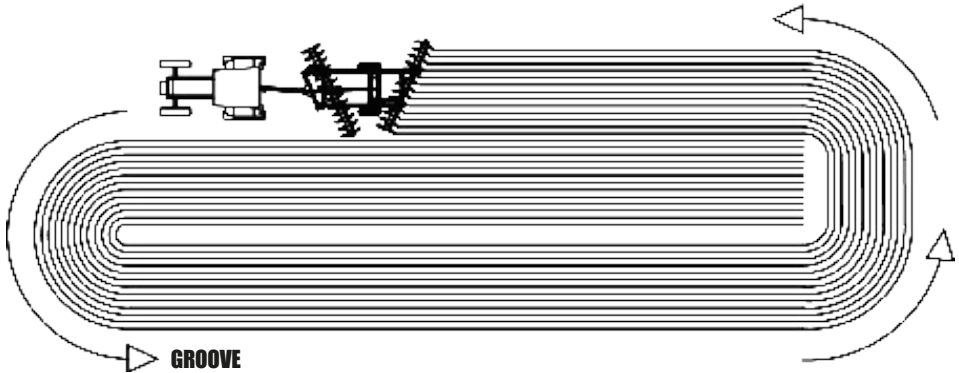

• Blocks with contour lines

For terrains with contour line, it is usual to start with two blocks at a time, starting the work with the contour line on the left side of the tractor. When you reach the middle of the contour line, you may want to start another block to reduce fuel consumption.

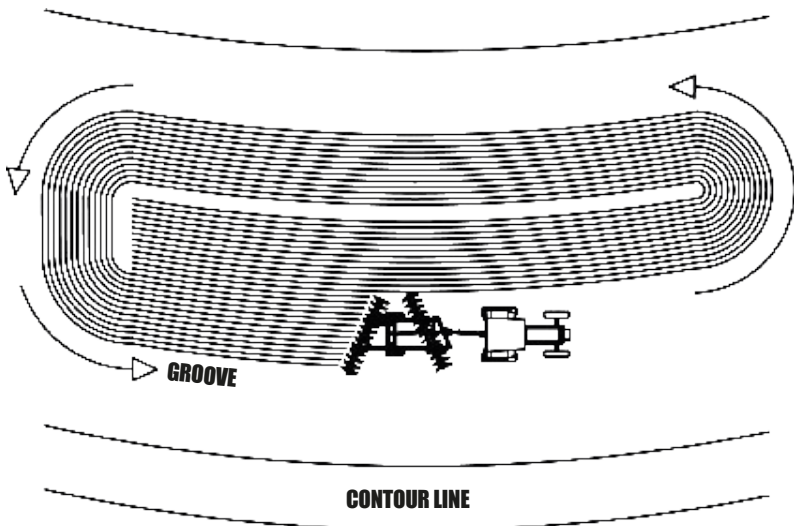

▪ Calculation

• Hourly production - Part I

To calculate the approximate hourly output of the **CRSG**, use the following formula:

$$A = \frac{L \times V \times F}{X}$$

WHERE:

A = Area to be worked

L = Working width of the harrow (in meters)

V = Average speed of the tractor (in meters/hour)

F = Production factor: 0.90

X = Value of the hectare: 10,000 m²

Example: A **CRSG 20 discos**, how much Ha will it produce in one hour of work at an average speed of 7 km/h.

A = ?

L = 6,23 m

V = 7.000 m/h

F = 0,90

X = 10.000 m² (Calculated in hectare)

$$A = \frac{2,25 \times 7.000 \times 0,90}{10.000} = 1,41 \text{ Ha/h}$$

Model	Nr of Discs	Working Width (mm)	Average Speed (m/h)	Production Factor	Approximate Production in Hectare Hour
CRSG	12	1300	7.000	0,90	0,81
	14	1550	7.000	0,90	0,97
	16	1750	7.000	0,90	1,10
	18	2000	7.000	0,90	1,26
	20	2250	7.000	0,90	1,41
	22	2420	7.000	0,90	1,52
	24	2700	7.000	0,90	1,70
	28	3200	7.000	0,90	2,01

▪ Calculation

• Hourly production - Part II

The formula for calculating approximate production refers to the calculation of areas to be worked or worked by the **CRSG**. If you want to know the time that will be spent to work in an area of known value, simply divide the value of this area by the hourly output of the **CRSG**.

Example: What time “X” will be spent for a **CRI 20 discs** harrow producing 35 hectares, at an average speed of 7km/h?

$$X = \frac{35 \text{ Ha}}{1,41 \text{ Ha/h}} = 24,82 \text{ horas aproximadamente p/ trabalhar 35 hectares.}$$



ATTENTION

A produção horária da CRSG pode variar por fatores que alteram o ritmo de trabalho como (umidade e dureza do solo, declividade do terreno, regulagens inadequadas e velocidade de trabalho).

▪ Maintenance

The **CRSG** has been developed to provide maximum performance over land conditions. Experience has shown that periodic maintenance of certain parts of the **CRSG** is the best way to help you avoid problems, so we suggest checks.

• Tires pressure

The tires should always be properly calibrated avoiding early wear due to excess or lack of pressure.

CRSG 12 TO 16 DISCS STANDARD

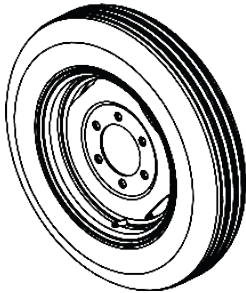

**TIRES 600 X 16 6 CANVAS
USE 44 LBS/POL²**

CRSG 18 TO 28 DISCS STANDARD

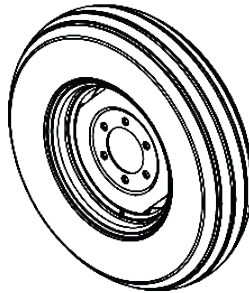

**TIRES 750 X 16 10 CANVAS
USE 60 LBS/POL²**

CRSG 12 TO 16 DISCS OPTIONAL

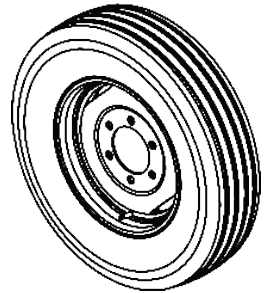

**TIRES 650 X 16 8 CANVAS
USE 54 LBS/POL²**

ATTENTION

Never weld the wheel mounted with tire, the heat may cause air pressure increase and provoke the explosion of the tire.

When filling the tire, position yourself besides the tire, never in front of it.

To fill the tire, always use containment device (armor cage).

Assemble the tires with proper equipment. The service should only be performed by people qualified for the work.

IMPORTANT

When calibrating tires, do not exceed the recommended calibration.

NOTE

The pressure of the tractor tires should be performed according to the manufacturer's recommendation.

CRSG 18 TO 28 DISCS OPTIONAL

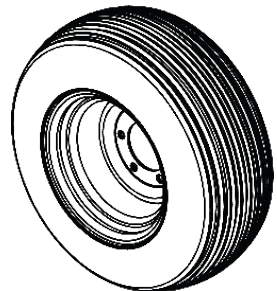

**TIRES 11 X 15 10 CANVAS
USE 44 LBS/POL²**

▪ **Maintenance**

The **CRSG** has been developed to provide maximum performance over land conditions. Experience has shown that periodic maintenance of certain parts of the **CRSG** is the best way to help you avoid problems, so we suggest verification.



ATTENTION

Check nuts and bolts constantly, if necessary, retighten them. General harrow retention maintenance should be done every 8 hours of work.

• **Lubrication**

Lubrication is indispensable for the good performance and durability of **CRSG's** moving parts, contributing to the maintenance cost savings.

Before starting the operation, carefully lubricate all grease cups, always observing the lubrication intervals in the following pages. Make sure of the lubricant quality regarding its efficiency and purity, avoiding products contaminated by water, dust and other agents.

• **Table of greases and equivalents**

Manufacturer	Types of grease recommended
Petrobrás	Lubrax GMA-2
Atlantic	Litholine MP 2
Ipiranga	Ipixflex 2
Castrol	LM 2
Mobil	Grease MP
Texaco	Marfak 2
Shell	Alvania EP 2
Esso	Multi H
Bardahl	Maxlub APG-2EP
Valvoline	Palladium MP-2
Petronas	Tutela Jota MP 2 EP
	Tutela Alfa 2K
	Tutela KP 2K



ATTENTION

If there are equivalent manufacturers and/or brands that are not listed in the table, consult the manufacturer's technical manual.

▪ Maintenance

- Lubrication every 24 hours of work

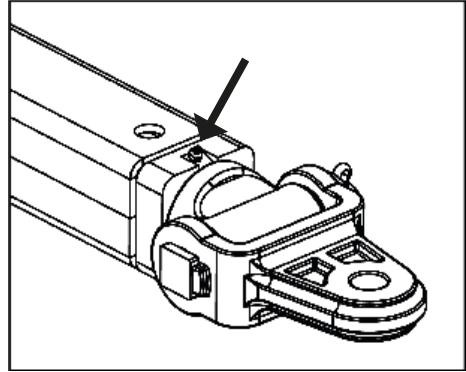
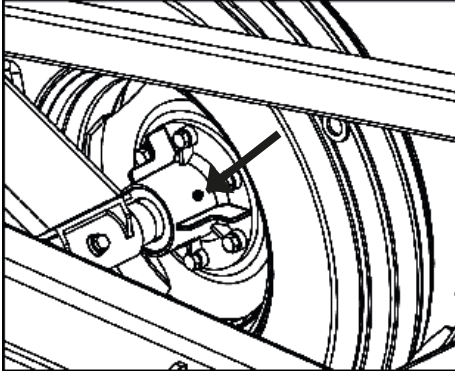

CRSG FROM 18 TO 28 DISCS.

ATTENTION

When lubricating the CRSG, do not exceed the amount of new grease. Introduce an adequate amount.

- Self-lubricating bushings

The **CRSG** has self-lubricating bushings on the stem of the hydraulic cylinder (1) and the hub of the wheel shaft (2). These bushings are not used with any kind of grease or lubricant.

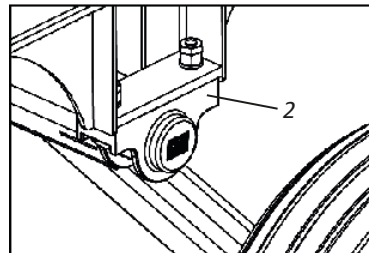
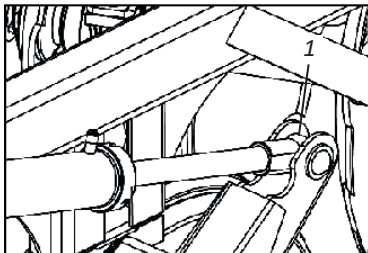

ATTENTION

Only in the initial assembly of the hydraulic cylinder rod (1) and the hub of the wheel shaft (2), grease must be inserted throughout the bushing to avoid oxidation on the rod fixing pin and the wheel shaft.

IMPORTANT

When replacing the self-lubricating bushings of the hydraulic cylinder rod (1) and the wheel fixing hub (2), also insert grease into the entire bushing.

▪ Maintenance

• Oil bearing

On the first days of **CRSG** work, check the oil level of the bearings daily, then check every 120 hours of work.

OBSERVATION

The ideal oil level is when it reaches the plug hole.
To check bearing oil level, search for a flat surface.

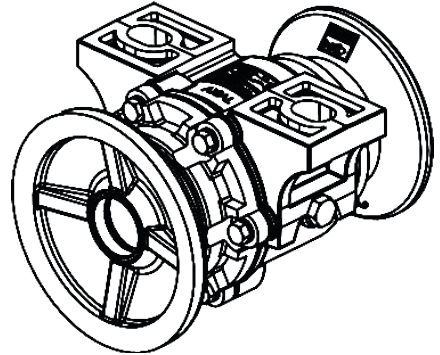

ATTENTION

Change the oil every 1200 hours of work using 0.270 liters.
Use transmission oil: 90 API GL4, MIL-L-2105; SAEJ306, May/81: SAE 80W, 90 and 140.

• Grease bearing

Grease bearings must be lubricated every 12 working hours, using the grease specified below.

OBSERVATION

Before lubricating bearings, wipe grease with a clean, lint-free cloth. Replace damaged grease fittings.

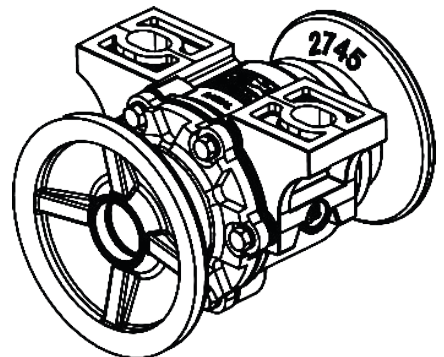

ATTENTION

The amount of grease in each bearing is 300 grams.
Only use the following grease: EP (Specification DIN51825 KP00K Consistency NLGI 2/3).

▪ Maintenance

• Operational maintenance

PROBLEMS	PROBABLE CAUSES	SOLUTIONS
Tires are damaged.	Work area with rocks, stubs or crop remains with stems that shred the tire.	Eliminate elements that damage tires before using the CRSG.
	Improper tire pressure, creating deformations.	Maintain proper tires pressure.
Weird noise on wheels.	Loosen wheels or gap in wheel hub.	Retighten the wheel nuts and adjust wheel hub bearings.
	Breaking of bearings.	Identify the occurrence and females of the same type.
Quick coupling is not fitting.	Couplings of different types.	Change them for males and females of the same type.
Leakage in hydraulic hose.	Lack of sealing material on the thread.	Use sealing tape and retighten carefully.
	Insufficient tightening.	Retighten carefully.
	Damaged repairs.	Replace hubs.
Leakage in quick couplings.	Insufficient tightening.	Retighten carefully without excess.
	Damaged repairs.	Replace hubs.
Quick coupling is not coupling.	Couplings of different brands.	Use a quick coupling of the same brand.
	Mixing of needle-type coupling with sphere-type coupling.	Always use quick coupling of the same type.
	Pressure on the system.	Relief the pressure to couple.

▪ Maintenance

• Cares

- 01** - Before each job, check the condition of all hoses, pins, bolts, bearings, discs and sections. Where necessary, retighten them.
- 02** - The displacement speed should be carefully controlled according to the land's conditions.
- 03** - The **CRSG** is used in several applications, requiring knowledge and attention during handling.
- 04** - Only local conditions can determine the best method of operation of **CRSG**.
- 05** - When assembling or dismantling any part of the **CRSG**, employ appropriate methods and tools.
- 06** - Carefully observe the lubrication intervals in the various lubrication points of the **CRSG**. Respect the lubrication intervals.
- 07** - Always check if the parts have wears. If there is a need for replacement, always demand Baldan original parts.
- 08** - Keep the **CRSG** discs always sharp.



IMPORTANT

Proper and periodic maintenance are necessary to ensure the long life of **CRSG**.

▪ Maintenance

• General cleaning - Part I

- 01** - When storing the **CRSG**, make a general cleaning and wash it thoroughly with water only. Make sure the paint has not worn out, if it did, give a general coat, pass the protective oil and fully lubricate the **CRSG**. Do not use burned oil or other abrasive.
- 02** - Fully lubricate the **CRSG**. Check all moving parts of the **CRSG** for wear and tear, make the necessary adjustment or replacement of the parts, leaving the harrow ready for the next job.
- 03** - After all maintenance work, store the harrow in a covered and dry place, properly supported.

Avoid: - That the discs come into direct contact with the ground.

- The compression of the springs.
- That the hydraulic hoses be properly capped.

▪ Maintenance

• General cleaning - Part II

- 04** - When connecting or disconnecting hydraulic hoses, do not let the terminals touch the ground. Before connecting the hydraulic hoses, wipe the connections with a clean, lint-free cloth. **Do not use tow!**
- 05** - Replace all adhesives, especially those about warnings, that are damaged or missing. Make everyone aware of the importance and risks of accidents when instructions are not followed.
- 06** - After all maintenance care, store your **CRSG** on a flat, covered, dry surface, away from animals and children.
- 07** - We recommend washing the **CRSG** with water only at the start of work.



ATTENTION

Do not use chemicals or abrasives to rinse the **CRSG**, this may damage the paint and adhesives.

• Conservation of the harrow - Part I

To prolong the life and appearance of the **CRSG** for longer, follow the instructions below:

- 01** - Wash and clean all harrow components during and at the end of the work season.
- 02** - Use neutral products to clean the harrow, following the safety and maintenance instructions provided by the manufacturer.
- 03** - Always carry out maintenance during the periods indicated in this manual.

• Conservation of the harrow - Part II

The practices and care below if adopted by the owner or operator make a difference to the conservation of the **CRSG**.

- 01** - Be careful when performing high-pressure washing; do not direct the water jet directly into the connectors and electrical components. Isolate all electrical components;
- 02** - Use only NEUTRAL detergent and water (pH equal to 7);
- 03** - Apply the product, following the manufacturer's instructions strictly, on the wet surface and in the correct sequence, respecting the time of application and washing;
- 04** - Stains and dirt not removed with the products should be removed with the aid of a sponge.
- 05** - Rinse the machine with clean water to remove any chemical residues.

▪ Maintenance

• Conservation of the harrow - Part III

- 06 - Do not use: - Detergents with a basic active ingredient (pH greater than 7), can attack/stain the paint on the harrow.
- **Detergents with acid active ingredient (pH less than 7), act as stripper/remover of zinc coating (the protection of parts against oxidation).**

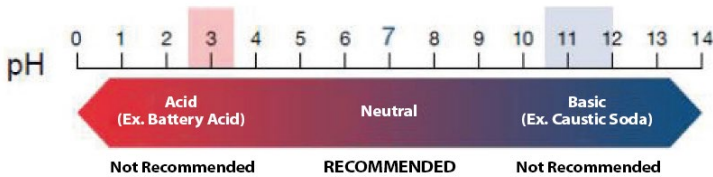

- 07 - Allow the machine to dry in the shade so that it does not accumulate water in its components. Very fast drying can cause stains on your paint.
- 08 - After drying, lubricate all chains and greases according to the recommendations in the operator's manual.
- 09 - Spray all the machine, especially the zinc parts, with protective oil, following the manufacturer's application guidelines. The protective also prevents dirt from adhering to the machine, facilitating subsequent washings.
- 10 - Observe curing (absorption) time and application intervals as recommended by the manufacturer.



ATTENTION

Do not use any other type of oil to protect the harrow (used hydraulic oil, "burnt" oil, diesel oil, castor oil, kerosene, etc.).



IMPORTANT

We recommend the following protective oils:

- Bardahl: Agro protective 200 or 300
- ITWChemical: Zoxol DW - Series 4000



OBSERVATION

Ignoring the conservation measures mentioned above may result in the loss of warranty for painted or zinc-coated components which may exhibit oxidation (rust).

▪ Lifting

• Lifting points

The CRSG has 4 “A” lift points located in the upright and identified through the adhesive (1) attached to these points. When assembling, loading, unloading or servicing the CRSG, if you need to lift with a winch, it is essential to engage the chains in the 4 “A” lifting points.

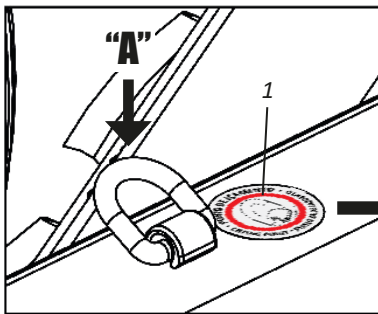
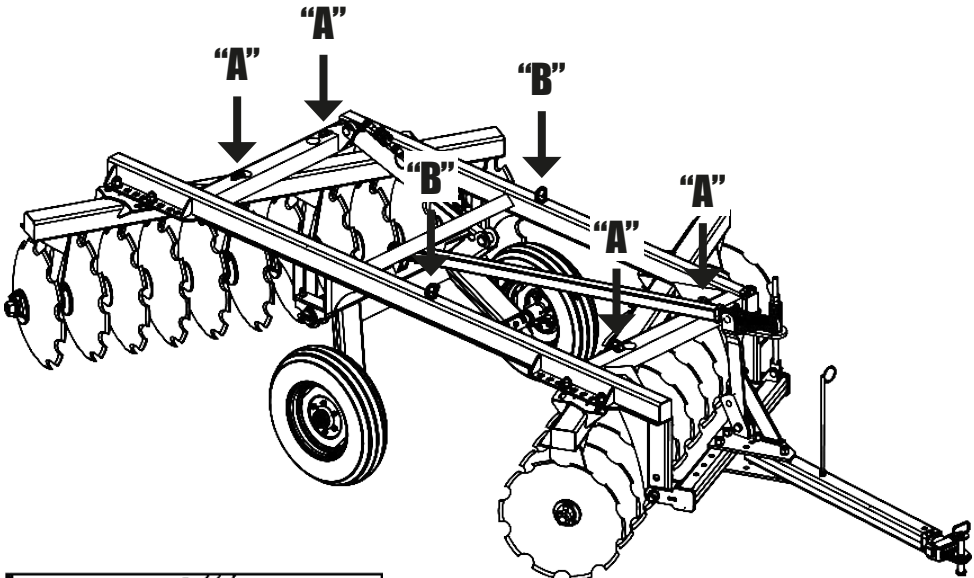

MAXIMUM LOAD: 1000 KG

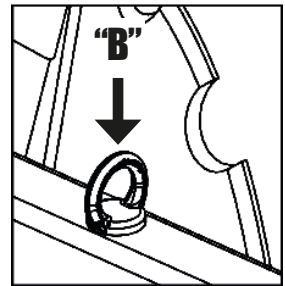

MAXIMUM LOAD: 300 KG

ATTENTION

DO NOT use the 2 “B” points in any way to lift the CRSG. These points are only used during the CRSG manufacturing process. Ignoring this warning may cause severe accidents or death.

▪ Optional**• Optional accessories**

The CRSG has optional accessories that can be acquired according to the need of work.

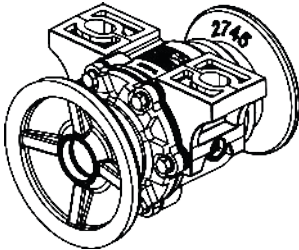
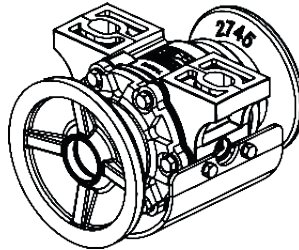
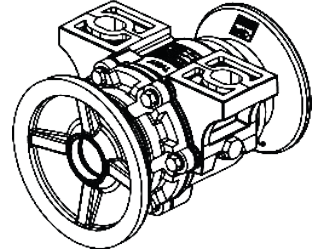
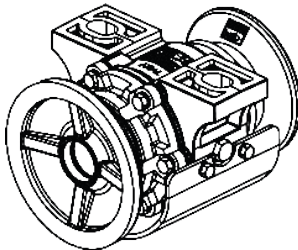
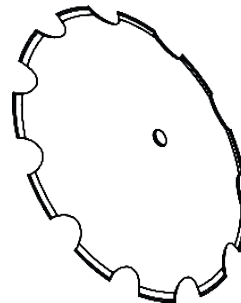
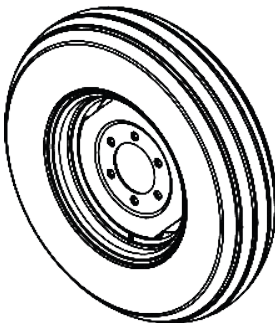
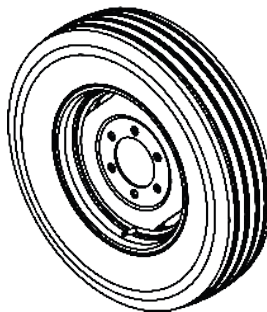
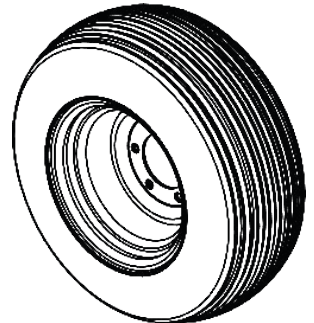
**GREASE BEARING
WITHOUT GUARD****GREASE BEARING
WITH GUARD****AXIAL BEARING
WITHOUT GUARD****AXIAL BEARING
WITH GUARD****DISC TRIMMED
24", 26", 28"****TIRES 750 X 16 10 CANVAS
CRSG 12 TO 16 DISCS****TIRES 650 X 16 8 CANVAS
CRSG 12 TO 16 DISCOS****TIRES 11 X 15 - BL 10 CANVAS
CRSG 18 TO 28 DISCS**

▪ Identification

• Identification plate

To see the parts catalog or to request technical assistance from Baldan, always inform model (01), serial number (02) and date of manufacture (03), which is on your CRSG nameplate.



ATTENTION

The drawings in this Instruction Manual are merely illustrative.

CONTACT

In case of doubts, never operate or handle your equipment without referring to Post-Sales.
 Telephone: 0800-152577
 e-mail: posvenda@baldan.com.br

PUBLICATIONS

Code: 60550108499 | CPT: CRS122804622A



▪ Identification**• Product Identification**

Please make the correct identification of the data below, to always have information about the service life of your equipment.

Owner: _____

Dealer: _____

Property: _____

City: _____

State: _____

Certificate of Warranty no.: _____

Implement: _____

Serial No: _____

Purchase Date: _____

Invoice: _____

BALDAN IMPLEMENTOS AGRÍCOLAS S/A ensures the dealer normal performance of the implement for a period of six (6) months as of the delivery date on the retail invoice to the first final consumer. During this period, **BALDAN** undertakes to repair defects in material and/or of manufacture of its liability, including labor, freight and other expenses of the dealer's liability.

In the warranty period, request and replacement of eventual defective parts shall be made to the dealer of the area, who will submit the faulty piece for **BALDAN** analysis. When this procedure is not possible and the resolving capacity of the dealer is exhausted, the dealer will request the support of **BALDAN Technical Assistance** through a specific form distributed to dealers. After analyzing the replaced items by Baldan Technical Assistance, and concluding that it is not a warranty, then the dealer will be responsible for the costs related to the replacement; as well as material expenses, travel including accommodation and meals, accessories, lubricant used and other expenses arising from the call out to Technical Assistance, and Baldan company is authorized to carry the respective invoice in the name of the resale. Any repair carried in the product within the dealer warranty deadline will only be authorized by **BALDAN** upon previous budget presentation describing parts and work to be performed.

The product is excluded from this term if it is repaired or modified by representatives not belonging to the **BALDAN** dealer network, as well as the application of non-genuine parts or components to the user's product. This warranty is void where it is found that the defect or damage is caused by improper use of the product, failure to follow instructions or inexperience of the operator.

It is agreed that this warranty does not cover tires, polyethylene tanks, cardan, hydraulic components, etc., which are equipment guaranteed by their manufacturers. Manufacturing and/or material defects, object of this warranty term, will not constitute, under any circumstances, grounds for termination of a purchase agreement, or for indemnification of any nature.

BALDAN reserves the right to change and/or perfect the technical characteristics of its products, without previous notice, and without obligation to proceed in the same way with the products previously manufactured.

▪ Inspection and Delivery Certificate

SERVICE BEFORE DELIVERY: This implement was carefully prepared by the sale organization, with all its parts inspected according to the manufacturing prescriptions.

DELIVERY SERVICE: The user was informed about the current warranty terms and instructed on the usage maintenance precautions.

I confirm that the user has been informed about the current warranty terms and instructed on the usage maintenance precautions.

Implement: _____ Serial Number: _____

Date: _____ Tax Number: _____

Dealer: _____

Telephone: _____ CEP: _____

City: _____ State: _____

Owner: _____

Telephone: _____

Address: _____ Number: _____

City: _____ State: _____

E-mail: _____

Sale date: _____

Signature / Dealer Stamp _____

▪ Inspection and Delivery Certificate

SERVICE BEFORE DELIVERY: This implement was carefully prepared by the sale organization, with all its parts inspected according to the manufacturing prescriptions.

DELIVERY SERVICE: The user was informed about the current warranty terms and instructed on the usage maintenance precautions.

I confirm that the user has been informed about the current warranty terms and instructed on the usage maintenance precautions.

Implement: _____ Serial Number: _____

Date: _____ Tax Number: _____

Dealer: _____

Telephone: _____ CEP: _____

City: _____ State: _____

Owner: _____

Telephone: _____

Address: _____ Number: _____

City: _____ State: _____

E-mail: _____

Sale date: _____

Signature / Dealer Stamp _____

▪ Inspection and Delivery Certificate

SERVICE BEFORE DELIVERY: This implement was carefully prepared by the sale organization, with all its parts inspected according to the manufacturing prescriptions.

DELIVERY SERVICE: The user was informed about the current warranty terms and instructed on the usage maintenance precautions.

I confirm that the user has been informed about the current warranty terms and instructed on the usage maintenance precautions.

Implement: _____ Serial Number: _____

Date: _____ Tax Number: _____

Dealer: _____

Telephone: _____ CEP: _____

City: _____ State: _____

Owner: _____

Telephone: _____

Address: _____ Number: _____

City: _____ State: _____

E-mail: _____

Sale date: _____

Signature / Dealer Stamp _____

3rd copy - Manufacturer (Please send completed within 15 days).

1.74.05.0059-5

AC MATÃO
ECT/DR/SP

RESPONSE CARD

NO STAMPING IS REQUIRED

THE STAMP WILL BE PAID BY:



BALDAN IMPLEMENTOS AGRÍCOLAS S/A.

Av. Baldan, 1500 | Nova Matão | CEP: 15993-900 | Matão-SP | Brasil

Tel: (16) 3221-6500 | Fax: (16) 3382-6500

www.baldan.com.br | email: sac@baldan.com.br

Export: Tel: +55 (16) 3221-6500 | Fax: +55 (16) 3382-4212 | 3382-2480

email: export@baldan.com.br



Avenida Baldan, 1500
Nova Matão
15.993-900
Matão/SP - Brasil
sac@baldan.com.br
export@baldan.com.br

+55 16 3221 6500
baldan.com.br